



UNIVERSITÀ
DEGLI STUDI
FIRENZE

FLORE

Repository istituzionale dell'Università degli Studi di Firenze

Hirzebruch surfaces in a one-parameter family

Questa è la Versione finale referata (Post print/Accepted manuscript) della seguente pubblicazione:

Original Citation:

Hirzebruch surfaces in a one-parameter family / Fiammetta Battaglia, Elisa Prato, Dan Zaffran. - In: BOLLETTINO DELLA UNIONE MATEMATICA ITALIANA. - ISSN 1972-6724. - STAMPA. - 12:(2019), pp. 293-305. [10.1007/s40574-018-0181-1]

Availability:

The webpage <https://hdl.handle.net/2158/1126449> of the repository was last updated on 2022-11-01T16:17:45Z

Published version:

DOI: 10.1007/s40574-018-0181-1

Terms of use:

Open Access

La pubblicazione è resa disponibile sotto le norme e i termini della licenza di deposito, secondo quanto stabilito dalla Policy per l'accesso aperto dell'Università degli Studi di Firenze (<https://www.sba.unifi.it/upload/policy-oa-2016-1.pdf>)

Publisher copyright claim:

La data sopra indicata si riferisce all'ultimo aggiornamento della scheda del Repository FloRe - The above-mentioned date refers to the last update of the record in the Institutional Repository FloRe

(Article begins on next page)

HIRZEBRUCH SURFACES IN A ONE-PARAMETER FAMILY

FIAMMETTA BATTAGLIA, ELISA PRATO, DAN ZAFFRAN

ABSTRACT. We introduce a family of spaces, parametrized by positive real numbers, that includes all of the Hirzebruch surfaces. Each space is viewed from two distinct perspectives. First, as a leaf space of a compact, complex, foliated manifold, following [BZ1]. Second, as a symplectic cut of the manifold $\mathbb{C} \times S^2$ in a possibly nonrational direction, following [BP2].

INTRODUCTION

This article is dedicated to the memory of Paolo de Bartolomeis and presents a theme in which complex and symplectic geometry are closely intertwined.

Hirzebruch surfaces were introduced by Hirzebruch in his thesis [H] and turn out in a number of different contexts. They are complex algebraic surfaces, parametrized by positive integers. For each such integer n , the Hirzebruch surface \mathbb{F}_n is the projectivization of the bundle $\mathcal{O} \oplus \mathcal{O}(n)$ over $\mathbb{C}\mathbb{P}^1$. Hirzebruch surfaces are toric manifolds. In fact, for each n , the surface \mathbb{F}_n

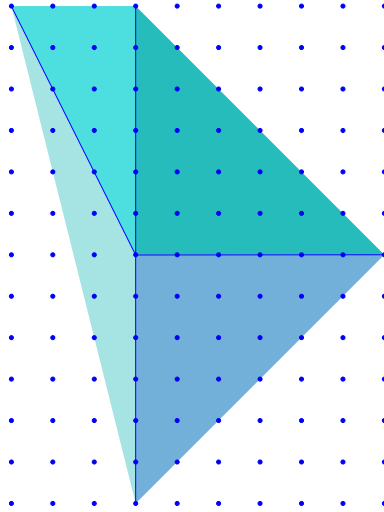
FIGURE 1. The fan Δ_2 .

can be constructed from the fan Δ_n drawn in Figure 1 for $n = 2$; the slanting ray passes through the point $(-1, n)$, while the other three are fixed

(see, for example, [F, Section 1.1]). The fan Δ_n is smooth. In fact, Δ_n is rational, since each of its rays intersects the lattice \mathbb{Z}^2 , and clearly simplicial; moreover, the primitive generators of the two rays of each of its maximal cones form a basis of \mathbb{Z}^2 . The fan Δ_n is also polytopal, i.e. there exists a convex polytope $P_n \subset (\mathbb{R}^2)^*$, given in this case by a right trapezoid, having Δ_n as normal fan. Each ray of Δ_n is the inward-pointing normal ray of a facet of P_n and the maximal cones of Δ_n are in duality with the vertices of P_n (see Figure 2). Since the normal fan to P_n is smooth, the trapezoid P_n is

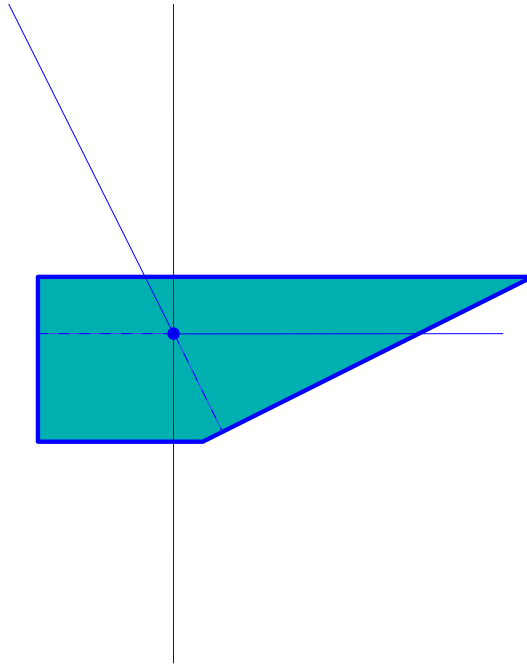

FIGURE 2. The polytope P_2 with its normal fan.

also smooth (see Figure 3). We remark that there are infinitely many such trapezoids P_n . The choice of a particular one defines a Kähler structure on \mathbb{F}_n . One way to see this is to recall that, from each P_n , one obtains a symplectic toric manifold via the Delzant construction [D]; this is equivariantly diffeomorphic to the toric manifold \mathbb{F}_n , and its symplectic structure is compatible with the complex one [A, Chapter VI]. From now on, we will make a choice and call P_n the right trapezoid of vertices $(0, 0)$, $(0, 1)$, $(n + 1, 1)$, and $(1, 0)$.

Classically, the above constructions make sense only for positive integers n . Is there a way to extend the Hirzebruch family, allowing n to be any positive real number a ?

From the convex-geometric viewpoint, for any positive real number a , we still have a simplicial polytopal fan Δ_a , together with the corresponding

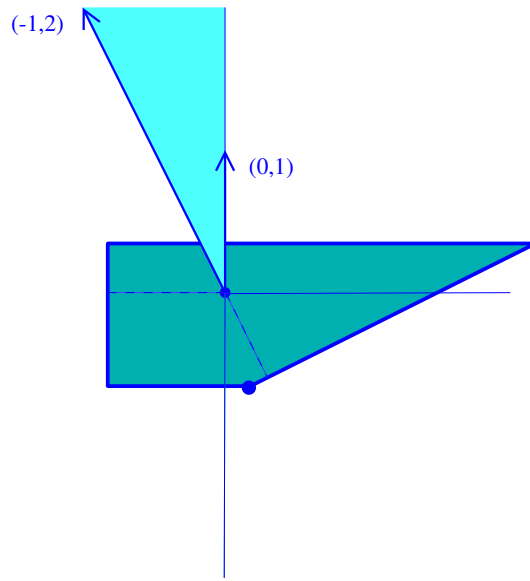

FIGURE 3. A vertex of P_2 and its corresponding maximal cone.

right trapezoid P_a . However, for nonrational values of a , Δ_a , and thus P_a , are not rational in \mathbb{Z}^2 (see Figure 4). According to [P, BP1], we may consider

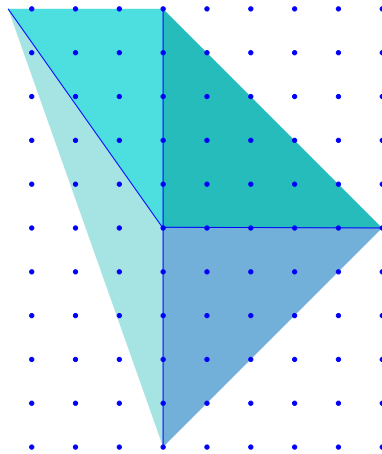

FIGURE 4. The fan $\Delta_{\sqrt{2}}$.

Δ_a and P_a in a nonrational setting and construct, for each positive real number a , a Kähler toric quasifold \mathbb{F}_a (see Section 1). When a is rational, we obtain a Kähler orbifold; when a is an integer n , we recover the Hirzebruch surface \mathbb{F}_n . In this article, we present two alternative constructions of \mathbb{F}_a . All three points of view rely on the idea, introduced in [P], of replacing the

lattice \mathbb{Z}^2 by the quasilattice

$$Q_a = \text{span}_{\mathbb{Z}}\{(1, 0), (0, 1), (0, -1), (-1, a)\} = \mathbb{Z} \times (\mathbb{Z} + a\mathbb{Z}).$$

The first construction, introduced in [BZ1], provides a smooth model for each \mathbb{F}_a . More precisely, for each a , we construct a compact, complex manifold N_a , endowed with a holomorphic, transversely Kähler foliation \mathcal{F}_a , such that the leaf space is exactly \mathbb{F}_a . The general construction builds on previous work by Meersseman–Verjovsky; in particular, the case a positive integer is treated in [MV, Example 5.6]. The manifolds N_a are in the so-called LVM family: a large class of compact, complex, non-Kähler manifolds, introduced by Lopez de Medrano, Verjovsky, and Meersseman in [LV, M]. As shown in [LN, M], they are endowed with a holomorphic foliation. The foliated manifolds (N_a, \mathcal{F}_a) that we obtain are of complex dimension 3, with one-dimensional foliation. The topological type of the generic leaf is

$$\mathcal{F}_{[a]} \simeq \begin{cases} (S^1)^2 & \text{if } a \in \mathbb{Q} \\ S^1 \times \mathbb{R} & \text{if } a \notin \mathbb{Q} \end{cases} ;$$

it varies from closed to nonclosed, depending on whether a is rational or not. When a is irrational, the closure of the generic leaf is diffeomorphic to $(S^1)^3$. This model has a symplectic counterpart, where N_a is seen as a presymplectic foliated manifold [BZ1, BZ2]. Finally, we remark that, for each a , it is possible to construct infinitely many further pairs (N, \mathcal{F}) , where the manifold N can have any dimension greater or equal to 3, and such that the leaf space is \mathbb{F}_a . For a study of these manifolds see [BZ3].

The second construction consists in realizing the quasifold \mathbb{F}_a as a symplectic cut of the manifold $\mathbb{C} \times S^2$. The idea is that the trapezoid P_a can be obtained by cutting the strip $[0, +\infty) \times [0, 1]$ with the line $x = ay + 1$ (see Figure 5), where the strip indeed corresponds to the symplectic toric manifold $\mathbb{C} \times S^2$. However, for nonrational values of a , this line is irra-

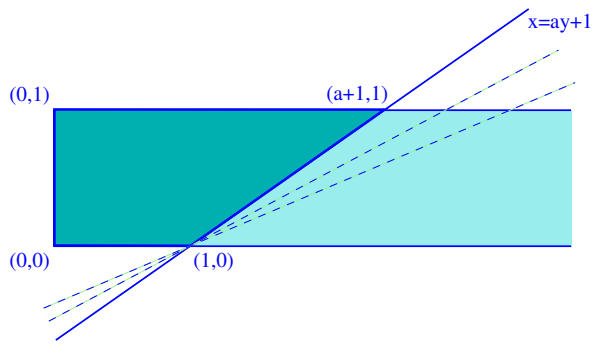

FIGURE 5. Cutting $\mathbb{C} \times S^2$ in arbitrary directions.

tionally sloped and the classical Lerman cut [L] cannot be applied. We rely

on a generalization of this procedure that allows cutting in an arbitrary direction [BP2]. One of the relevant features of this point of view is that it allows to express the symplectic quasifold \mathbb{F}_a as a disjoint union of a compact two-dimensional quasifold and of an open dense subset. The first is given by S^2/Γ_a , where the countable group $\Gamma_a = Q_a/\mathbb{Z}^2$ acts on S^2 by rotations, around the z -axis, of integer multiples of $2\pi a$; the second is an open subset of $\mathbb{C} \times S^2$, again modulo the above action of Γ_a on S^2 .

As we have seen, the topological structure of \mathbb{F}_a varies depending on the rationality of a . Notice that, within the family \mathbb{F}_a , we can pass from one Hirzebruch surface to the other; however, this is not done via a deformation, in accordance with the fact that Hirzebruch surfaces \mathbb{F}_n have two distinct diffeomorphism types, depending on the parity of n [H].

1. PRELIMINARIES

We recall the basic facts on toric geometry for nonrational convex polytopes, following [P, BP1], and we apply them to the generalized Hirzebruch setting. Section 1.1 is an outline of some relevant notions in convex geometry. In Section 1.2, we recall what *toric quasifolds* are and we describe the generalized Hirzebruch quasifold \mathbb{F}_a .

1.1. Convex polytopes, fans, and quasilattices. A convex polytope $P \subset (\mathbb{R}^k)^*$ determines a fan $\Delta \subset \mathbb{R}^k$, known as the *normal fan* to P . There is an inclusion-reversing bijection between cones in Δ and faces of P . For example, each of the *rays*, namely the one-dimensional cones, of Δ is orthogonal to a facet of P and points towards its interior. The maximal cones of Δ , on the other hand, correspond to the vertices of P . For more on convex polytopes and their normal fans, we refer the reader to [Z]. We just recall a few more relevant facts. The convex polytope P is said to be *simple* if its normal fan is *simplicial*, namely if each cone of Δ is a cone over a simplex. Therefore, a k -dimensional convex polytope P is simple if, and only if, each of its vertices is the intersection of exactly k facets. The convex polytope P is said to be *rational* if its normal fan is, namely if there is a lattice $L \subset \mathbb{R}^k$ that has nonempty intersection with each of the rays of Δ . Finally, the convex polytope P is said to be *smooth* if its normal fan is, namely if Δ is rational, simplicial and, for each of the maximal cones of Δ , the primitive generators of its rays form a basis of the lattice. The toric variety corresponding to a smooth fan is also smooth. The lattice and the set of primitive (or minimal) generators of the rays of any rational fan are key ingredients in the construction of the corresponding toric variety (see, for example, [A, Chapter 6] or [CLS]). What happens for nonrational fans? The idea, introduced by the second author in [P], is to replace the lattice with a *quasilattice* $Q \subset \mathbb{R}^k$, namely the \mathbb{Z} -span of a set of \mathbb{R} -spanning vectors of \mathbb{R}^k . One way of constructing a quasilattice in this setting is to choose a set of generators of the rays of the fan and to let Q be equal to their \mathbb{Z} -span. There is of course a lot of freedom in the choice of the generators in general, but in some cases one

can be guided by the underlying geometric setup. This is exactly what happens in the Hirzebruch setting. The set of primitive generators for the rays of the Hirzebruch fan Δ_n is given by $\{(1, 0), (0, 1), (0, -1), (-1, n)\}$. Therefore, if we allow n to be any positive real number a , the natural choice for a set of generators for the rays of the fan Δ_a is $\{(1, 0), (0, 1), (0, -1), (-1, a)\}$. This yields the quasilattice

$$Q_a = \text{span}_{\mathbb{Z}}\{(1, 0), (0, 1), (-1, a)\} = \mathbb{Z} \times (\mathbb{Z} + a\mathbb{Z}) \supseteq \mathbb{Z}^2.$$

Notice that, for a rational, Q_a is a lattice; for a natural this lattice equals \mathbb{Z}^2 .

1.2. Toric quasifolds. Toric quasifolds are the natural generalization of toric manifolds in the nonrational setting. Quasifolds were introduced by the second author in [P]. They are singular spaces that generalize manifolds and orbifolds. They are locally modeled by quotients of manifolds modulo the smooth action of countable groups and they are typically not Hausdorff. Notable examples of quasifolds are the so-called *quasitori* $D^k = \mathbb{R}^k/Q$, Q being a quasilattice in \mathbb{R}^k , and its complexification $D_{\mathbb{C}}^k = \mathbb{C}^k/Q$.

We now recall the extensions to the nonrational setting of the Delzant construction [D] and of its complex counterpart [A]. Let $P \subset (\mathbb{R}^k)^*$ be a simple, dimension k convex polytope, let $\{X_1, \dots, X_d\}$ be a set of generators of the rays of its normal fan and let Q be a quasilattice that contains them. According to [P, Theorem 3.3], for each triple $(P, \{X_1, \dots, X_d\}, Q)$ one can construct a symplectic, dimension $2k$ quasifold M_P that is endowed with an effective Hamiltonian action of the quasitorus D^k ; this action is Hamiltonian and the image of the corresponding moment mapping is the polytope P . On the other hand, by [BP1, Theorem 2.2], for the same triple one can also construct a complex, dimension k quasifold X_P that is endowed with a holomorphic action of the complex quasitorus $D_{\mathbb{C}}^k$; this action has a dense open orbit. Finally, by [BP1, Theorem 3.2], M_P and X_P are equivariantly diffeomorphic and the induced symplectic form on X_P is Kähler. The spaces M_P and X_P are respectively called the *symplectic* and *complex toric quasifold* corresponding to the triple $(P, \{X_1, \dots, X_d\}, Q)$.

Let us now consider, for any positive real number a , the generalized Hirzebruch trapezoid P_a ; its vertices are given by $(0, 0)$, $(0, 1)$, $(a + 1, 1)$, and $(1, 0)$ (see Figure 6). Take the countable group

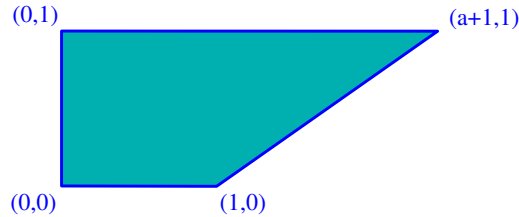

FIGURE 6. The trapezoid P_a .

$$\Gamma_a = Q_a/\mathbb{Z}^2 \simeq (\mathbb{Z} + a\mathbb{Z})/\mathbb{Z}.$$

One can verify that, for the triple

$$\left(P_a, \{(1, 0), (0, 1), (0, -1), (-1, a)\}, Q_a \right),$$

the results above yield the symplectic toric quasifold

$$\frac{\{z \in \mathbb{C}^4 \mid |z_1|^2 + a|z_3|^2 + |z_4|^2 = 1 + a, |z_2|^2 + |z_3|^2 = 1\}}{\{(e^{2\pi ir}, e^{2\pi is}, e^{2\pi i(s+ar)}, e^{2\pi ir}) \in \mathbb{R}^4/\mathbb{Z}^4 \mid r, s \in \mathbb{R}\}},$$

acted on by the quasitorus $D_a^2 = \mathbb{R}^2/Q_a \simeq S^1 \times (S^1/\Gamma_a)$, and the complex toric quasifold

$$\frac{\{z \mid z_3 z_4 \neq 0\} \cup \{z \mid z_1 z_3 \neq 0\} \cup \{z \mid z_1 z_2 \neq 0\} \cup \{z \mid z_2 z_4 \neq 0\}}{\{(e^{2\pi iu}, e^{2\pi iv}, e^{2\pi i(v+au)}, e^{2\pi iu}) \in \mathbb{C}^4/\mathbb{Z}^4 \mid u, v \in \mathbb{C}\}},$$

acted on by the complex quasitorus $(D_a^2)_{\mathbb{C}} = \mathbb{C}^2/Q_a \simeq \mathbb{C}^* \times (\mathbb{C}^*/\Gamma_a)$. We denote \mathbb{F}_a the resulting Kähler toric quasifold. If a is a rational number that is not an integer, we can write $a = \frac{p}{q}$, with p, q coprime positive integers and $q > 1$. In this case, \mathbb{F}_a is a topologically smooth Kähler toric orbifold with two disjoint singular divisors of order q given by $z_2 = 0$ and $z_3 = 0$, which correspond to the bases of the trapezoid P_a . Notice finally that, for a equal to a positive integer n , we obtain the standard Hirzebruch surface \mathbb{F}_n .

2. FOLIATIONS MODELING \mathbb{F}_a

In this section, we apply a construction developed in [BZ1] that allows to model complex and symplectic quasifolds by complex and presymplectic, foliated, smooth manifolds, respectively. This viewpoint builds on the articles [P] and [MV]. In Section 2.1, convex data are interpreted in the context of vector configurations. In Section 2.2, we review the complex construction focussing on the Hirzebruch family and finally, in Section 2.3, we illustrate the symplectic side of the picture, for which we refer also to [BZ2].

2.1. Vector and point configurations. Consider a complete simplicial fan $\Delta \subset \mathbb{R}^k$; complete means that the union of its cones is \mathbb{R}^k . Let $\{X_1, \dots, X_d\}$ be a choice of generators of the rays of Δ and let Q be a quasilattice containing them. Each triple $(\Delta, \{X_1, \dots, X_d\}, Q)$ can be encoded in a well-studied convex object, a *triangulated vector configuration* [BZ1, Section 2.1]. In the Hirzebruch case, the triple $(\Delta_n, \{(1, 0), (0, 1), (0, -1), (-1, n)\}, Q_n)$ can be encoded in (V'_n, \mathcal{T}) , where $V'_n = ((1, 0), (0, 1), (0, -1), (-1, n))$ and $\mathcal{T} = \{\{1, 2\}, \{2, 4\}, \{3, 4\}, \{1, 3\}, \{1\}, \{2\}, \{3\}, \{4\}, \emptyset\}$. The set of vectors V'_n is a *vector configuration*: a finite, ordered list of vectors, allowing repetitions. The vector configuration V'_n contains the following information: a set of ray generators, and therefore the rays themselves, and the lattice $\text{span}_{\mathbb{Z}}\{V'_n\} = \mathbb{Z}^2$. The set \mathcal{T} is a *triangulation* of V'_n . It is a collection of subsets of $\{1, 2, 3, 4\}$, with suitable properties. In this case, \mathcal{T} carries the

combinatorial information of Δ_n : for example, $\{1, 2\}$ corresponds to the maximal cone in Δ_n generated by the first and second vectors of V'_n . By convention, the cone corresponding to \emptyset is $\{0\}$.

In general, for our construction, we will need a vector configuration that is *balanced*, meaning that the sum of its vectors is 0, and *odd*, meaning that $\text{card}(V'_n) - \dim(\text{span}_{\mathbb{R}}(V'_n))$ is odd. We can ensure that these two assumptions are verified by adding to our configuration, if necessary, some extra vectors, known as *ghost vectors*. For the Hirzebruch fan we can take

$$V_n = \left((1, 0), (0, 1), (0, -1), (-1, n), (0, -n) \right).$$

The fifth vector $(0, -n)$ is a ghost vector since is not indicized by any subset of \mathcal{T} . Now $\text{card}(V_n) - \dim(\text{span}_{\mathbb{R}}(V_n)) = 5 - 2 = 3 = 2m + 1$, with $m = 1$. Remark that the configuration V_n is not uniquely determined. For example, we could append to V_n any even number of ghost vectors in \mathbb{Z}^2 . This operation is sometimes necessary in order to ensure that the \mathbb{Z} -span of the vector configuration is the given lattice or quasilattice.

We consider, as initial convex datum, (V_n, \mathcal{T}) , with n positive integer. Its natural generalization to positive real numbers a is the triangulated vector configuration (V_a, \mathcal{T}) , with $V_a = ((1, 0), (0, 1), (0, -1), (-1, a), (0, -a))$. Now apply *Gale duality*: choose a basis of the relations $\text{Rel}(V_a) \subset \mathbb{R}^5$ of V_a and write it as rows in a matrix:

$$\begin{pmatrix} 1 & 1 & 1 & 1 & 1 \\ 0 & 1 & 1 & 0 & 0 \\ 1 & 0 & a & 1 & 0 \end{pmatrix}.$$

Ignoring the first row, we interpret each column as the real and imaginary parts of a complex number. This yields the *configuration of points* (that is a finite ordered list) $\Lambda = (i, 1, 1 + ia, i, 0)$ in affine space $\mathbb{C}^m = \mathbb{C}$, as shown in Figure 7. The corresponding combinatorial datum is a *virtual chamber* \mathcal{T}^* ,

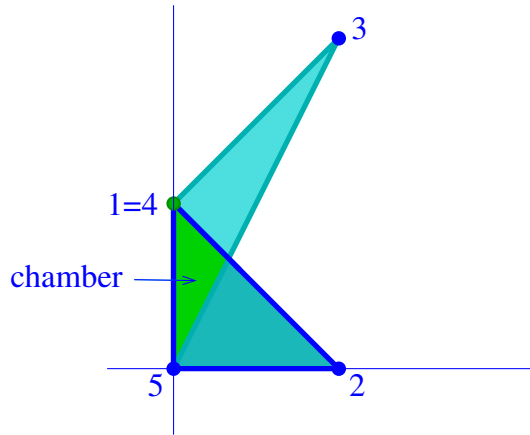

FIGURE 7. Point configuration and chamber.

namely a collection of subsets of $\{1, 2, 3, 4, 5\}$ satisfying certain properties. In our case, we obtain:

$$\mathcal{T}^* = \{\{3, 4, 5\}, \{1, 3, 5\}, \{1, 2, 5\}, \{2, 4, 5\}\}.$$

In fact, the intersection of the four triangles determined by \mathcal{T}^* is nonempty. This happens if, and only if, the fan is polytopal [S].

As we have seen, there are infinitely many triangulated vector configurations encoding a given triple. Moreover, given (V, \mathcal{T}^*) , its Gale dual Λ is not unique, rather it is determined up to a real affine automorphism of \mathbb{C} (see [BZ1, Section 2.2.2] and also [BZ2, Section 1.2] for details). For an exhaustive treatment of notions like vector and point configurations, Gale duality, triangulations, and chambers, we refer the reader to [DRS].

2.2. The complex foliated manifolds (N_a, \mathcal{F}_a) . We consider the LVM datum (Λ, \mathcal{T}^*) . The chamber \mathcal{T}^* determines the open subset $U(\mathcal{T}^*)$ of $\mathbb{C}\mathbb{P}^4$ given by the projectivization of the open subset of \mathbb{C}^5 given by:

$$\{\underline{z} \mid z_3 z_4 z_5 \neq 0\} \cup \{\underline{z} \mid z_1 z_3 z_5 \neq 0\} \cup \{\underline{z} \mid z_1 z_2 z_5 \neq 0\} \cup \{\underline{z} \mid z_2 z_4 z_5 \neq 0\}.$$

The configuration Λ determines the following \mathbb{C}_Λ -action on $U(\mathcal{T}^*)$:

$$\begin{aligned} \mathbb{C}_\Lambda \times U(\mathcal{T}^*) &\longrightarrow U(\mathcal{T}^*) \\ (t, [z_1 : z_2 : z_3 : z_4 : z_5]) &\longmapsto [e^{-2\pi t} z_1 : e^{2\pi i t} z_2 : e^{2\pi i(1+ia)t} z_3 : e^{-2\pi t} z_4 : z_5]. \end{aligned}$$

The quotient $N_a = U(\mathcal{T}^*)/\mathbb{C}_\Lambda$ is a compact, complex manifold [BZ1, Section 2.2.4]. Remark that the above procedure applies to nonpolytopal fans as well [BZ1], yielding a generalized LVM manifold [B]. Following [U], consider now the conjugate point configuration, $\bar{\Lambda}$, of Λ . The action of $\mathbb{C}_{\bar{\Lambda}}$ on $U(\mathcal{T}^*)$ commutes with that of \mathbb{C}_Λ ; therefore, there is an induced action on N_a :

$$\begin{aligned} \mathbb{C}_{\bar{\Lambda}} \times N_a &\longrightarrow N_a \\ (t, [z_1 : z_2 : z_3 : z_4 : z_5]) &\longmapsto [e^{2\pi t} z_1 : e^{2\pi i t} z_2 : e^{2\pi i(1-ia)t} z_3 : e^{2\pi t} z_4 : z_5]. \end{aligned}$$

Its orbits give rise to a holomorphic foliation \mathcal{F}_a in N_a [BZ1, Section 2.3]. The set of generic points in N_a is the dense, open orbit of the induced action of $(\mathbb{C}^*)^4$ on N_a . Moreover, $\mathbb{C}_{\bar{\Lambda}}$ acts on N_a as a subgroup of $(S^1)^4 \subset (\mathbb{C}^*)^4$. This implies that the foliation \mathcal{F}_a is Riemannian [BZ1, Section 2.3.2].

The topological type of the generic leaf and of its closure depends on the measure of the rationality of V [BZ1, Section 2.1.1]. At a generic point $[\underline{z}] \in N_a$, we obtain:

$$\begin{aligned} \mathcal{F}_{[\underline{z}]} &\simeq \begin{cases} (S^1)^2 & \text{if } a \in \mathbb{Q} \\ S^1 \times \mathbb{R} & \text{if } a \notin \mathbb{Q} \end{cases} \\ \bar{\mathcal{F}}_{[\underline{z}]} &\simeq \begin{cases} (S^1)^2 & \text{if } a \in \mathbb{Q} \\ (S^1)^3 & \text{if } a \notin \mathbb{Q}. \end{cases} \end{aligned}$$

This shows very clearly how differently leaves behave when a passes from rational to irrational numbers. This, of course, reflects on the topology of

the leaf space \mathbb{F}_a . In our case, the holomorphic projection from (N_a, \mathcal{F}) to the complex leaf space \mathbb{F}_a has a very simple expression:

$$\begin{array}{ccc} N_a & \longrightarrow & \mathbb{F}_a \\ [z_1 : z_2 : z_3 : z_4 : z_5] & \longmapsto & [z_1 z_5^{-1} : z_2 z_5^{-1} : z_3 z_5^{-1} : z_4 z_5^{-1}]. \end{array}$$

We recall that the complex structure of the leaf space does not depend on the choice of Gale dual. More generally, we have seen that there are infinitely many triangulated vector configurations (V, \mathcal{T}) encoding the triple

$$\left(\Delta_a, \{(1, 0), (0, 1), (0, -1), (-1, a)\}, Q_a \right).$$

For each of them, there are infinitely many choices of Gale dual point configurations (Λ, \mathcal{T}^*) . Thus, we obtain infinitely many foliated manifolds, but only one complex leaf space [BZ2, Theorem 2.1]:

$$\begin{array}{ccc} (V, \mathcal{T}) & \overset{\leftarrow}{\dashrightarrow} & (\Lambda, \mathcal{T}^*) \longrightarrow N/\mathcal{F} \\ \uparrow \downarrow & & \downarrow \\ (\Delta_a, \{(1, 0), (0, 1), (0, -1), (-1, a)\}, Q_a) & \longrightarrow & \mathbb{F}_a \end{array}$$

Dashed arrows here represent directions in which we make choices. On the other hand, the complex structure of the leaves does vary upon the choice of Gale dual. If a is irrational, the leaf $\mathcal{F}_{[\underline{z}]}$ is \mathbb{C}^* for $z_2 z_3 \neq 0$; it is a compact complex torus otherwise. If a equals $\frac{p}{q}$, with p, q coprime positive integers,

$$\mathcal{F}_{[\underline{z}]} = \begin{cases} \mathbb{C}/(\mathbb{Z} \oplus iq\mathbb{Z}) & \text{for } z_2 z_3 \neq 0 \\ \mathbb{C}/\mathbb{Z} \oplus i\mathbb{Z} & \text{for } z_2 = 0 \text{ or } z_3 = 0. \end{cases}$$

By varying our choice of Gale dual, we obtain all possible two-dimensional compact complex tori, in accordance with [MV, Theorem G]. Finally, the generic leaf is a q -sheeted cover of the leaf $\mathcal{F}_{[\underline{z}]}$ through $[\underline{z}] = [z_1 : 0 : z_2 : z_3 : z_4 : z_5]$: when approaching the point $[\underline{z}]$, the generic leaf winds q times around the leaf $\mathcal{F}_{[\underline{z}]}$, compatibly with [MV, Corollary B]. According to [KLMV], the leaf space \mathbb{F}_a , obtained from a nonrational LVM datum (Λ, \mathcal{T}^*) , can be seen from the viewpoint of noncommutative geometry.

2.3. The presymplectic foliated manifolds. Let $(\Delta, \{X_1, \dots, X_d\}, Q)$ be a triple such that Δ is the normal fan of a simple, convex polytope P . Let (V, \mathcal{T}) be a triangulated vector configuration encoding the given triple. The resulting foliated manifold (N, \mathcal{F}) can be viewed in a symplectic setting, by applying a simple variant of the generalized Delzant construction [P, Theorem 3.3] introduced in [BZ2, Proposition 4.3]. Focussing on our Hirzebruch family, consider the triple $(P_a, \{(1, 0), (0, 1), (0, -1), (-1, a)\}, Q_a)$, with the additional datum of the half-plane $-ay \geq -2a$. We then obtain the connected subgroup of $(S^1)^5$ given by $\exp(\text{Rel}(V_a))$; its induced action on \mathbb{C}^5 is Hamiltonian, with moment mapping

$$\Psi_a(\underline{z}) = \left(|\underline{z}|^2 - 2(a+1), |z_1|^2 + a|z_3|^2 + |z_4|^2 - 1 + a, |z_2|^2 + |z_3|^2 - 1 \right).$$

We find the following diagram:

$$\begin{array}{ccc}
 \Psi_a^{-1}(0) & \xrightarrow{S^1} & \Psi_a^{-1}(0)/S^1 & \simeq & N_a \\
 & & \mathbb{R}^2 \downarrow & & \downarrow \mathbb{C}_{\bar{\lambda}_a} \\
 & & (\mathbb{F}_a, \omega) & \simeq & \mathbb{F}_a
 \end{array}$$

where S^1 acts diagonally on \mathbb{C}^5 and the \mathbb{R}^2 -action on $\Psi_a^{-1}(0)/S^1$ is given by:

$$(r, s) \cdot [z] = [e^{2\pi ir} z_1 : e^{2\pi is} z_2 : e^{2\pi i(s+ar)} z_3 : e^{2\pi ir} z_4 : z_5].$$

The manifolds $\Psi_a^{-1}(0)$ and $\Psi_a^{-1}(0)/S^1$ are both presymplectic. The action of \mathbb{R}^2 on $\Psi^{-1}(0)/S^1$ is Hamiltonian and induces a foliation which is sent diffeomorphically to \mathcal{F}_a [BZ2, Section 4]. The presymplectic structure of $\Psi_a^{-1}(0)/S^1$ defines a transversely Kähler structure on (N_a, \mathcal{F}) , a well known result [M, Theorem 7]. This presymplectic viewpoint was already investigated, and key, in [MV], in the rational setting. It is also related to recent articles by Lin–Sjamaar [LS] and Nguyen–Ratiu [NR]. In particular, in the former, symplectic quasifolds are also viewed as leaf spaces of presymplectic manifolds.

3. ARBITRARY TORIC CUTS OF $\mathbb{C} \times S^2$

It is well known that the Hirzebruch surface \mathbb{F}_n can be obtained from weighted projective space $\mathbb{C}\mathbb{P}_{(1,n,1)}^2$ by blowing up its only singular point. In the symplectic category, this can be done by means of the symplectic blowing-up procedure. From the viewpoint of symplectic toric geometry, $\mathbb{C}\mathbb{P}_{(1,n,1)}^2$ corresponds to the triangle T_n of vertices $(0, -1/n)$, $(0, 1)$, and $(n+1, 1)$, with the singular point mapping to the first vertex. As it turns

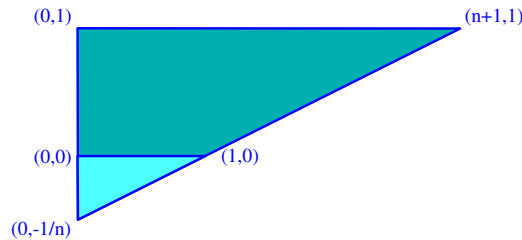

FIGURE 8. Blowing-up $\mathbb{C}\mathbb{P}_{(1,n,1)}^2$.

out, blowing-up this point of the amount $\frac{1}{n}$ corresponds to cutting off a corner of the triangle around the vertex, as in Figure 8 (see, for example, [Gu, Theorem 1.12, Example 1.22]). The resulting convex polytope is the trapezoid P_n , which, as we know, corresponds to \mathbb{F}_n . For an interesting application of this viewpoint, see [Ga].

Here we want to suggest an alternative approach to obtaining \mathbb{F}_n , using the symplectic cutting procedure. This operation was introduced by Lerman [L], and is an important generalization of the symplectic blowing-up operation. In the case of symplectic toric manifolds, the cutting procedure amounts to cutting the moment polytope with a hyperplane, and to considering the toric manifolds corresponding to the two cut polytopes – this will only work if the latter are smooth. The basic idea in the Hirzebruch setting is that one can obtain the trapezoid P_n by cutting the strip $[0, +\infty) \times [0, 1]$ with the line $x = ny + 1$, as in Figure 9. The set $[0, +\infty) \times [0, 1]$ is not a polytope, however it is a pointed polyhedron, and the Delzant construction can still be applied [BP2, Theorem 1.1]. In fact, from the symplectic viewpoint, $[0, +\infty) \times [0, 1]$ corresponds to the noncompact toric manifold $\mathbb{C} \times S^2$ with its standard symplectic structure and torus action.

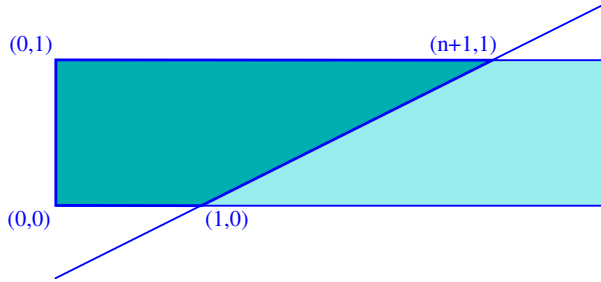

FIGURE 9. Cutting $\mathbb{C} \times S^2$.

Now, what happens if we replace n with any positive real number a ? In order to obtain the trapezoid P_a , we would need to cut the strip $[0, +\infty) \times [0, 1]$ with the line $x = ay + 1$ (see Figure 5). However, for a irrational, the standard cutting procedure does not allow this. We apply a generalization of this operation to symplectic toric quasifolds [BP2], which allows, in particular, to also make sense of cutting any symplectic toric manifold in an arbitrary direction. The main reason why we cannot cut our strip with the irrationally sloped line $x = ay + 1$ is that the line does not have a normal vector sitting in \mathbb{Z}^2 . So the idea is to add this vector and to replace the lattice \mathbb{Z}^2 with the quasilattice

$$\text{span}_{\mathbb{Z}}\{\mathbb{Z}^2 \cup \{(-1, a)\}\}.$$

Notice that this equals once more the quasilattice $Q_a = \mathbb{Z} \times (\mathbb{Z} + a\mathbb{Z})$. Following [BP2, Section 5], in order to cut the manifold $\mathbb{C} \times S^2$, we first need to consider the symplectic toric quasifold corresponding to the triple

$$\left([0, \infty) \times [0, 1], \{(1, 0), (0, 1), (0, -1)\}, Q_a\right).$$

One can verify directly, or deduce from [BP2, Proposition 1.2], that this is given by the quasifold $\mathbb{C} \times (S^2/\Gamma_a)$, where $\Gamma_a = Q_a/\mathbb{Z}^2 \simeq \{e^{2\pi ial} \mid l \in \mathbb{Z}\}$

is acting on $S^2 = \{(v, z) \in \mathbb{C} \times \mathbb{R} \mid |v|^2 + z^2 = 1\}$ by rotations around the z -axis. The quasitorus acting on $\mathbb{C} \times (S^2/\Gamma_a)$ is the same $D_a^2 \simeq S^1 \times (S^1/\Gamma_a)$ of Section 1.2. We then apply the generalized cutting procedure of [BP2, Section 2], which in this case yields the following. First, we consider the Hamiltonian action of S^1 on $\mathbb{C} \times (S^2/\Gamma_a)$ given by $e^{2\pi it} \cdot (u, [v : z]) = (e^{-2\pi it}u, [e^{2\pi iat}v : z])$. One verifies that its moment map is

$$\Phi_Y(u, [v : z]) = -|u|^2 + \frac{a(z+1)}{2}.$$

Then we let S^1 act on $\mathbb{C} \times (S^2/\Gamma_a) \times \mathbb{C}$ with weight -1 on the last component; the corresponding moment mapping is given by

$$\nu_-(u, [v : z], w) = -|u|^2 + \frac{a(z+1)}{2} - |w|^2.$$

The cut space corresponding to the trapezoid is then given by the quotient $\nu_-^{-1}(-1)/S^1$. By [BP2, Theorem 2.3], it coincides with the symplectic toric quasifold \mathbb{F}_a . Moreover, by [BP2, Remark 2.4], this cut can be written, as in the classical cutting procedure, as the disjoint union of the quotient $\Phi_Y^{-1}(-1)/S^1$ and of the open dense subset

$$\begin{aligned} & \{ (u, [v : z]) \in \mathbb{C} \times (S^2/\Gamma_a) \mid \Phi_Y(u, [v : z]) > -1 \} = \\ & \{ (u, [v : z]) \in \mathbb{C} \times (S^2/\Gamma_a) \mid |u|^2 - \frac{a(z+1)}{2} < 1 \}. \end{aligned}$$

We remark that the former is given by S^2/Γ_a (see [BP3, Example 3.2]), while the latter equals the open subset of $\mathbb{C} \times S^2$ given by

$$\{ (u, v, z) \in \mathbb{C} \times S^2 \mid |u|^2 - \frac{a(z+1)}{2} < 1 \},$$

modulo the action of Γ_a . It is indeed a general fact (see [BP2, Proposition 2.5]) that a dense, open subset of the cut space is symplectomorphic to an open subset of the initial manifold, modulo the action of the countable group given by the quotient of the quasilattice by the initial lattice. If a is again equal to $\frac{p}{q}$, with p, q coprime positive integers and $q > 1$, the group Γ_a equals $\mathbb{Z}/q\mathbb{Z}$. It is interesting to notice that the orbifold \mathbb{F}_a inherits its order q singular sets from the orbifold $\mathbb{C} \times (S^2/(\mathbb{Z}/q\mathbb{Z}))$.

We conclude by remarking that \mathbb{F}_a can also be obtained as follows. First we consider the toric quasifold corresponding to the triple

$$\left(T_a, \{(1, 0), (0, -1), (-1, a)\}, Q_a \right),$$

where T_a is the triangle of vertices $(0, -1/a)$, $(0, 1)$ and $(a+1, 1)$. Then, following [BP2, Section 4], we blow-up the point mapping to the first vertex of an amount $\frac{1}{a}$ (see Figure 10). For a equal to a positive integer n , this corresponds to obtaining the Hirzebruch surface by blowing-up weighted projective space, as explained at the beginning of this section.

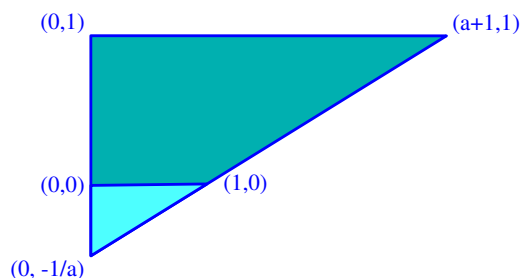
FIGURE 10. Obtaining \mathbb{F}_a via blowing-up.

ACKNOWLEDGEMENTS

The research of the first two authors was partially supported by grant PRIN 2015A35N9B_013 (MIUR, Italy) and by GNSAGA (INdAM, Italy).

REFERENCES

- [A] M. Audin, The topology of torus actions on symplectic manifolds. *Progress in Mathematics* **93**, Birkhäuser, 1991.
- [BP1] F. Battaglia, E. Prato, Generalized toric varieties for simple nonrational convex polytopes, *Int. Math. Res. Not.* **24** (2001), 1315–1337.
- [BP2] F. Battaglia, E. Prato, Nonrational symplectic toric cuts, *Internat. J. Math.* **29** (2018), 1850063, 19 pages.
- [BP3] F. Battaglia, E. Prato, Nonrational symplectic toric reduction, *J. Geom. Phys.* (2018), 10.1016/j.geomphys.2018.09.007.
- [BZ1] F. Battaglia, D. Zaffran, Foliations modeling nonrational simplicial toric varieties, *Int. Math. Res. Not.* **2015**, 11785–11815.
- [BZ2] F. Battaglia, D. Zaffran, Simplicial Toric Varieties as Leaf Spaces, in “Special metrics and group actions in geometry”, S. Chiossi, A. Fino, E. Musso, F. Podestà, L. Vezzoni (eds), Springer INdAM Series **23**, 2017, 21 pages.
- [BZ3] F. Battaglia, D. Zaffran, LVMB manifolds as equivariant group compactifications, in preparation.
- [B] F. Bosio, Variétés complexes compactes: une généralisation de la construction de Meersseman et de López de Medrano–Verjovsky, *Ann. Inst. Fourier* **51** (2001), 1259–1297.
- [CLS] D. Cox, J. Little, H. Schenck, Toric varieties, *Graduate Studies in Mathematics* **124**, American Mathematical Society, 2011.
- [DRS] J. De Loera, J. Rambau, F. Santos, Triangulations: Structures for Algorithms and Applications, *Algorithms and Computation in Mathematics* **25**, Springer, 2010.
- [D] T. Delzant, Hamiltoniens périodiques et images convexes de l’application moment, *Bull. Soc. Math. France* **116** (1988), 315–339.
- [F] W. Fulton, Introduction to toric varieties, Princeton University Press, 1993.
- [Ga] P. Gauduchon, Hirzebruch Surfaces and Weighted Projective Planes. In: Galicki K., Simanca S.R. (eds) *Riemannian Topology and Geometric Structures on Manifolds*. *Progress in Mathematics* **271**, Birkhäuser, 2009.
- [Gu] V. Guillemin, Moment maps and combinatorial invariants of Hamiltonian T^n -spaces, *Progress in Mathematics* **122**, Birkhäuser, 1994.
- [H] F. Hirzebruch, Über eine Klasse von einfachzusammenhängenden komplexen Mannigfaltigkeiten, *Math. Ann.* **124** (1951), 77–86.

- [KLMV] L. Katzarkov, E. Lupercio, L. Meersseman, A. Verjovsky, The definition of a non-commutative toric variety, *Contemp. Math.* **620** (2014), 223–250.
- [L] E. Lerman, Symplectic cuts, *Math. Res. Lett.* **2** (1995), 247–258.
- [LS] Y. Lin, R. Sjamaar, Convexity properties of presymplectic moment maps, arXiv:1706.00520 [math.SG], (preprint 2017), to appear in *J. Symplectic Geom.*
- [LN] J. Loeb, M. Nicolau, On the complex geometry of a class of non Kählerian manifolds, *Israel J. Math.* **110** (1999), 371–379.
- [LV] S. López de Medrano, A. Verjovsky, A new family of complex, compact, non symplectic manifolds, *Bol. Soc. Brasil. Mat.* **28** (1997), 253–269.
- [M] L. Meersseman, A new geometric construction of compact complex manifolds in any dimension, *Math. Ann.* **317** (2000), 79–115.
- [MV] L. Meersseman, A. Verjovsky, Holomorphic principal bundles over projective toric varieties, *J. Reine Angew. Math.* **572** (2004), 57–96.
- [NR] T. Z. Nguyen, T. Ratiu, Presymplectic convexity and (ir)rational polytopes, arXiv:1705.11110 [math.SG], (preprint 2017).
- [P] E. Prato, Simple non-rational convex polytopes via symplectic geometry, *Topology* **40** (2001), 961–975.
- [S] G. Shephard, Spherical complexes and radial projections of polytopes, *Israel J. Math.* **9** (1971), 257–262.
- [U] Y. Ustinovsky, Geometry of compact complex manifolds with maximal torus action, *Proc. Steklov Inst. Math.* **286** (2014), 198–208.
- [Z] G. Ziegler, Lectures on polytopes, Graduate Texts in Mathematics **152**, Springer, 1995.

Fiammetta Battaglia, Elisa Prato
Dipartimento di Matematica e Informatica "U. Dini", Università di Firenze
Viale Morgagni 67/A, 50134 Firenze, ITALY
fiammetta.battaglia@unifi.it, elisa.prato@unifi.it

Dan Zaffran
College of Marin
835 College Ave, Kentfield, CA 94904, USA
dan.zaffran@gmail.com