



UNIVERSITÀ
DEGLI STUDI
FIRENZE

FLORE

Repository istituzionale dell'Università degli Studi di Firenze

Multi-level optimization of maintenance plan for natural gas system exposed to deterioration process

Questa è la versione Preprint (Submitted version) della seguente pubblicazione:

Original Citation:

Multi-level optimization of maintenance plan for natural gas system exposed to deterioration process / Bahoo, Ahmad; Abaei, Mohammad Mahdi; Arzaghi, Ehsan; BahooToroodi, Farshad; De Carlo, Filippo*; Abbassi, Rouzbeh. - In: JOURNAL OF HAZARDOUS MATERIALS. - ISSN 0304-3894. - STAMPA. - 362:(2018), pp. 412-423. [10.1016/j.jhazmat.2018.09.044]

Availability:

The webpage <https://hdl.handle.net/2158/1138921> of the repository was last updated on 2021-03-31T11:45:55Z

Published version:

DOI: 10.1016/j.jhazmat.2018.09.044

Terms of use:

Open Access

La pubblicazione è resa disponibile sotto le norme e i termini della licenza di deposito, secondo quanto stabilito dalla Policy per l'accesso aperto dell'Università degli Studi di Firenze (<https://www.sba.unifi.it/upload/policy-oa-2016-1.pdf>)

Publisher copyright claim:

Conformità alle politiche dell'editore / Compliance to publisher's policies

Questa versione della pubblicazione è conforme a quanto richiesto dalle politiche dell'editore in materia di copyright.

This version of the publication conforms to the publisher's copyright policies.

La data sopra indicata si riferisce all'ultimo aggiornamento della scheda del Repository FloRe - The above-mentioned date refers to the last update of the record in the Institutional Repository FloRe

(Article begins on next page)

Multi-Level Optimization of Maintenance Plan for Natural Gas System Exposed to Deterioration Process

Ahmad BahooToroody^a, Mohammad Mahdi Abaei^b, Ehsan Arzaghi^b, Farshad

BahooToroody^c, Filippo De Carlo^{a*}, Rouzbeh Abbassi^d,

- a. Department of Industrial Engineering (DIEF), University of Florence, Florence, Italy
- b. National Centre for Maritime Engineering and Hydrodynamics, Australian Maritime College, University of Tasmania, Launceston, Tasmania, Australia
- c. Department of Civil Engineering, University of Parsian, Qazvin, Iran
- d. School of Engineering, Macquarie University, Sydney, NSW, Australia

Abstract

In this paper, a risk-based optimization methodology for a maintenance schedule considering Process Variables (PVs), is developed within the framework of asset integrity assessment. To this end, an integration of Dynamic Bayesian Network, Damage Modelling and sensitivity analysis are implemented to clarify the behaviour of failure probability, considering the exogenous undisciplinable perturbations. Discrete time case is considered through measuring or observing the PVs. Decision configurations and utility nodes are defined inside the network to represent maintenance activities and their associated costs. The regression analysis is considered to model the impact of perturbations on PVs for future applications. The developed methodology is applied to a case study of Chemical Plant (Natural Gas Regulating and Metering Stations). To demonstrate the applicability of the methodology, three cases of seasonal observations of specific PV (pressure) are considered. The proposed methodology could either analyse the failure based on precursor data of PVs or obtain the optimum maintenance schedule based on actual condition of the systems.

Keywords

Risk-based maintenance, Regression tools, Dynamic Bayesian network, Influence diagram, Asset integrity assessment

| Nomenclature | | | |
|---------------|-------------------------------|------------|--|
| Subscripts | | P | Pressure (kPa) |
| PV | Process Variable | λ | expected value of smallest detectable perturbation |
| ROCOF | Rate of OCcurrence Of Failure | D | Actual perturbation |
| F | Failure probability | h | average ROCOF |
| K | State of process variables | f | inflation rate of failure (percentage) |
| CF | Cost of Failure | r | inflation rate of replacement (percentage) |
| CR | Cost of Replacement | r' | inflation rate of repair (percentage) |
| CR' | Cost of Repair | α_i | perturbation parameter |
| CPT | Conditional Probability Table | β_i | perturbation parameter |
| Ω | Sensor uncertainty | A | shape parameter |
| ε | Perturbations | B | scale parameter |

| | | | |
|-------|---|-------|----------------------------------|
| K' | state of process variable before and after maintenance | P_0 | maximum probability of detection |
| O | Observation | LS | Limit state function |
| M | Decision alternative | G | Failure function |
| UF | Utility of Failure (Cost associated with failure) | C | critical PV interval |
| UM | Utility of Maintenance (cost associated with maintenance) | PR | actual PV interval |
| PoD | Probability of Detection | t | time (sec) |

1. Introduction

Since the operational fields of natural gas distribution networks extend far beyond the border of the above ground plant, the safety target community is not limited to the firm's assets but also includes human life and the environment. Over the past few years, significant attention has been paid by researchers to the inclusion of these aspects in the safety and risk assessment of gas distribution pipelines (Dawotola et al. 2013; De Rademaeker et al. 2014; Mannan 2012; Pasma 2015). Up to now, many methodologies have been developed to undertake comprehensive risk analysis of an industrial plant. Tixier et al. (2002) identified 62 methodologies divided into three different phases (identification, evaluation and hierarchy). In order to understand their key features and to categorize them into different classes, the paper examines input data, utilized methods and obtained output data.

There is also a great deal of research on asset integrity management and optimization of maintenance plans (Adriaan et al. 2010; Ahmed et al. 2015; Arunraj and Maiti 2007; Azadeh

et al. 2015; Khan et al. 2006). This has resulted in many innovative methodologies being developed for asset maintenance in the process industry, where the most common classification of the policies based on the time of application and the geographic location of an asset for single or multi-units, are corrective maintenance (CM), preventive maintenance (PM), predictive maintenance, and proactive maintenance (Barnard 2006; Iqbal et al. 2016; Khan et al. 2004; Moubray 1991).

The last two categories have attracted significant attention from researchers for increasing both effectiveness and efficiency of integrity management (Khan and Haddara 2004). Abbassi et al. (2016) developed a risk-based model to integrate predictive and preventive maintenance strategies in an optimal way. It was concluded that the risk-based methodology developed using Bayesian Network (BN) maintains the desired availability and safety level while minimizing the maintenance cost. Bhandari et al. (2016) proposes a methodology for the design of an optimum maintenance program integrating a dynamic risk-based approach in BN. Their method is based on failure prediction and utilizes precursor information in order to revise the risk profile of the system.

BN as a parametric and non-parametric probabilistic method, has been widely used for risk and reliability assessment of complex engineering systems (Barua et al. 2016; Kabir et al. 2015; Yu et al. 2017). Khakzad et al. (2013) demonstrated and compared the application of bow-tie and BN models in conducting quantitative risk analysis of offshore drilling operations. The results of their study show that BN provides more efficient potential than bow-tie models for probabilistic analysis, since it can consider common cause failures and conditional dependencies along with the ability to perform probability updating and sequential learning based on accident precursors data or new available evidence.

Dynamic Bayesian Network (DBN) is a practical extension of static BN whenever an evolving phenomenon must be modelled. In many cases, such as deterioration processes, capturing the dynamic (temporal) behaviour is an important aspect of a modelling process. Daniel Straub (2009) developed a methodology for stochastic modelling of degradation processes. The proposed framework facilitates a robust reliability analysis and Bayesian updating of the model with measurements, monitoring and inspection results. This makes the method highly applicable to near-real time condition monitoring and integrity management.

Another extension to BNs are Influence Diagrams (IDs) which are utilized for developing decision support tools. Conventional graphic-based approaches to decision issues, like Decision Trees, suffer from a number of weaknesses including poor efficiency in representing decision issues with large numbers of parameters and the need for reliable prior information. However, ID are an alternative which are widely established in engineering applications (Abaei et al. 2017; Arzaghi et al. 2017; Friis-Hansen 2000; Luque and Straub 2013).

BN is applied less for considering the impact of exogenous undisciplined perturbations as one of the important concepts of dynamic reliability. Other tools such as diffusion equations and Monte Carlo simulations etc. are widely used to solve these issues (Gao et al. 2011; Rief 1984; Roos et al. 2008). It should be noted that the present study does not aim at developing a fault detection method. Therefore, there is no specific failure event such as a leakage or crack to be detected by the proposed methodology.

The present paper focuses on adopting the Process Variables (PVs) and assessing how their variations can be used for determining the optimum maintenance schedule. That is, what temperature or pressure, for instance, can change the failure rate of a component in the system for which a maintenance task may be essential. Among all contributors, the perturbation plays a pivotal role. It is the amount of deviation from expected steady state condition of normal

operation. A DBN is established to model the damage and the estimation of failure probability distribution, considering the observed trends in PVs. The DBN is then extended to an ID for decision making regarding the optimum maintenance interval as well as the maintenance type. A risk-based approach is selected for proposing the methodology and to demonstrate its application. Developing a risk-based maintenance policy for a Natural Gas Reduction Station in Florence, Italy is considered.

The remainder of the paper is organized as follows. In the first section the fundamentals of BNs are discussed. Section 2 presents the details of the proposed methodology. Section 3 is devoted to the application of the methodology while the concluding remarks of the paper are presented in Section 4.

1.1. Bayesian Network, Dynamic Bayesian Network and Influence Diagram

1.1.1. Bayesian Network

A detailed discussion on probabilistic knowledge elicitation using BN with a wide range of engineering applications is presented by (Barber 2012; Neapolitan 2004; Scutari 2014). BN is a strong tool to incorporate the deterministic data into the probabilistic model with robust connections to graph theory. Based on the capability of including different types of uncertainty (aleatory and epistemic), BN is recognised as a promising method for risk analysis of complex systems. BN is also able to incorporate both causes and consequences of the failure event in a single network.

BN is a Directed Acyclic Graph (DAG) in which the nodes (random variables) are interconnected with arcs that represent probabilistic dependencies among variables. For instance, **Fig. 1** presents a schematic BN where node X_3 is a child of X_1 and X_2 ; nodes X_1 and X_2 are considered as parent nodes of X_3 . Each node consists of a conditional probability table (CPT).

Based on the conditional independencies and the chain rule, BN estimates the joint probability distribution of a set of random variables given in Eq. (1).

$$P(X_1, X_2, \dots, X_n) = \prod_{i=1}^n P(X_i | Pa(X_i)) \quad (1)$$

As an example, the joint probability distribution of the random variables X_1, X_2 and X_3 shown in **Fig. 1** is estimated by $P(X_1, X_2, X_3) = P(X_1)P(X_2)P(X_3|X_1, X_2)$

In case new information becomes available for one or more chance nodes, BN is able to update the joint probability distribution based on the Bayes' theorem given in Eq. (2):

$$P(X|E) = \frac{P(X, E)}{\sum_X P(X, E)} \quad (2)$$

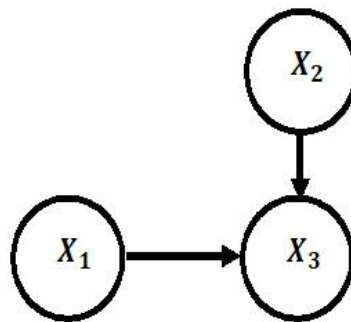

Fig. 1. A schematic Bayesian Network

1.1.2. Dynamic Bayesian Network

DBN represents a stochastic process as a sequence of several time slices, each consisting of inter-dependent nodes. As an illustration, if the BN in **Fig. 1** is expanded into multiple time slices $t = \{1, \dots, T\}$, a DBN will be constructed, as shown in **Fig. 2**.

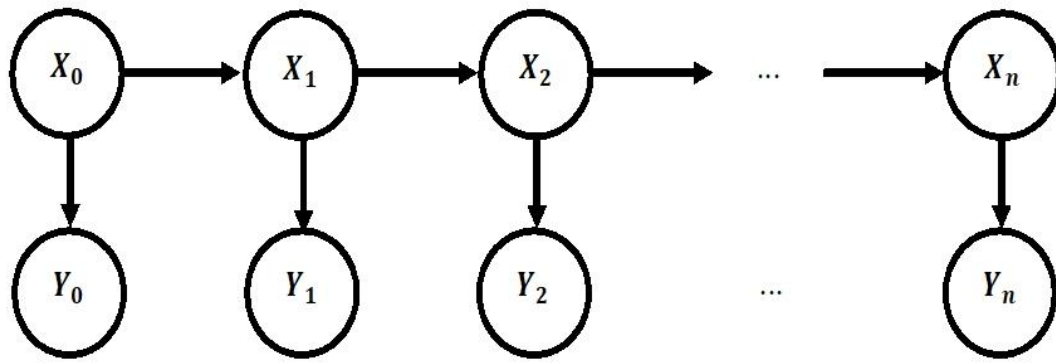

Fig. 2. Example of Dynamic Bayesian Network

1.1.3. Influence Diagram

An ID can be established by including utility nodes (diamonds) and decision nodes (rectangles) into a BN (see Fig. 3). A decision node consists of several decision alternatives available to the user. Since the parents of a decision node incorporate the required information at the time of the decision, the arc pointing to a decision node is an information arc, not an expression of probabilistic dependency. Utility nodes are the descendants of either chance nodes and/ or decision nodes and have no successors. The utility values (including benefits or losses) of a utility node are determined as the preference of the user/operator over each configuration of the decision alternatives and those chance nodes that are the parents of the utility node. Once the ID is completely formed for a decision issue, the expected utility of each decision alternative can be estimated. The optimal decision is the one that maximizes the total expected utility, in agreement with classical decision analyses.

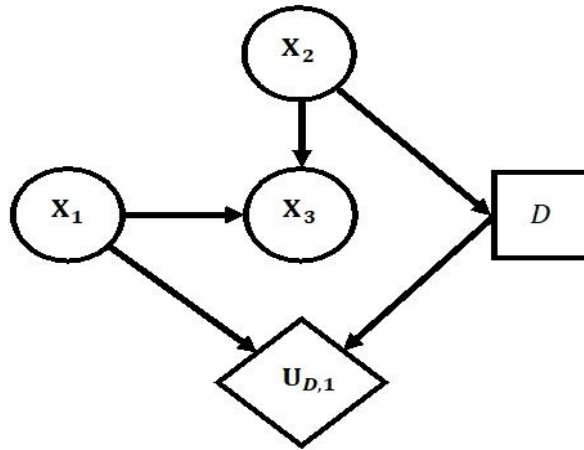

Fig. 3. An Influence Diagram including utility and decision nodes (X : chance nodes, D : decision node, U : utility node)

2. Methodology

In this study, a framework for stochastic modelling of dynamic process using DBN is developed. The steps of the developed methodology are illustrated in **Fig. 4** and discussed in detail in the following sections. The model can be used in different applications for estimating the failure rates based on precursor data and for optimising the maintenance schedules using a risk-based approach.

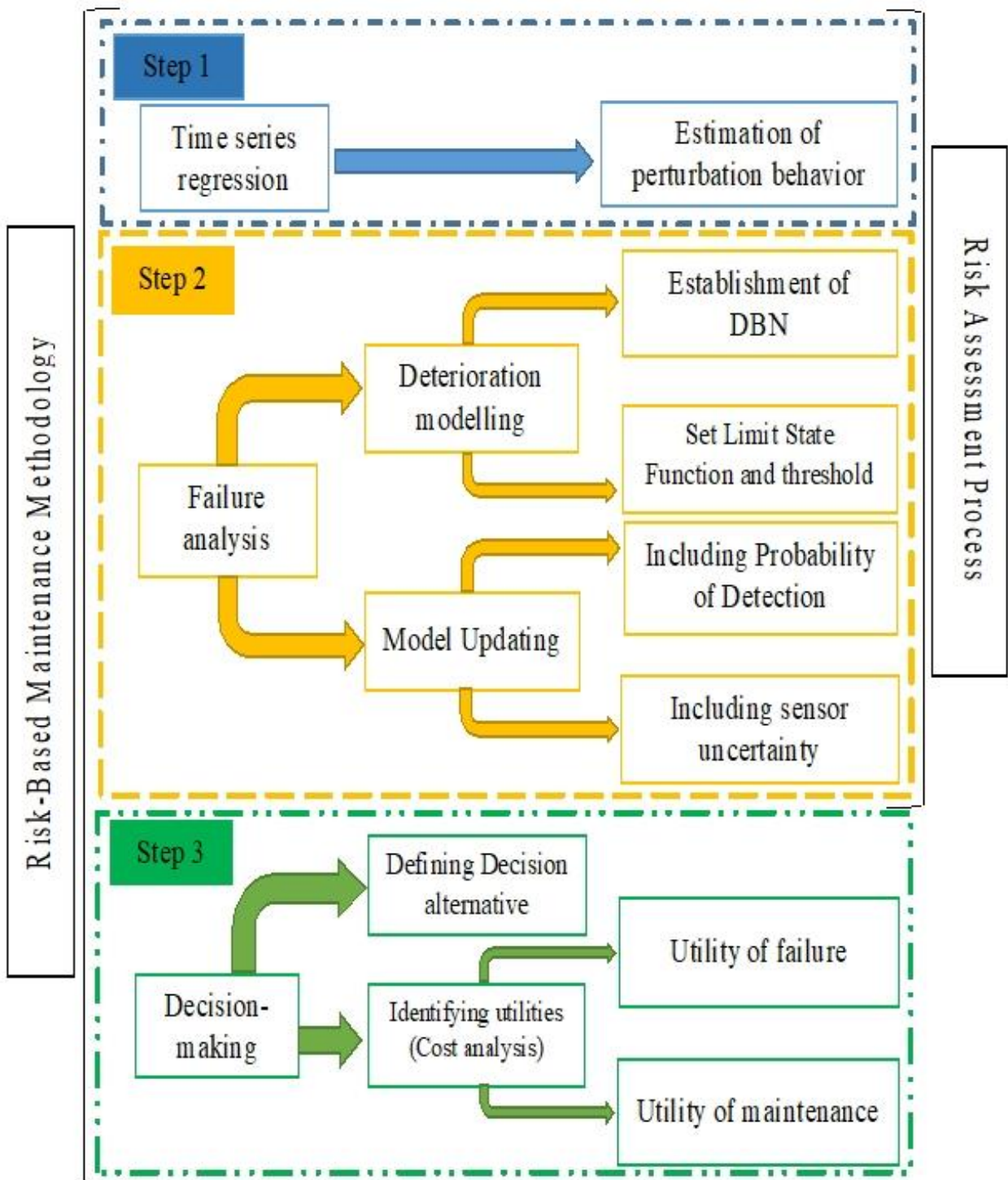

Fig. 4. Developed methodology for maintenance planning based on PV behavior and impacts of exogenous perturbations

2.1. *Function time series prediction*

The proposed methodology aims at developing a dynamic model that represents the changes in PVs over time. Both mathematical and statistical modelling are applied to predict the behaviour of PVs (more explanation is referred to in (Roffel and Betlem 2006; Tinsley and Brown 2000)). According to the quality and type of available data the suitable prediction tool differs.

2.2. *Failure analysis*

Consider a DBN model that describes the condition of PVs before and after applying a set of perturbations. Failure analysis has been developed to assess the related failures. For the purpose of this class, two subsections will be presented in detail.

2.2.1. *PVs Monitoring Mechanism modelling*

The generic DBN model for stochastic modelling of PVs is represented in [Fig. 5](#). The proposed DBN is applied as a generalization of Markov process models. In a Markov process, the future is independent on the past, given the present, as given in Eq. (3). Here the Markov process is modelled as a chain of nodes that represent the PV.

$$P(X_{t+1}|X_t, \dots, X_0) = P(X_{t+1}|X_t) \quad (3)$$

In order to ensure that the DBN is homogenous with identical time slices, the arcs connecting nodes $[\mathcal{E}_1, \dots, \mathcal{E}_T]$ are considered. The transition between these nodes are modelled with diagonal matrices resulting in $\mathcal{E}_t = \mathcal{E}_{t-1}, t = \{2, \dots, T\}$ (similar assumption is implemented for Ω). This is performed to facilitate the model building process and for a better graphical presentation of the model. As suggested by Daniel Straub (2009), these arcs have no impact on the computational efficiency of the model.

Although the model here is proposed in general, the numbers of PVs can vary based on the demand of application with times as:

$$K^j(t) \in K^j = \{K_1^j, K_2^j, \dots, K_t^j\}; j = 1, \dots, n \quad (4)$$

For instance, temperature or vibration can be the PV modelled with this method. Owing to the fact that updating in the light of new evidence is counted as a feature of the present model, observations can be adopted from each $K^j(t)$, as given in Eq. (5):

$$O^j(t) \in O^j = \{O_1^j, O_2^j, \dots, O_t^j\}; j = 1, \dots, n; \quad (5)$$

where j is the number of observation and i indicates the PV being monitored. The same condition is assumed for the extent and type of perturbation variables such as system perturbation and exogenous perturbation, see Eq. (6).

$$\mathcal{E}_q; q = 1, 2, \dots, x \quad (6)$$

The model has n time slices representing the entire process time divided into discrete number of time steps. All the distributions of variables with continuous analytical expression are discretized into a number of mutually exclusive states. The univariate discretization is proposed so that the continuity in the probability distributions is achieved precisely. More detail of the discretization process of the variables is explained in the following sections.

2.2.2. Model specification

Each perturbation parameter has a stationary process and consequently its probability distribution does not change when shifted in time ($\mathcal{E}_t = \mathcal{E}_{t-1} = \mathcal{E}, t = 2, \dots, T$). Therefore, the parameters of the suitable probability distribution must be estimated only once and the CPT of perturbation can be filled after discretization of the final distribution. It is suggested that for the sake of simplicity and without loss of generality, the perturbation data be fitted to a Normal distribution.

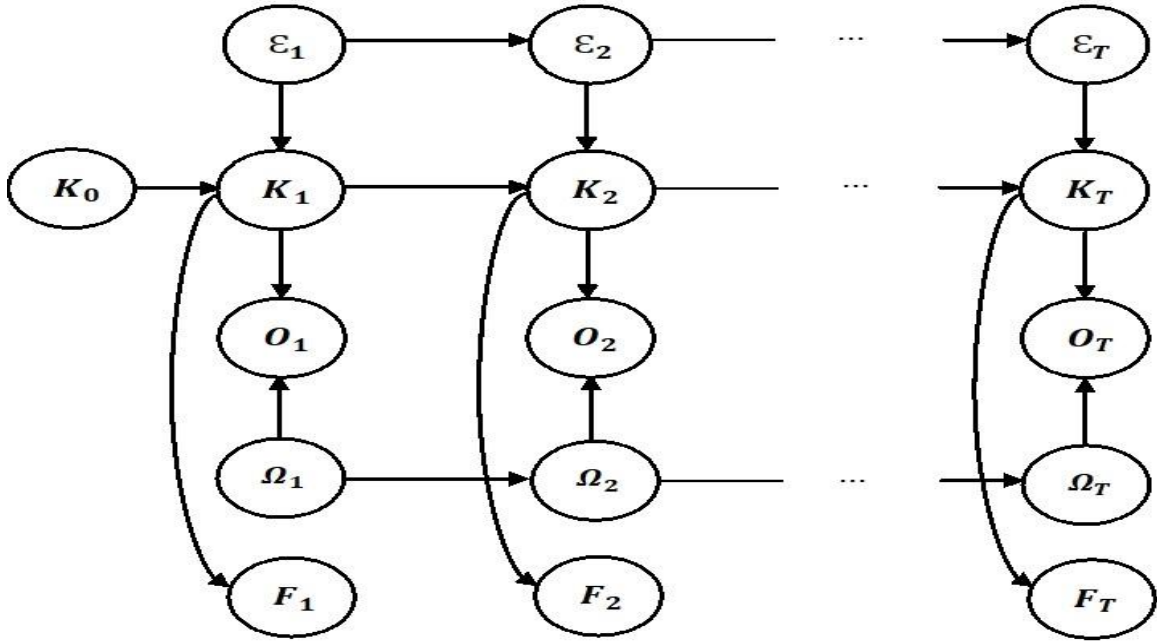

Fig. 5. Developed DBN for stochastic modeling of process of PVs under impact of exogenous perturbations. Network nodes are, ϵ : perturbations, K : state of PV, O : observations, Ω : sensor uncertainty, F : Failure.

To obtain the Probability Density Function (PDF) of PV elements in the first time slice, the historical data should be analysed. The available database contains lower and higher bounds and fault threshold rates. Based on the trend and the extreme values, the most suitable distribution for the data can be figured out by several methods such as Maximum Likelihood Estimation (MLE), or Least-Squares Estimation (LSE). MLE has been recommended in previous research (Myung 2003), since it has many features such as efficiency in the calculations, consistency and parameterization invariance. As a result, the MLE is adopted in the present study and the PDF of PVs is accordingly discretized.

The CPT of PVs ($P(K_i | K_{i-1}, \epsilon_i)$) is defined with binary values based on the limit state concept. These binary values are presented in $N \times N \times M$ transition probabilities, where N and M are the state numbers of K_i and ϵ_i , respectively. Limit state function is discussed further, later in this section. In order to fill the transitional CPTs, it is necessary to define a safe

operational interval for the considered PV. For instance, the interval $[a, b]$ can be chosen to determine whether the PV is within this interval. It is through this comparison that CPTs can be filled, as given in Eq. (7):

$$CPT = \begin{cases} \text{if } a \leq PV \leq b \text{ then} & 0 \\ \text{else} & 1 \end{cases} \quad (7)$$

The DBN model used in the proposed methodology provides the user with an opportunity to consider new evidence to update the probability distributions. Observations can be made from many strategies such as real time monitoring and failure monitoring. In the present study, inspection results are incorporated into the network and the uncertainty associated with the results is characterized by Probability of Detection (PoD), D. Straub (2004) provides a number of PoD functions based on empirical methods. A common approach to define the PoD function is the one-dimensional exponential threshold model, previously used by several researchers, (Ambühl 2017; J. S. S. Nielsen, J. D. 2011; J. S. Nielsen and Sørensen 2017; D. Straub 2004) and given by:

$$PoD(D) = P_0 \left[1 - \exp\left(-\frac{D}{\lambda}\right) \right] \quad (8)$$

where D is as the actual perturbation, P_0 the maximum probability of detection and λ is the expected value of the smallest detectable perturbation.

In order to complete the PoD model, probability distributions are discretized into E states. It should be noted that the number of states for node O should be the same as the states of node K . The discretized probabilities are set in the first column of the $N \times E$ ($N = E$) matrix. The perturbation in the former states of PV cannot be detected as damage in the latter states of inspection (for example the perturbation value in K_1 is not detectable in O_2 or O_3). So, the final CPT of $P(O_i | K_i)$ is as follows:

$$\begin{bmatrix} PoD_1 & 0 & 0 & \dots & 0 & 0 \\ PoD_2 & PoD_2 & 0 & \dots & 0 & 0 \\ \cdot & \cdot & \cdot & \dots & \cdot & \cdot \\ \cdot & \cdot & \cdot & \dots & \cdot & \cdot \\ \cdot & \cdot & \cdot & \dots & \cdot & \cdot \\ \cdot & \cdot & \cdot & \dots & \cdot & \cdot \\ PoD_{N-1} & PoD_{N-1} & PoD_{N-1} & \dots & PoD_{N-1} & 0 \\ PoD_N & PoD_N & PoD_N & \dots & PoD_N & 1 \end{bmatrix} \quad (9)$$

The method for estimating PoD in other time slices (from the second time slice onwards) is different from the first, since these nodes have an extra parent node which is the node incorporating the uncertainty of sensors. Although PoD function is applied to model the reliability of inspection, the uncertainty of sensor values can be represented in three forms, from no attention to uncertainty at all, to the highest resolution of uncertainty information: point uncertainty, interval uncertainty and probabilistic uncertainty (Cheng 2003). In the present paper, probabilistic uncertainty approaches are adopted.

Considering Ω_i , the model reflects the reliability of sensors as well. As a general concept of this work (as done for perturbation), normal distribution is proposed as the suitable probability distribution being fitted to uncertainty of sensors, however, other distributions can be adopted based on the available data and characteristics of sensors. This parameter is time-invariant, so, the calculation of PDF and discretized value of probability must be done only once for the whole process.

Assuming that N and E are the state numbers of O_i and K_i subsequently, and L is the number of states (S) in node Ω_i , the final CPT of $P(O_i | K_i, \Omega_i)$ is shown in Eq. (10) in the form of $[N \times E] \times [L]$:

$$\begin{bmatrix}
1 - \frac{1}{N}\Omega & 0 & 0 & \dots & 0 & 0 \\
0 & 1 - \frac{2}{N}\Omega & 0 & \dots & 0 & 0 \\
0 & 0 & 1 - \frac{3}{N}\Omega & \dots & 0 & 0 \\
\vdots & \vdots & \vdots & \dots & \vdots & \vdots \\
\vdots & \vdots & \vdots & \dots & \vdots & \vdots \\
\vdots & \vdots & \vdots & \dots & \vdots & \vdots \\
0 & 0 & 0 & \dots & 1 - \frac{N-1}{N}\Omega & 0 \\
\frac{1}{N}\Omega & \frac{2}{N}\Omega & \frac{3}{N}\Omega & \dots & \frac{N-1}{N}\Omega & 1
\end{bmatrix} \times [S_1, S_2, \dots, S_L] \quad (10)$$

Failure probability is assessed using limit state function (Kamphuis 2000). This approach is adopted as follows here:

$$G = C - PR \quad (11)$$

where G is failure function, C is critical PV interval and PR is the actual PV interval. Consequently, the conditional probability of failure $P(F_i | K_i)$ in the DBN is expressed with two states of Safe and Fail, 1 (fail) if $G \leq 0$ and 0 (safe) when $G > 0$.

2.3. Decision making support tool

The next stage of the methodology is to develop an ID for optimising the maintenance. The ID developed in this paper (see [Fig. 6](#)) incorporates the socio-economic aspects including operation and maintenance costs into the decision-making process. As discussed in section 1.1.3, two additional node types, utility and decision nodes, are added to the DBN for constructing the ID.

The decision node (M_i) characterizes different decision alternatives (repair, replace, continue without any maintenance actions). It is made based on the results of inspections and subsequently it affects its descendent including the chance node ($K'(t)$). The nodes $K'(t)$ are introduced into the network for discriminating between the status of the PV before and after a

decision regarding maintenance. In case the decision is made to continue without any maintenance actions, the CPTs of $K'(t)$ nodes are identical to that of $K(t)$ node from the same time slice. This is while the CPTs vary if maintenance (repair or replace) is carried out in the previous time slice.

It should be noted that if a decision is made for repairing or replacing the system, the state of PV will be recovered to its initial time steps. The value of recovery is directly depending on the norms and practices in the industry of interest.

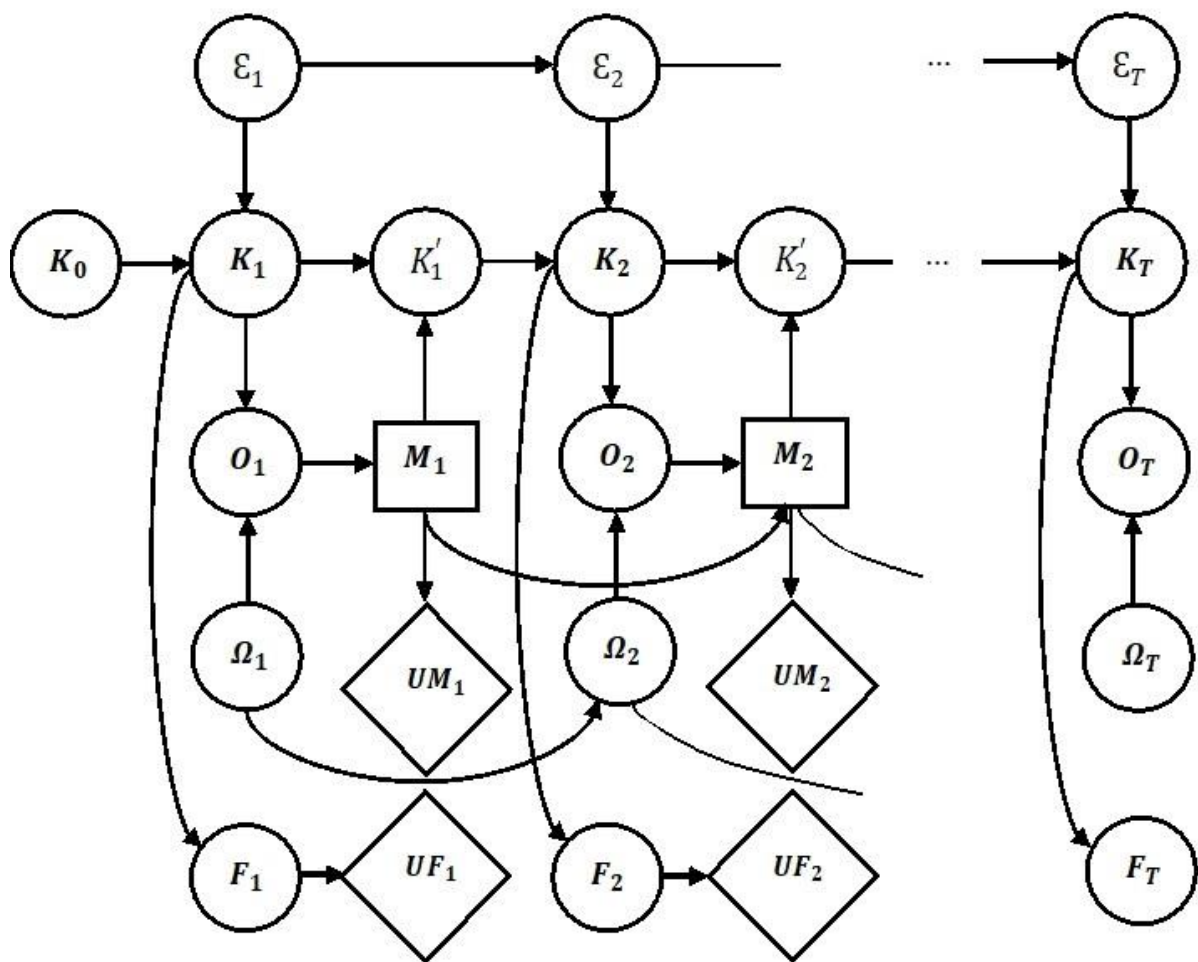

Fig. 6. The ID of the multi-criteria decision-making model developed for maintenance planning of a stochastic process. Network nodes are, ϵ : perturbations, K : PVs condition, K' : PVs condition after maintenance, O : observations, Ω : device uncertainty, F : Failure, M : Maintenance, UM : utility of maintenance, UF : Utility of Failure

The costs associated with system failure are accounted for using the utility of failure (UF_i node) in the network. The initial time slices can be filled based on the amount of collected data from the structure. The inevitable cost of failure in the future periods of operation is given by (Usher et al. 1998):

$$CF_j = \overline{CF} \cdot \bar{h}_j (1 + f)^j \quad (12)$$

Where cost of failure (CF) in period (j) is estimated by a simple Rate of Occurrence Of Failures (ROCOF) constant, \overline{CF} (in units of \$/unit-failure-rate) multiplied by the average ROCOF, (\bar{h}). It is also assumed that the cost of a failure taking a place in future will be subjected to inflation at a rate of f percent in the considered period of j . For the sake of simplification, it is suggested a linear approximation be considered for the average of ROCOF (Referred to Usher et al. (1998) for more explanations).

The utility values developed for maintenance alternatives are suggested to be evaluated in detail separately for each configuration. The cost of replacement of the equipment is estimated as:

$$CR_j = \overline{CR} (1 + r)^j \quad (13)$$

where CR is a constant cost for replacing the equipment. In the present paper, the values for CR are adopted from historical data. Similar to the case of failure, a separate inflation rate (r) is considered for replacements over the period j .

Finally, if the system requires a repair, the regular cost for this activity (CR') will be affected by an inflation rate of r' percent per period, therefore the cost of repair is given by Equation 14.

$$CR'_j = \overline{CR'} (1 + r')^j \quad (14)$$

3. Application of developed methodology: Case study

An example of Natural Gas Regulating and Metering Stations (NGRMS) is given to show how the application of developed ID in risk-based maintenance can be applied. GeNie software is used as a tool for modelling the ID. A detailed discussion on application of each step of the developed methodology in the case study is discussed in the following sections.

3.1. Scenario development

NGRMS are established in the gas distribution networks to reduce the Natural Gas outlet pressure to a setting value. To handle the process, there are two regulating streams with two regulators arranged in a series for each line. One is the main regulator and the other is used as a control/slam shut valve. Through the normal operation, one line is working while the other line is on stand-by. If main and slam regulator (both) fail, the other standby line starts to work. As illustrated in Fig. 7, the standard configurations of lines in NGRMS are made up of control valve, pressure regulator-passive controller, main pressure regulator with a built-in slam-shut valve and filters.

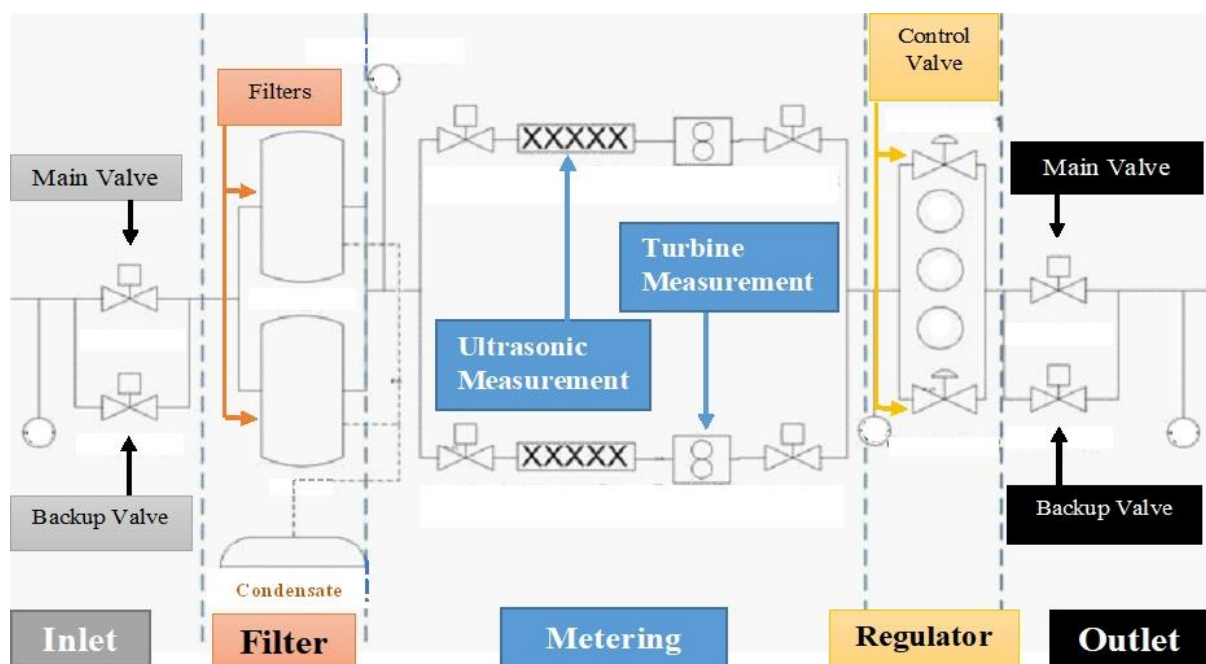

Fig. 7. Simple System Architecture of NGRM stations

The requirements for particular characteristics of delivered gas, including gas specification, odorisation and pressure are specified in both local and international regulations. (see (UNI 2009a, 2009b, 2012)). Such regulations are issued to obtain smooth operations with the lowest possible number of maintenance interruptions, failure losses and accidental damages. In the present study, the pressure is applied as PV to analyse the deterioration process and to finally achieve the optimal time schedule of maintenance.

3.2. Function prediction

To set up the decision making process, the pressure values during 36 months of process operation were taken into account. The time series predictions are depicted in Fig. 8 along with historical and validation data. The historical data is predicted by different regression tools to find the most suitable one based on their predictive performance. In this study, the competitive evaluation of models summed up and selected Fourier as the suitable one due to stable results across samples with below representation (see Eq.(15)).

$$P(t) = \alpha_0 + \sum_{i=1}^{\infty} \left(\alpha_i \cos \frac{i\pi t}{L} + \beta_i \sin \frac{i\pi t}{L} \right) \quad (15)$$

Where first term of Fourier equation (α_0) is actually the expected amount of observed pressure since it is defined by Equation 16.

$$\alpha_0 = \frac{1}{T} \int_0^T P(t) = \bar{P} \quad (16)$$

Based on historical data, it can be reckoned that although the process engineering gives protection for pressure behaviours against perturbations, there are nevertheless a wide range of perturbations in the pressure. These perturbations can be modelled by regression tools of

pressure through time. As a result, α_i and β_i are considered as independent perturbation parameters and follow from:

$$\varepsilon = \{\alpha_i, \beta_i; i = 0, 1, \dots, 6\} \quad (17)$$

$$\alpha_i = \frac{1}{T} \int_0^T P(t) \cos \frac{i\pi t}{L} \quad (18)$$

$$\beta_i = \frac{1}{T} \int_0^T P(t) \sin \frac{i\pi t}{L} \quad (19)$$

By taking pressure (including perturbation) into account, the condition of pressure is predicted in time based on its initial treatments. Each α and β in the model experienced a normal distribution with specific mean (μ) and standard deviation (σ^2). So Eq. (15) can be represented as:

$$P(t) = \bar{P} + \sum_{i=1}^{\infty} \left(\frac{1}{\sqrt{2\pi\sigma_i^2}} e^{-\frac{(\alpha_i - \mu_i)}{2\sigma_i^2}} \cos \frac{i\pi t}{L} + \frac{1}{\sqrt{2\pi\sigma_i^2}} e^{-\frac{(\beta_i - \mu_i)}{2\sigma_i^2}} \sin \frac{i\pi t}{L} \right) \quad (20)$$

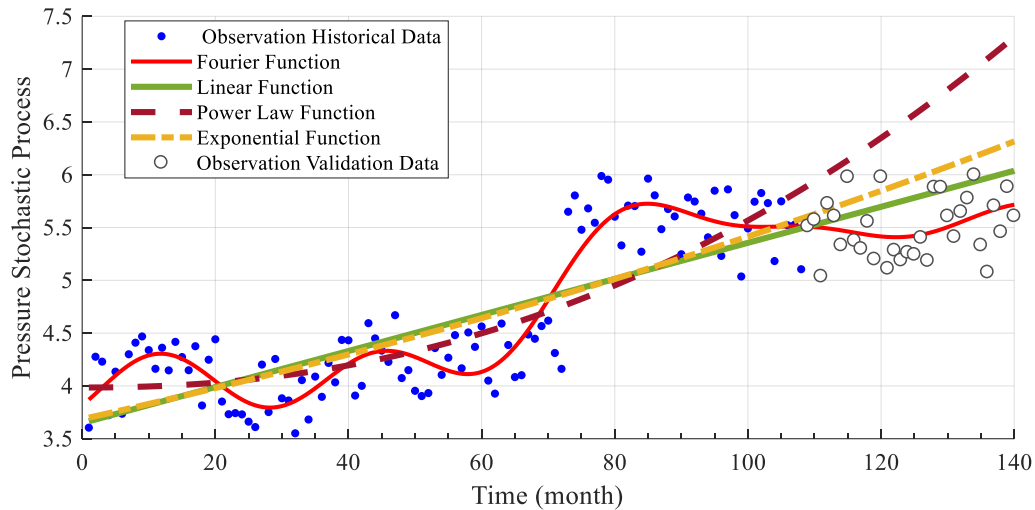

Fig. 8. Time series ahead prediction of Pressure treatment

3.3. Pressure monitoring model

To demonstrate the time dependent stochastic modelling of a PV (pressure), a DBN model is developed (see Fig. 9). For the purpose of this study, the model is simplified by analysing the pressure behaviour for a period of four seasons (each season representing a time slice; P_0, P_1, \dots, P_4) with influence of exogenous perturbations on it. Although in reality, the system will often be maintained (repaired or replaced) at a fixed time, especially after detection of failure, in the method presented in section 2.2, it is assumed that the system has not been maintained for three years.

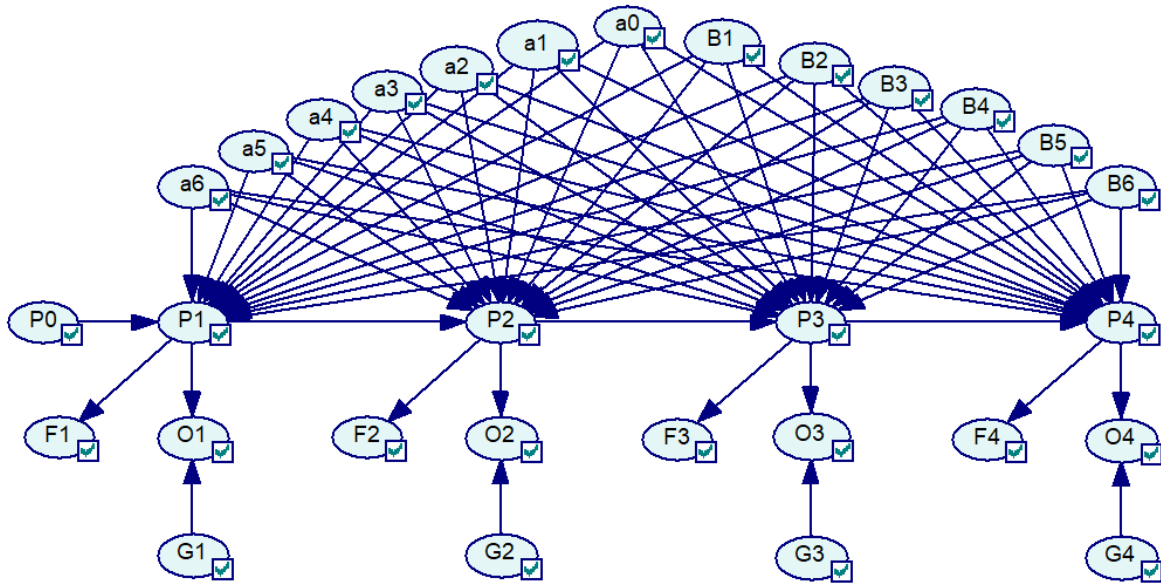

Fig. 9. Developed DBN model including exogenous perturbations for four seasons. Network nodes are, $\{\alpha_0, \alpha_1, \dots, \alpha_6, \beta_1, \beta_2, \dots, \beta_6\}$:perturbations, P_0 : Initial Pressure condition, P : Pressure condition, O : observations, G : device uncertainty, F : Failure

The parameter P_0 accounts for the initial pressure (historical data of pressure) and has a Weibull distribution with scale and shape parameters of A and B respectively. It is assumed that both parameters have negligible deviation and a constant rate of $A = 4.455$ and $B = 10.244$. On

the contrary, other parameters applied in the model are normally distributed. The distribution of each parameter mentioned in [Table 1](#) is split into a specific number of intervals. In addition to these parameters, the observation node is similarly discretised using 10 intervals while avoiding round-off errors by using MATLAB software (see [Fig. 10](#)).

It should be mentioned that pressure size in the following time slices are discretized using the same uniform interval lengths as P_0 . A detailed discussion of the sequence of filling the CPTs for all parameters (pressure size $P(P_i | P_{i-1}, \mathcal{E}_i)$, observation $P(O_i | P_i, \Omega_i)$, and failure $P(F_i | P_i)$) is stated in section [2.2.2](#).

Table 1: Parameters of stochastic modelling of pressure with perturbations variables

| Variable | Description | Distribution (discretized interval) | Mean | Standard deviation |
|-----------------|--|--|-------------|---------------------------|
| α_0 | 1 st Perturbation parameter | Normal (5) | 4.885 | 3.118 |
| β_1 | 2 nd Perturbation parameter | Normal (5) | -0.638 | 3.031 |
| α_1 | 3 rd Perturbation parameter | Normal (5) | -0.6945 | 2.8985 |
| β_2 | 4 th Perturbation parameter | Normal (5) | -0.11 | 0.3829 |
| α_2 | 5 th Perturbation parameter | Normal (5) | -0.7374 | 5.6264 |
| β_3 | 6 th Perturbation parameter | Normal (5) | 0.2462 | 1.7332 |
| α_3 | 7 th Perturbation parameter | Normal (5) | -0.2168 | 2.5258 |
| β_4 | 8 th Perturbation parameter | Normal (5) | 0.0346 | 3.5336 |
| α_4 | 9 th Perturbation parameter | Normal (5) | -0.0044 | 0.9305 |

| | | | | |
|------------|---|------------|---------|--------|
| β_5 | 10 th Perturbation parameter | Normal (5) | 0.1719 | 1.1268 |
| α_5 | 11 th Perturbation parameter | Normal (5) | 0.0515 | 0.6279 |
| β_6 | 12 th Perturbation parameter | Normal (5) | 0.1096 | 0.561 |
| α_6 | 13 th Perturbation parameter | Normal (5) | -0.0989 | 2.4919 |
| Ω | Devices uncertainty | Normal (3) | 0.0002 | 0.05 |

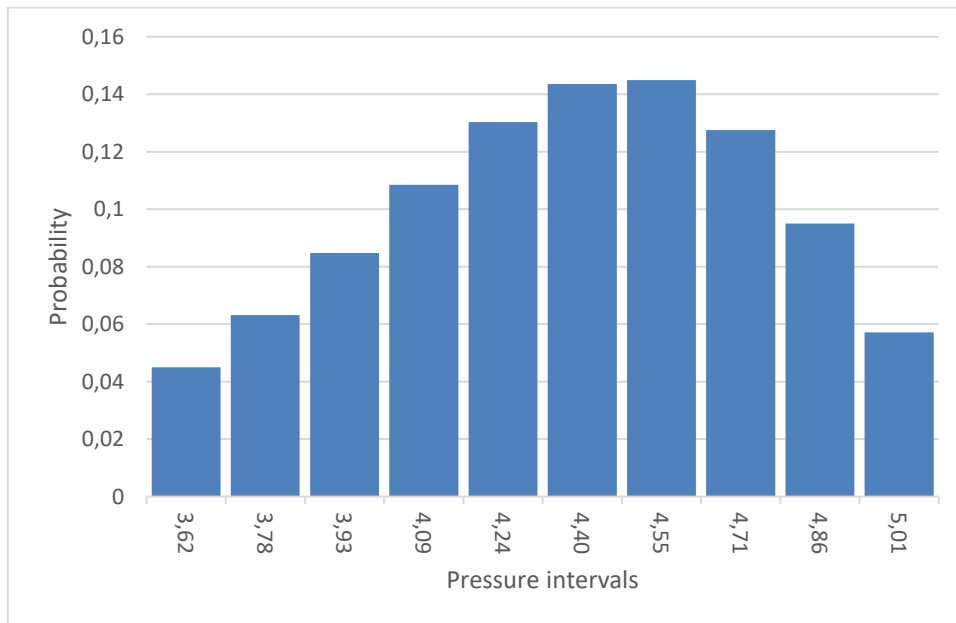

Fig. 10. Discretized Weibull Distribution of initial pressure size

3.4. Utility efficiency

Recognizing the optimal maintenance strategies and times are conducted by an extension of DBN into ID (see Fig. 11; due to space limitation nodes P_0 to P_2 of the decision model are only depicted). To evaluate the effect of maintenance on process, the maintenance alternatives are defined consequently in three actions including continue, repair and replace. The elements of drawn ID were previously introduced in section 2.3

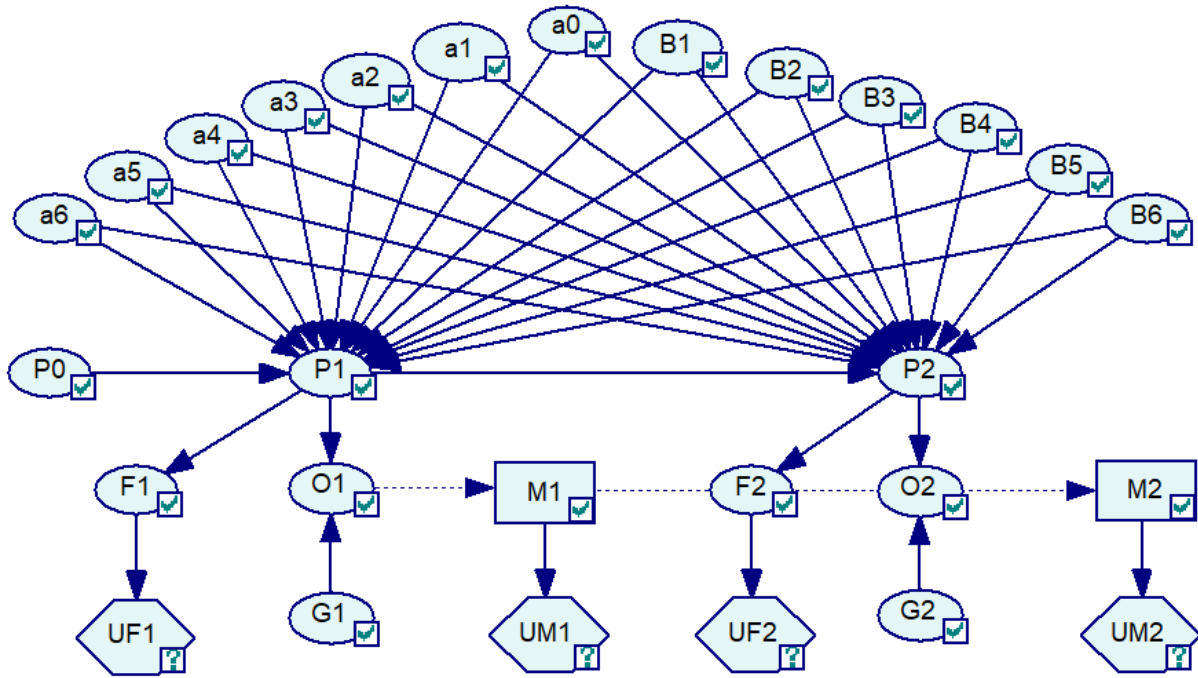

Fig. 11. Developed Influence Diagram for maintenance planning considering exogenous perturbations. Network nodes are $\{\alpha_0, \alpha_1, \dots, \alpha_6, \beta_1, \beta_2, \dots, \beta_6\}$: perturbations, P_0 : Initial Pressure condition, P : Pressure condition, O : observations, G : device uncertainty, F : Failure M : Maintenance, UF : Utility of Failure UM : Utility of Maintenance

Iqbal et al. (2016) presented a comprehensive review on inspection and maintenance policies for oil and gas pipelines. They defined the repair of a unit as Imperfect maintenance after which, although the unit is not taken into account as new, it is supposed to be younger than before. The replacement is also assumed to be established either at complete failure or after fixed number of failures. To improve the effectiveness of the decision making process, the hybrid policies have been examined with mentioned decision alternatives later.

Based on aforementioned assumptions and Eq.(13) and Eq. (14), the costs associated with repair and replacement are compared and depicted in Fig. 12. The line graph illustrates the repair value and bar chart represents the replacement expenses for the entire domain of pressure (as illustrated in Fig. 10. the pressure variable is discretised in 10 intervals). Units are measured in Euros.

Overall, the expected cost is changing through different intervals for repair, while experiencing constant rate for replacement. It is proved again that the most desired pressure value is starting from the third and finishing at the fifth interval as the repair costs decline and rise significantly before and after these intervals. Additionally, it is necessary to note that steady rate of replacement cost does not mean that for any conditions of pressure in any time of replacement, the expected cost would be the same. This will be explained in detail in the following section by considering different occasions.

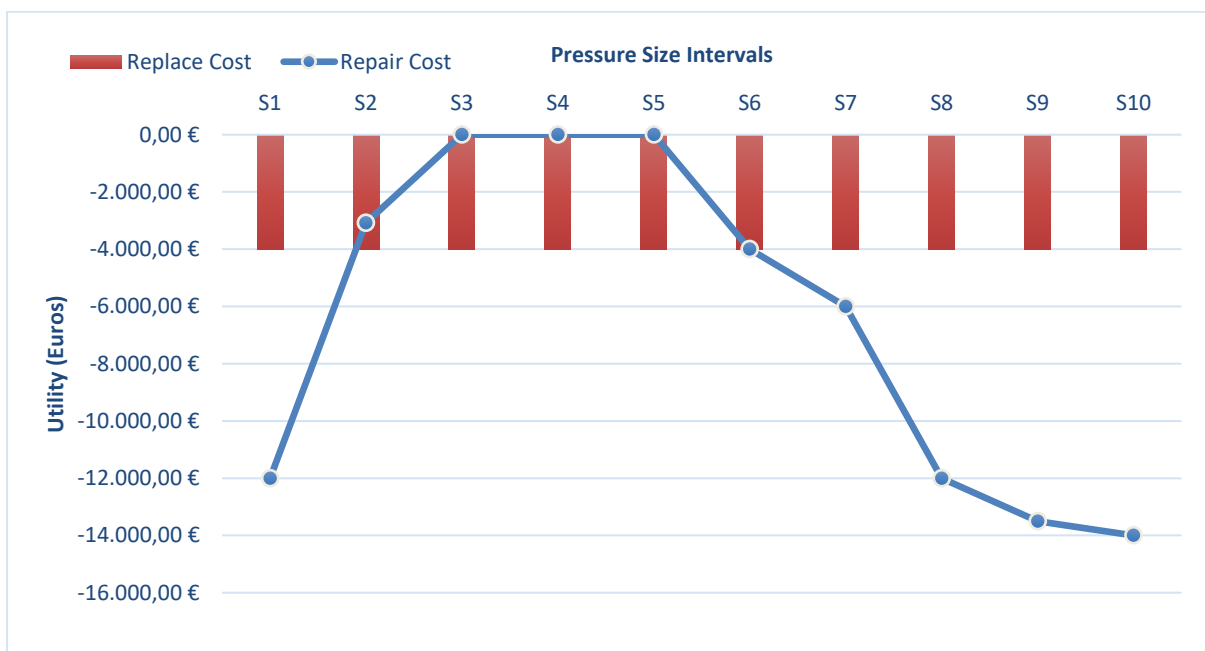

Fig. 12. Utility value of maintenance alternatives, repair and replace, for each interval of pressure

3.5. Influence Diagram application: results

To assess the advantage of the developed methodology, three different seasonal inspection cases were considered. To make clear reported data in [Table 2](#), in case B, the observations are made with a pressure in state 2 followed by state 7 of pressure intervals in the third season. The health of the system is not monitored for the second and last seasons.

Table 2: Observations of pressure size in the NGRM station. Three cases of different monitoring results were considered. Note: the cells with dashes illustrate times where monitoring is not performed.

| Month | 3 | 6 | 9 | 12 |
|--------------|----------|----------|----------|-----------|
| Case A | State 1 | State 6 | State 8 | - |
| Case B | State 2 | - | State 7 | - |
| Case C | State 8 | - | - | - |

The line graphs in **Fig. 13**, **Fig. 14** and **Fig. 15** depict the Expected Utility (EU) for three maintenance alternatives (repair, replace and continue) based on inspection results reported in **Table 2** over a period of one year.

Starting with case A, the deterioration is mapped through the gradual increase of pressure from its 1st state to 6th and lastly 8th state. Although at the beginning of the considered period, continuing the operation is the most beneficial option, the subsequent drop of EU in this line at the second season implies that this is not an appropriate alternative after six months. Based on results depicted in **Fig. 13**, it is deduced that the optimal strategy is continuing at the first season, followed by repairing at the second stage. The utility of all three options for the final season is predicted to be approximately equal. Ultimately, according to the model, the maximum benefits are achieved if in the 3rd and 4th seasons replace and continue alternatives are applied respectively, where the EU reaches a peak of 12000 and 1000 Euros.

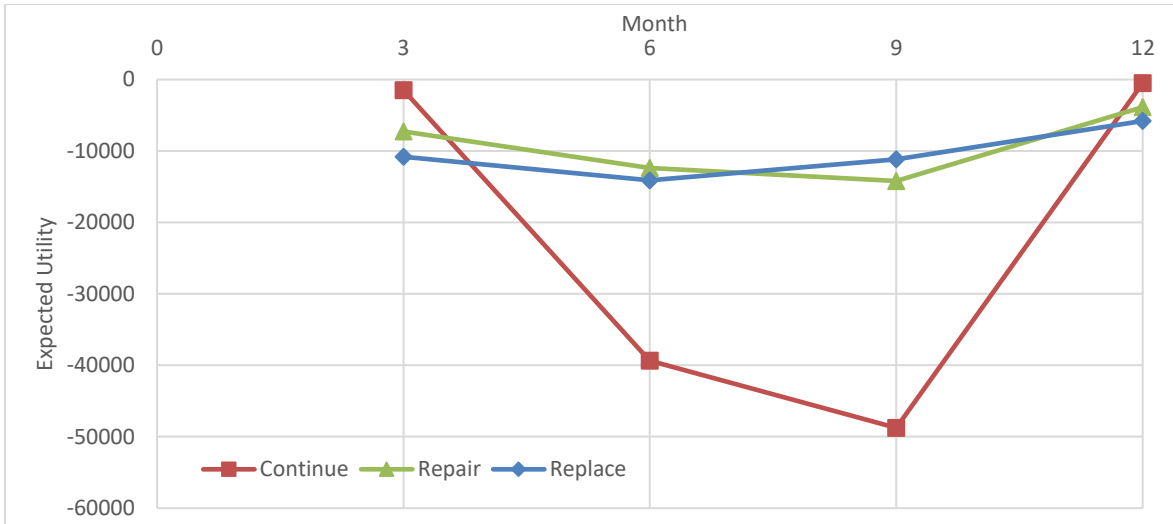

Fig. 13 Expected utilities of three decision alternatives: Replace, Repair and Continue operation for case (A) with different pressure size incidents as detailed in table 2

In case B, continuing the operation is considered as the best configuration of maintenance decision in the first 2 seasons. As can be seen in Fig. 14, since the pressure experienced its 7th interval at the end of the 9th month, it is proposed that the system must undergo a repair process at the third season to recover its healthy state. This action has the maximum EU of approximately 15000 € at 3rd season NGRMS. Similar to case A, it is predicted that conducting the suitable maintenance policy optimizes the EU in the upcoming season.

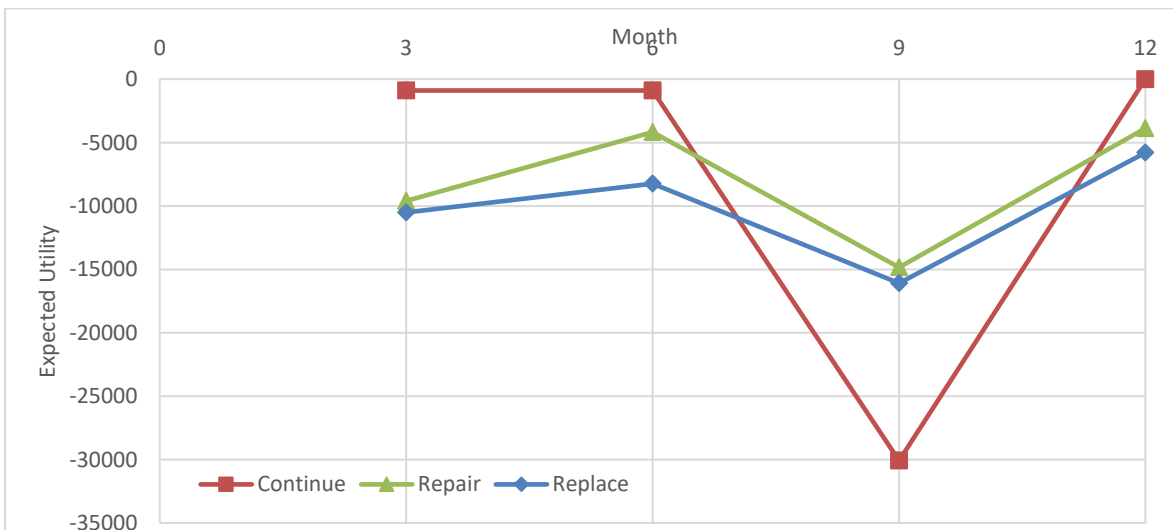

Fig. 14. Expected utilities of three decision alternatives: Replace, Repair and Continue operation for case (B) with different pressure size incidents as detailed in table 2

Considering Case C (illustrated in Fig. 15), the EU of continue option, deviates noticeably over the period given, while for the other two alternatives it changes minimally. Considering the status of pressure in the first season, the model assesses the EU of replace as the optimal alternative where it reaches a peak of about 4000 Euros. Executing this decision configuration will result in a surge in EU of other options in the future, this trend can be seen chiefly through continue to the end of studied time.

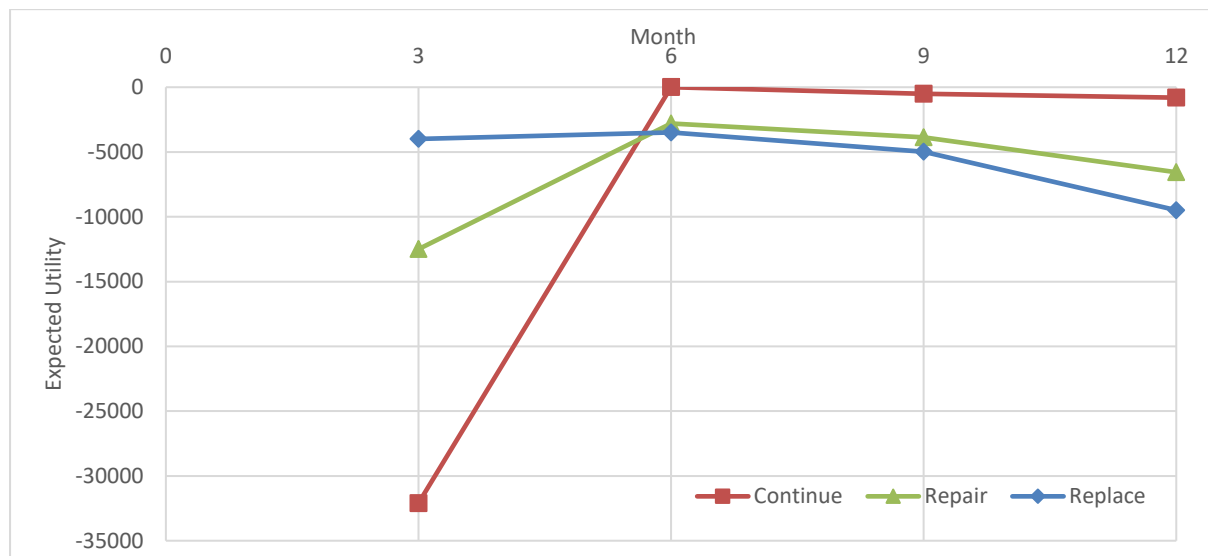

Fig. 15. Expected utilities of three decision alternatives: Replace, Repair and Continue operation for case (C) with different pressure size incidents as detailed in table 2

4. Conclusion

A novel methodology using Markov degradation model as an underlying principle of decision making is developed to estimate the optimal maintenance time schedule. The treatment of PVs under the influence of perturbations in time series has been analysed applying DBN and ID. Furthermore, the proposed approach enables investigating uncertainty related to parameters, models and historical data through limit state function. The failure mode has also been explained in a limit state equation. The model has been enabled to update the probability based on new observation of system. The reliability of inspection has been characterized by PoD through one-dimensional exponential threshold model. In addition to model the reliability of

inspection, the uncertainty of sensor values is also represented. The expected cost associated with failures and maintenances is estimated considering inflation. The study has been implemented on actual examples of stochastic deterioration process of Natural Gas Regulating and Metering Stations (NGRMS) in order to validate the proposed method using real field data. The pressure has been taken into account as PV. The Fourier series is used as the regression tool to predict the trend of pressure considering perturbation parameters in time. To examine the method, three different seasonal inspection cases have been introduced into the network to determine the optimum maintenance times and strategies. Present risk-based maintenance method has the capability of improving the maintenance schedule considering different PVs, however it can be integrated with other reliability models leading to reduce the uncertainty of final results.

5. References

- Abaei, Mohammad Mahdi, et al. (2017), 'Developing a novel risk-based methodology for multi-criteria decision making in marine renewable energy applications', *Renewable Energy*, 102, 341-48.
- Abbassi, A., et al. (2016), 'Developing a Quantitative Risk-based Methodology for Maintenance Scheduling Using Bayesian Network', *CHEMICAL ENGINEERING TRANSACTIONS*, 48, 6.
- Adriaan, V. H., Liliane, P., and Peter, M. (2010), 'Maintenance optimization models and criteria', *International Journal of System Assurance Engineering and Management*, 1 (3), 12.
- Ahmed, Qadeer, et al. (2015), 'A multi-constrained maintenance scheduling optimization model for a hydrocarbon processing facility', *Proceedings of the Institution of Mechanical Engineers, Part O: Journal of Risk and Reliability*, 229 (2), 151-68.

- Ambühl, S.; Sørensen, J.D. (2017), 'On Different Maintenance Strategies for Casted Components of Offshore Wind Turbines;' *DCE* (222: Aalborg: Department of Civil Engineering, Aalborg University).
- Arunraj, N. S. and Maiti, J. (2007), 'Risk-based maintenance--techniques and applications', *J Hazard Mater*, 142 (3), 653-61.
- Arzaghi, Ehsan, et al. (2017), 'Risk-based maintenance planning of subsea pipelines through fatigue crack growth monitoring', *Engineering Failure Analysis*, 79, 928-39.
- Azadeh, A., et al. (2015), 'Selection of optimum maintenance policy using an integrated multi-criteria Taguchi modeling approach by considering resilience engineering', *The International Journal of Advanced Manufacturing Technology*.
- Barber, D. (2012), *Bayesian Reasoning and Machine Learning* (Cambridge University Press).
- Barnard, I. (2006), *Asset management – An insurance perspective* (Engineering Asset Management: Springer.).
- Barua, Shubharthi, et al. (2016), 'Bayesian network based dynamic operational risk assessment', *Journal of Loss Prevention in the Process Industries*, 41, 399-410.
- Bhandari, Jyoti, et al. (2016), 'Dynamic risk-based maintenance for offshore processing facility', *Process Safety Progress*, 35 (4), 399-406.
- Cheng, R. & Prabhakar, S. (2003), 'Managing uncertainty in sensor databases. ', *SIGMOD Record issue on Sensor Technology*.
- Dawotola, Alex W., et al. (2013), 'Risk-Based Maintenance of a Cross-Country Petroleum Pipeline System', *Journal of Pipeline Systems Engineering and Practice*, 4 (3), 141-48.
- De Rademaeker, Eddy, et al. (2014), 'A review of the past, present and future of the European loss prevention and safety promotion in the process industries', *Process Safety and Environmental Protection*, 92 (4), 280-91.

- Friis-Hansen, A. (2000), 'Bayesian Belief Networks Bayesian Belief Networks Application', (Technical University of Denmark).
- Gao, Wei, et al. (2011), 'Hybrid probabilistic interval analysis of bar structures with uncertainty using a mixed perturbation Monte-Carlo method', *Finite Elements in Analysis and Design*, 47 (7), 643-52.
- Iqbal, Hassan, et al. (2016), 'Inspection and maintenance of oil & gas pipelines: a review of policies', *Structure and Infrastructure Engineering*, 13 (6), 794-815.
- Kabir, Golam, Sadiq, Rehan, and Tesfamariam, Solomon (2015), 'A fuzzy Bayesian belief network for safety assessment of oil and gas pipelines', *Structure and Infrastructure Engineering*, 12 (8), 874-89.
- Kamphuis, J. William (2000), *Introduction to Coastal Engineering and Management* ed. Philip L- F Liu (Cornell University) (ADVANCED SERIES ON OCEAN ENGINEERING: World Scientific Publishing Co. Pte. Ltd.).
- Khakzad, Nima, Khan, Faisal, and Amyotte, Paul (2013), 'Quantitative risk analysis of offshore drilling operations: A Bayesian approach', *Safety Science*, 57, 108-17.
- Khan, F. I. and Haddara, Mahmoud (2004), 'Risk-based maintenance (RBM): A new approach for process plant inspection and maintenance', *Process Safety Progress*, 23 (4), 252-65.
- Khan, F. I., Sadiq, R., and Haddara, M. M. (2004), 'Risk-Based Inspection and Maintenance (RBIM)', *Process Safety and Environmental Protection*, 82 (6), 398-411.
- Khan, F. I., Haddara, M. M., and Bhattacharya, S. K. (2006), 'Risk-based integrity and inspection modeling (RBIIM) of process components/system', *Risk Anal*, 26 (1), 203-21.
- Luque, J. and Straub, D. (2013), 'Algorithms for optimal risk-based planning of inspections using influence diagrams', *11th International Probabilistic Workshop IPW11* (Brno University of Technology, Brno, Czech Republic.).

- Mannan, S. (2012), *Lees' Loss Prevention in the Process Industries (Fourth Edition)* (Oxford: Butterworth-Heinemann).
- Moubray, J., & Lanthier, J. (1991), *reliability centered maintenance ii* (Oxford: Butterworth-Heinemann).
- Myung, In Jae (2003), 'Tutorial on maximum likelihood estimation', *Journal of Mathematical Psychology*, 47 (1), 90-100.
- Neapolitan, R.E. (2004), *Learning Bayesian Networks* (Pearson) 674.
- Nielsen, J. S. & Sørensen, J. D. (2011), 'On risk-based operation and maintenance of offshore wind turbine components', *Reliab. Eng. Syst. Saf.*, 96, 9.
- Nielsen, Jannie S and Sørensen, John D (2017), 'Bayesian estimation of remaining useful life for wind turbine blades', *Energies*, 10 (5), 664.
- Pasman, Hans (2015), 'Loss Prevention History and Developed Methods and Tools', 79-184.
- Rief, Herbert (1984), 'Generalized Monte Carlo perturbation algorithms for correlated sampling and a second-order Taylor series approach', *Annals of nuclear energy*, 11 (9), 455-76.
- Roffel, B.; and Betlem, B. (2006), *Process Dynamics and Control Modeling for Control and Prediction* (Wiley).
- Roos, Hans-Görg, Stynes, Martin, and Tobiska, Lutz (2008), *Robust numerical methods for singularly perturbed differential equations: convection-diffusion-reaction and flow problems* (24: Springer Science & Business Media).
- Scutari, M. (2014), *Bayesian Network Structure Learning, Parameter Learning and Inference*
- Straub, D. (2004), 'Generic Approaches to Risk-Based Inspection Planning for Steel Structures.', (Swiss Federal Institute of Technology—ETH Zurich: Zurich, Switzerland).

- Straub, Daniel (2009), 'Stochastic Modeling of Deterioration Processes through Dynamic Bayesian Networks', *Journal of Engineering Mechanics*, 135 (10), 1089-99.
- Tinsley, ; and Brown, S. D. (2000), *Handbook of Applied Multivariate Statistics and Mathematical Modeling* (Elsevier) 721.
- Tixier, J., et al. (2002), 'Review of 62 risk analysis methodologies of industrial plants', *Journal of Loss Prevention in the Process Industries*, 15, 14.
- UNI (2009a), 'Impianti di ricezione, prima riduzione e misura del gas naturale. progettazione, costruzione, collaudo', *UNI 9167 ; 2009*.
- (2009b), 'UNI EN 334 2009_Regolatori di pressione del gas per pressioni di entrata fino a 100 bar ', *UNI EN 334 ; 2009*.
- (2012), 'infrastrutture del gas Condotte con pressione massima di esercizio non maggiore di 16 bar, part 1 ', *UNI EN 12007-1*.
- Usher, John S., Kamal, Ahmed H., and Syed, Wasim Hashmi (1998), 'Cost optimal preventive maintenance and replacement scheduling', *IIE Transactions*, 30 (12), 1121-28.
- Yu, H., Khan, F., and Veitch, B. (2017), 'A Flexible Hierarchical Bayesian Modeling Technique for Risk Analysis of Major Accidents', *Risk Anal.*