

# A REALLY INNOVATIVE FREIGHT BOGIE

Andrea BRACCIALI and Gianluca MEGNA

Department of Industrial Engineering, University of Florence, Italy  
Via Santa Marta 3, 50139, Florence, Italy

*Received: September 9, 2019*

## ABSTRACT

A new bogie for freight wagons, named 4L (“*four legs*”) is introduced, aiming at fighting against Y25 in terms of cost, running dynamics behaviour, track friendliness and maintainability. Compatibility with existing vehicles was kept. Structural, dynamics and contact mechanics analyses are discussed, showing how the 4L bogie is definitely the winner of this battle.

*Keywords:* Y25 bogie, freight wagons, bogie frame, AIR Wheelset, running dynamics, contact mechanics, 4L bogie

## 1. INTRODUCTION

Even if the Y25 bogie has recently celebrated the 50<sup>th</sup> anniversary from its first development [1], it is still the most common freight bogie in Europe. The main reason can be found in the low manufacturing and maintenance costs, which have strongly reduced the possibility of the application of innovative solutions. However, the increase of the efficiency of goods transport by means of freight wagons is one of the main objectives for the next years and projects are dedicated to develop an innovative freight bogie with superior characteristics respect to current Y25 bogie [2] [3]. Several aspects have to be involved in this process, with special attention to wagon design, monitoring and maintenance. As lower noise, greater load capacity, lower downtime and better ride quality are requested today by railway companies, bogie designer have to face very challenging problems. This is confirmed by considering that the state of the art of freight bogies, composed by improved design of Y25 (like the GB25RS or the TVP2007) or advanced new design (like the RC25NT, the DRRS25LD or the TF25), is not able to completely replace the classic design of Y25, even if greater performances could be guaranteed in terms of safety, speed and reliability.

In this paper an innovative freight bogie, named 4L (“*four legs*”) for its peculiar structure, is described considering its impact on freight wagon market. Differently from other modern bogies, the 4L shows a better ride quality by means of its suspension arrangement and its lightweight design, without the need of rubber cushions or hydraulic dampers.

## 2. DESCRIPTION OF THE Y25, LEILA AND 4L BOGIE

Freight wagons are typically allowed to travel with a maximum cant deficiency of 92 mm (non-compensated acceleration  $a_{nc}=0.6$  m/s<sup>2</sup>), while they can stop in canted curves with a maximum cant excess of 160 mm ( $a_{nc}=-1.05$  m/s<sup>2</sup>). In any case, lateral

forces are one order of magnitude lower than vertical forces, that are due to gravity ( $\cong 10 \text{ m/s}^2$ ).

To better understand the differences of the solutions compared in this chapter, Figure 1 shows the position of the applied vertical force (in the centre bowl) and the position of the bogie frame reactions in the Y25 bogie, in the Leila bogie and in the 4L bogie (described below). Obviously closer reaction points generate less bending and are easier to react.

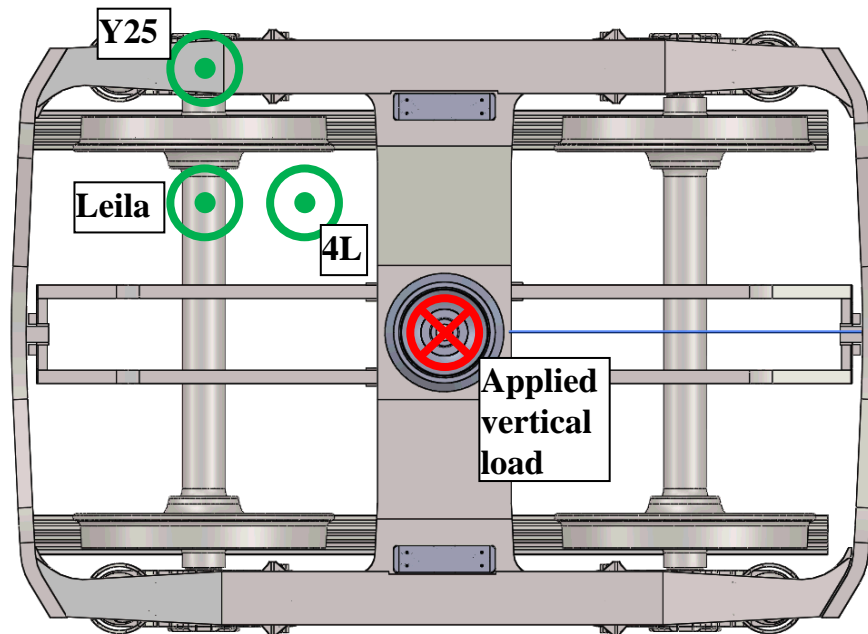

Fig. 1 Comparison of reaction forces on the bogie frame for three different bogie architectures. It can be seen that the Y25 bogie has the farthest reaction point while the 4L bogie has the closest reaction point.

Starting from the Y25 bogie frame and limiting the analysis to vertical loads, the flow of the forces is shown in Figure 2. As a general rule, it is known that every time a force is shifted laterally bending appears. The path followed by vertical load acting on the centre bowl shows that the elements of the Y25 bogie are subjected to bending, requiring a beam-like structure.

The second case considered relates to bogies with inside frame design (i.e. with inboard bearings wheelsets). The most famous bogie representative of this category is certainly the Leila bogie by Prof. Markus Hecht from TU Berlin (Figure 3), designed to replace the Y25 offering superior performances.

The Leila bogie frame has a shorter bolster beam, leaving the side beams nearly unaffected. However, one of the most important benefits of inboard bearings solutions is that the bending on the axle is reversed, and the overall stresses on the axle are relieved by curving forces. Regardless an extensive testing campaign and the

presentation to Innotrans trade fair in 2004 and 2006, to the authors' knowledge the mass production of the Leila bogie did not start yet.

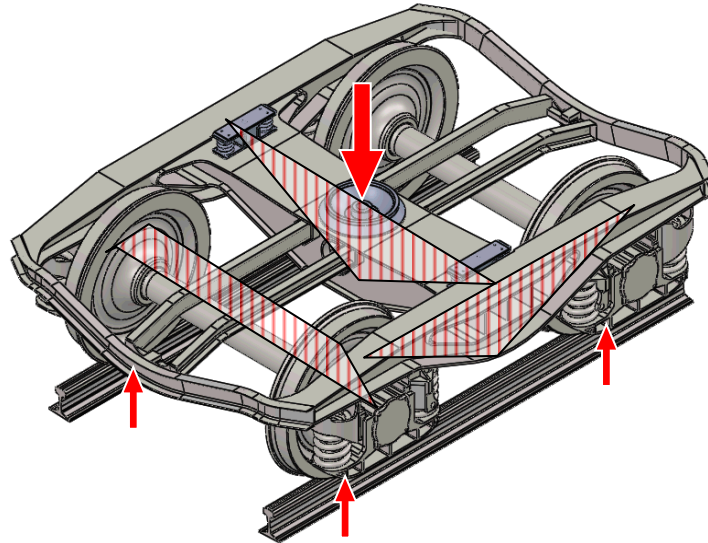

Fig. 2 Path of the vertical force in Y25 bogie. The bolster and the side beams are subject to bending. Axle bending is worsened in curves, where flange forces increase the stresses in this component

Before discussing the bogie introduced in this paper, it is worth observing the forces acting on a generic bogie. The vertical force, applied at the centre of the sphere of the centre bowl ( $z \cong 900$  mm) is reacted by the forces at the wheel-rail contact, with  $\Delta x = 1800$  mm and  $\Delta y = 1500$  mm. The resulting almost right angle “pyramid”, shown in Figure 4, cannot nevertheless be applied to real bogies with inboard bearings, as the wheelsets must be connected elastically to the bogie frame by using springs of any kind.

An architecture that can shorten the bogie frame is the one of the Wegmann-Kassel bogie (Figure 5), that was used quite extensively in the ‘60s and in the ‘70s especially for sleeping cars due to its good ride quality properties. It can be seen that in this case the bogie frame becomes much shorter than the similar conventional bogie (e.g. approximately 1900 mm vs. 3000 mm for a 2500 mm wheelbase bogie) as twice the length of the horizontal part of the swinging arm must be subtracted to the wheelbase.

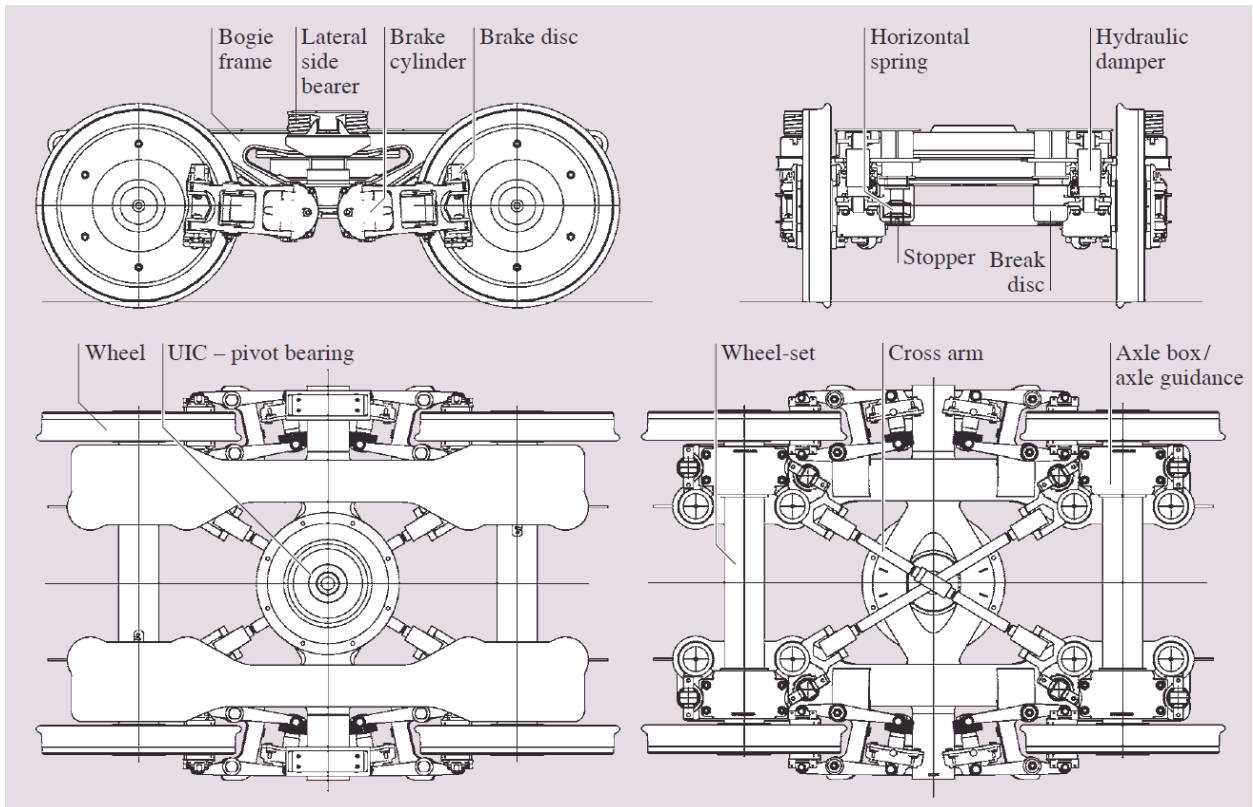
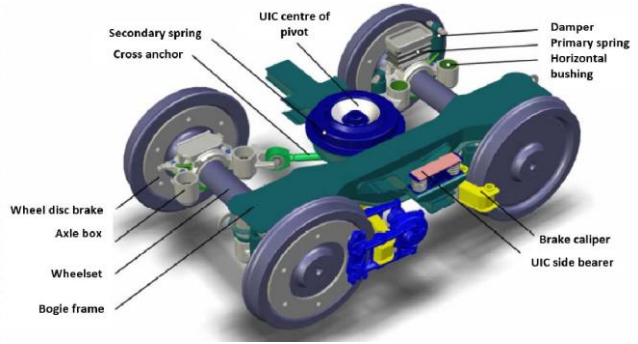
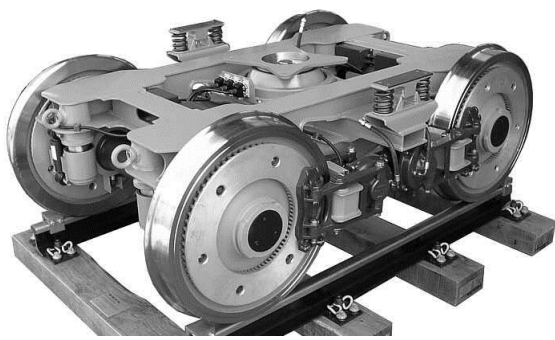

Fig. 3 The Leila bogie, with inboard bearings wheelsets, web-mounted disc brakes, Gigabox primary suspension, two levels of suspension and cross-bracing (lower figure from Grote Antonsson - Springer Handbook of Mechanical Engineering, ch. 13.3 Railway Systems – Railway Engineering)

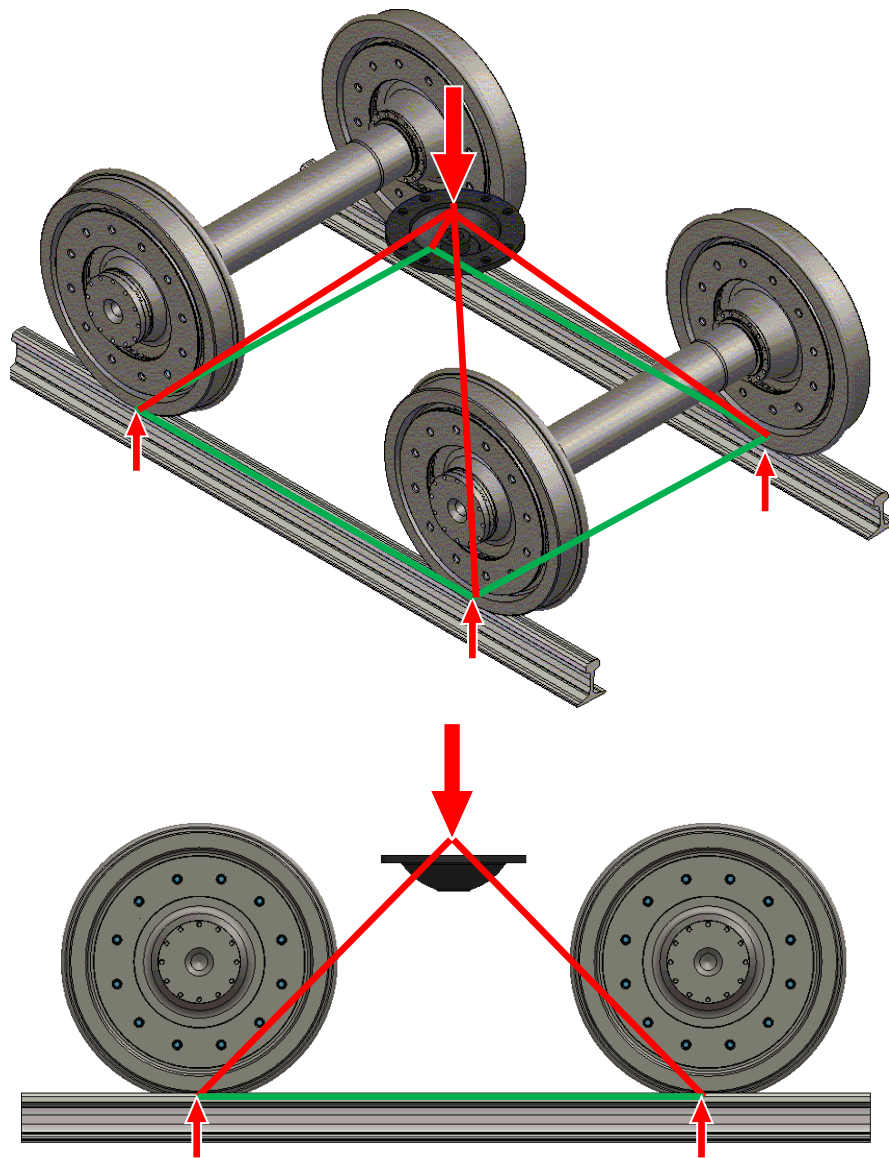

Fig. 4 Sketch of the reactions to the vertical force applied to the centre bowl of a freight wagon.

The 4L bogie, introduced in this paper (Figure 6), is an inboard bearings bogie in which the primary suspension acts in longitudinal direction as done in the Wegmann-Kassel bogie, with the innovation that each spring connects the two swinging arms on one side and consequently the two wheelsets, replacing the eight springs used on each side of an Y25 bogie. Therefore, vertical movements of the wheelset and the bogie are transformed in horizontal movements by the swinging arm and energy is dissipated by friction (load dependent) in the cylindrical pin connection between the arm and the frame. The cylindrical pin is composed by wear resistance elements (manganese steel or wear-resistant austempered ductile iron).

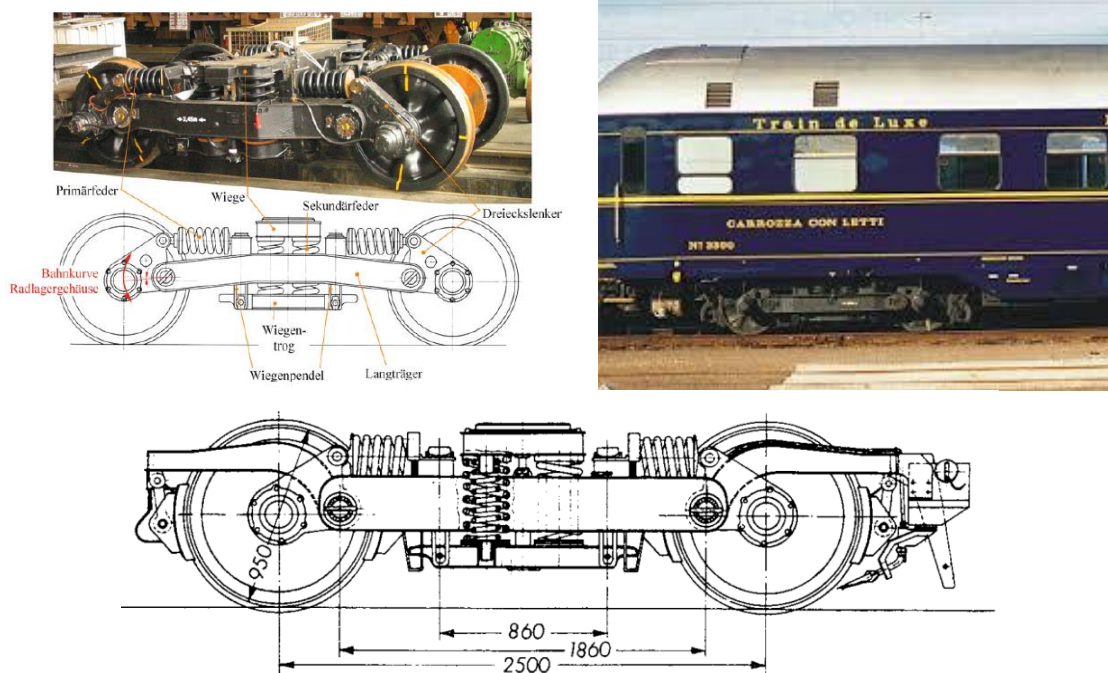

Fig. 5 Top: the Wegmann-Kassel (also know as the München-Kassel) bogie, with swinging arms and horizontal primary suspension (from J. Ihme – Schienenfahrzeugtechnik - Springer Vieweg Verlag 2016, pp. 183-184). Bottom: drawing taken from K. Sachs – Elektrische Triebfahrzeuge, Springer Verlag, 1973.

This solution seemed very attractive especially for running dynamics reasons. As it will be shown below, the vertical static stiffness of the 4L bogie is identical to the Y25 bogie with the differences that the force-displacement curve is smooth, and a peculiar behaviour is obtained under certain conditions described below, resulting in a dynamic equivalent stiffness lower than the static one. This leads to a superior behaviour about running dynamics properties of the 4L bogie compared to the Y25 under these circumstances. Moreover, the absence of components requiring specific maintenance (such as hydraulic dampers) is a distinct advantage of this solution that is made only of steel.

The greatest structural advantage of the 4L bogie is that the vertical force is transferred to the joints with a pyramidal structure made of “trusses”, i.e. the eight elements of the bogie frame are four “legs” (from which the name of the bogie) in compression and four elements at the base in tension. The latter were made torsionally soft for reasons described below. The 4L bogie with the axlebridges of the AIR wheelsets [6] (with wheels removed) is shown in Figure 7.

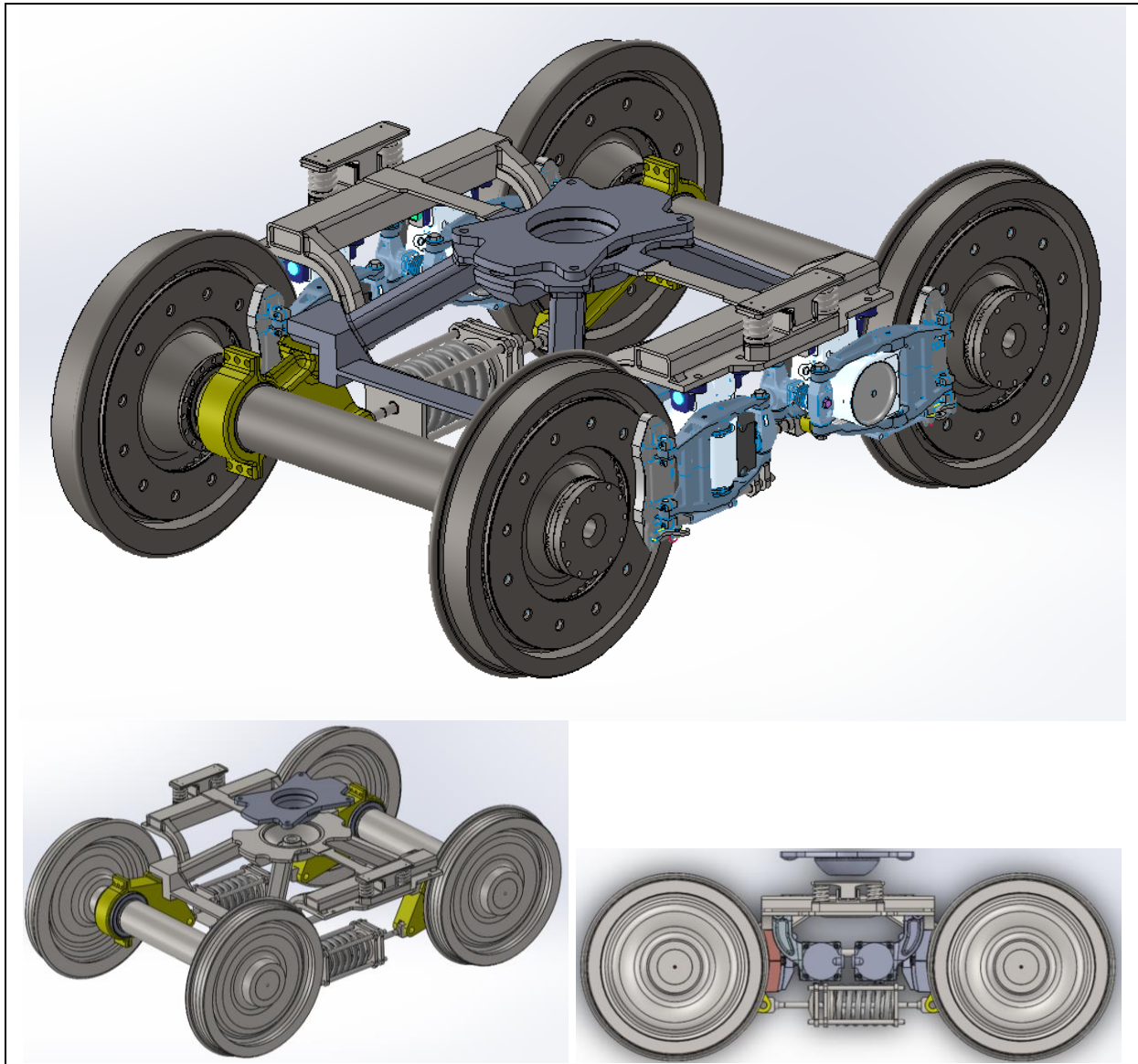

Fig. 6 Top: the 4L bogie with web-mounted brake discs and AIR Wheelsets (mass  $\cong$  4100 kg). Bottom: the 4L bogie with compact brake units acting on thermostable wheels and conventional inboard bearings wheelsets (mass  $\cong$  3700 kg).

It can be observed that the centre bowl has two appendices along the longitudinal axis to react the pitch movement that appears during braking. The new suspension mechanism, in fact, frees one degree of freedom around the lateral axis. This modification is deemed to be small and vehicles can be slightly modified to support the resulting forces.

The interface with the carbody remains the same as that of the Y25 bogie, i.e. it is composed of a centre bowl (or centre pivot) to support the vertical load and two side bearers that support the unbalance of the carbody when running with non-zero cant deficiency/excess (e.g. when standing still on a canted track). The side bearers are

connected to the bogie frame by the supporting frames, described below, with interesting manufacturing and maintenance solutions.

The overall design proves to be extremely efficient in terms of mass and moment of inertia, leading to low material purchasing and manufacturing costs. The key of the design was abandoning the classical architecture with beams subjected to bending and passing to trusses subjected to normal load.

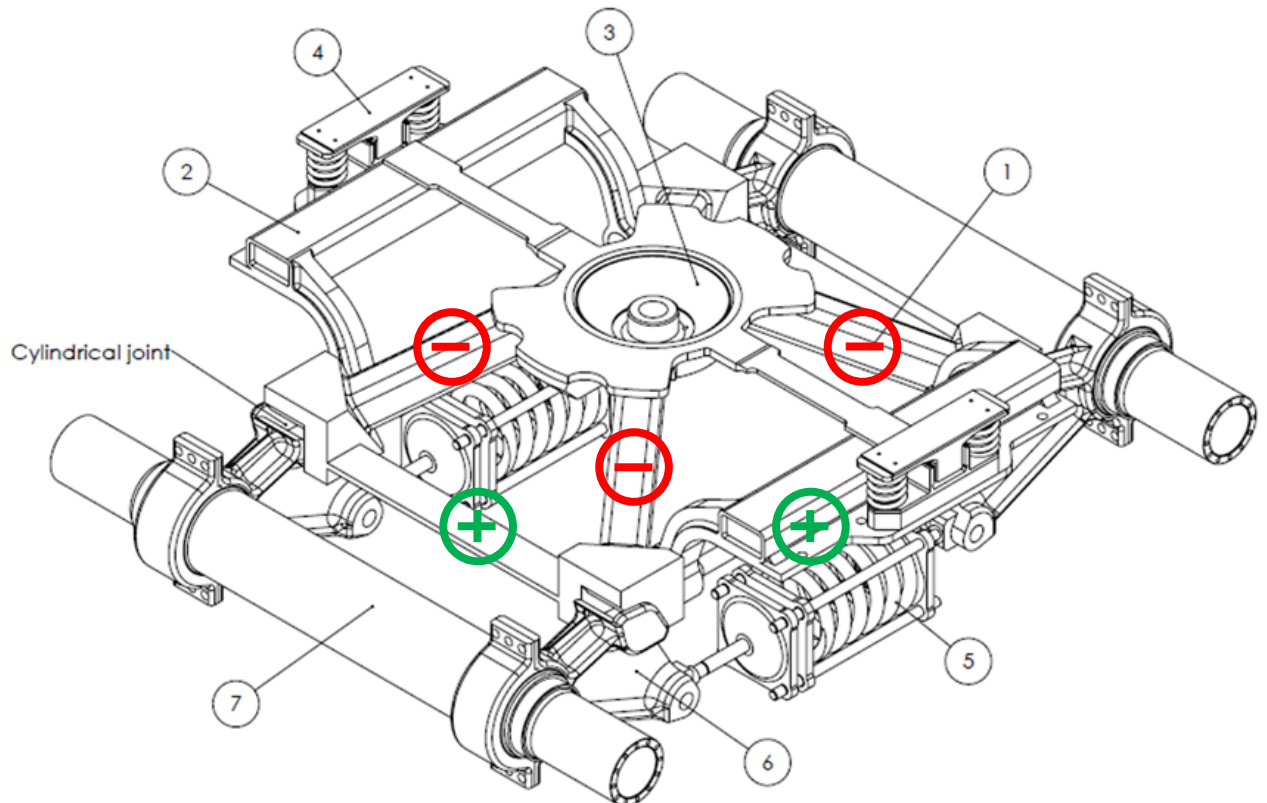

Fig. 7 Main components of the 4L bogie. 1: pyramidal frame; 2: supporting arm for side bearer and brake calipers for wheel web mounted discs (or compact tread braking units); 3: centre bowl; 4: side bearers; 5: horizontal coil springs with single-stage progressive stiffness; 6: swinging arm; 7: Inboard bearings axle. “Legs” are compressed (indicated with “-“), while the basis of the frame is in tension (indicated with “+“)

### 3. DESIGN OF THE 4L BOGIE

While it will be shown afterwards that the 4L bogie exhibits distinct advantages in terms of maximum speed, running dynamics and track friendliness (especially on highly defective track), the main innovation consists in the extremely simple design that results in reduced manufacturing costs and, therefore, aggressive selling prices.

The number of components is reduced, and their role and properties may be summarized as follows:

- the bogie frame is made by mild steel welded parts, of the classical S355 grade, that include standard profiles, with a mass as low as around 320 kg;
- the centre bowl and the “knees” where arms hinge are located can be obtained either by forging or by casting and then welded to the frame, with equally low costs;
- the axlebox arms can be made of cast iron (typically GJS 400 grade) and can either house the bearings (if a standard inboard bearings are used) or clamp the axlebridge in case an AIR Wheelset [6] is used;
- hinges are made of easily replaceable wear-resistant components, and are designed in order to provide a friction damping proportional to axleload;
- the suspension springs are progressive and provide the correct stiffness to keep the vertical (bouncing) frequency of the wagon constant regardless of the axleload;
- the supporting arms, manufactured separately, are bolted to the bogie frame and can be replaced / repaired if needed without scrapping the entire frame.

### **3.1 Description of the 4L bogie frame design and numerical validation**

As any other rigid bogie frame, it is particularly sensitive to track twists. While in the Y25 bogie, as in all the other conventional bogies, twists are managed by differential suspension movements, in the 4L bogie the axlebox arms are connected to the bogie frame with “rigid hinges” that allow rotations while constraining translations. The possibility of surviving the largest possible twists was therefore assigned to frame flexibility. This concept is somewhat similar to other existing conventional bogies equipped with stiff primary suspensions (Figure 8).

Designing a bogie frame strong enough to survive all exceptional and fatigue loads under a 22.5 t/axle load and flexible enough not to fail under exceptional and repeated track twists proved to be extremely challenging and required no less than the evaluation of at least 50 alternatives.

The details of the structural design of the bogie frame cannot be given here for space reasons. As an example, the validation under fatigue loads is shown in Figure 9. It is important to highlight that the structural analysis was possible only after a complete finite element simulation of the entire bogie, as the flexibility of all the components (axlebox arms, springs, wheelsets, etc.) has a large influence on the actual loads imparted on the frame.

A first coarse mesh model was therefore used to find out displacements under all loading combinations; these boundary conditions were therefore inserted in a finer model that allowed to validate the design according to EN 13749 standard. As some welds are not “conventional” joints (“T”, butt, etc.), some joints were validated according to the “advanced” methods (such as the hot spot approach and the effective

notch stress approach) described in the draft standard prEN 17149 (see Figure 10). The development of the design was stopped when the validation phase was passed successfully.

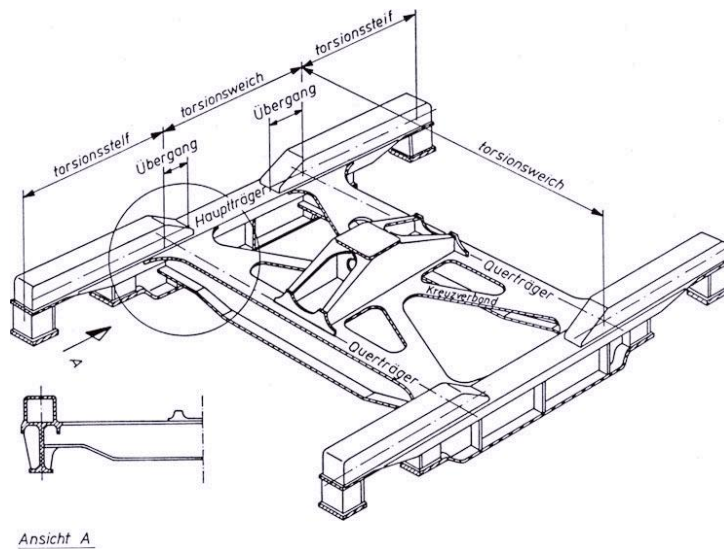

Fig. 8 Example of torsionally soft bogie frame used in bogies with particularly stiff primary suspension (from J. Ihme – Schienenfahrzeugtechnik - Springer Verlag 2016, p. 196)

	Fzp = 392400 N	Fzp = 313920 N Fzb = 78480 N	Fy = 88290 N	Fx = 22072,5 N	dz = 9 mm	Fb = 24615 N Fx = 16187 N	Fi_vert = 5592 N	Fi_lat = 4460 N	Fi_long = 2230 N
J	X (+30%)								
K	X (-30%)								
L	X			X	X				
M	X			X (-)	X				
N	X					X			
O	X					X (-)			
P		X	X		X				
Q		X (opp)	X (-)		X (-)				
R	X								
S		X	X		X				
T	X		X				X	X	X
U	X		X				X (-)	X (-)	X (-)

Fig. 9a Validation under fatigue loads of the frame of the 4L bogie according to EN13749. Load cases.

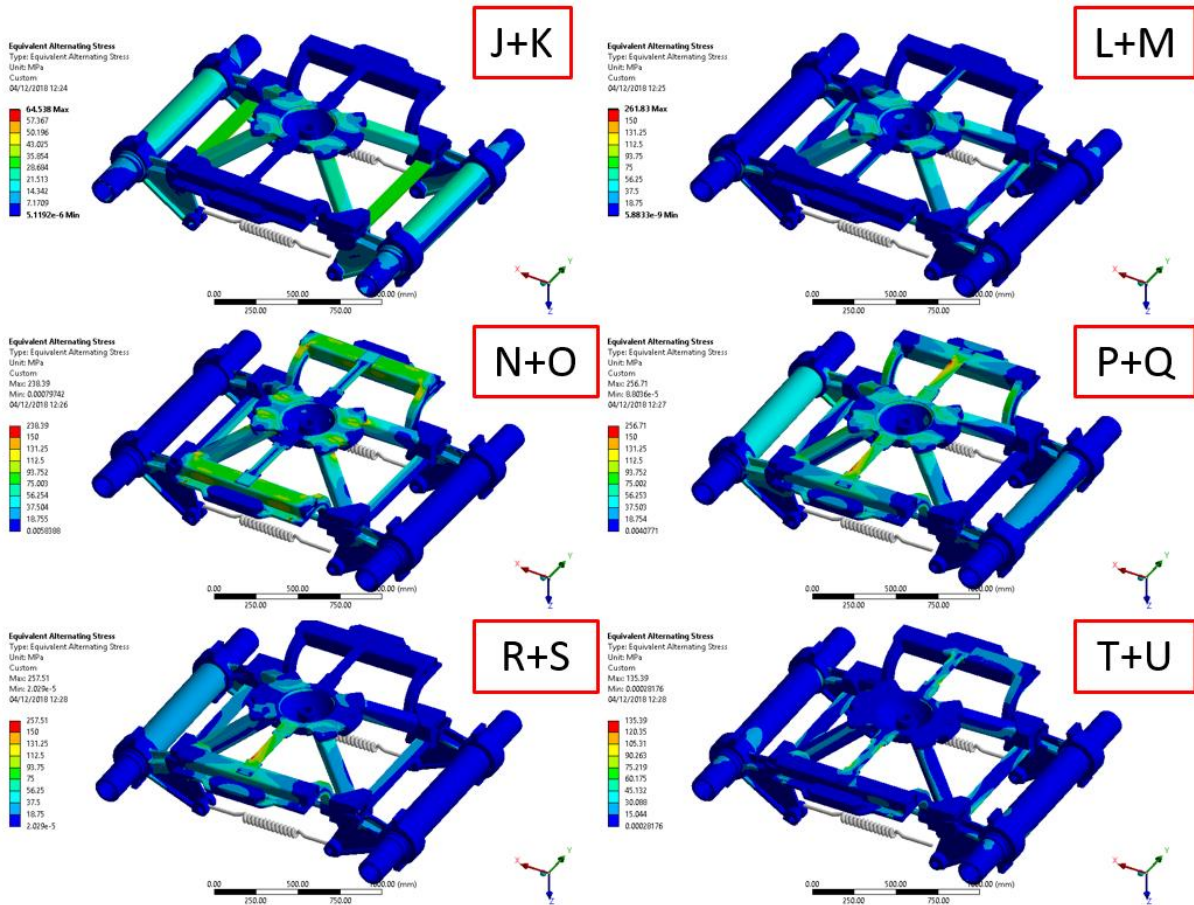

Fig. 9 Validation under fatigue loads of the frame of the 4L bogie according to EN13749. Alternate stress validation. All load cases were successfully validated.

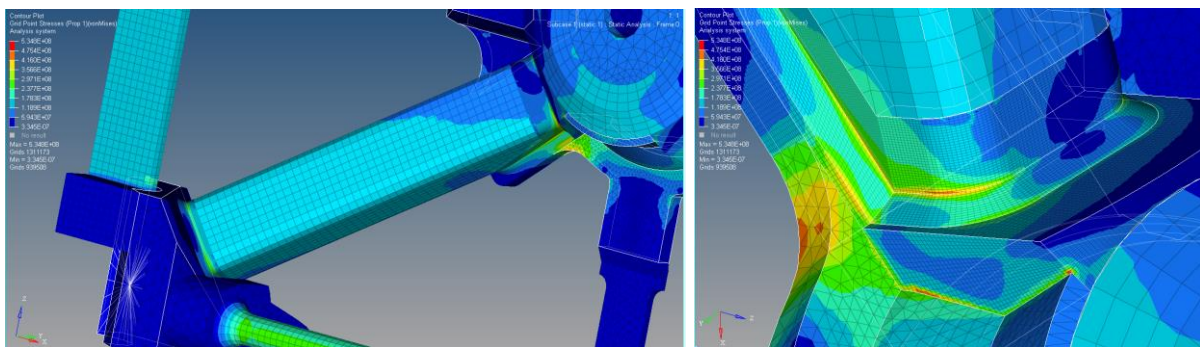

Fig. 10 Validation of the frame of the 4L bogie with the methods described in prEN 17149. Due to the extremely high number of elements, the analysis was applied only locally to weld seams and adjacent areas as specified by the standard.

### 3.2 Suspension elements in the 4L bogie frame

Central in the design of the 4L bogie is the selection of the proper suspension element. Although no details can be given here, Figure 11 shows the non-linear stiffness of the helical springs used (one per side) that replace all the 16 springs on the Y25 bogie. This component provides the correct dynamic response with several

advantages (only one component, easily inspectable, etc.), the most important of which is the absence of the “knee” in the stiffness curve of Y25 bogie due to the intervention of the inner spring at “intermediate” loads with the related uncertainties on dynamic behaviour.

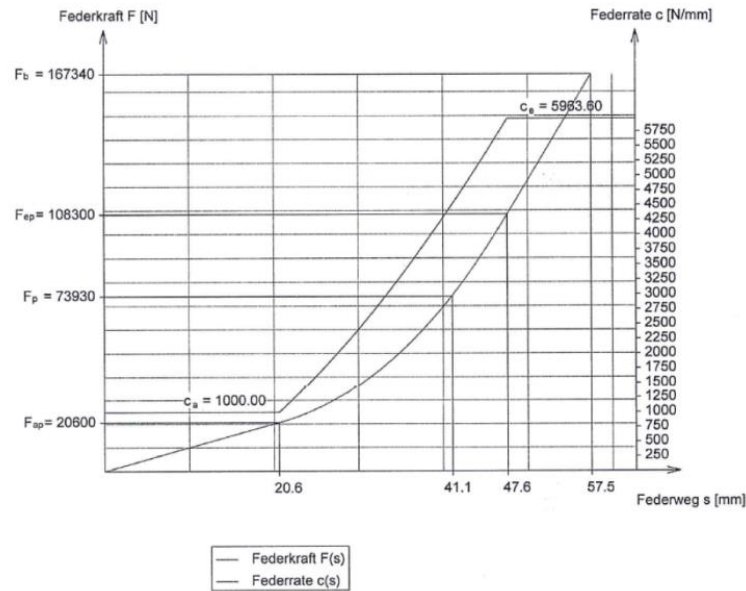

Fig. 11 Stiffness of the progressive spring used in the 4L bogie. Space and mass constraints, particularly stringent, were all satisfied by the contacted supplier.

To better understand the reason why the 4L has an extremely high track friendliness, the concept of the “short circuit” of the two swinging arms needs to be better explained.

In a Y25 bogie, the vertical load  $F_Z$  applied on the centre bowl is shared on the 4 wheels, each with a stiffness  $K_{Y25}$  per axlebox. The resulting vertical displacement is  $\Delta z_{Y25} = (F_Z/4) / K_{Y25}$ . In the 4L bogie (Figure 12a), let suppose for the sake of simplicity that the swinging arm has a geometry such that  $\Delta x = \Delta z$ , i.e. the horizontal elongation of each end of the spring is the same as the vertical displacement of the centre bowl, i.e.  $\Delta x_{4L} = 2 \Delta z_{4L}$ . This results in  $\Delta z_{4L} = \Delta x_{4L}/2 = (F_Z/4) / 2 K_{4L}$ . To ensure the compatibility of the 4L bogie with existing vehicles, must be  $\Delta z_{Y25} = \Delta z_{4L}$ , i.e.  $K_{4L} = K_{Y25}/2$ . The 4L bogie springs were therefore designed to have a stiffness that is a half of the stiffness of Y25 *per axlebox*. This guarantees the same static displacements under the same vertical loads.

This suspension arrangement, that reminds somewhat the Munchen-Kassel bogie, has an interesting behaviour in case short defects are encountered. Let suppose (Figure 12b) that the vehicle finds a local irregularity the forces the first wheelset to lift up with by a quantity  $\Delta z_L$ . If the irregularity is short, i.e. if the bogie frame still did not start to rotate or displace yet, the total elongation of the spring is  $\Delta x_L = \Delta z_L$  but, as long as

the stiffness is  $K_{4L} = K_{Y25}/2$ , this implies that *the vertical stiffness observed during a transient vertical displacement of a wheelset of the 4L bogie is a half of the stiffness of the Y25 axlebox.*

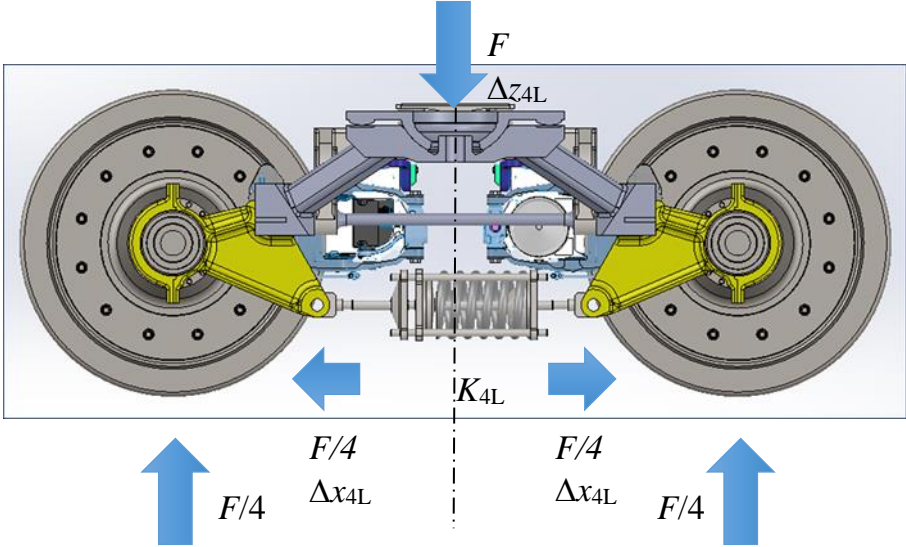

Fig. 12a Calculation of the stiffness of the progressive spring used in the 4L bogie.

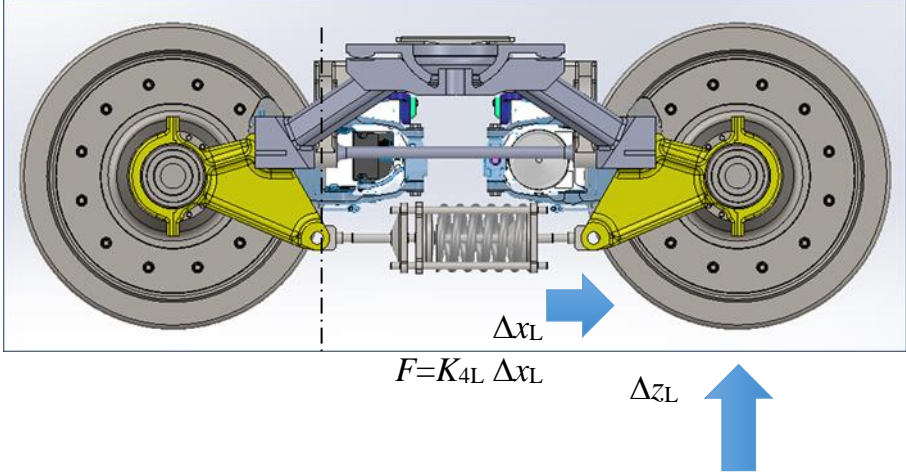

Fig. 12b Calculation of the stiffness seen by a wheelset in presence of a local vertical irregularity.

As an extreme case, consider now that the displacements applied at the wheel-rail contact points are opposite (Figure 12c). In this case the spring does not undergo any elongation. If the displacements are applied harmonically at a sufficiently high frequency, there are in practice no reaction forces on the bogie frame that remain neutral. This explains the exceptionally good behaviour of the 4L bogie in presence of some kinds of irregularities (see the relevant chapter below) that was called “short circuit effect”.

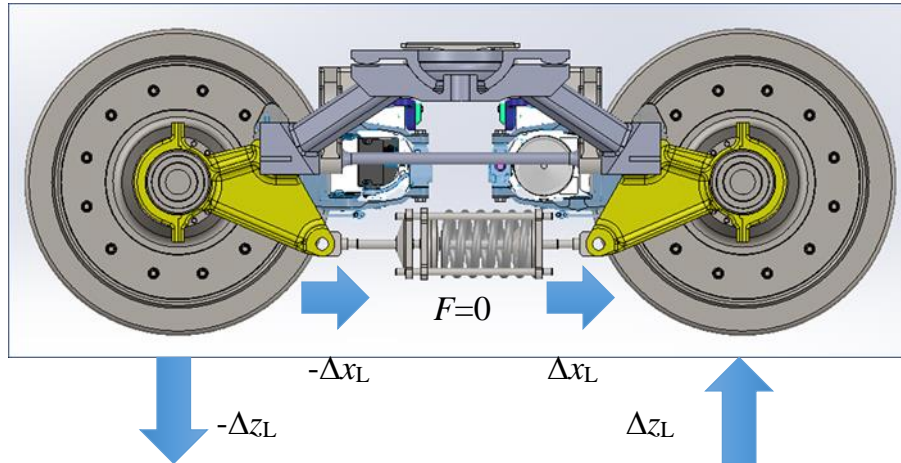

Fig. 12c Counterphase vertical irregularities effect on the 4L bogie.

### 3.3 Friction damping and hinges of the axlebox arms

Rubber elements and hydraulic damping system are not welcome in the freight wagons industry as they may give rise to aging or unexpected and early failures. The Y25 bogie only includes steel and consumable parts (Lenoir link) made of manganese steel. That's why the 4L bogie includes only manganese steel or ADI (Austempered Ductile Iron) consumable components, using the same friction damping mechanism of the Y25.

Long academic discussions could be made about the evident superiority of hydraulic (viscous) damping compared to friction damping, but the lack of success of more sophisticated bogies is indisputably due also to the presence of hydraulic dampers. Figure 13 shows a sketch of the joint, with the two cylindrical (around longitudinal and transversal axes) couplings in evidence. This particular design keeps the reactions inside the bearings of a conventional wheelset to the lowest levels.

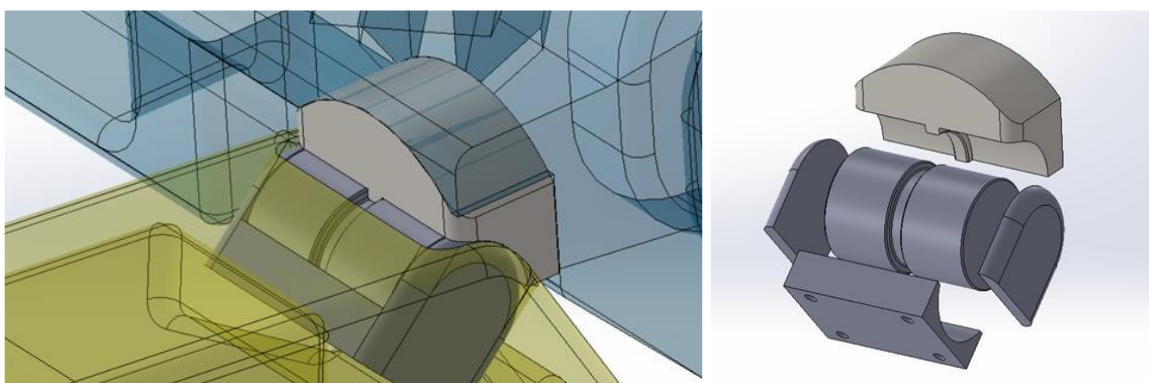

Fig. 13 Left: transparent view of the joint used in the 4L bogie. Right: exploded view of the consumables, made of a few components of low cost.

### **3.4 Axlebox (swinging) arms**

This components do not require a specific description. Their size, shape and stresses are such that they should be casted in spheroidal graphite cast iron (austempered only if needed) and machined accordingly to the common practice. It is nevertheless important to say that as long as no rubber elements (silent blocs) are included in the drawing, tolerances should be strictly respected.

### **3.5 Wheelsets and bearings**

As already mentioned, the 4L bogie can be equipped with conventional inboard bearings wheelsets as well as the AIR Wheelset solution described in [6]. Due to its design, the current architecture of the 4L bogie is not compatible with axle-mounted brake discs, mainly because of the difficulty of housing the callipers. This is not deemed to be a serious drawback of the 4L bogie, as tread-braked thermostable wheels are gaining back the favour of the freight industry and web-mounted brake discs are spread in all the applications.

A final word should be said to discuss the use of inboard bearings, that are a central element to get the astonishing characteristics of the 4L bogie. It is not by chance that all modern bogies use this solution [6], and today, with digital monitoring and “smart vehicle” concepts spreading also into the world of freight wagons, monitoring of inboard bearings is not a problem anymore thanks to advanced and low-power diagnostic on-board devices.

## **4. RUNNING DYNAMICS AND CONTACT MECHANICS OF THE 4L BOGIE**

Running dynamics of Y25 was often criticized because of the intrinsic non-linearity of the suspension (only piecewise linear) and for the presence of friction damping elements. It is a matter of fact, anyway, that the Y25 was extremely successful and that represent the benchmark for any other solution.

While approaching the design of the 4L bogie, several choices were made. First, it was readily acknowledged that the higher speeds, in the order or in excess of 160 km/h, cannot be achieved with a single suspension bogie. Discussing with experts in the freight wagon sector, a top speed of 140 km/h in empty conditions was set as a target. This may look unambitious, but it should be considered that current freight wagon travelling in “SS” regime run at 120 km/h when empty and 100 km/h when loaded.

The selection of this target speed was in line with the locomotives available for freight trains (e.g. some locomotives of the TRAXX family by Bombardier have a maximum speed of 140 km/h, allowing a relevant simplification in the drive chain) and seems well suited for the distances and traffic on conventional routes

The validation of the 4L bogie from the running dynamics point of view was therefore performed, according to the prescription of the EN 14363 standard, by using the multi-body code VI-Rail. Only some information extracted from paper [4], to which the reader is referred, will be shown in the following.

### 4.1 Lateral dynamics (stability)

Lateral dynamics simulation results are shown in Figure 14. Stability limits on straight track with “high level” track defects are reached for a speed of about 145 km/h for the empty wagon and for a speed of 180 km/h for the laden wagon. This means that the 140 km/h target is achieved.

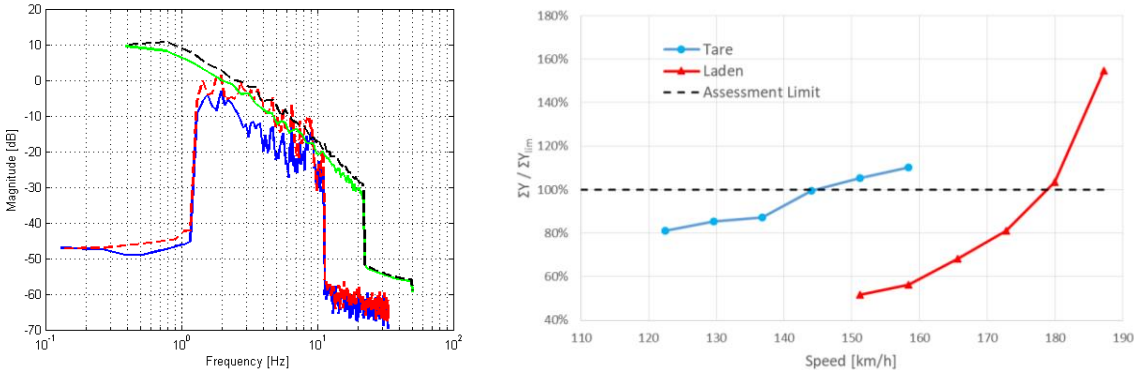

Fig. 14 Left: PSD distribution of lateral (alignment, solid blue) and vertical (longitudinal level, dashed red) for measured defects and the corresponding EN 14363 “High Level” irregularities lateral (solid green) and vertical (dashed black). Right: stability assessment according to EN 14363 in tare and laden conditions for the 4L bogie (from [4]).

### 4.2 Vertical damage and track access charges

The implication on track access charges in the UK according to the *Ride Force Count* method allowed to find the *Suspension Discount Factor*. The dynamics of 4L bogie and Y25 bogie was compared, showing that the average dynamic vertical force per unit of axle load are low for the new bogie even at higher speeds (Figure 15).

Vehicle		Mean value (tare)	Mean value (laden)
Y25 (120 km/h)		0.238	0.102
4L bogie	120 km/h	0.127	0.052
	145 km/h	0.162	0.072
	160 km/h	-	0.085

Fig. 15 Vertical force average dynamic component of Y25 and 4L bogies in different loading conditions (adapted from [4])

### 4.3 Running through curves – wheel and rail wear and RCF

A specific attention was devoted to the identification of the 4L bogie behaviour in curves. It is known, in fact, that the Y25 bogie has poor steering performances and one of the goals was to get  $T\gamma$  values as low as possible.  $T\gamma$ , the wear number, is directly related to rail wear and crack growth, as shown in Figure 16.

Due to the roll angle of the wagon and the increase of the load of the external wheels, the suspension arrangement of the new bogie generates a better steering performance as it allows the wheelset to align radially when the vehicle runs with  $h_d > 0$  ( $a_{nc} > 0$ ). In such case the external suspension arms rotate more than the internal ones, generating an outer wheelbase greater than the inner one. For  $h_d = 92$  mm ( $a_{nc} = 0.6$  m/s<sup>2</sup>), typical for freight trains,  $T\gamma$  rapidly drops to zero, generating virtually no damage in the rails (Figure 9).

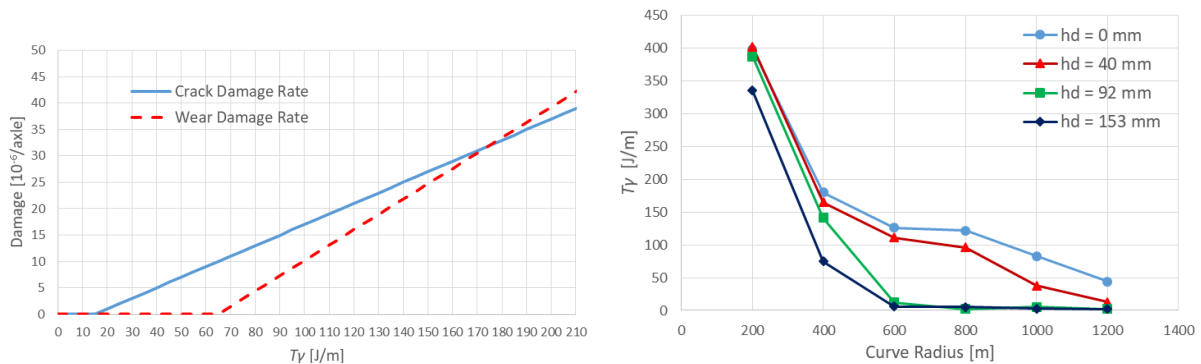

Fig. 16 Damage given by single axle (left).  $T\gamma$  of the front axle a leading 4L bogie for different curve radii and cant deficiencies in laden condition (adapted from [4], right).

### 4.4 Safety against derailment

Derailment coefficient was evaluated considering method 2 of EN 14363, measuring the lateral force of the outer wheel on flat track with radius  $R=150$  m and no transition and the minimum vertical force due to a twist of 0.42% applied during static tests [5].

Both 4L and Y25 bogies showed a maximum derailment ratio lower than the safety limit of 1.2 (1.06 for the Y25 and 1.01 for the 4L), obviously in empty conditions. Figure 17 shows the lateral forces of the outer leading wheels of the two bogies in empty conditions. While the stationary value for the Y25 is about 15 kN, the peak value at the beginning of the curve is almost double and it is higher than the 4L for about 20 m.

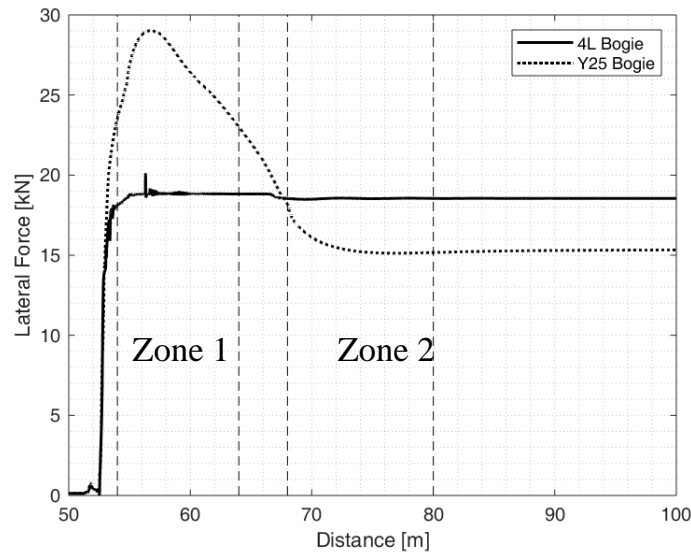

Fig. 17 Lateral force of outer leading wheel of both bogies in empty conditions. According to EN14363, the track is divided in zone 1 (only the first bogie is entered in the curve) and zone 2 (both bogies are entered in the curve).

#### 4.5 Response to harmonic and isolated longitudinal level defects

Vertical track irregularities are usually statistically distributed as shown above. To highlight the superiority of the 4L suspension architecture, numerical tests were arranged with longitudinal level defect harmonically distributed from 1.2 m to 3.6 m, including 1.8 m (the wheelbase of both Y25 and 4L bogies).

When the harmonic defect moves the two wheels in counterphase, the “short-circuit effect” exists as expected and leads to dynamic contact forces very similar to the static ones (Figure 18). A direct comparison of the response to harmonic defects of the two investigated bogies show the superiority of 4L vs Y25. In the worst case, in fact, the 4L bogies exhibits vertical forces 25% lower than the Y25, while in the best cases this reduction reaches even 80%.

The behaviour in presence of isolated level defects was investigated by exciting the vehicle with a defect with spectral content up to 20 Hz [5]. While the response at the wheel-rail contact is only slightly lower for 4L compared to Y25 (depending mainly on *PI* force which depends on the mass of the wheelset, that in practice is the same for the two bogies), the acceleration (and therefore the inertia forces) on the centre bowl are much lower for the 4L bogie compared to Y25 bogie (Figure 19).

The forces on the centre bowl were then investigate in three different conditions: empty, partially laden and fully laden (respectively 5.5, 11 and 22.5 t/axle). The difference between the peak dynamic forces increases with the static load, as shown in

Figure 20, resulting in a beneficial effect of the suspension, highlighting the superiority of 4L bogie when isolated defects are encountered.

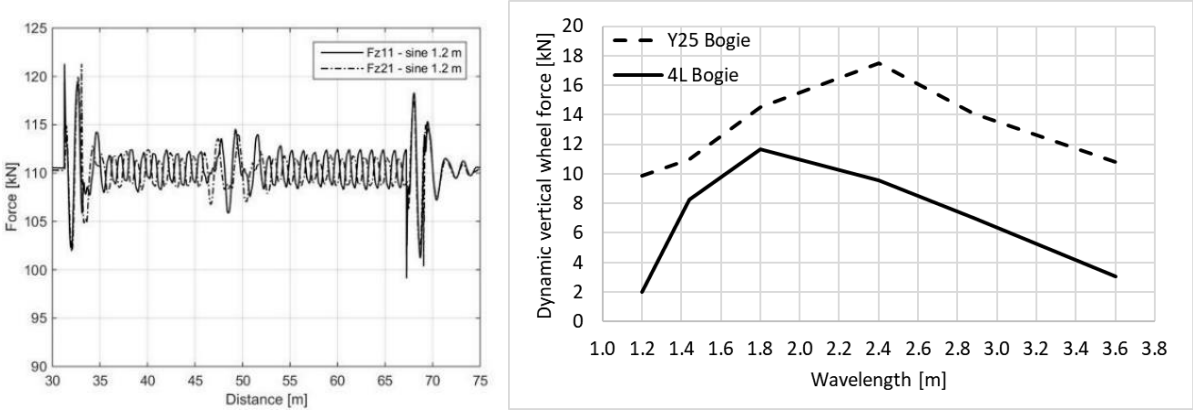

Fig. 18 Left: “short-circuit effect” of the 4L bogie for the 1.2 m wavelength case in laden condition. Right: comparison of dynamic vertical force for 4L and Y25 bogies as a function of longitudinal level harmonic defect wavelength in laden condition.

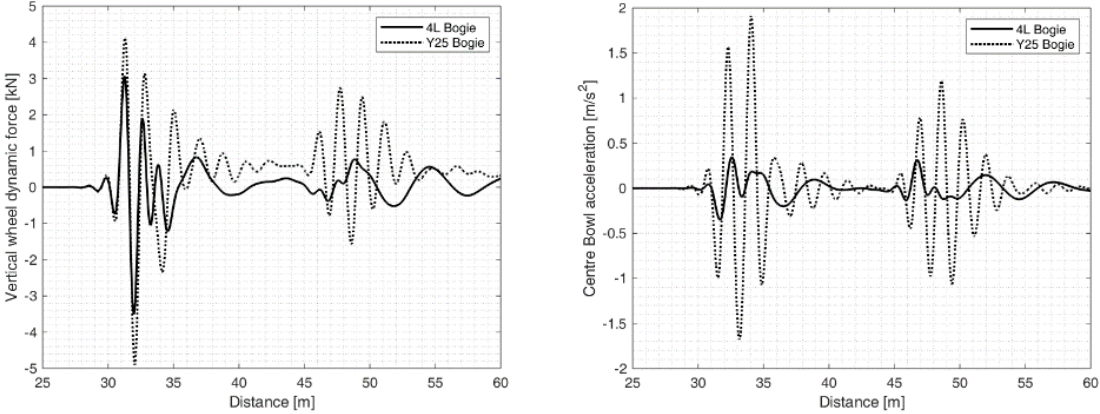

Fig. 19 Left: Vertical wheel-rail dynamic force. Right: Centre bowl acceleration. Signals are shown for the empty case.

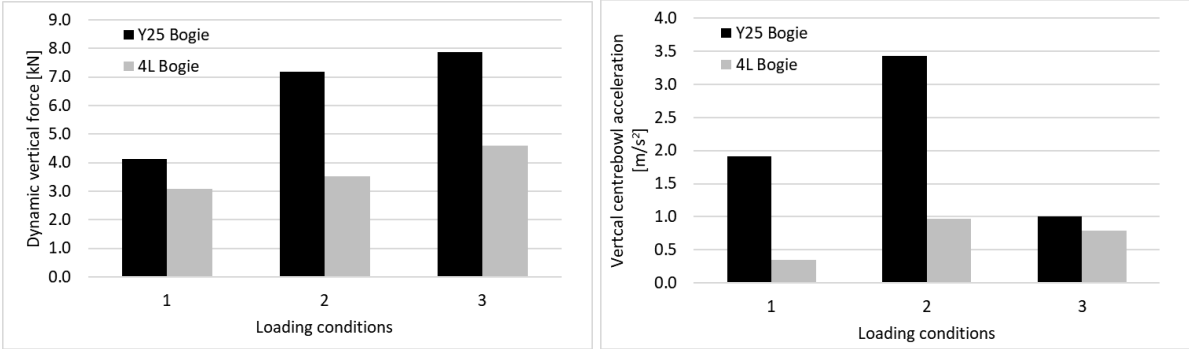

Figure 20. Dynamic vertical force (left) and vertical centre bowl acceleration (right) in empty condition (1), partially laden condition (2), fully laden condition (3).

### 4.6 Running behaviour on switches and crossings

The running dynamics behaviour on S&C is a particularly complex subject that requires specific skills and experience to be correctly simulated. Figure 21 compares the behaviour of Y25 and 4L bogies when running on a switch in the through direction. It can be seen that the dynamic force generated by the 4L bogie is almost negligible when compared to that of the Y25 bogie.

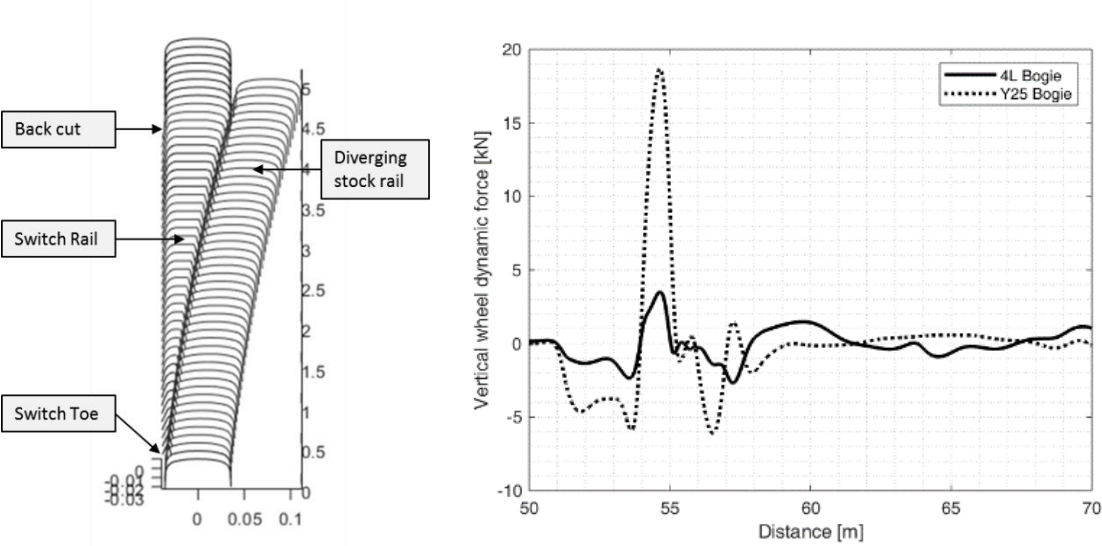

Figure 21. Comparison of the vertical dynamic forces in the laden case at 80 km/h in the through direction.

The evaluation was performed for the aforementioned three load cases, obtaining the results shown in Figure 16. For all the cases the vertical impact force given by the 4L bogie is only a fraction of the one given by the Y25.

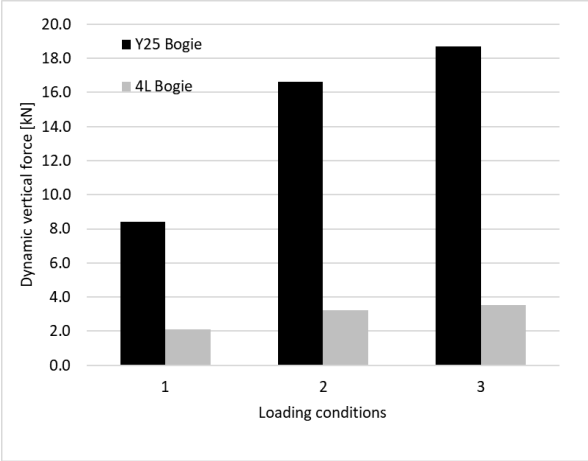

Figure 22. Vertical dynamic peak force in empty condition (1), partially laden condition (2), fully laden condition (3). Speed = 80 km/h in the through direction.

The behaviour in the diverging direction is fundamental to forecast switch blades wear. An excerpt from [5] says:

The results in terms of wear number must be discussed according to the considered zone of the switch. The initial peak value at switch toe is practically the same for both bogies for the leading wheel, while the rear wheel of 4L bogie initially increases more rapidly than the Y25's but quickly comes back down. While negotiating the diverging part of the switch, the Y25 shows a large increase of the wear number covering almost the entire lead length between toe and crossing nose. Significant wear will ensue, which is not the case for the 4L bogie. Beyond the lead length, the stationary value is about the same for both bogies but the mean value (calculated as the area under the wear number curve divided for the length of the curved part of the switch) is always favourable for the new bogie. In conclusion the new bogie would impose far less wear than current freight bogies in the initial transition areas of switch panels, where severe wear leads to increased maintenance and early switch rail replacement.

This confirms the huge superiority of the Y25 also in the negotiation of switches in the diverging direction (Figure 23).

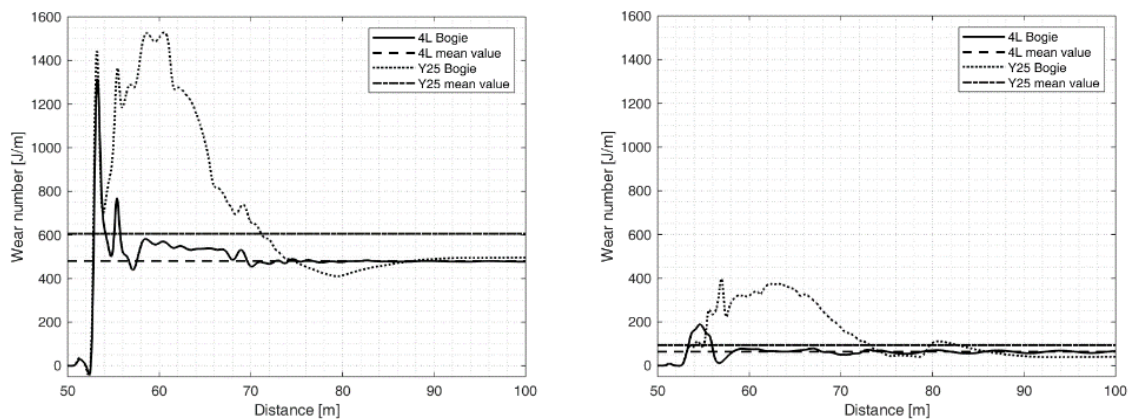

Figure 23. Comparison of wear numbers on the switch blade in the diverging direction for the front wheel (left) and the rear wheel (right) of 4L and Y25 bogies.

## 5. CONCLUSIONS

In this paper the innovative 4L bogie is described with special attention to manufacturing costs. Adopted solutions are simple and easily maintainable.

Structural issues were addressed rigorously and the straightforward applicability of the 4L bogie concept is ensured. Improvements on running dynamics and track friendliness are enormous, leading to a very low-cost and extremely track friendly bogie.

As the estimated cost of the frame is 20÷30 % lower than the Y25, the impact on the market could be relevant. Implementation times look short as all the main tasks were addressed and the bogie frame can be considered “virtually homologated” having passed all the phases requested by international standards.

## 6. REFERENCES

- [1] **CSIBA, J.:** Bogie Type Anniversary: the Bogie Type Y25 is over 50 Years. Proc. of the 10TH International Conference On Railway Bogies And Running Gears, Budapest, Hungary, 12 - 15 September, 2016 (pp. 253-262)
- [2] **SUSTRAIL Project.** Concluding Technical Report, available at [www.sustrail.eu/IMG/pdf/sustrail\\_final\\_book\\_web.pdf](http://www.sustrail.eu/IMG/pdf/sustrail_final_book_web.pdf) (accessed 21.03.2019)
- [3] **5L Project.** White Paper Innovative Rail Freight Wagon 2030, available at <https://www.schiene-fzg.tu-berlin.de> (accessed 21.03.2019).
- [4] **Bracciali A., Megna G.:** Track friendliness of an innovative freight bogie, In: Li Z., Nunez A. (eds.), 11th International Conference on Contact Mechanics and Wear of Rail/Wheel Systems (CM 2018), pp. 81-89, Delft, The Netherlands, September 24-27, 2018
- [5] **Megna G., Magalhaes H., Bezin Y. and Bracciali A.:** Running dynamics and contact mechanics comparison of two freight bogies running in plain line and through switches and crossings, Proc. of the 26th IAVSD Symposium on Dynamics of Vehicles on Roads and Tracks, Gothenburg, Sweden, from 12-16 August 2019.
- [6] **Bracciali A., Megna G.:** Inside Frame Bogies & Air Wheelset A Winning Marriage. In: 10th International Conference on Railway Bogies and Running Gears, Budapest, Hungary, 12-15 September 2016.