

3D SURVEY OF THE HOLY SEPULCHRE USING MODERN GEOMATIC TECHNIQUES

Grazia Tucci
Valentina Bonora

Introduction

The work illustrated hereafter was undertaken in response to a request from the religious Communities entrusted with the Custody of the Church of the Holy Sepulchre for an assessment of the seismic risk to which this extraordinary architectural complex is exposed. The initiative also attests to the willingness of the Greek Orthodox, Franciscan and Armenian Communities to participate in a common project for a better understanding and preservation of the monument.

It is with this dual aim – of *structural analysis* on one hand, and *documentation* for the study and safeguarding of the monument on the other – that this three-dimensional survey of the whole complex was carried out.

In particular, a morphometric description is an essential preliminary element for the correct interpretation of structural behaviour when analysing the seismic vulnerability of monumental buildings.

The indispensable precondition for effective

research is the *reliability* and *completeness* of the data pertaining to the monument and this is one of the reasons why the most innovative methodologies and tools were used to metrically document the actual state of the architectural complex: GPS, total stations, three-dimensional scans and photogrammetry were combined to create an authentic “*integrated metric survey*”.

2.2.1. Previous survey and archaeological studies

Even if we disregard the epitomised and almost symbolic depictions produced by pilgrims since the fourth-fifth centuries, this is by no means the first 3D and high resolution survey that has been performed on the whole complex. In this connection, suffice it to recall first of all that of Bernardino D’Amico [AMICO, 1997], complete with measurements and in its own way iconographically effective; the patient work of analysis and interpretation by Father Corbo [CORBO, 1982]; the meticulous photogrammetric survey by Martin Biddle

for the *Aedicula* [COOPER, 1994; BIDDLE, 2000; see chap. 1/5]; as well as the admirable photogrammetric survey of the whole structure carried out in more recent years by a team of Greek colleagues [BALODIMOS & AL., 2003] described in the previous chapter.

As a result, our group took up a tricky challenge: what further contribution could be given with the aid of the new technologies now available? In the last decade, the laser scanner has proved to be a powerful three-dimensional metric survey tool which has

notably expanded the possibilities of understanding historic monuments.

The third dimension, which enables us to represent ideas and projects, test out our hypotheses and describe and communicate the state of buildings, that third dimension which has always inspired the models of the main structures in the Holy Land, is now, at last, a reliable piece of data available to the scholar.

Therefore, by applying these digital and three-dimensional survey systems we have filed documentation that is as complete as



FIGURE 2 View of the Chapel of St. Helena.



FIGURE 3 Chapel of St. Helena. Point model. All the furnishings and lamps acquired can be seen.

DIMENSIONS OF THE BLOCK	about 140 m (from the Christian Road to Souq Khan el-Zeit) x 110 m (from St. Helena's Road to the Via Dolorosa).
DIMENSIONS OF THE MAIN BUILDING	about 120 m x 70 m
MAX. DIFFERENCE IN HEIGHT IN THE CHURCH	about 51 m (from the bottom of the quarry under the Chapel of St. Helena to the top of the cross on the Anastasis dome)
SURVEYED AREA AT GROUND FLOOR	about 4,500 m ²
SURVEYED AREA AT ROOF LEVEL	about 6,800 m ²

TABLE 1 Summary of the Surveyed Area.

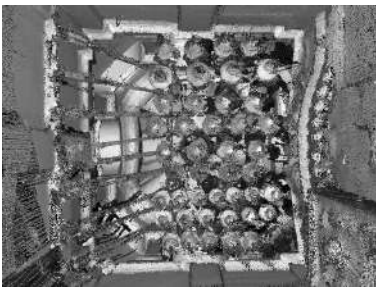

FIGURES 4 AND 5 The 3D scan of the Sepulchre chamber vault shows some holes in the data due to the hanging oil lamps.

possible on the current state of the monumental complex of the Holy Sepulchre.

The laser scanner detects all the surfaces that are visible from the instrumental position: therefore, not just walls, columns, capitals, but also lamps, candelabra and even pilgrims. And for this very reason a large part of the work was performed during the night. This made the work a highly fascinating and emotionally involving experience.

The data is so dense that if one is to observe the model from further away, it appears to form a continual surface, but upon moving closer, the true structure appears from the acquired data and the single points which constitute the 3D model become recognizable.

Father Piccirillo has studied models of the Holy Sepulchre for a long time [PICCIRILLO,

2007]; perhaps this is also why he has grasped the potential of this new method of producing documentation and understanding the 'model', which is still three-dimensional but is now virtual (because it is numerical) and objective (as it is not the result of an interpretation). Each of the millions of points making up the model has its spatial coordinates within a single reference system. Therefore, we can look to this immensely rich geometric database to find distances, height differences, check alignments and investigate relations between spaces that are not directly connected.

The function of the topographic measurements, which were made inside and outside the monumental complex, is to create a common framework for the whole survey, the topographic control network in which to express all the measurements – all in all over 3 billion points – even if they were made in different survey campaigns, in different settings and even using different instruments.

The overall model is a database that we can consider the virtual memory of the monument, available for remote consultation in space and time.

It is important to underline that this study would not have been possible without the willingness, trust and cooperation of all the religious Communities



FIGURES 6-9 When observed from a distance the point model seems to reconstruct the continuity of the surfaces under survey, whereas on closer observation one can see the discrete nature of the survey data.

in the monumental complex of the Holy Sepulchre. The *Status Quo* and intense frequentation of the church by large groups of pilgrims make many places difficult to access. We were permitted access to all the spaces and to stay in the church during closing hours. The time spent inside the church in the company of the religious persons who live in these places day in day out was of great help to us in understanding the surveyed structures. The rich layers of history, the complex layout of the spaces and the fragmentation deriving from the *Status Quo* make it difficult to understand the architectural complex. Each time the help of the single persons belonging to the different Communities was a precious guide in carrying out the work.

Hegumen Daniele himself claimed that he had received a great deal of help from those who knew the places as they had always lived there: «so this cave was the Lord's tomb as I described it after studying it closely alongside those who have been here for some time and know the holy places» [See *Itinéraires russes en Orient*, trad. D. DE KITROWO, in "*Société de l'Orient latin*", Sér. Géogr., t, V, Genève 1889].

2.2.1.1. The 'integrated metric survey' for structural analyses

The main objective of the integrated metric survey performed at the monumental complex of the Holy Sepulchre was to extract metric and qualitative information in order to define the models used in the structural studies.

The survey produces a three-dimensional points model which describes the consistency of the object under investigation in the most detailed manner possible. As is the case for all surveys, it is not just the recording of a transitory phase in the history of the structures under investigation (the contemporary period), but it also

documents the current method of analysis, the techniques adopted and it itself becomes a moment in the history of the representation of the Holy Sepulchre.

Today the information can be shared, also in real time, thanks to the digital nature of the data and the diffusion of the Internet. As a result, there are many different ways of communication and scientific exchange, suitably enabling the interdisciplinary approach required by a meticulous and complex study such as that on the monumental complex of the Holy Sepulchre.

First, the seismic vulnerability analysis required a geometric description of the whole architectural complex; thanks to the measurement techniques adopted we were able to produce a three-dimensional model from which to extract, also at a later date, sections and the relative orthogonal images in numbers and from directions which do not necessarily have to be defined beforehand.

Starting from the same 3D database, both architectural drawings and detailed models for structural analysis were extracted. The most innovative element is that these study phases were carried out at the same time: once the data had been acquired in situ, we had a flexible investigation tool since, starting from the entire model, it is possible to quickly and flexibly extract the necessary sections without the restrictions imposed by a traditional approach. Indeed, as is known, typical documentation consisting of plans and vertical sections can guarantee the accuracy required for subsequent studies, but it is unlikely to ensure a truly exhaustive description; these depictions are always limited to planes, which are singled out in terms of lies and significant trends, having been defined beforehand in the measurement phase.

FIGURES 10-13 Chapel of St. Helena. Definition of the section planes on the point model.

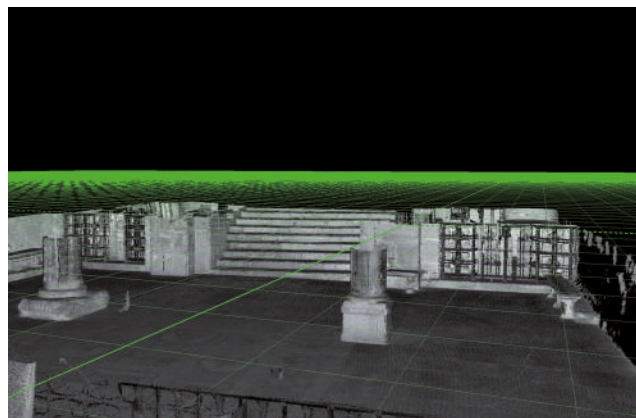
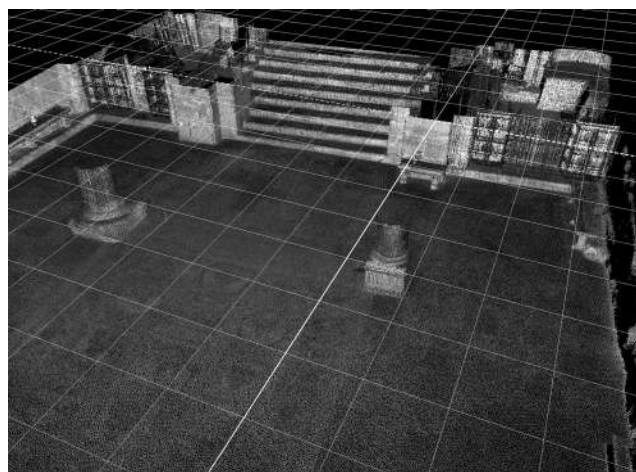

2.2.2. Survey instruments and methods

The diffusion of digital technologies has produced a significant change in the manners of recording spatial data which, by heading increasingly in the direction of growing automation, has fed the illusion that we can now create a model with no limits to its capacity. Among the innovations that have recently contributed to this change of scenario, above all we need to point out the spreading appearance of scanning systems alongside more consolidated methods such as topography and photogrammetry.

Thanks to these instruments and the level of automatism that they have achieved, it is quick and easy to define the position of a large number of points. The understandable emphasis set upon such a promising instrument must not, however, lead to banal syllogisms just because it is so simple to acquire spatial data. This 'new' process of understanding architecture must be based on a rigorous metric approach in which the concept of accuracy is still fundamental. This, along with the scale and detail of the graphical products that one intends to obtain, must still be commensurate with the aims of the survey in the inevitable planning phase.

Metric survey is still a fundamental step for documentation: consisting of a rational discretization of the spatial continuum, it remains a formidable instrument for describing architecture. Indeed, some refer-

ences need to be made to the traditional concepts of surveys and of measurements more in general: the first to regain the critical intelligence that is indispensable in order to transform a banal 'sampling' of the object into a model capable of giving a valid summary of it, and the second to respond to the new analysis and data processing requirements. Since in general no single survey technique can be considered self-sufficient, as a consequence what is needed is a correct integrated use of all the metric survey techniques.

By integrating different measurement methods and techniques we were able to produce the information needed for the structural study. The database is the starting point from which to extract all the information useful for documenting the monumental complex of the Holy Sepulchre: raster (rectified images and orthophotos) and vector drawings (two-dimensional representations and three-dimensional models).

In particular, the survey was tackled by integrating topographic, photogrammetric and laser scanning systems. Thus geometric and photographic information can compensate each other: the first is obtained from the detailed topographic survey and 3D scans, with geometric modelling of the investigated spaces, the second obtained by orthographically projecting high-resolution images onto the previously defined model.

2.2.2.1. Work plan

The speed of acquisition of the instruments employed reduced the work period in situ to a few weeks, organized into three successive campaigns between 2007 and the end of 2008: the first campaign took place from 16 April to 30 April 2007, the second from 24 January to 8 February 2008, and the third from 19 November to 12 December 2008.

It was chosen to begin the space analysis in the *Anastasis*, to then progressively proceed towards the outside of the structure, finally documenting the relationship of the building with the bedrock on which it is founded and which emerges in several places. The deeper knowledge of the bedrock morphology has fostered the advancement in the historical studies on the original conformation of the Holy Sepulchre as presented by S. Fiamminghi in chapter 1|3 of the present volume.

To complete the metric acquisition phase, photogrammetric images were taken as well as thorough photographic documentation. At the end of the work, the graphical output produced was checked on the field, between 10 March and 16 March 2009.

2.2.2.2. Instruments

Two different scanning systems were used in the three survey campaigns (HDS 3000 and HDS 6000, Leica Geosystems), as well as two total stations, a pair of GPS antennae and receivers, calibrated and uncalibrated cameras, portable computers and relative accessories. The different technical characteristics of the scanners used are summed up in the table at left.



FIGURES 14 AND 15 3D scanners used for the metric survey of the monumental complex of the Holy Sepulchre: HDS3000 3D scanner and HDS6000 3D scanner (Leica geosystems).

HDS3000 - (2007 CAMPAIGN)	HDS6000 - (2008 CAMPAIGNS)
Instrument Weight : 17 kg	Instrument Weight : 14 kg
Power Supply Unit Weight: 12 kg	Power Supply: integrated batteries
Controlled by: PC with specific sw and minimum required components	Controlled by: NetPC, by browser
Scan Rate: about 1000 pts/sec	Scan Rate: about 500,000 pts/sec
Position accuracy: 6mm @ 1m-50m	Position accuracy: 6mm @ 1m-25m; 10mm @ 50m

TABLE 2 Technical specifications of the laser scanners.

2.2.2.3. How 3D scanning systems work

The scanning systems work by actively using a laser beam to measure distances both with the pulse method (measuring the wave's time of flight) and the phase method (measuring the phase shift between the emitted and the reflected waves). A rotating mirror deviates the laser beam in space: by knowing the spatial orientation of the laser beam direction as well as the distance measured along that direction, it is possible to calculate the spatial coordinates of the point.

In terrestrial applications, on one hand laser scanning systems greatly simplify the instruments needed, but on the other they require more care in processing the obtained data. A 3D scanner can be defined as a tool able to automatically record the three-dimensional coordinates of points regularly distributed on a portion of an object's surface, at high density [BÖHLER, 2004]. Range scanners work in a similar way to a total station: both calculate the position of a point in space using its polar coordinates (an angle on the horizontal plane, an angle on the vertical plane and a slope distance), which are subsequently transformed into Cartesian coordinates. The substantial difference is that in the case of a total station, the point measured is collimated, and therefore 'chosen' beforehand by the operator, while the scanner samples the space in a dense but non-critical manner.

With laser scanning systems, it is possible to quickly and automatically gather large quantities of data which until recently were unimaginable. As a result, the acquisition times can be limited while producing a complete and detailed description of the object under investigation. The instruments used on average acquire till 500,000 points per second; the time needed for a scan depends on the scan

resolution and varies from 3 to 10 minutes. A single scan therefore produces from 11 million to 30 million points. The adopted settings enable a description of the surveyed surfaces with around one point per square centimetre.

On the other hand, the data obtained requires greater care during processing and great calculating capacity. The time needed for the subsequent processing varies greatly depending on the results that one wishes to produce and it is closely related to processing power. In a few years, the computing power of PCs has grown enormously, so that today a project like this could be managed differently. In our more recent experiences in fact, it was possible to process more massive 3D models without any sub-projects arrangement, as it was indispensable for the Holy Sepulchre, described as follows.

In addition to their precision, laser scanners also stand out for their range, namely the maximum distance they can measure, which to a large extent depends on the strength of the signal emitted and the nature of the surveyed surface.

2.2.2.4. Acquisition

The geometry of the recordings and the scanner resolution was planned each time depending on the shape and dimension of the spaces under investigation. When estimating the acquisition times, it is important to remember not to consider only the scanning time, but also the time is needed to actually move around and set up the sensor. In architectural applications, at times the greatest restriction is not only the far range limit, but also the closest one as in the case of the *Aedicula* (Figures 17-18). In range scanners, the acquisition geometry can generally be traced back to a central projection, therefore, the aspects to consider for acquiring a satisfactory range map are similar to those for taking a good

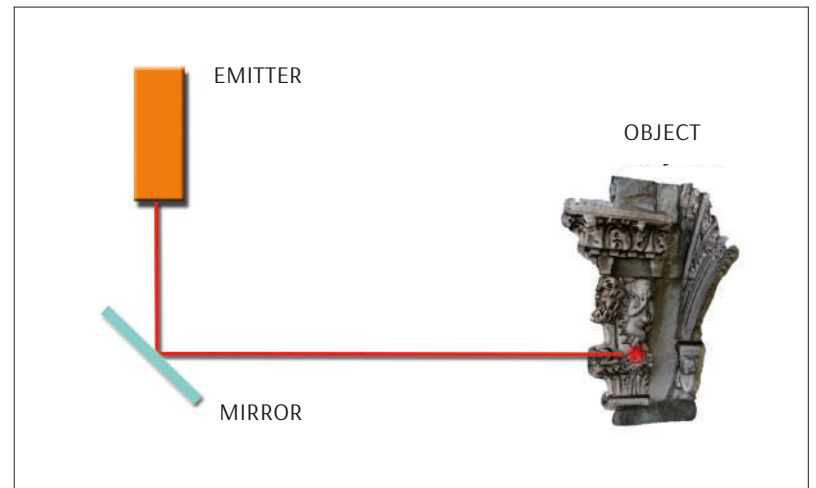

FIGURE 16 Figure showing the operating principle of a range scanner.

FIGURES 17 AND 18 Scanning inside the *Aedicula* of the Holy Sepulchre: the scanner set up is not easy due to the small space.



photograph. As in every photographic campaign that intends to give thorough documentation of complex spaces, it is generally necessary to make several acquisitions, from different viewpoints. First of all, this means that data not visible from one scan position have to be recorded from another scan position. Furthermore, it is necessary to consider that optimal measurements require orthogonality: scans taken from non orthogonal position enable the acquisition of much wider surfaces, but the data obtained is of a lower quality (due to less energy of the signal reflected from grazed surfaces, a bigger spot size for more distant areas, and non-uniform resolution of the range map).



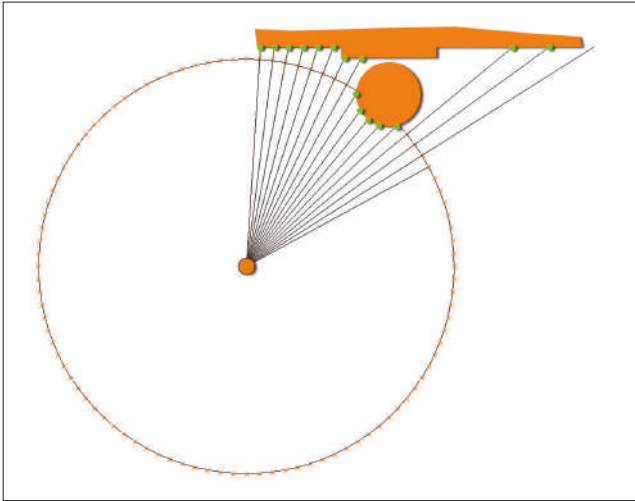

FIGURE 19 The points surveyed with each scan are equidistant from a spherical surface concentric to the instrument. The image illustrates the points' distribution on the surface of an object and highlights the presence of holes (that is, lack of data) owing to jutting elements which cause areas of 'shadow' with respect to the instrument centre.

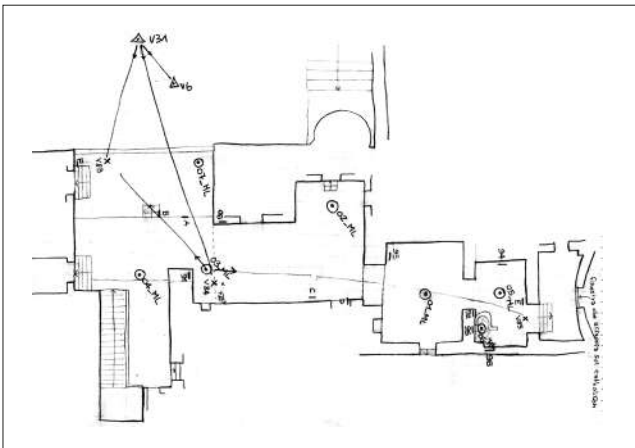

FIGURE 20 The recording project is made in the field, each time assessing the conformation of the spaces to investigate, and is noted down in the survey diary.

Despite the rapid introduction of automatism during the measurement phase, the necessity is therefore confirmed to draw up a preparatory sketch showing the schematic configuration of the area under analysis, the various locations of the scanners, the extension of the single acquisitions on the object, the position, the type and the name of the targets.

As far as the actual scanning phase is concerned, furthermore, it is important (and useful in the subsequent recording phase) to note down information such as the name of each scan, its resolution and duration, as well as the number and name of the targets recorded (metadata).

Owing to necessities intrinsic to the subsequent data processing phase, there must always be a sufficient degree of overlap between close range maps; the overlapping areas can vary, depending on the morphology of the common area. Obviously, for a complete documentation, depending on the size of the object under examination, acquisitions must not just be made from the ground level only, but possibly at different heights, compatibly with the great difficulty in handling the scanning systems and the stability needed in order to correctly make the measurements. It is evident that, lastly, when planning the scan positions, the characteristics of the scanner need to be taken into consideration (for example, the optimal distance from the surface for recording) as well as the ability to move around in the space surrounding the object of the survey.

In sum, when planning the 3D survey of the monumental complex of the Holy Sepulchre, we accounted for:

- minimizing the number of range maps in order to reduce costs and times;
- trying to completely acquire the whole surface of the object in order to produce a final digital model with no unsampled areas (so-called 'holes');
- a sufficient degree of overlap between range maps owing to necessities intrinsic

- to the subsequent processing phases;
- acquiring data from as orthogonal a direction to the surface as possible, in order to guarantee maximum accuracy in the measurement process.

2.2.2.5. Scan alignment and referencing

Every range map is initially referred to the system intrinsic to the scanner. Therefore, it is necessary to subsequently define the parameters of the geometric transformations needed to place the coordinates of the various scans in a single system. The final reference system can correspond to the intrinsic system of one scan, or be defined independently from the acquisitions. In the case of the monumental complex of the Holy Sepulchre, the laser scanner survey is referenced in a pre-set topographic system.

2.2.2.5.1. Scan alignment with homologues points

A good overlap is needed between adjacent range maps, so that pairs of homologues points can be identified in the common area. Object features, such as corners or projecting parts, can be used as well as significant variations in reflectance on geometrically uniform surfaces, or targets positioned on the scene.

In the first case, the precision with which the points can be collimated obviously depends on the precision of the scanner used as well as the scan resolution. A laser scanner will practically never acquire a point in exact correspondence with a corner, and the same corner observed from two different points of view will be best represented by a pair of definitely distinct points. Therefore, we used manual recognition of corresponding natural points only to define an approximate alignment.

Almost all the scans were aligned thanks to *special targets*, automatically recog-

nized by the software. Thus, we were able to make great use of automatism, both in the signal recognition phase and in pairing the scans, therefore considerably reducing the processing times.

2.2.2.5.2. Considerations on the acquisition geometry

In the acquisition phase, it is important to ensure an overlapping area between adjacent scans that can not only provide additional documentation of the undercuts, but also geometric information useful for linking the scans themselves.

In order to manage the range maps we used Cyclone software (Leica Geosystems). With this system several types of constraint can be taken into consideration at the same time:

- points of known coordinates, consisting of high-resolution acquired targets which at the same time can be measured with topographic methods,
 - common surface between range maps.
- The first type of constraint was used both to align the scans and to place them in the topographic reference system. The second type of constraint, based on

the common surface between a pair of range maps, proved to be particularly effective in linking scans of very complex zones. Indeed, the results of the data elaboration are heavily conditioned by the morphology of the area of overlap: in the alignment process almost flat surfaces require greater overlap and to consider a large percentage of points, while a smaller common area is sufficient if the surface features more complex geometries. In this case the recording is based on the shape of the object: if it has a lot of asymmetrical irregularities, the range maps tend to ‘slot in together’ correctly; if, instead, there are few three-dimensional features, the alignment algorithm is not able to come up with a single solution. Obviously the possibility of limiting the overlap between adjacent scans clashes with the need to document the undercut areas too.

After the definition of the constraints (corresponding points, points of known coordinates, bonds between common surfaces, but also correspondence between plane or three-dimensional shapes), pair by pair of range maps, the Cyclone software makes an overall optimization of the aligned data.



FIGURES 21 AND 22 Range maps highlighting the targets used for alignment and the scan reference system.

2.2.3. Survey campaigns

The survey was performed using integrated techniques (topography, photogrammetry and laser scanners) over three data acquisition campaigns, as summed up in the table at right.

2.2.3.1. Data acquired during the survey campaigns

2.2.3.1.1. Campaign 1: 16 April - 30 April 2007

The survey campaign with Leica HDS3000 time-of-flight scanner lasted a total of 62 hours on the field. Two teams of two people each worked alternately day and

TABLE 3 SURVEY CAMPAIGNS

	1 ST CAMPAIGN	2 ND CAMPAIGN	3 RD CAMPAIGN
TIMES	April 2007	January/February 2008	November/December 2008
INSTRUMENTS	1 time-of-flight scanner 1 total station 1 semi-metric camera 1 calibrated digital camera	1 phase-shift scanner 2 total stations 1 calibrated digital camera	1 phase-shift scanner 1 total station 1 digital camera
TEAM	4 people, in 2 work teams	4 people, in 2 work teams	5 people, in 2 work teams
SCANNING DAYS	10 days	10 days	14 days
RANGE MAPS ACQUIRED	37 range maps	93 range maps	120 range maps inside the church 39 range maps on the roofs
POINTS	About 235 million	About 1 billion	About 2.5 billion
FILE SIZES (.IMP DATABASES)	5 GB	22 GB	31 GB data inside the church 21 GB data on the roofs
TOPOGRAPHIC VERTICES	6 vertices	34 vertices	40 vertices
TARGETS USED TO REFERENCE THE SCANS	83 targets	58 targets	154 targets inside the church 57 targets on the roofs



FIGURES 23 AND 24 Example of scan acquired with a $360^{\circ} \times 155^{\circ}$ field; it is visualized in a cylindrical projection; the angular reference system is the one illustrated in the figure below; the intrinsic Cartesian reference system originates in the instrument centre, vertical Z axis and random X and Y orientation, defined by the instrument position.

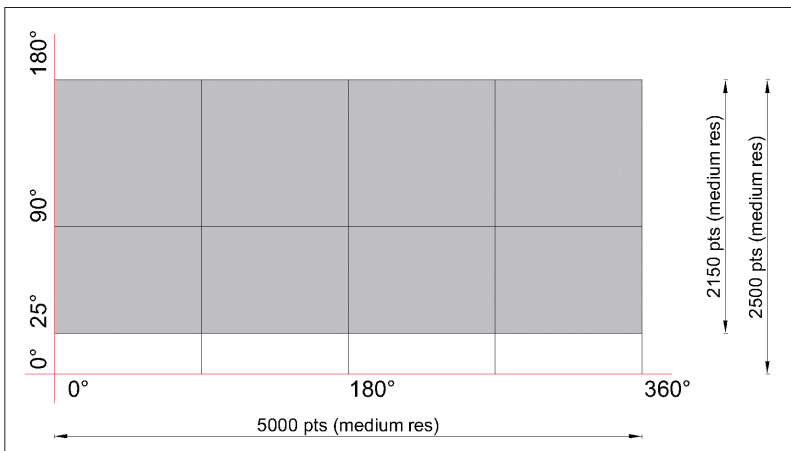

FIGURE 25 Diagram of the spherical reference system, projected onto a plane, in which the data was initially acquired, and quantification of the points survey with a medium resolution scan.

night, to maximize the productivity of the scanner, whose rate was quite slow: 3 hours for each scan, and this also made it difficult to charge the pair of available batteries alternately. The scan alignment was organized in sub-projects, containing the data relating to the *Anastasis*, the square, and the entrance area, for a total of 37 scans. The overall points model consists of around 235 million points (around 5 GB) and it was aligned in the reference system defined by a first topographic traverse measured in the same campaign.

2.2.3.1.2. Campaign 2: 24 January-8 February 2008

In the second campaign a phase-shift scanner was used (Leica HDS 6000). The higher operating speed compared to the 3D scanner used in the previous campaign meant that a much higher number of scans were made. Two teams of two operators took part in the survey, one of which allocated to making topographic measurements and the other to laser scanning. Therefore, even though the scanner work time was halved, the number of scans made was almost doubled. Again in this case, the scan alignment was organized according to sub-projects, each one containing the data relating to significant portions of the surveyed spaces: the entrance, chapels on Calvary, *Katholicon*, apse and ambulatory, the “Arches of the Virgin” area (ground and first floor), Armenian chapel on the first floor, Chapel of St. Helena and the courtyard of the Franciscan convent, for a total of 93 scans.

2.2.3.1.3. Campaign 3: 19 November-12 December 2008

In the third campaign, the same Leica HDS 6000 scanner was used. Two teams of two operators took part in the survey, one of which allocated to acquisition with the laser scanner and the other to pre-processing the acquired data. The great increase in the number of scans was also due to the availability of the control network

measured in the previous campaign, the greater accessibility to the roof level and to the fact that the internal areas surveyed were not accessible to the pilgrims. The scan alignment was organized according to sub-projects, each one containing the data relating to the different surveyed areas. With regard to the internal spaces: Armenian sacristy, Chapel of the Apparition, Chapel of the Crusaders, part of the Copt convent, Chapel of the Franks, part of the Greek convent, remains of the quarry near to St. Helena and Chapel of St. Vartan, the Christian Road, the Ethiopian chapels, Joseph of Arimethea’s burial place, rooms formed in the *Anastasis* ambulatory, exterior of the *Rotunda*, Franciscan sacristy and Greek sacristy, for a total of 120 scans. A further 39 scans were made on all the roof structures.

2.2.3.1.4. Quantifying the acquired data

The scans were made according to a field of view of 360° horizontally and 155° vertically (therefore only excluding the cone-shaped shadow cast by the tripod). In order to acquire the internal spaces, we generally operated at distances of 10-25 m from the surfaces in question; as a result, we set a ‘medium’ resolution, corresponding to points acquired at angular intervals of 1.26 mrad – that is, 1 point/12 mm at a distance of 10 m and 1 point/3 cm at a distance of 25 m.

By way of example, below is a consideration of the technical characteristics of the HDS6000 laser scanner used in the last two measurement campaigns.

As highlighted in the previous outline, a ‘medium’ resolution corresponds to an acquisition consisting of 5,000 x 2,150 points, namely 10.75 million points. The indoor scans from the last mission, almost always made with a medium resolution, make up an overall database of over 1 billion points, and the external scans of over 1.5 billion points.

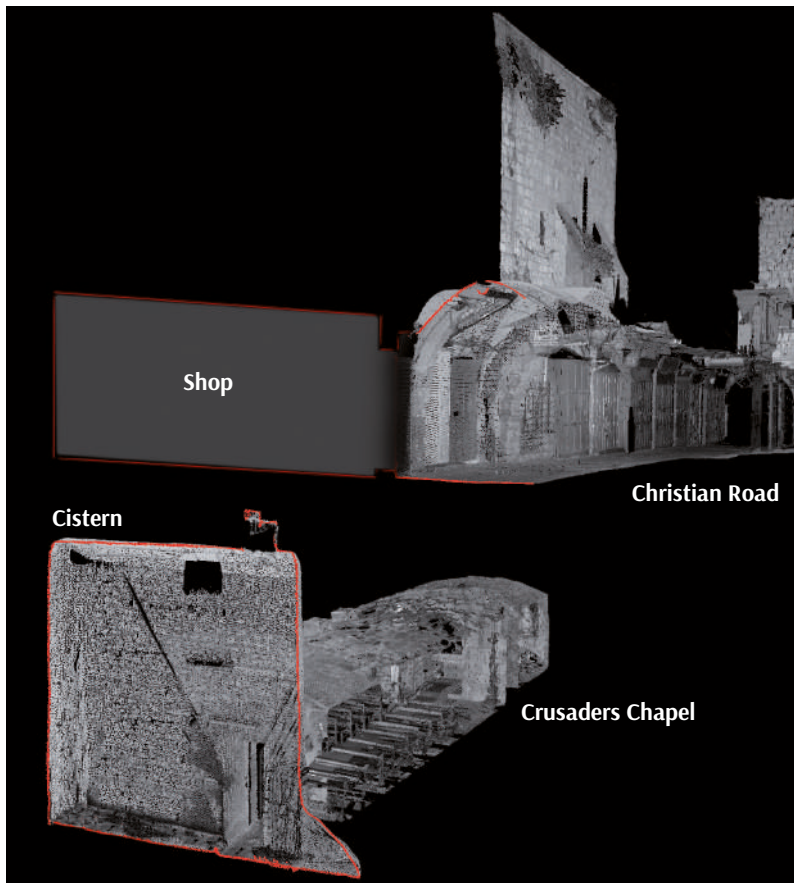

2.2.3.2. Topographic control network and reference system

The aim of the topographic control network is to materialize and define, through a limited series of evenly distributed points, the three-dimensional reference system to which the subsequent survey operations will be referred.

During the first survey phase, the reference system was defined by measuring a control network extended over the whole architectural complex, materialized in a stable manner. The reference system has a false origin corresponding to the V30 vertex (1000m, 1000m, 500m) and north-directed Y-axis.

As a result, it was possible to gather all the data collected (indoor and outdoor, even in not directly connected areas) within a single model and to make metrically correct evaluation of the spatial relationships. Consider, for example, the difference in height between the Christian

Road, which traces the western boundary of the structure, and the cistern close to the Crusaders Chapel.

The coordinates of the control network vertices were calculated and adjusted using least squares method.

2.2.3.3. Topographic traverses

In order to extend the reference system to all the areas to be surveyed, the main control network was integrated by linked traverses; station markers were fixed securely and station witness diagrams were sketched in order to record survey's metadata, to simplify the retrieval process and to enable the data to be updated subsequently.

A link traverse, bound to the vertices of the main network, was measured on the roof of St. Helena, along the adjacent road and inside the Copt convent.

Another one crossed the chapels of the

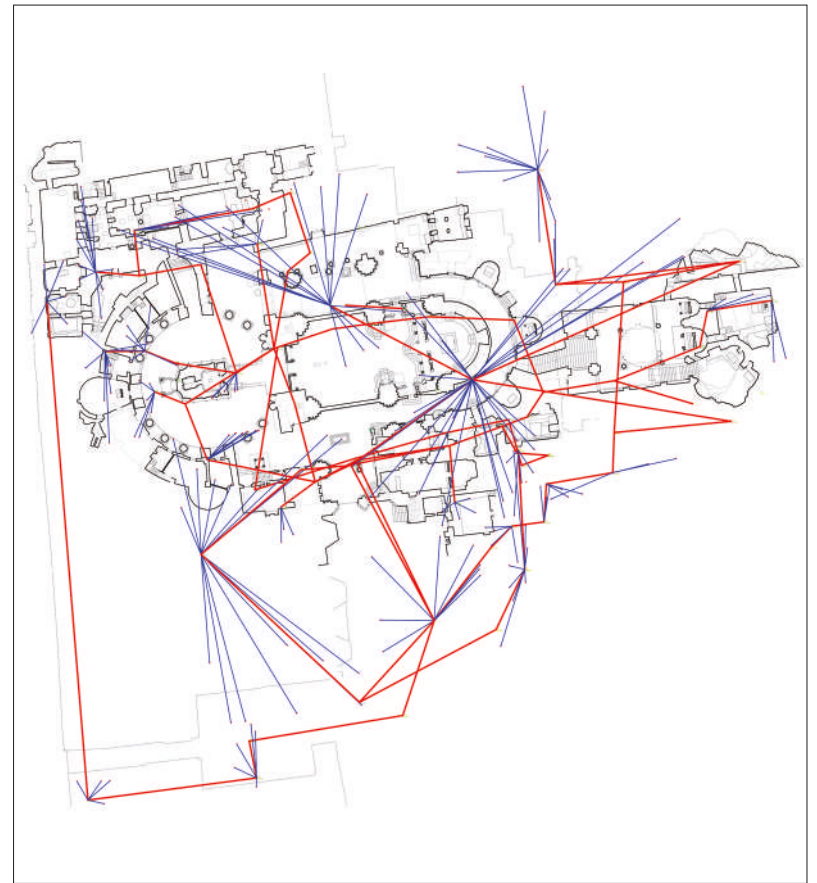

Ethiopian Copts, connecting at one end to the station markers present in the square and at the other end to those on the roof of St. Helena's.

Inside the monumental complex, a traverse was set between the known vertices on the lower level in the corridor in front of the rock of Golgotha, and on the higher level in the Greek chapel; the new vertices were fixed along the staircase and in the rooms immediately behind Golgotha.

In the lower floor of the Franciscan convent a link traverse was measured between the fixed vertices on the lower level of the *Rotunda*; the new vertices were fixed in the Franciscan sacristy, along the corridor of the convent and in the courtyard.

In order to reach all the spaces surveyed by laser scanner and thus to measure the targets for scan data alignment, it was necessary to plan also some open traverses; in order to limit the errors, spurs

FIGURE 26 Graphical elaboration showing some not directly understandable spatial relationship between not directly connected spaces, as the cistern close to the Crusaders Chapel (down) and Christian Road (up).

FIGURE 27 Topographic control network diagram (in red) and target (in blue).

2.2.4.1. Data storage and digital preservation

During the acquisition phase, the instrument settings (scan resolution, acquisition area, file names, etc.) were controlled by a PC through a web browser. The data was recorded in the internal hard disk of the scanner, from which it was downloaded and imported into the data management software (Cyclone, Leica Geosystems).

Memorizing and filing the data acquired through scanning is part of the wider issue of the preservation and accessibility of digitalized information.

The “*Charter on the Preservation of the Digital Heritage*” (text adopted by the UNESCO General Conference in 2003) specifies that «Continuity of the digital heritage is fundamental. To preserve digital heritage, measures will need to be taken throughout the digital information life cycle, from creation to access. Long-term preservation of digital heritage begins with the design of reliable systems and procedures which will produce authentic and stable digital objects» [UNESCO, 2003].

The specific problems with the data from the scans result from its immense amount: for example, if we are to exclusively consider geometric information, the last two campaigns acquired around 20 GB – January/February 2008 campaign – and around 50 GB – November/December 2008 campaign (since an instrument with different characteristics was used during the first campaign, significant comparisons cannot be made).

With regard to filing the data, we chose to make a controlled copy of the information on hard disks.

In order to guarantee the possibility to access the data independently from the currently available software, it was

exported in PTS format, an ASCII format which, after a heading containing the number of lines (points) in the file, memorizes a list of coordinates and the corresponding intensity value.

Lately, a new open standard (.E57) has been proposed for storing data produced by tridimensional imaging systems, such as laser scanners. Improving our surveys archive to guarantee interoperability and the possibility to reuse the data collected in past projects, is a current challenge for our laboratory and a cutting edge topic for researchers who are working with this kind of data.

2.2.4.2. Data management

The great quantity of data acquired over the three campaigns (in all over 3 billion points) means that it was not possible to visualize and above all to manage the whole model at the same time, even working with the best PC available at that time. Therefore, it was necessary to structure the database according to smaller subprojects. This division, already set during the acquisition phase, was made considering the spatial layout of the surveyed structures in order to make it easier for subsequent analyses on architecturally coherent portions.

The common reference system used by the different subprojects first enabled their partial reassembly into four macro projects and then the joint visualization of all the data acquired inside and outside the monumental complex.

Just few years later, with updated hardware, we are today able to visualize in real time all the data acquired.

The tables in the following pages show the position and extension of the various subprojects.

List of the subprojects

1. ROTUNDA
2. SQUARE AND FACADE
3. APSE
4. CHAPEL OF ST. HELENA
5. ENTRANCE AND GOLGOTHA
6. ARMENIAN CHAPEL
7. CATHOLICON
8. ARCHES OF THE VIRGIN
9. ARCHES OF THE VIRGIN – 1ST FLOOR
10. FRANCISCANS' COURTYARD
11. ARMENIAN SACRISTY
12. CHAPEL OF THE APPEARANCE
13. CHAPEL OF THE CRUSADERS
14. “CHURCH” UNDER THE COPTIC PATRIARCHATE
15. CHAPEL OF THE FRANKS
16. GREEK CONVENT
17. CHRISTIAN ROAD
18. ST. HELENA'S QUARRY
19. ETHIOPIAN CHURCH INTERIORS
20. JOSEPH OF ARIMATHEA
21. GOLGOTHA BACKSIDE
22. ROTUNDA EXTERIOR
23. ROTUNDA ROOMS
24. FRANCISCAN SACRISTY
25. GREEK SACRISTY
26. EGYPTIAN ROOFS
27. ETHIOPIAN ROOFS
28. FRANCISCAN ROOFS
29. GREEK ROOFS LOWER LEVEL
30. GREEK ROOFS UPPER LEVEL / 1
31. GREEK ROOFS UPPER LEVEL / 2

1

Subproject: ROTUNDA

N. scans: 34

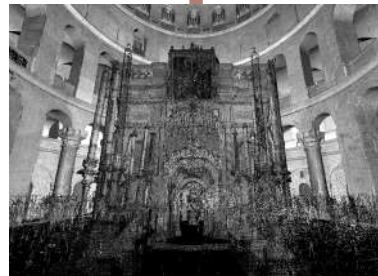
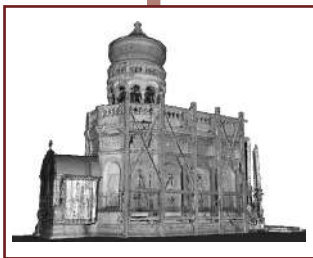
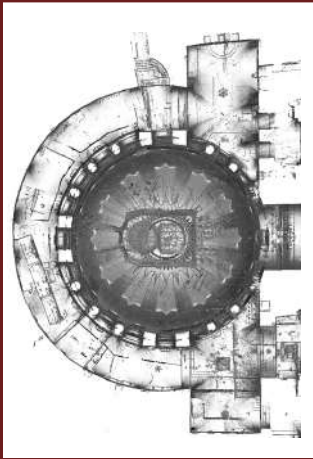

2

Subproject: SQUARE AND FACADE

N. scans: 3

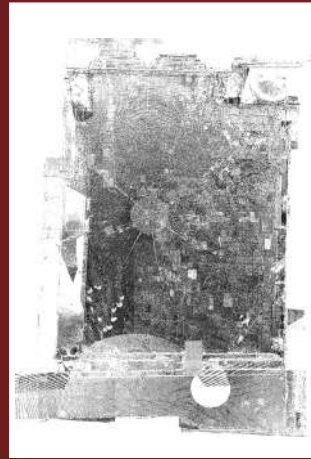
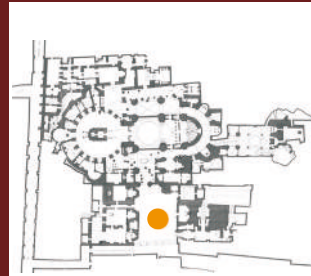

3

Subproject:
APSE

N. scans: 10

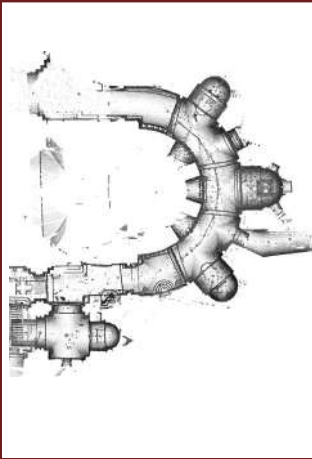

4

Subproject:
CHAPEL OF ST. HELENA

N. scans: 21

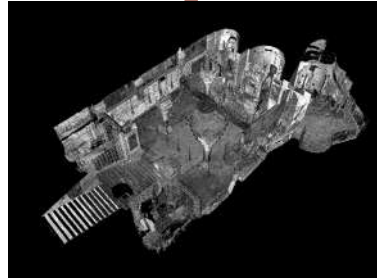
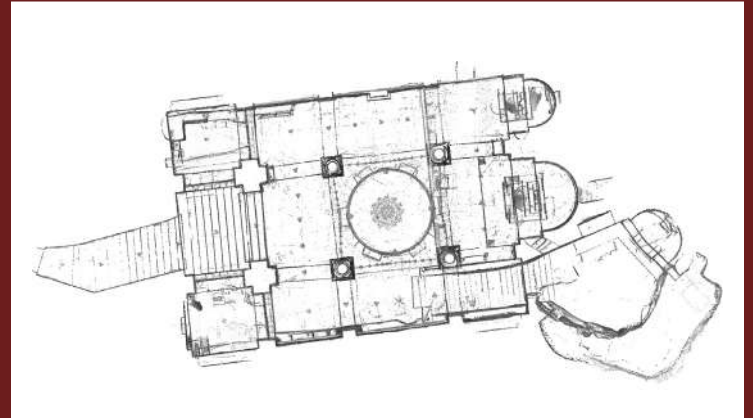
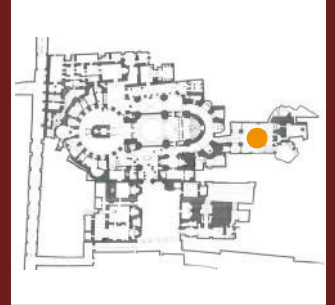

5

Subproject: ENTRANCE AND GOLGOTHA

N. scans: 10+5

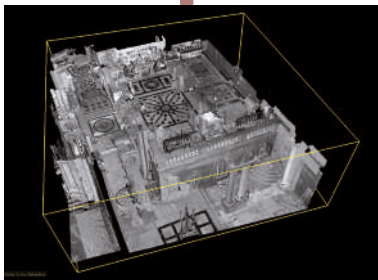
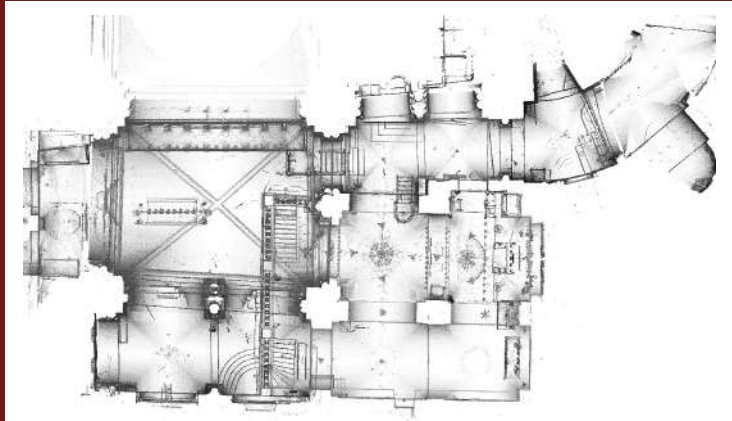

6

Subproject: ARMENIAN CHAPEL

N. scans: 8

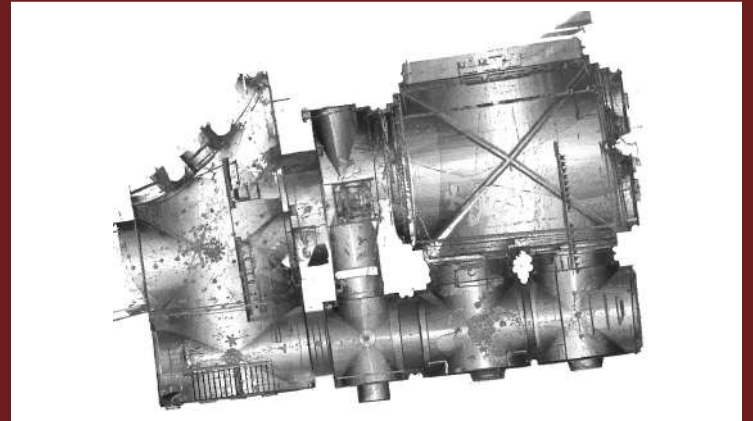
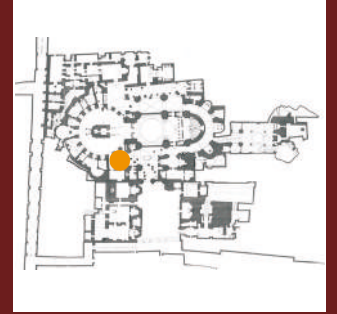

7

Subproject:
CATHOLICON

N. scans: 15

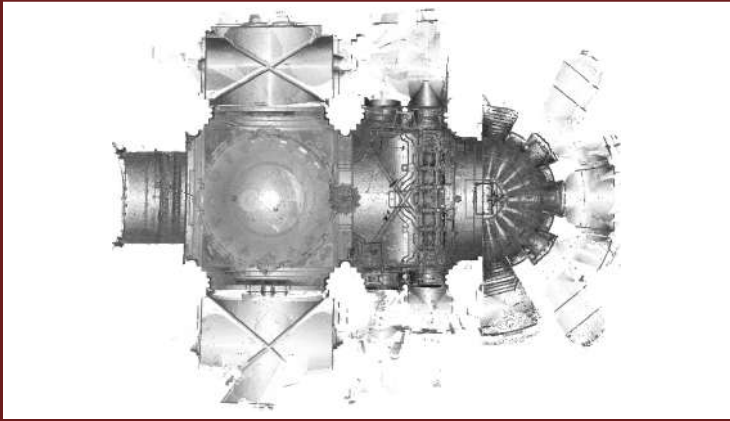

8

Subproject:
ARCHES OF THE VIRGIN

N. scans: 9

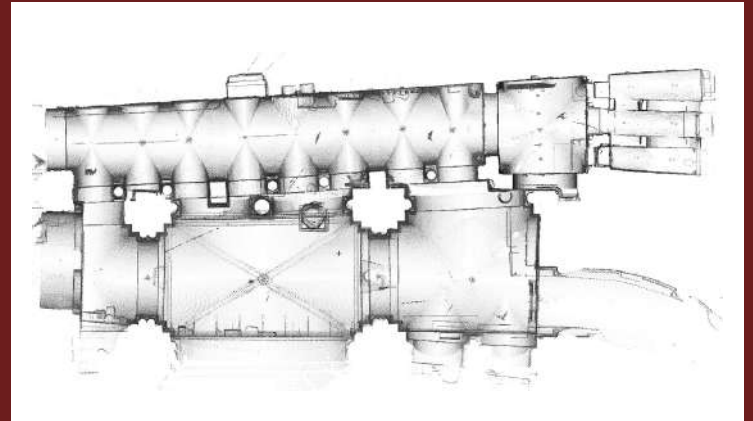
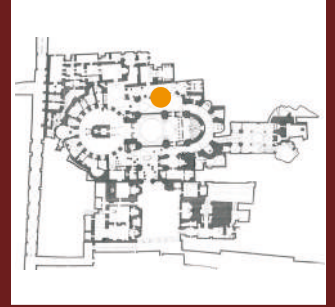

9

Subproject:
**ARCHES OF THE VIRGIN –
1ST FLOOR**

N. scans: 8

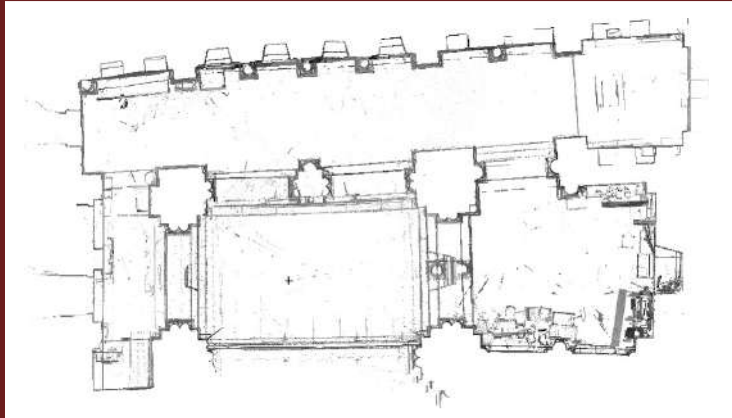

10

Subproject:
FRANCISCANS' COURTYARD

N. scans: 8

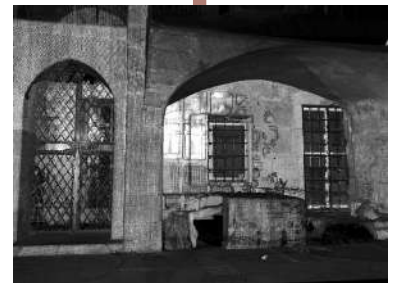
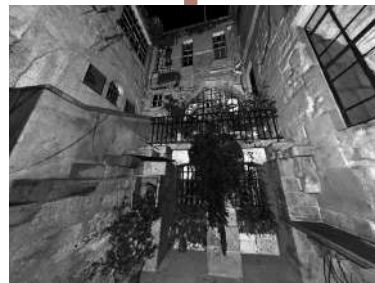
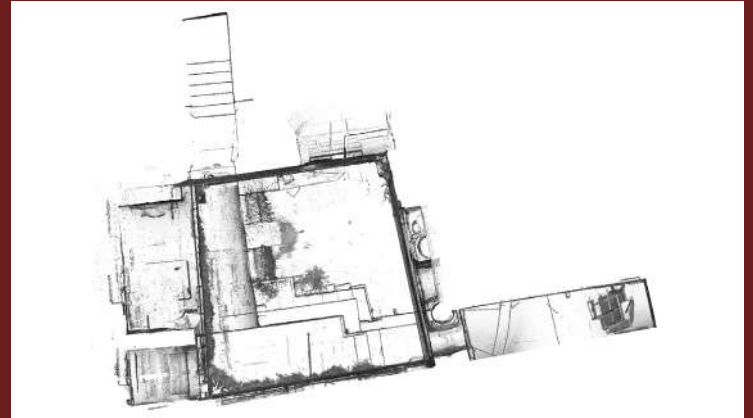
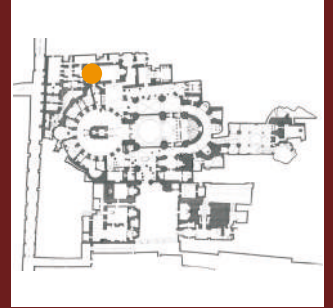

11

Subproject:
ARMENIAN SACRISTY

N. scans: 2

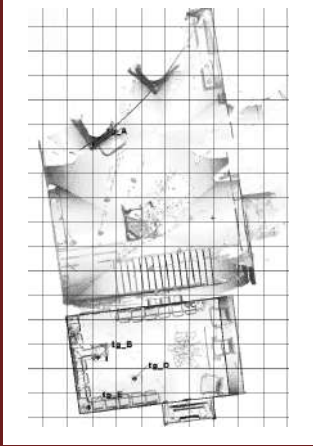
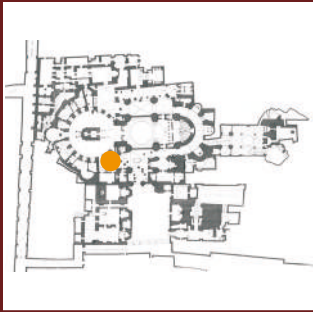

12

Subproject:
CHAPEL OF THE APPEARANCE

N. scans: 3

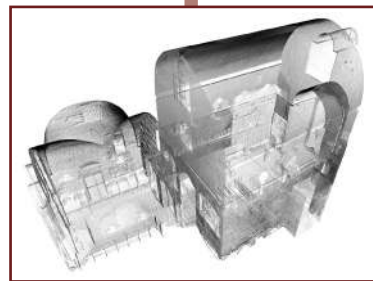
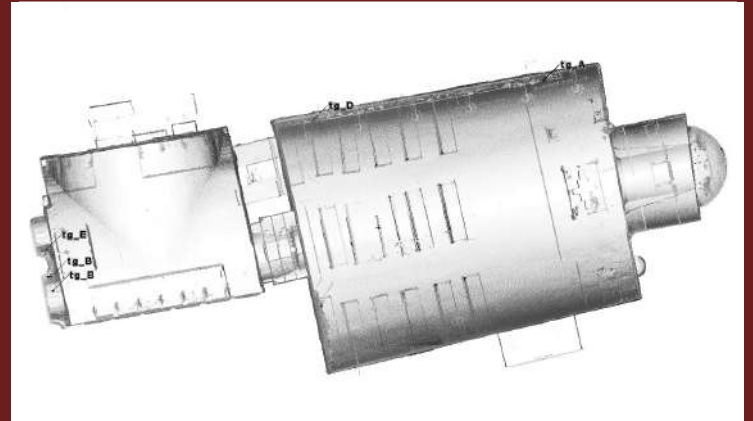
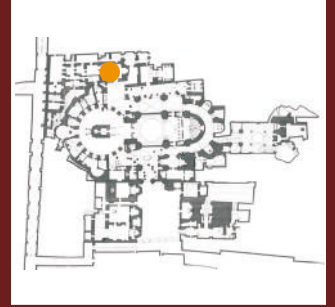

13

Subproject: CHAPEL OF THE CRUSADERS

N. scans: 9

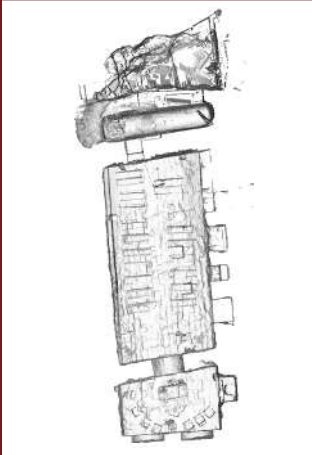

14

Subproject: "CHURCH" UNDER THE COPTIC PATRIARCHATE

N. scans: 12

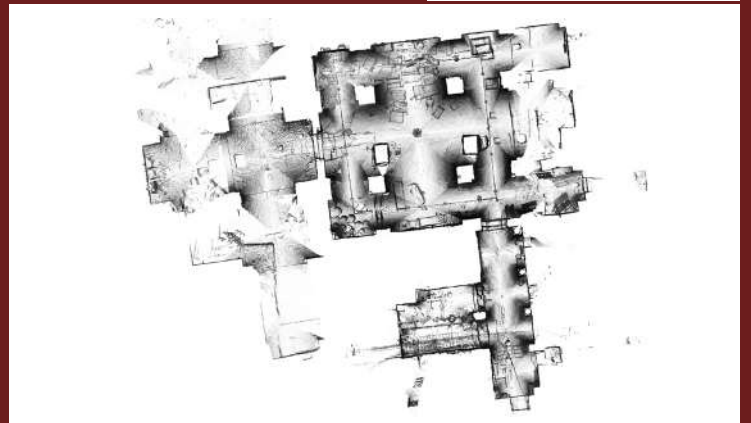
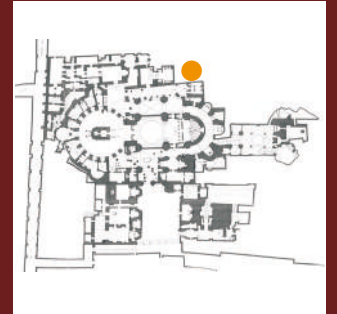

15

Subproject:
CHAPEL OF THE FRANKS

N. scans: 3

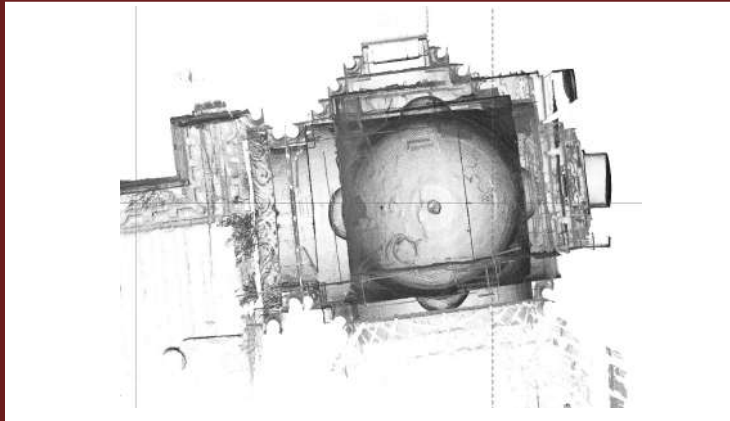

16

Subproject:
GREEK CONVENT

N. scans: 10

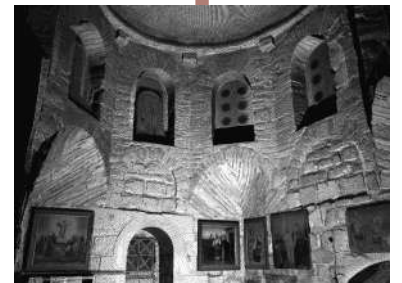
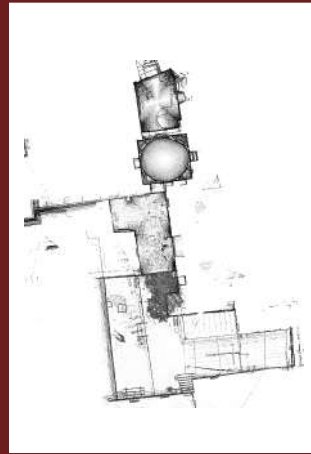
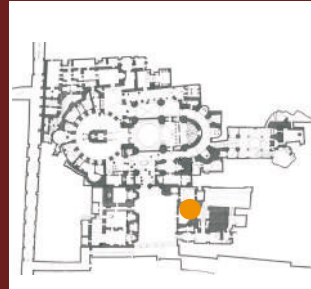

17

Subproject: CHRISTIAN ROAD

N. scans: 9

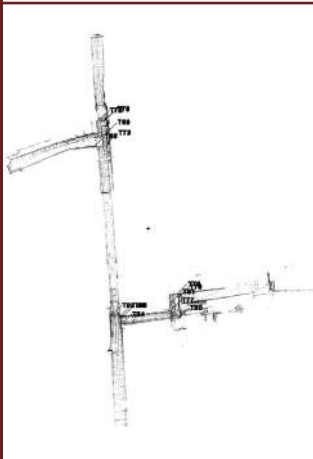
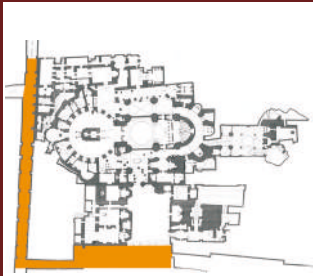

18

Subproject: ST. HELENA'S QUARRY

N. scans: 12

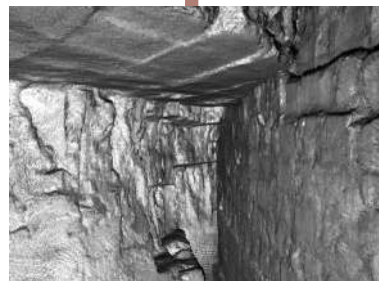
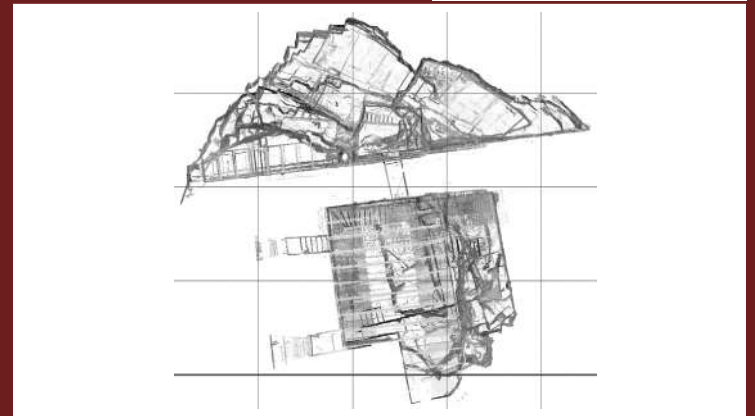
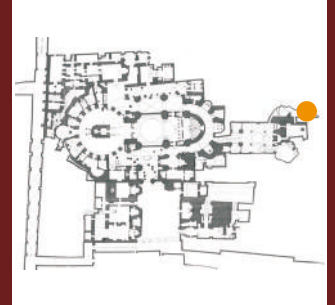

19

Subproject:
**ETHIOPIAN CHURCH
INTERIORS**

N. scans: 12

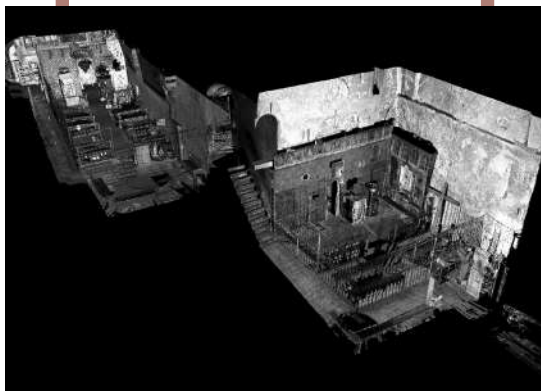
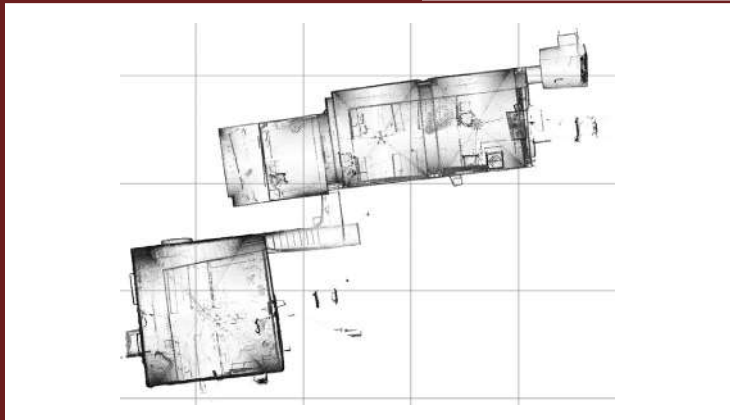

20

Subproject:
JOSEPH OF ARIMATHEA

N. scans: 7

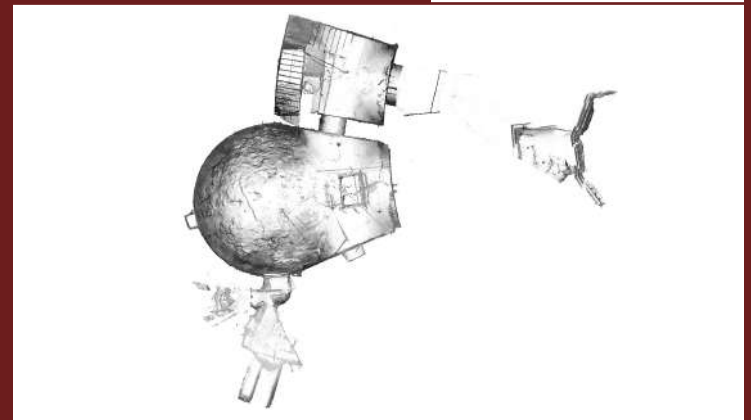
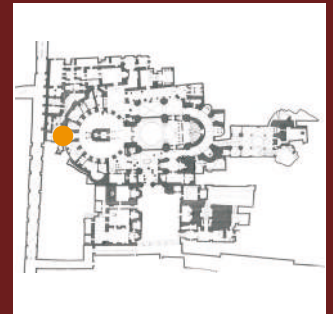

21

Subproject:
GOLGOTHA BACKSIDE

N. scans: 9

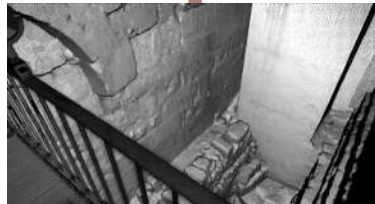
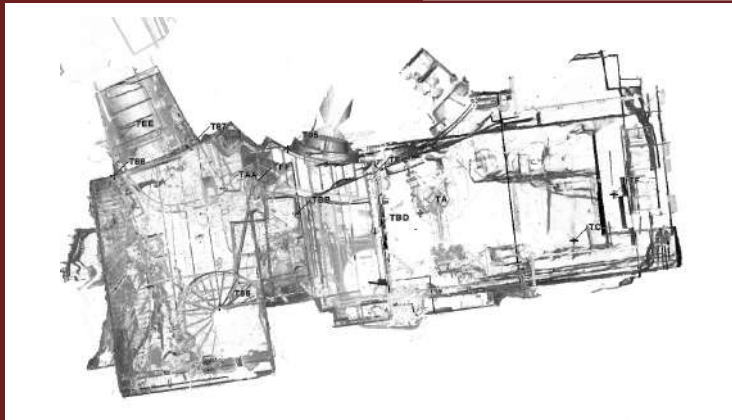
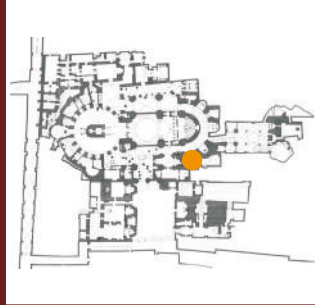

22

Subproject:
ROTUNDA EXTERIOR

N. scans: 12

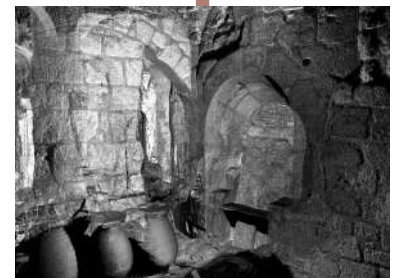
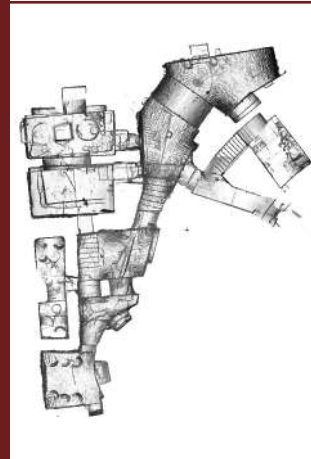

23

Subproject:
ROTUNDA ROOMS

N. scans: 8

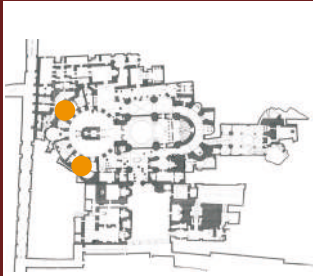

24

Subproject:
FRANCISCAN SACRISTY

N. scans: 12

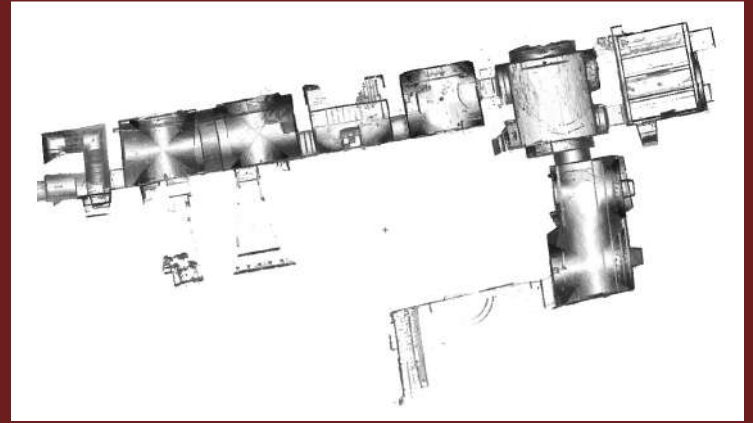
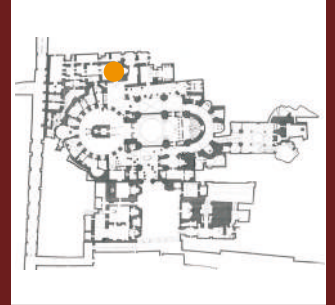

25

Subproject:
GREEK SACRISTY

N. scans: 9

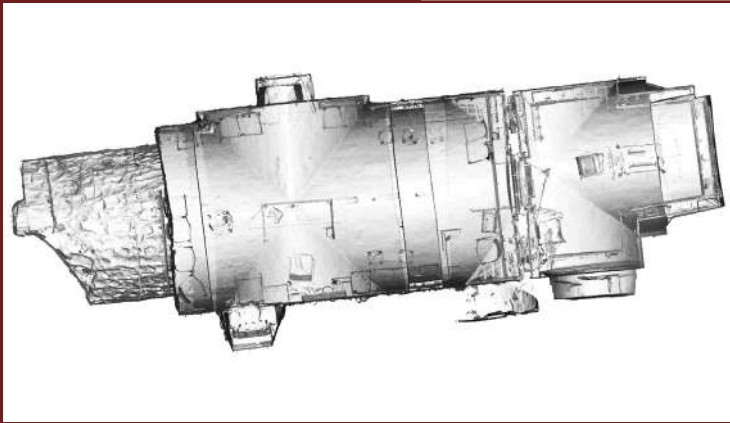
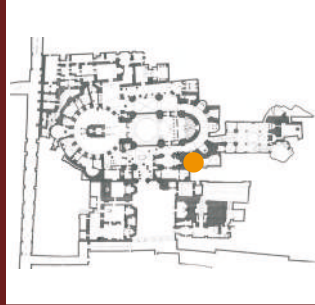

26

Subproject:
EGYPTIAN ROOFS

N. scans: 9

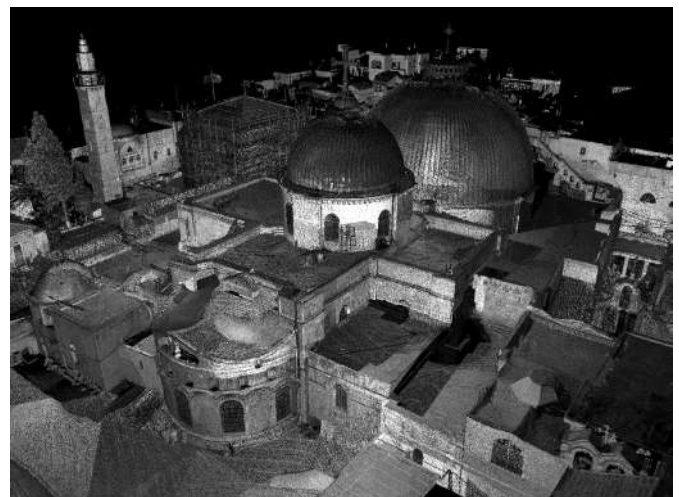

27

Subproject:
ETHIOPIAN ROOFS

N. scans: 7

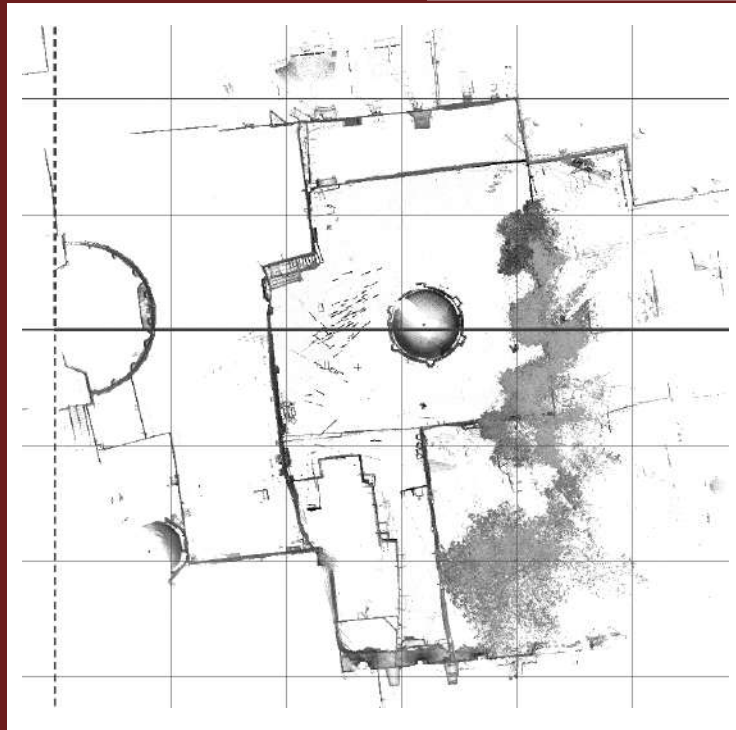

28

Subproject:
FRANCISCAN ROOFS

N. scans: 6

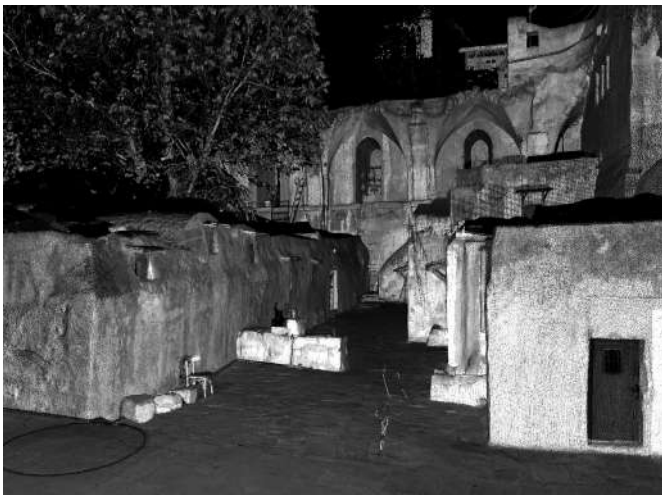
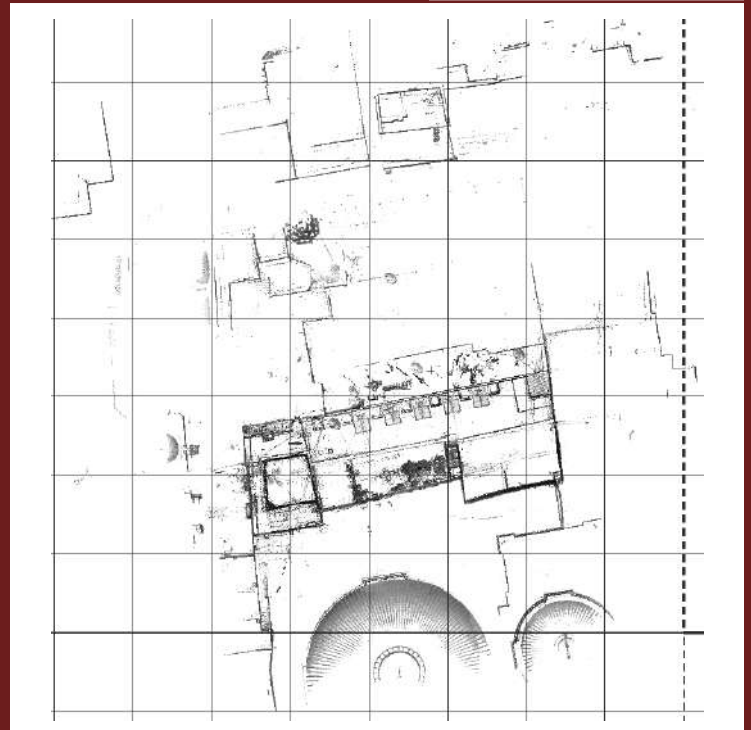

29

Subproject:
GREEK ROOFS LOWER LEVEL

N. scans: 3

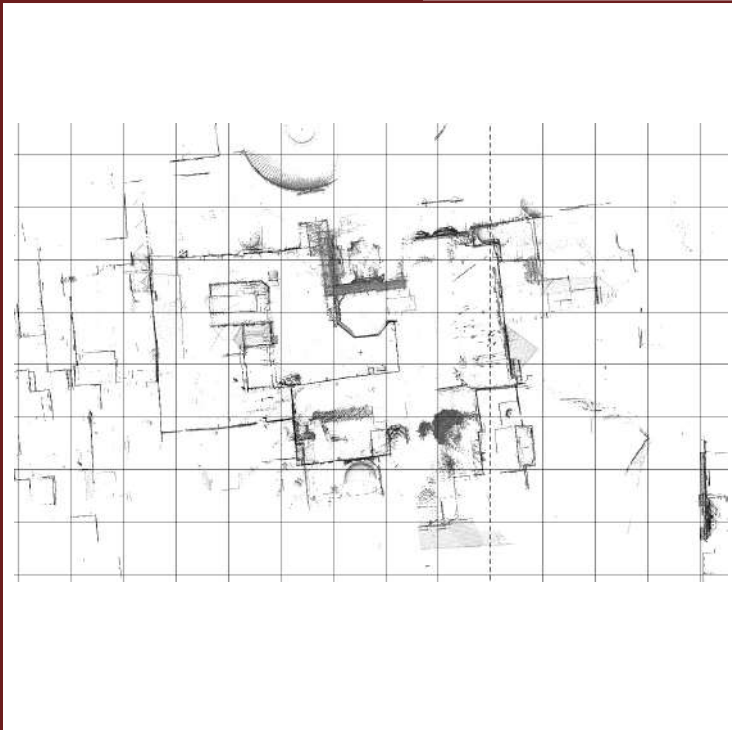

30

Subproject:
GREEK ROOFS UPPER LEVEL / 1

N. scans: 10

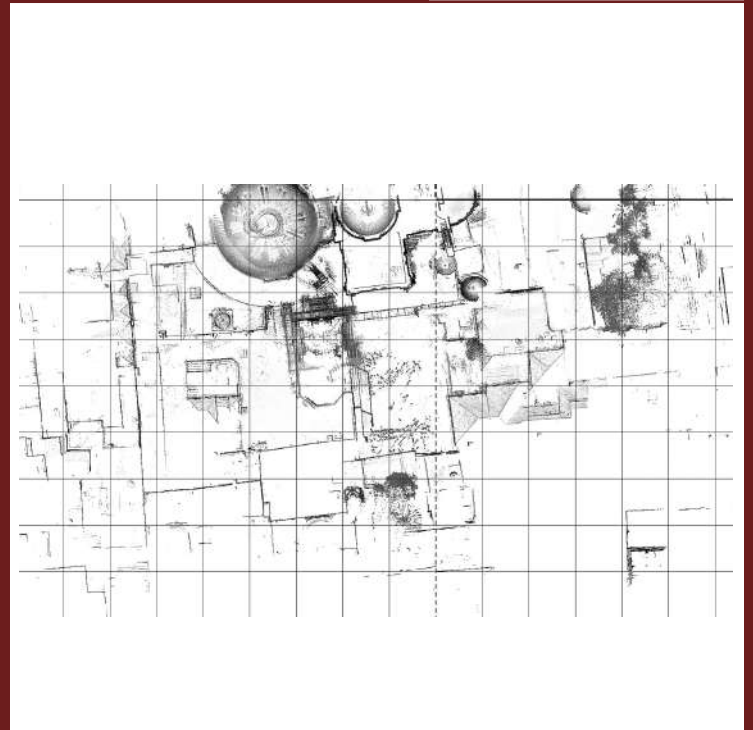
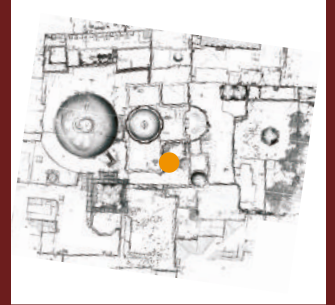

31

Subproject:
GREEK ROOFS UPPER LEVEL / 2

N. scans: 8

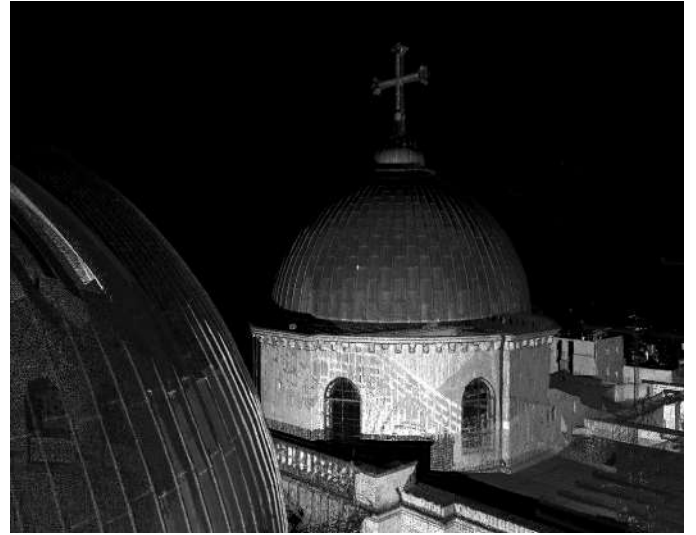
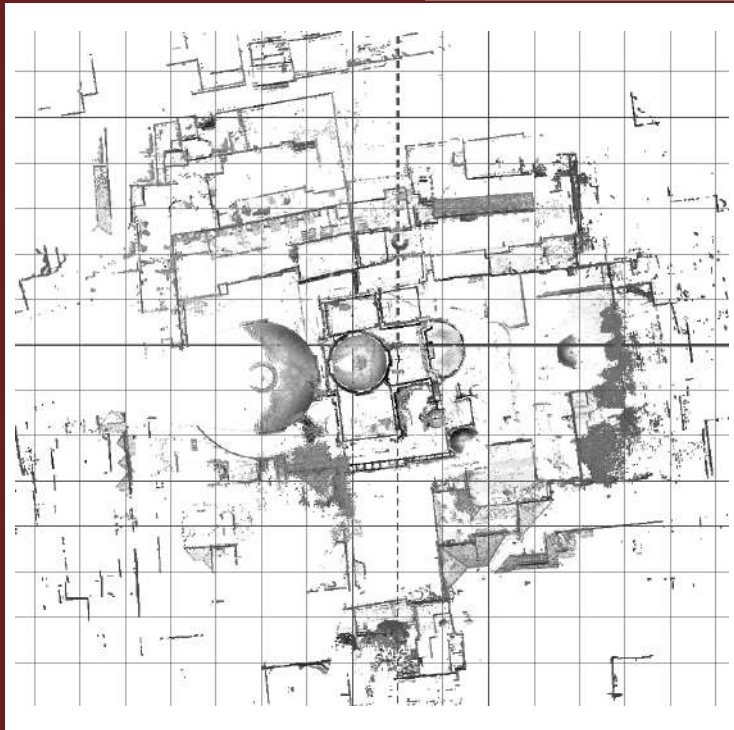



FIGURES 31 AND 32 Golgotha. On the 'point cloud' it is possible to observe the different masonry textures and therefore also distinguish the various construction phases of the building, starting from the bed rock up to the most recent works.

FIGURE 33 South Transept. On the 'point cloud' it is possible to read the typical masonry texture that characterizes the works of Constantine Monomachos.



2.2.5. Graphical outputs of the 3D survey

2.2.5.1. Preparation of the graphical output

Different graphical output can be obtained from a point cloud model.

The surfaces recorded by the three-dimensional scans can describe (depending on the acquisition resolution) not just the size and lie of the architectural elements, but also their material consistency, making masonry bond legible as well as material decay and damage. In addition, they meet the need to produce a model able to highlight particular themes.

The accumulation of great quantities of data first of all brings about problems linked to filing, cataloguing and in some cases sharing it. Issues that moreover appear with very different characteristics if we consider the raw data (this expression could be taken to mean the result of the scan recordings acquired during a measurement campaign) rather than the numerous types of graphical output that can be obtained from it.

Once all the scans have been aligned with each other and the overall point cloud put into a single reference system, it is possible to transpose the architectural survey operations from the object itself to its model. The advantages are evident and mainly linked to the convenience and flexibility created by 'virtualizing' the analyses, which is done in front of a computer rather than on site. However, the limitations are equally as important. First of all, the measurements made by the scan systems, however dense they may be, maintain their discrete nature: the point cloud is a convincing visualization and an extremely rich database of measurements, but in any case it remains a discretized representation of the object and not a complete and virtual reproduction of it. The density of the data acquired with the

scans definitely enables more accuracy and flexibility than that of a handmade or a topographic survey in which plans and sections, represented by vectorial drawings, must be defined prior to collect on-site measurements. As a result, starting from a single geometric database it is generally possible to obtain different forms of representation.

Another interesting consequence of the flexibility characterizing the data from scans consists of the potential application of the data in projects with prevalently communicative ends: the possibility of interactive exploration, associated with software tools that make the files 'lighter', making it possible to visualize them in real time, also by Internet, are aspects that are increasingly requested these days.

The following paragraphs illustrate the various two- and three-dimensional drawings obtained from the data acquired through scanning (integrated with topographic and/or photogrammetric surveys) of the monumental complex of the Holy Sepulchre.

2.2.5.2. Section profile vectorization

This type of representation always refers to 'section plane' and 'orthogonal view' concepts: plans, perspectives and section profiles can be represented by vectorializing thin portions of the point cloud, identified by horizontal and vertical section planes.

The two-dimensional nature of the orthoimages produced in the way described must not let us forget that they use the same reference system, which is nevertheless always three-dimensional: every section profile, that is, belongs to a plane, of which however the position

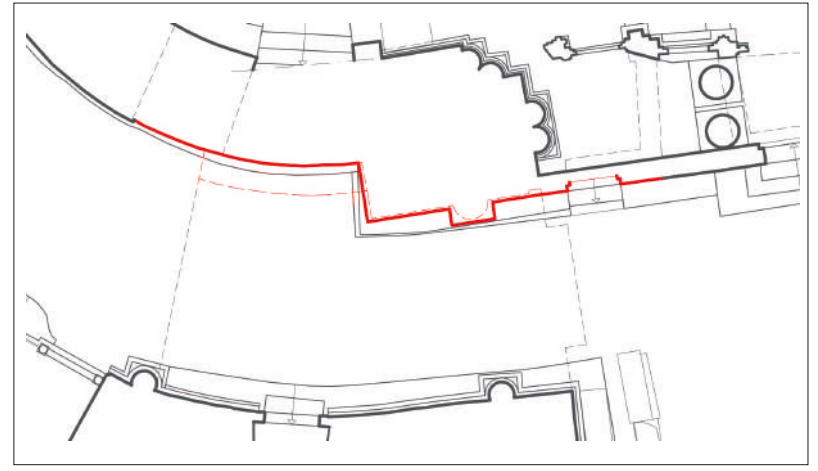
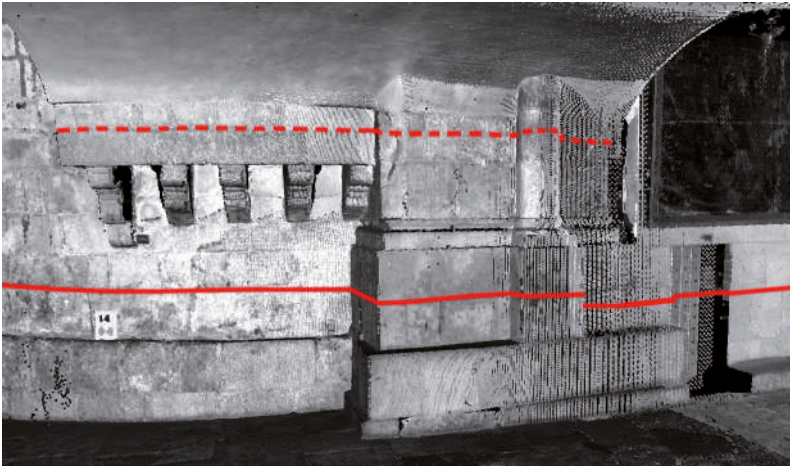

FIGURE 34 (left) Apse. Showing the different section planes used to give a full description of the architectural elements.

FIGURE 35 (right) Plan corresponding to the horizontal section planes indicated above: the reference section plane is drawn in continuous line, the immediately upper level is in dashed one.

and lie is known in the three-dimensional space defined by the adopted Cartesian reference system. Precisely with regard to this latter aspect, it is interesting to highlight analogies and differences with respect to the traditional direct survey techniques. Indeed, with direct surveys too, the reference planes need to be defined first, with the horizontal lie for the planes and the vertical lie for the elevations, in correspondence to which all the measurements must be acquired. The indispensable plotting and ongoing verification operations (in particular when the investigated spaces are complex) must however obviously be made on the real object rather than on its digital reference.

The selection and exportation of 'slices' of points was done directly with the software used to manage the scanner during the acquisition and range map recording phase. With this procedure, the profiles

needed for the modelling were extracted in accordance with the group dealing with the structural analysis.

Thanks to the orthoimages taken from the survey output it was possible to give a rapid and flexible response to the needs of the structural study which has to have three-dimensional models that are simplified from the geometrical point of view but dimensionally correct.

2.2.5.3. Vectorization of orthogonal views of the point cloud

In order for observation and exploration of the cloud to evoke the represented space, the acquired points (which from a geometrical point of view are obviously adimensional) are rendered on the screen with a finite dimension. The possibility to regulate this parameter enables optimal

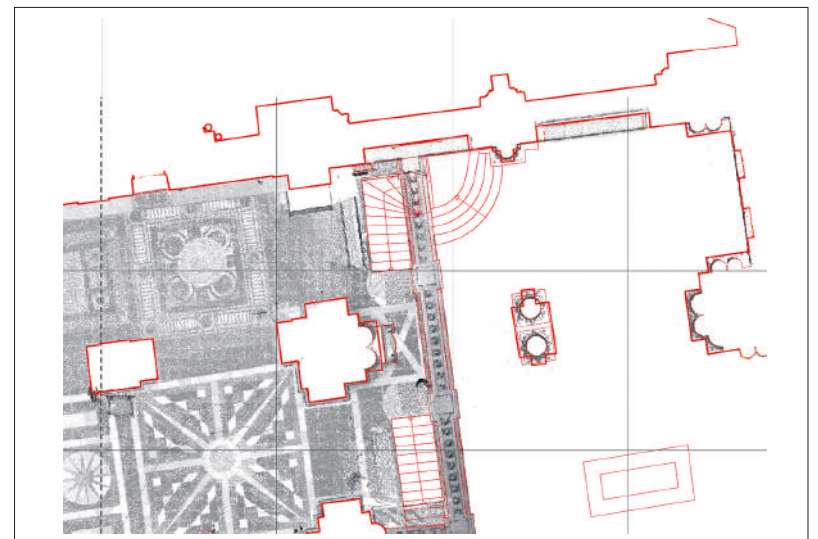
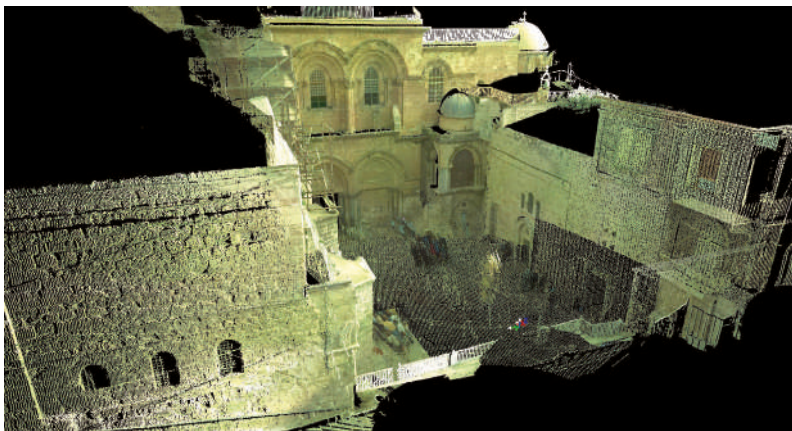
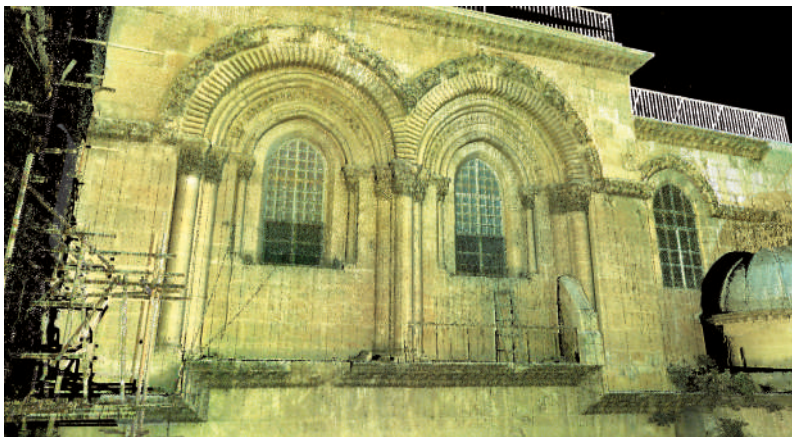

FIGURE 36 (left) Entrance. Showing the different section planes used to give a full description of the architectural elements.

FIGURE 37 (right) Plan corresponding to the indicated horizontal section planes.

FIGURE 38 It is possible to observe the light signal given off by the scanner to make a 3D measurement of the space.



FIGURES 39-40 3D texturized point cloud orthophotos of the facade and the adjacent square.

visualization of the point cloud by hiding the elements in the background. Furthermore, the false colours always associated with the points (correlated with the intensity of the reflected signal) express different characteristics of the analysed surfaces. Therefore, it is possible to establish not just a geometrical but also chromatic correspondence between object and model and capture views of the cloud corresponding to the photographic images. The vectorization of plans and elevations was carried out by setting an orthographic view of a suitable plane, defined in a similar way to that described above. The visualization obtained, which may be exported as a raster image, gave a valid metric reference in order to plot the elements in view.

2.25.4. Digital orthophotos

In order to produce orthophotos, we need to have a suitable number of control points, measured topographically and expressed in the same reference system as the model. Therefore, the orientation of the photograms is calculated, through photogrammetric technique, Nowadays some laser scanners also enable digital images to be acquired from

a camera rigidly connected to the scan head: in this case with respect to the range maps the orientation of the photograms is constant and defined by calibrating the scanner-camera set. It is nevertheless opportune to remember that distance scanning tools allow for work flexibility with regard to the environmental lighting conditions; on the other hand, the images that need to be used to make orthophotos have to have a good photographic quality. The extension framed by the scanner is also generally greater than that of a camera, therefore several photographs must be taken for every range map; however, the camera settings, the exposure in particular, are regulated once only, upon the first shot, at times to the detriment of the uniformity of the subsequent images. In many cases, these instruments can therefore provide a rapid and exhaustive documentation of the object but, when better and more uniform photographic quality is required, the best operating manner is the indirect orientation of photograms taken independently from the scans. The 3D scanner used during the first survey campaign also enables the acquisition of colour information (RGB values associated with every measured point). The difficult lighting conditions of the spaces did not enable use of this function inside the

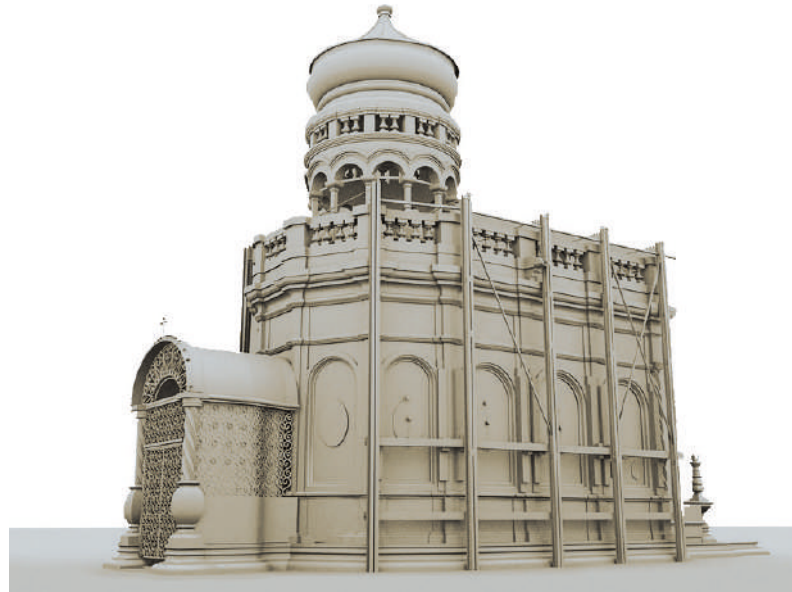

FIGURE 41 3D model of the *Aedicula* of the Holy Sepulchre.

monumental complex, but it was used in the square in front of the entrance.

The wealth of data contained in the photographs can only be transformed into information that is useful for subsequent studies through the critical interpretation of specialists. In some cases, it may be the case to obtain a complete, albeit less precise, photographic representation of a rigorous scale model. To this end the digital photographic documentation, also acquired rapidly, can be retrieved with simplified calibration procedures; it is obviously fundamental to highlight that the metric validity of the drawings produced is definitely inferior to that requested for traditional representations at an equivalent scale.

During the survey campaigns, complete photographic documentation was acquired, which to date has not been processed since this is not necessary for the purpose of the project. However, this could enable the previously described graphical output to be created.

2.2.5.5. Videos

Understanding complex spaces represented by a points model is made particularly difficult by the inevitable transparencies generated by the discontinuity of the

data. Unlike surface models, point clouds appear continuous if observed from a sufficiently distant viewpoint, but they become discontinuous as the observer gets closer. The software's visualization tools and the possibility to explore the model in a dynamic manner partially make up for the difficulty in interpreting this type of three-dimensional data. Transposition into a two-dimensional space and in particular printing on paper further penalize its communicative potential.

Optimal visualization of the points model is possible in special software environments where the user can explore it interactively; in this case, however, PCs with superior characteristics and specific features are needed.

By making films that follow set routes, it is possible to explore the model and enhance the three-dimensional characteristics, at the same time enabling circulation amongst a wider set of users.

2.2.5.6. Surface models

Representing the subject of the survey using surface models leads to interesting results: indeed, if the acquisition resolution and geometry of the recordings is suitably planned, the accuracy of measurement that can be achieved

with distance scanners enables not just the overall geometric consistency of the building to be documented, but also to distinguish the materials making it up and in some cases their state of preservation. Whether it is a good idea to make models with this level of definition must be given careful assessment, since they can be particularly costly considering the quantity of data that needs not only to be acquired, but also processed and filed.

In addition to the graphic renderings analysed thus far, whose main objective is to make the metric contents of the information immediately interpretable, also on a paper medium, there are others which more evidently maintain the three dimensions of the original data, such as triangular mesh-based or shaded surface models, or those associated with the projection of 3D orthophotos.

To make the 3D model of the current conditions of the monumental complex, we decided to start working on the most important symbolic element (the *Aedicula* of the Holy Sepulchre, as depicted in Fig. 41), to then extend the study to the *Anastasis* and finally to the rest of the building.

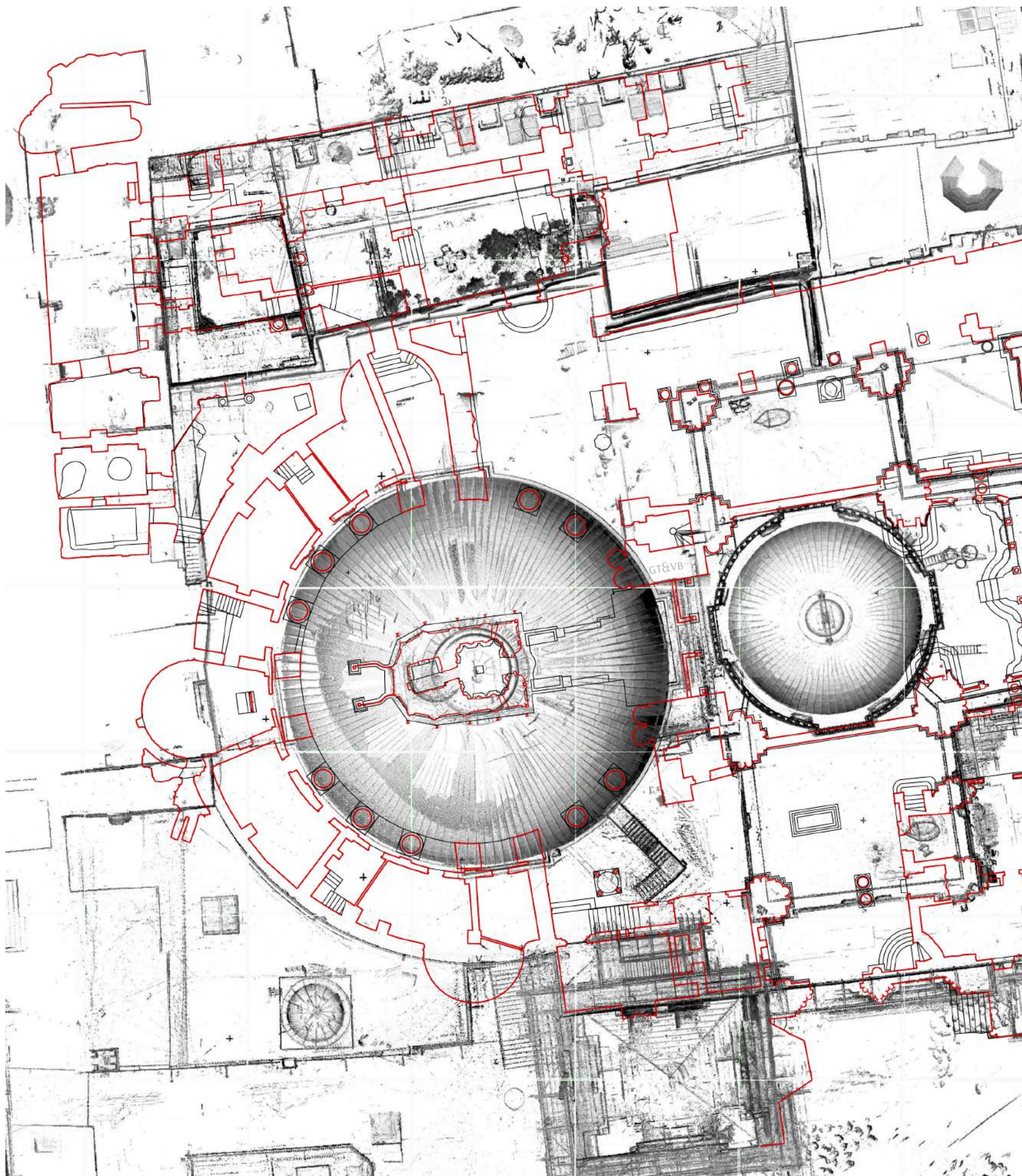



FIGURE 43 Superimposition of the 3D point cloud of the roof of the Complex of the Holy Sepulchre with the plan of the ground floor (Tucci-Bonora surveys 2007-2009).



2007-2010 Grazia Tucci and Valentina Bonora

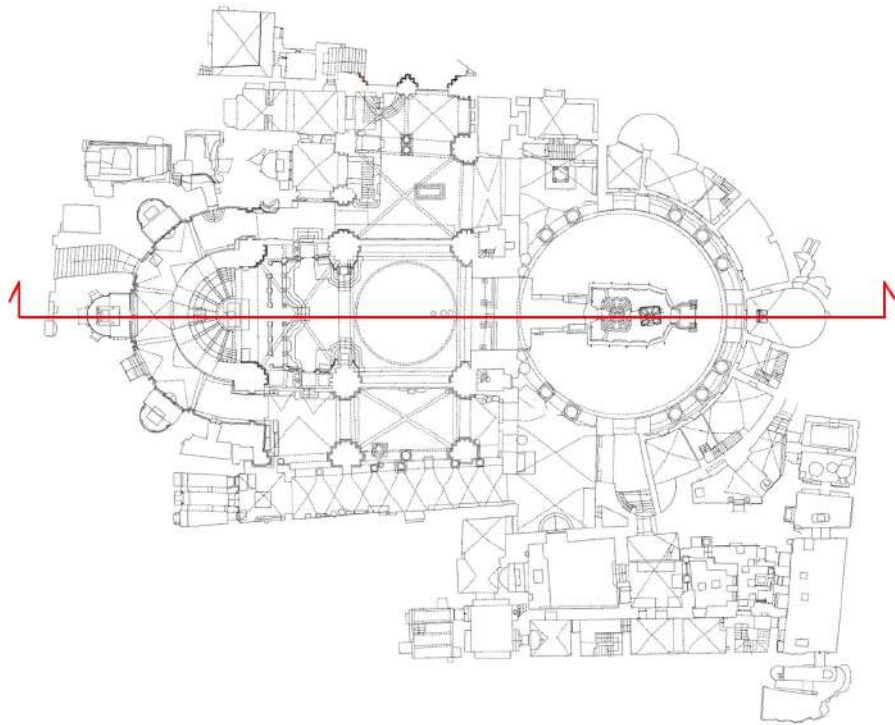
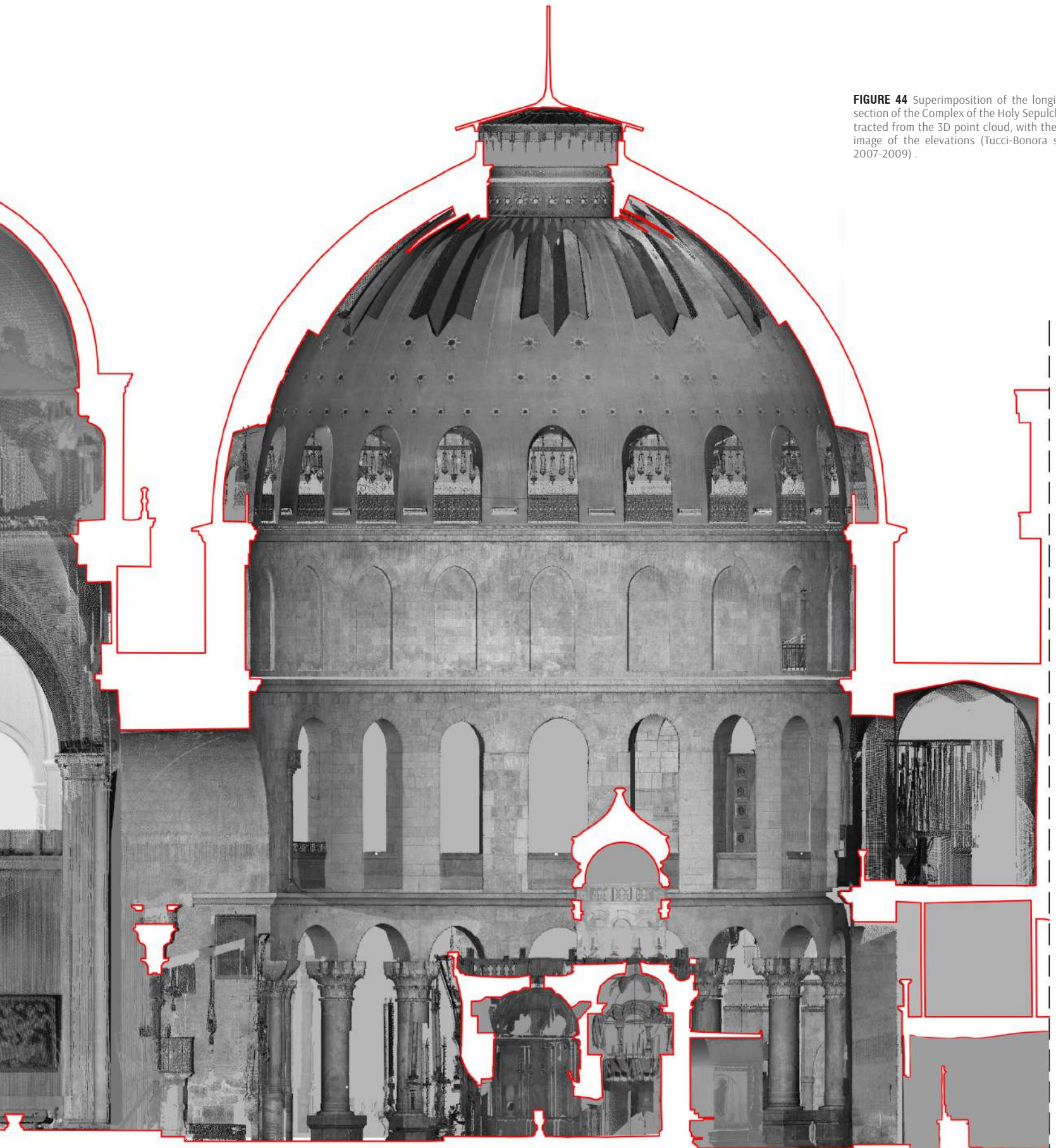

FIGURE 44 Superimposition of the longitudinal section of the Complex of the Holy Sepulchre, extracted from the 3D point cloud, with the orthoimage of the elevations (Tucci-Bonora surveys 2007-2009) .



0 1 2 3 4 5 10m

2007-2010 Grazia Tucci and Valentina Bonora

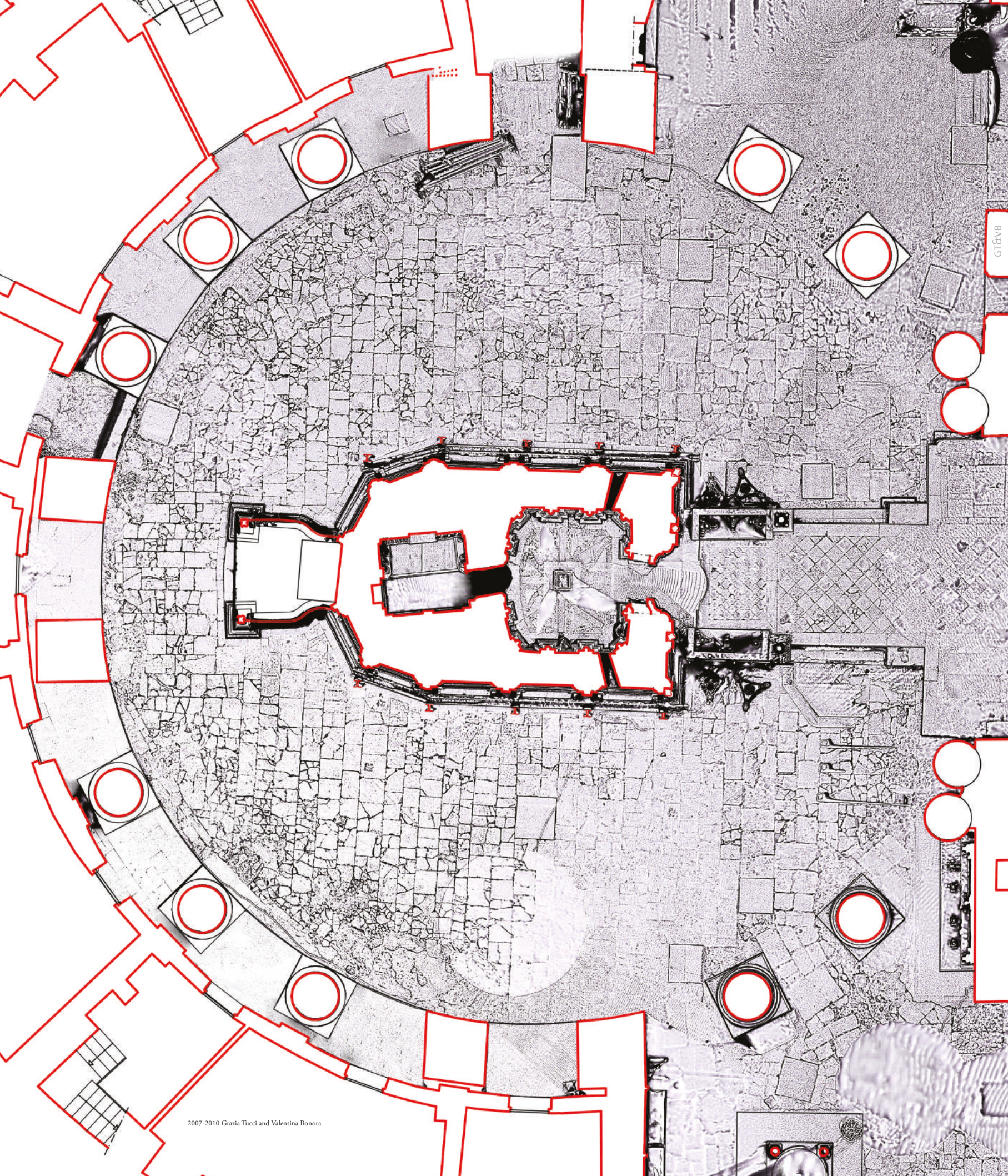
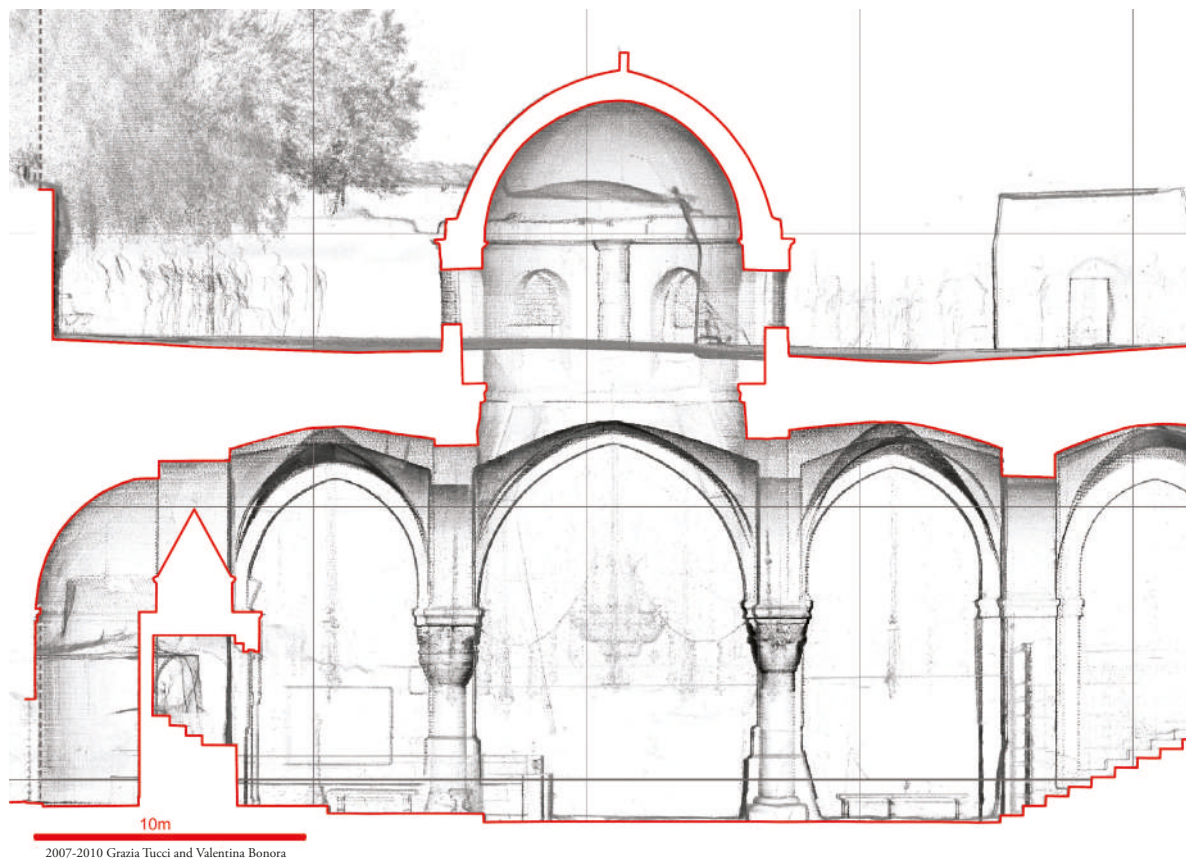
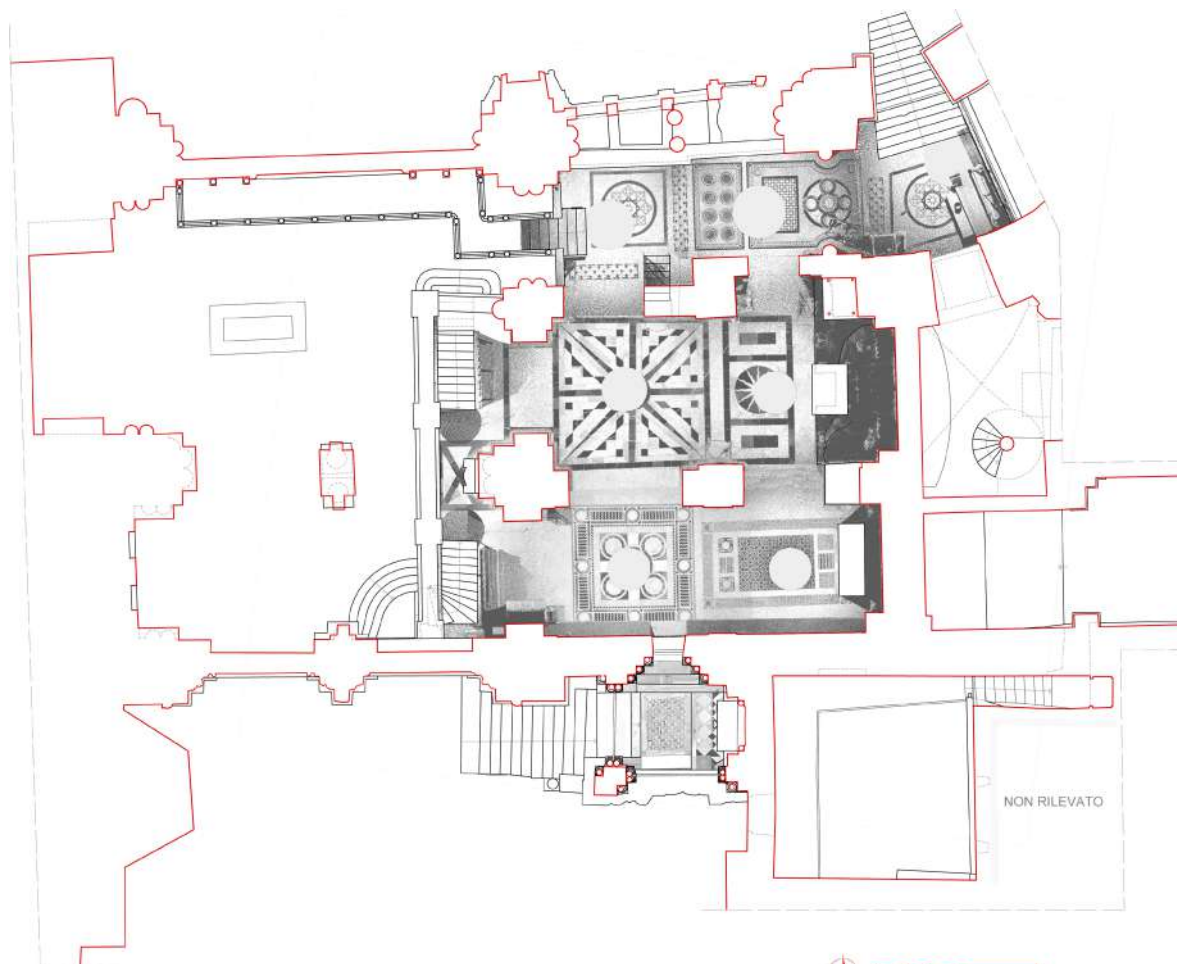

FIGURE 46 Superimposition of the longitudinal section of St. Helena Chapel, extracted from the 3D point cloud, with the orthoimage of the elevations (Tucci-Bonora surveys 2007-2009) .



2007-2010 Grazia Tucci and Valentina Bonora

FIGURE 47 Superimposition of the plan of the 1st floor of the Golgotha, extracted from the 3D point cloud, with the orthoimage of the floor (Tucci-Bonora surveys 2007-2009) .



2007-2010 Grazia Tucci and Valentina Bonora

In the previous page:

FIGURE 45 Superimposition of the plan of the Rotunda, extracted from the 3D point cloud, with the 3D mesh of the floor (Lidia Fiorini from Tucci-Bonora surveys 2007-2009) .

References

- ACHILLE, C., 2003
Tecnologia laser scanner: dal rilievo architettonico alla costruzione del modello, applicazioni, limiti e prospettive, PhD thesis under Carlo Monti, Polytechnic of Milan.
- AMICO, B., 1997
Plans of the sacred edifices of the holy land, Jerusalem, Franciscan Printing Press, Jerusalem.
- ANONYMOUS, 1889
“The Pilgrimage of the Russian Abbot Daniel in the Holy Land (1106-1107)”, in: *Itinéraires russes en Orient*, translated by B. DE KHITROWO, in “Société de l’Orient latin”, sér. Géogr. t. V, Genève.
- BALODIMOS, D., LAVVAS, G., GEORGOPOULOS, A., 2003
“Wholly documenting holy monuments”, in: Proceedings of XIX CIPA Symposium, 30 September - 4 October, Antalya, Turkey.
- BALTSAVIAS, E.P., 1999
“A comparison between photogrammetry and laser scanner”, in *Journal of Photogrammetry and Remote Sensing*, ISPRS, 54(2-3).
- BIDDLE, M., AVNI, G., 2000
La Chiesa del Santo Sepolcro a Gerusalemme, Rcs libri spa, Milan.
- BOEHLER, W., MARBS, A., 2002
“3D scanning instruments”, in: Proceedings of International CIPA Workshop *Scanning for Cultural Heritage recording*, Corfu.
- BOEHLER, W., BORDAS VICENT, M., MARBS, A., 2003
“Investigating laser scanner accuracy”, in: Proceedings of XIXth CIPA Symposium, Antalya, Turkey, 30 September-4 October.
- BOEHLER, W., MARBS, A., 2004
“3D scanning and photogrammetry for heritage recording: a comparison”, in: Proceedings of 12th Conference on *Geoinformatics – Geospatial Information Research: Bridging the Pacific and Atlantic*, University of Gavle, Sweden, 7-9 June.
- BONORA, V., 2005
Dalla nuvola di punti al modello: potenzialità dei sistemi a scansione 3D nel rilievo architettonico. La Cappella Rucellai e il Santo Sepolcro a Firenze, Polytechnic of Turin, Ph.D. Thesis, tutor prof. G. Tucci.
- CAMARDA, M., GUARNIERI, A., MILAN, N., VETTORE, A., 2010
“Health monitoring of complex structure using TLS and photogrammetry”, *International Archives of Photogrammetry, Remote Sensing and Spatial Information Sciences*, Vol. XXXVIII, Part 5 Commission V Symposium, Newcastle upon Tyne.
- CASTAGNETTI, C., BERTACCHINI, E., CAPRA, A., & DUBBINI M., 2012
“Terrestrial Laser Scanning for Preserving Cultural Heritage: Analysis of Geometric Anomalies for Ancient Structures”, FIG Working Week 2012 *Knowing to manage the territory, protect the environment, evaluate the cultural heritage*, Rome, Italy, 6-10 May.
- COOPER, M.A.R., ROBSON, S., 1994
“A hierarchy of photogrammetric records for archaeology and architectural history”, *ISPRS Journal of Photogrammetry and Remote Sensing*, volume 49, issue 5, October 1994, pp. 31-37, [http://dx.doi.org/10.1016/0924-2716\(94\)90022-1](http://dx.doi.org/10.1016/0924-2716(94)90022-1).
- CORBO, V.C., 1982
Il Santo Sepolcro di Gerusalemme, Studium Biblicum Franciscanum, Jerusalem.
- DEQUAL, S., LINGUA, A., 2001
“True Orthophoto for Architectural Surveys”, in: Proceedings of XIX CIPA Symposium, Potsdam.
- ENGLISH HERITAGE, 2011
3D Laser Scanning for Heritage (second edition). Advice and guidance to users on laser scanning in archaeology and architecture, English Heritage Publishing.
- FANGI, G., FIORI, F., GAGLIARDINI, G., MALINVERNI, E.S., 2001
“Fast and accurate close range 3D Modelling by laser scanning system”, in: Proceedings of XIXth CIPA Symposium, Potsdam.
- FORKUO, E.K., KING, B., 2004
“Automatic fusion of photogrammetric imagery and laser scanner point clouds”, in *The International Archives of the Photogrammetry, Remote Sensing and Spatial Information Sciences*, Istanbul.
- GAVITELLI, C., 2003
Storie di modelli espositivi e critici. Modelli storico-critici di rappresentazione oggettuale e di visualizzazione interpretativa, Alinea, Florence.
- GEORGOPOULOS, A., MODATSOS, M., 2002
“Non-metric bird’s eye view”, in: Proceedings of the CIPA WG6 *International Workshop on Scanning for Cultural Heritage Recording*, 1-2 September, Corfu.
- GRAMMATIKOPOULOS, L., KALISPERAKIS, I., KARRAS, G., KOKKINO, T., PETSAS, E., 2004
“Automatic multi-image photo-texturing of 3D surface models obtained with laser scanning”, in: Proceedings of the CIPA International Workshop *Vision techniques applied to the rehabilitation of city centres*, Lisbon.
- GUARNIERI, A., VETTORE, A., EL-HAKIM, S. AND GONZO, L., 2004
“Digital photogrammetry and laser scanning in cultural heritage survey”, in: *International Archives of Photogrammetry and Remote Sensing*, 35(5).

- GUARNIERI A., PIROTTI F., PONTIN M., VETTORE A., 2005
 “Combined 3D surveying techniques for structural analysis Applications”, in: Proceedings of the ISPRS Working group V/4 workshop 3D-ARCH 2005, *Virtual Deconstruction and Visualization of complex Architectures*, Mestre-Venice, 22-24 August.
- IOANNIDES, M., STYLIANIDIS, E., STYLIANOU, S., 2003
 “3D reconstruction and visualization in Cultural Heritage”, in: Proceedings of XIXth CIPA Symposium, Antalya, Turkey, 30 September-4 October.
- JOHANSSON, M., 2002
 “Explorations into the behaviour of three different high-resolution ground-based laser scanners in the built environment”, in: Proceedings of the International CIPA Workshop *Scanning for Cultural Heritage Recording*, Corfu.
- LICHTI, D.D., GORDON, S.J. STEWARD, M.P., FRANKE, J., TASKIRI, M., 2002
 “Comparison of digital photogrammetry and laser scanning”, in: Proceedings of the International Workshop *Scanning for Cultural Heritage recording*, Corfu.
- LICHTI, D.D., LICHT, M.G., 2006
 “Experiences with terrestrial laser scanner modelling and accuracy assessment”, in: *International Archives of Photogrammetry, Remote Sensing and Spatial Information Sciences*, 36 (5), pp. 155-160.
- PATIAS, P., 2006
 “Cultural Heritage Documentation”, http://www.photogrammetry.ethz.ch/summer-school/pdf/15_2_Patias_CHD.pdf.
- PICCIRILLO, M., 2007
La nuova Gerusalemme: artigianato palestinese al servizio dei luoghi santi, Custody of the Holy Land, Jerusalem.
- RAMOS, M.M., REMONDINO, F., 2015
 “Data fusion in Cultural heritage – a review”, in: *The International Archives of the Photogrammetry, Remote Sensing and Spatial Information Sciences*, Volume XL-5/W7, 2015 25th International CIPA Symposium 2015, 31 August – 4 September 2015, Taipei.
- REMONDINO, F., 2003
 “From point cloud to surface: the modeling and visualization problem”, in: *The International Archives of the Photogrammetry, Remote sensing and Spatial Information Sciences*, Vol. XXXIV, Part 5/W10, Istanbul.
- RUTHER, H., 2007
 “Geo-info and Cultural Heritage”, in: *Gim International*, Vol. 21, n. 3.
- SCHUEREMANS, L., VANGENECHTEN, B., 2007
 “The use of 3D-laserscanning in structural restoration projects – a case study on the Church of Sint-Jacobs illustrating the possibilities and limitations”, in: Proceedings of the OPTIMESS 2007 Workshop 28th-30th May, Leuven.
- SCHULZ, T., INGENSAND, H., 2004
 “Terrestrial Laser Scanning – Investigations and Applications for High Precision Scanning”, in: Proceedings of FIG Working Week, Athens, 22-27 May.
- STYLIANIDIS, E., REMONDINO, R., 2016
 3D Recording, Documentation and Management of Cultural Heritage, Whittles Publishing,
- TUCCI, G., BONORA, V., SACERDOTE, F., COSTANTINO, F., OSTUNI, D., 2004
 “From the acquisition to the representation: quality evaluation of a close range model”, in: *The International Archives of the Photogrammetry, Remote Sensing and Spatial Information Sciences*, Istanbul.
- TUCCI G., BONORA V., 2015
 “Geomatics and management of at-risk cultural heritage”, in: *Rendiconti Lincei*, 26, Supplement 1, Springer, 2015, 2037-4631, pp. 105-114, [Online:<http://link.springer.com/article/10.1007%2fs12210-015-0427-0> (12/01/2015)]
- TUCCI G., BONORA V., CONTI A., FIORINI L., 2017
 “High-quality 3D models and their use in a Cultural Heritage conservation project”, in: *The International Archives of the Photogrammetry, Remote Sensing and Spatial Information Sciences*, Volume XLII-2/W5, 2017, 26th International CIPA Symposium 2017, 28 August–01 September 2017, Ottawa, Canada, p.p. 687-693 <https://www.int-arch-photogramm-remote-sens-spatial-inf-sci.net/XLII-2-W5/687/2017/isprs-archives-XLII-2-W5-687-2017.pdf>.
- TUCCI, G., CONTI, A., FIORINI, L., 2018
 “Geomatics for structural assessment and surface diagnostic of CH”, in: XIV International Conference on Building Pathology and Constructions Repair – CINPAR 2018, *Procedia Structural Integrity*, 11, p.p. 2-11, <https://doi.org/10.1016/j.prostr.2018.11.002>.
- TUCCI, G., BARTOLI, G., BETTI, M., 2019
 “TLS Survey and FE Modelling of the Vasari’s Cupola of the Basilica dell’Umiltà (Italy). An Interdisciplinary Approach for Preservation of CH”, In: MOROPOULOU A., KORRES M., GEORGIOPOULOS A., SPYRAKOS C., MOUZAKIS C. (EDS), *Transdisciplinary Multispectral Modeling and Cooperation for the Preservation of Cultural Heritage*, TMM_CH 2018. *Communications in Computer and Information Science*, vol 961. Springer, Cham, p.p. 487-499, 2019 [https://doi.org/10.1007/978-3-030-12957-6_34]
- UNESCO, 2003
 “Charter on the Preservation of Digital Heritage” (http://portal.unesco.org/en/ev.php-URL_ID=17721&URL_DO=DO_TOPIC&URL_SECTION=201.html).

Part two

Chapter III



FIGURE 1 3D mesh of the entrance of the Holy Sepulchre. On the left, the Stone of Anointing; on the right, the "breakneck" (as Corbo used to say) stairs to the Golgotha (L. Fiorini, from point cloud surveyed by Tucci-Bonora).