



UNIVERSITÀ
DEGLI STUDI
FIRENZE

FLORE

Repository istituzionale dell'Università degli Studi di Firenze

AgroBot Smash a Robotic Platform for the Sustainable Precision Agriculture

Questa è la Versione finale referata (Post print/Accepted manuscript) della seguente pubblicazione:

Original Citation:

AgroBot Smash a Robotic Platform for the Sustainable Precision Agriculture / Sarri D.; Lombardo S.; Lisci R.; De Pascale V.; Vieri M.. - ELETTRONICO. - 67:(2020), pp. 793-801. (Innovative Biosystems Engineering for Sustainable Agriculture, Forestry and Food Production) [10.1007/978-3-030-39299-4_85].

Availability:

The webpage <https://hdl.handle.net/2158/1194809> of the repository was last updated on 2020-05-25T13:07:39Z

Publisher:

Springer

Published version:

DOI: 10.1007/978-3-030-39299-4_85

Terms of use:

Open Access

La pubblicazione è resa disponibile sotto le norme e i termini della licenza di deposito, secondo quanto stabilito dalla Policy per l'accesso aperto dell'Università degli Studi di Firenze (<https://www.sba.unifi.it/upload/policy-oa-2016-1.pdf>)

Publisher copyright claim:

La data sopra indicata si riferisce all'ultimo aggiornamento della scheda del Repository FloRe - The above-mentioned date refers to the last update of the record in the Institutional Repository FloRe

(Article begins on next page)

AgroBot Smash a robotic platform for the sustainable precision agriculture

D. Sarri^{1*}, S. Lombardo¹, R. Lisci¹, V. De Pascale¹, M. Vieri¹

¹ Department of Agricultural, Alimentary, Environmental and Forestry sciences DAGRI,
Università degli Studi di Firenze, Piazzale delle Cascine 15, 50144, Firenze (Italy)
daniele.sarri@unifi.it

Abstract The growing need for production processes oriented to environmental sustainability is leading to the quickly spreading of robotic solutions. In this scenario, the Smart Machine for Agricultural Solutions High-tech SMASH project is focusing on the development of a robotic collaborative ecosystem. It consists of four main modules: an unmanned ground vehicle (AgroBot), a soil monitoring unit (Plantoid), an aerial unit (Fly-Bot), and a mobile service unit on the field (AncillaryBot). Furthermore, the SMASH project is implementing technological solutions with a view to resolve some issues related to nutrition safety (e.g. nitrate content on the vegetable) and environmental sustainability (e.g. pesticide use, production process waste) in two representative scenarios of specialty crops (viticulture) and vegetables (spinach). The present work reports the results concerning the design stage and development of the robotic terrestrial platform AgroBot and their implements for the crop protection management and physical control of weeds. A system made of a terrestrial wheeled platform with an innovative perception system and three types of implements have been built to make sustainable agronomic practices.

Keywords: *precision farming, monitoring, viticulture, agricultural robots, automation.*

1 Introduction

In the reference framework of the last 15 years, European institutions, in collaboration with member states and researchers, raised more awareness of the use of pesticides in agriculture. At first, starting from more punctual legislation (EU, 2007) to reduce the use of pesticides, with the aim of opening new markets and promoting environment and citizens' health security. In this path, some of the calls from the projects of Horizon 2020 (RHEA project) (Gonzalez-de-Santos et al., 2016; Vieri et al., 2013), but also some directly founded in regional systems (even through European balance) (i.e. POR CREO – FSE Tuscany) are oriented to find innovative solutions for minimizing agricultural impacts. With those premises, the largest part of robotics applied to agriculture tries to bring an innovative approach and practical solutions for farmers who need to apply pesticides in the safest and more precise way. Not only robots are going to radically change the machinery sector: innovation is actually running in the direction of using fleets of

robots for field operation, instead of tractors. This, if it became real, could mean that abilities in the field, for technicians and farmers, should change too. Currently, there are different kinds of robots, which make different operations but two are the main functioning: only sensing or monitoring and field works. Robots for monitoring are usually able to map and scan the canopy, to estimate the production, to evaluate water content and other parameters by several kinds of sensors. Those particular sensors are better than human eyes and may help in the decision process. Only in the viticulture sector, there are different projects and we cite the most innovative as Vinbot (Vinbot, 2019) and Vinerobot (Saiz-Rubio et al., 2017). Robot for both monitoring and field operations have been mainly developed for one field operation, but they have mounted on a lot of different sensors that help the decision process of the machine (in some cases it is real-time elaboration). Even in the viticulture sector, there are Vitirover (Vitirover, 2019) or Agrirobot (Agrirobot, 2019), a set of sensors (GNSS included) that help the robots decide when and where to cut grass under the single vine. The GNSS helps the robot to be autonomous, but in some cases, it could be beneficial to have the machine guided in remote mode, and for this reason Vitirover has a dedicated app and a platform on PC. There are many other best cases of robots in the viticulture sector, such as the French Wall-YE, which with its sensors and arms can practice precision pruning (Diago & Tardaguila, 2015) . It is also interesting the experience made with the development of Vineguard: its aim, achieved, was to develop a robot able to use variable rate treatments on leaves in the vineyard. SMASH (Smart Machine for Agricultural Solutions High-tech) is a project funded by Tuscany region and its objective is to introduce innovative technologies to realize sustainable agricultural practices to reduce the input needed in terms of products applied. The SMASH Project has the following aims: 1. Creating a robotic collaborative ecosystem. 2. Monitoring and managing modular and integrated systems for sustainable agricultural crops through precision agriculture techniques. In addition, SMASH will try to solve problems related to food security as nitrates concentration and the use of chemicals over crops starting from two study cases on vineyards and spinach cultivation. The robot is going to be a modular tool with a ground mobile unit (AgroBot), a unit devoted to the soil inspection (Plantoide), a flying unit (Flybot) e a unit for field boundaries (AncillaryBot).

2 Material and method

The project development is articulated in two main tasks, i.e. the design of unmanned ground vehicle (AgroBot) and the implements used to perform field activities. This was achieved in four main steps, i.e. (a) definition of technical and functional specification, (b) design, (c) manufacturing, (d) field tests.

2.1 AgroBot system architecture

The AgroBot design followed the overall criterion used for agricultural machines but with particular attention paid to the carrying out of low impact agricultural activities. Therefore, it was chosen to develop an electrical power-driven robot, wheeled, with two axles and light mass to limit the issues of soil compaction. Other design criteria were the ability to maintain stability on the asperities that can be found in specialized and open field cultivation, without losing out on performance in terms of autonomy, load-carrying capacity, tractive power and actuation of certain implements. Further design specification was the capacity to perform both monitoring and execution of some cultural interventions. The last point required the adaptation of variable wheel tracks to the vegetable scenario. This was characterized by a seeding layout of 0.6 m between three rows and 0.2 m on the line used in the farm which held the field test. Finally, the robot should be able to geo-locating and moving independently using dedicated sensors and planning strategies, route and obstacle management based on the latest generation control algorithms. The robot environment and target perception were designed to get a forward-looking view of the crop rows and obstacle avoidance. Another essential design criterion was the communication system. The AgroBot had to be able to collect data and communicate remotely with the AncillaryBot all the data acquired during the working stages. Besides, the AgroBot had the function of carrying the actuation equipment, which consists of physical (mechanical) and chemical tools to destroy weeds or apply pesticide and non-thermal plasma mixture (NTP).

2.2 Implements design specifications

2.2.1 RoboSpray

As regards the RoboSpray design, the main constraint was the development of a spraying system that fulfilled the following requirements:

- Spot spray technique assisted by a vision disease identification system;
- Pulverization by pressure to get the wider spectrum of drops;
- Airflow generator;
- On-demand spraying system; so as not to have a continuous absorption of electric power;
- 12 and 48 Vdc hardware elements power supplies;
- Possibility of the continuous orientation of the diffuser;
- Installation on a robotic arm.

The need to limit drift as much as possible is obtainable with intelligent spraying systems capable of identifying the infection outbreaks and spraying timely. The criterion of orientation versatility of the diffuser is advantageous to ensure a greater number of degrees of freedom and a broad adaptability of the RoboSpray to the different operating scenarios. The RoboSpray must not only spray a specific pesticide but also distribute, in a targeted way to the ground, the ionized water produced by the NTP system with

punctual volumes. Finally, considering the general objective of designing a robot capable of effectively performing some cultivation interventions in a real agricultural context, technical solutions have been chosen to standardize the power supply to the AgroBot energy sources and calculate the components' adsorption to guarantee practicable autonomy.

2.2.2 DiserBot for specialty crops

The weed control management on tree crops was based on the methodology oriented towards the mechanical control of weeds along the row. The weed control in such zones has been chosen as it represents one of the main critical farmers' issues, being a time and energy-consuming work. The weeds in the crop rows determine issues for water competition, induction of a microclimate favorable to the diffusion of the main pests and diseases. The chemical weed control has been excluded as it is not in line with the general objective of the project: identifying innovative robotic solutions for the development of sustainable agriculture. Therefore the choice fell on the type of passive mechanical weeding in consideration of the right compromise regarding sustainability, efficacy, energy requirements and masses.

2.2.3 DiserBot for vegetable

Weed control on the row of open-field vegetable crops was of a passive mechanical type. The advantages are the same as those shown for the specialty crops DiserBot. The equipment had to be able to perform weed control in the seeding row in the early stages of development so as to increase the effectiveness of control. The equipment must be light with an overall mass such that it can be raised at the end of the plots and allow easy turns. Furthermore, the implementation must have adjustments to be able to adapt to the different sowing layouts, soil textures and irregularities of the ploughed soil to guarantee a constant working height.

3 Results and discussion

On the basis of the design methodology followed, a robot was built with a central body connected to four electric drive wheels mounted on a double axel, one rigid and the other oscillating. The solution identified allows to deal with lateral inclinations of $\pm 20^\circ$ guaranteeing stability in the forwarding. In this perspective, it was considered that the AgroBot should be equipped with four independent drive wheels, so as to ensure greater mobility and an ability to perform maneuvers in narrow spaces. This was achieved by drive wheels, which individually provided tractive power and allowed rotations up to 270° . To make the AgroBot applicability as flexible as possible to the different scenarios, a modular structure, was designed. It allowed the mounting of two types of axels

whose size varies according to the scenario. The overall dimensions of the wheel track range from a minimum of 1.144 m for specialty crops scenario and a maximum of 1.800 m for the vegetable, while the length was 1.400 m. The height from the ground for specialty crops scenario was set at 250 mm to guarantee the vehicle greater stability and adaptability on tilled soils or with plant residues and of 500 mm for the horticultural scenario. The final mass of AgroBot was 800 kg including all the equipments and implementation-perception systems. This architecture limited the problems of soil compaction induced by conventional means to a specific pressure value on the ground of 0.35 Kg cm². The maximum operating speed was 6 km h⁻¹ at the maximum permitted gradient of 15%. The central body of the robot consists of a steel frame, where the power supply system for the equipments and handlings were installed. The main components, positioned inside the steel protection frame, for powering and controlling the vehicle, were (a) battery chargers, (b) a battery Management System, (c) motor inverters, (d) battery pack. The theoretical autonomy was variable according to the activity carried out and the operating scenario from a minimum of 4 h to a maximum of 5.5 h. An inertial geo-localization system with GNSS receiver (double-antenna INS-GNSS) allows estimating the position and orientation of the AgroBot.

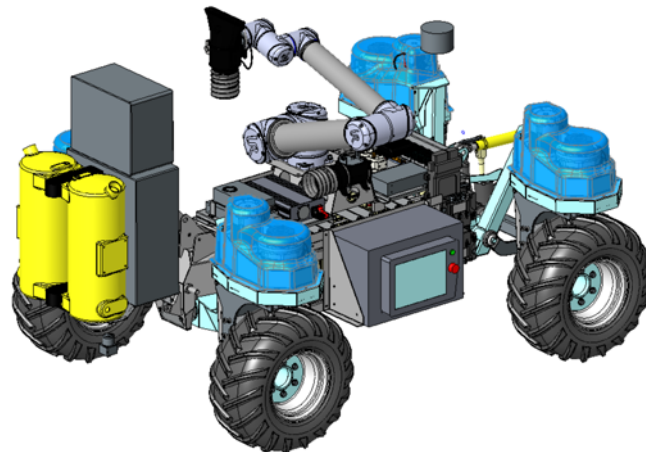

Fig. 1 A general overview of the AgroBot ground unit in the specialty crop version. In the central body, it is possible to view the RoboSpray set up on the robotic arm. On the three hitch point the tank and the electronics.

The localization system is a GNSS-RTK (Real Time Kinematic) with positioning accuracy ± 0.02 m. Navigation takes place based on a georeferenced map of the field on which the main path nodes are loaded. A communication system based on both GPRS-GSM and WiFi technology was implemented in order to transmit all the data acquired during the working stages. The AgroBot have been equipped with a double sensing system. The first, based on vision and laser components, allowed the accident prevention to the plant, humans and animals. The second performed the screening of specific target

(pests on vineyard and weeds on vegetable) through stereo-camera and RGB camera supported by advanced algorithms.

3.1 RoboSpray

The RoboSpray was developed referring to a versatile and controllable pressure system. This combined with a general pressure regulation system, allowed the managing of volumes and the quality of the spray. In the end, RoboSpray presents a sprayer group that permits high configuration in terms of pressure, volumes, and kind of droplet size to use the robot with several pesticides type and crops. This kind of choice is the answer to the need of using the robot for both spraying crop protection products and spraying ionized water. Furthermore, were implemented an electrostatic charging system to increase the droplet deposit and a tool for intermittent spraying (solenoid valve) to modify the liquid flow. RoboSpray parts were a tank (more less 30 L) posed in vertical (to avoid problems connected to the draft of the liquid when transversal and longitudinal slope occur), a filter for impurities, a diaphragm pump 12Vdc able to provide variable continuous pressure and variable flow in relation to the needs, a manual pressure regulator, a standard ISO nozzle manually interchangeable and a solenoid valve for regulating and interrupting the liquid flow. An electrical fan was mounted to direct drops produced by the spraying system. This tool seems to be essential to be able to give a warranty for the correct direction of spray on targets to permit the right penetration inside the canopy and coverage on vegetal elements. For this purpose, an axial turbine with a 48 Vdc electric drive was chosen, with the possibility of being regulated on time in relation to the distance of the target and the thickness of vegetation to be penetrated. To limit pitching problems during the advancement of the robotic platform and in consideration of the need to install RoboSpray on the robotic arm universal robot UR10 hydraulic components (excluding pulverization system and solenoid valve) were positioned on the rear linkage to optimize dell'AgroBot spaces. The turbine, the atomization system, and the solenoid valve were instead set up at the end of the robotic arm. The electrical components are electronically managed and controlled in the different stand-by, idle and working phases to obtain the maximum energy yield and to safeguard as much as possible the energetic autonomy of the terrestrial mobile unit. The whole is assembled as a "kit" to facilitate coupling operations.

3.2 DiserBot: specialty perennial crops

The passive mechanical control was carried out by shaped mechanical tools in neutral mounted on a support arms with a variable inclination with respect to the direction of forward motion. The actuators used were of the star-shaped finger type. These elements exploit the advancement of the vehicle. The resultant forces determine a rotation induced by the advancement of the AgroBot therefore they do not need direct supply and continuous energy for their actuation. The star-shaped finger tools, with their particular

shape, penetrate the ground below the plant and thanks to the steel teeth placed underneath, work the ground superficially (0.05 m). To improve the weed removal action, a double idle toothed steel wheel has been applied at the front which coarsely breaks the soil. A support frame with adjustments to the working and positioning heights was developed to plug the implements to the AgroBot. The star-shaped finger rotor provides for the shredding of the particles in smaller aggregates and the filling of weeds. Based on the existing applications used in the specialty crops scenario, the expected forwarding speed of advancement of the AgroBot (4.5 Km h^{-1}) is compatible with the operation of the identified solution. This peculiarity allowed high autonomy to the terrestrial unit with considerable advantages in terms of performance and work productivity.



Fig. 2 Implements for mechanical weed control (a) on the row on specialty perennial crops and (b) on the row for vegetable crops.

3.3 *DiserBot: vegetable*

The DiserBot weed control on the row of open field vegetable was achieved by passive mechanical equipment. The working elements of this type of operator were composed of opposing rotating metal plates neutral mounted on an axis inclined with respect to the surface of the ground and connected to a mainframe by adjustable arms. The motion of the weed spreader is guaranteed by the resistance offered by the ground during the advancement of the AgroBot towards specific metal spikes, mounted on the lower part of the support plate so as to penetrate for a few centimeters inside the soil. Along the external circumference of the rotating plates are mounted the flexible elements (fingers), made of plastic material so as not to damage the stem of the crop. Furthermore, to adapt to the different sowing layouts and irregularities of the worked soil, a double regulating system was developed. The first is of manual type and consists of a support wheel adjustable in height, the second is of the type with automatic mechanical damping to contain the possible asperities on the transplant bed. The total mass of the tool was 90 kg. This made it possible to use an electric-type linear actuator for lifting on the three-point

hitch. This has made it possible to obtain a compact and light and versatile system that can be raised at the end of the field and allow easy turns. The implements perform weed control for a maximum of three rows in a single passage.

4 Conclusion

In the present study, the result related to the development stage of a robotic platform for sustainable precision agriculture were shown. The ground unit has high performances and innovative operating characteristics among the robotic solutions developed to date. The AgroBot allows both the scouting phase and the execution of cultivation interventions in a precise manner and at a variable rate. This, together with the other modules of the robotic platform, represents an articulated and intelligent system able to offer decision-making and operational support to farmers who can implement agricultural processes with reduced environmental impact.

Acknowledgements The activity presented in the paper is part of the research grant POR CREO FESR Toscana 2014 - 2020 AZIONE 1.1.5 sub azione 11 - RS 2017 Progetti Strategici di ricerca e sviluppo Bando 1 project Smart Machine for Agricultural Solutions High-tech (SMASH) CUP D51B17002350009.

References

- Agrirobot, 2019. Last accessed on 2019 July the 5th <https://ambrogiorobot.weebly.com/agrirobot.html>
- Diago M P and Tardaguila J. 2015. A new robot for vineyard monitoring. *Wine Vitic. J.*; 30(3): 38.
- Gonzalez-de-Santos, P., Ribeiro, A., Fernandez-Quintanilla, C., Lopez-Granados, F., Brandstetter, M., Tomic, S., Pedrazzi, S., Peruzzi, A., Pajares, G., Kaplanis, G., Perez-Ruiz, M., Valero, C., Del Cerro, J., Vieri, M., Rabatel, G., Debilde, B. 2016. Fleets of robots for environmentally-safe pest control in agriculture. *Precision Agriculture*. Pp. 1-41. DOI: 10.1007/s11119-016-9476-3
- Saiz-Rubio, V., Rovira-Más, F., & Millot, C. (2017). Performance improvement of a vineyard robot through its mechanical design. Paper presented at the 2017 ASABE Annual International Meeting, doi:10.13031/aim.201701120
- Vieri, M., Sarri, D., Rimediotti, M., Perria, R., Storchi, P. 2013. The new architecture in the vineyard system management for variable rate technologies and traceability. *Acta Hort.* 978, 47-53. DOI: 10.17660/ActaHortic.2013.978.3
- Vinbot, 2019. Last accessed on 2019 July the 5th <http://vinbot.eu/>
- Vitirover, 2019. Last accessed on 2019 July the 5th <https://www.vitirover.fr/>