



UNIVERSITÀ
DEGLI STUDI
FIRENZE

FLORE

Repository istituzionale dell'Università degli Studi di Firenze

Space-Time MMSE Reception in Multi-Satellite UMTS

Questa è la Versione finale referata (Post print/Accepted manuscript) della seguente pubblicazione:

Original Citation:

Space-Time MMSE Reception in Multi-Satellite UMTS / Mucchi, Lorenzo; Palandri, T.; DEL RE, Enrico; Fantacci, Romano. - STAMPA. - (2003), pp. 1163-1167. (IEEE GLOBECOM 2003 San Francisco 1-5 December) [10.1109/GLOCOM.2003.1258420].

Availability:

The webpage <https://hdl.handle.net/2158/238206> of the repository was last updated on 2018-01-11T13:51:14Z

Publisher:

IEEE

Published version:

DOI: 10.1109/GLOCOM.2003.1258420

Terms of use:

Open Access

La pubblicazione è resa disponibile sotto le norme e i termini della licenza di deposito, secondo quanto stabilito dalla Policy per l'accesso aperto dell'Università degli Studi di Firenze (<https://www.sba.unifi.it/upload/policy-oa-2016-1.pdf>)

Publisher copyright claim:

La data sopra indicata si riferisce all'ultimo aggiornamento della scheda del Repository FloRe - The above-mentioned date refers to the last update of the record in the Institutional Repository FloRe

(Article begins on next page)

Space-Time MMSE Reception in Multi-Satellite UMTS

Lorenzo Mucchi, Tommaso Palandri, Enrico Del Re, Romano Fantacci

University of Florence
Department of Electronics and Telecommunications
via S. Marta, 3 I-50139 Firenze, Italy
Email: mucchi@lenst.det.unifi.it

Abstract—This paper deals with the comparison among two schemes of space-time MMSE reception implemented for the forward link of a WCDMA multi-satellite UMTS environment. The so called space-time transmit diversity technique (STTD) has been coupled with the minimum mean square error (MMSE) interference suppression technique. The idea has come from the realization that the diversity gain is limited by a medium-high level of multiple access interference ([11]). The proposed schemes can be distinguished by the order in which the space-time processing and the MMSE interference suppression are performed. We named *ST-MMSE Pre STTD Combining* if the MMSE filtering is performed before the space-time combining and *ST-MMSE Post STTD Combining* if the interference suppression and the space-time combining are jointly processed. A realistic multi-satellite UMTS environment has been simulated in order to compare the proposed detectors. Bit error rates have been calculated by mean of Monte Carlo simulations assuming a time-varying satellite channel model. Simulations show that the Post-combining scheme gives the best results, but it implies more complexity to the mobile terminal. Anyway, both the proposed ST-MMSE schemes yield significantly better performance than the standard STTD receiver or the conventional RAKE receiver.

I. INTRODUCTION

The role of satellite communications is still not completely clear to the scientific and industrial world, but it is attracting a greater attention as a viable mean to distribute certain services and help in coverage of hard-to-access areas. Due to its large coherence bandwidth, satellite channels do not offer high frequency diversity that is usually exploited in terrestrial CDMA cellular systems through maximal ratio combining (MRC) and RAKE receivers. Therefore, spatial transmit diversity through simultaneous transmissions from two or more satellites jointly covering the cell of interest has gained much interest recently. In most of the developed satellite constellations, there are usually multiple satellites jointly visible to user and gateway, and call can be simultaneously established through two different links - one on each satellite. If one of the links is obstructed the other link can carry the call. Satellite diversity turns out to be fundamental in reducing the signal blockage probability, as it has been confirmed during experimental campaigns whose results are summarized in [9].

Satellite diversity concept is analogous to soft/softer concept in cellular systems, but some differences exist. In the satellite

systems, a user will operate with two or more satellites virtually all its time. Secondly, if the macrodiversity can reduce the capacity of the BS-user terminal link, this fact has much more impact on satellite link where the bottleneck of the capacity is the downlink (satellite-user terminal). Therefore, it is fundamental to exploit as effectively as possible the signal replicas coming from different satellites by using a proper satellite diversity scheme.

Different satellite diversity schemes have been studied and compared in the past [11]. The Space-Time Transmit Diversity [2] technique has been selected as one of the most attractive for its good performance and inherent low complexity of the mobile terminal. It does not require expansion in bandwidth and the feedback from receiver to transmitter is not needed. The decoding algorithm is a simple line processing and the complexity of the receiver will not be increased considerably. Although the STTD technique is originally proposed for narrowband systems, it can be straightforwardly used in WCDMA systems [11]. Unfortunately, such technique has shown poor performance in heavily loaded system [11], i.e., when the multiple access interference (MAI) is high the STTD receiver loses the diversity gain. In order to recover the diversity gain, two approaches are possible: to insert an outer encoder in the receiver [11] or to insert an advanced interference suppression technique. This paper provides the second point although a combination of this two techniques can exploit further advantages. Two basic receivers are here proposed: the ST-MMSE Pre STTD Combining and the ST-MMSE Post STTD Combining. The two schemes differ from the order in which the interference suppression and the space-time processing are performed in the receiver. Firstly, some concepts on transmit diversity developed in a terrestrial synchronous scenario, [2],[3], has been extended to a multi-satellite asynchronous environment. Therefore, the exploitation of the signal coding in space and in time coupled with the MMSE interference suppression is investigated. For this purpose a multi-satellite WCDMA-based environment has been simulated, respecting all the Satellite-UMTS specification [1]. The remainder of this paper laid out as follows. Section II details the system model used to evaluate the performance of the receivers. Section III deals with the multi-satellite environment. The STTD MMSE

receivers are proposed in Section IV. Section V carried out the simulation results and Section VI concludes the paper.

II. SYSTEM MODEL

Let us focus on K WCDMA users sharing the same ground cell. The cell is highlighted contemporaneously by J spots of the N_s satellites in view. Transmission towards the users is performed according to a QPSK Direct-Sequence CDMA basis. The equivalent baseband received signal at the mobile terminal over a stream of N symbols is

$$r(t) = \sum_{s=1}^{N_s} \sum_{k=1}^K \sum_{j=1}^J A_{k,j,s} \sum_{n=0}^{N-1} b_{k,j,s}^{(n)} \sum_{l=1}^L c_{k,j,l,s}^{(n)} s_{k,j,s}^{(n)}(t - nT - \tau_{k,j,s,l}) + n(t) \quad (1)$$

where $A_{k,j,s}$ is the received signal amplitude for the k -th user s -th satellite j -th antenna, $b_{k,j,s}^{(n)}$ is the transmitted bit in the n -th symbol interval from the s -th satellite and the j -th antenna, $c_{k,j,l,s}^{(n)}$ are the channel complex coefficients including carrier phase, $\tau_{k,j,s,l}$ is the l -th path delay from the j -th antenna of the s -th satellite for user k and $n(t)$ is the noise signal. The term $s_{k,j,s}^{(n)}(t) = \sum_{g=1}^G s_{k,j,s}^{(n)}(g)p(t - gT_c)$ represents the spreading waveform for the n -th symbol where T is the symbol interval, T_c is the chip interval, $p(t)$ represents the chip waveform due to pulse shaping filter and $s_{k,l}^{(n)}(g)$ is the code referred to the n -th symbol interval. This code is a combination of channelization and scrambling codes $s_{k,l}^{(n)}(g) = s_{k,l}^{[ch]}(g)s_{k,l}^{[sc]}(g + (n \bmod (H/G))G)$, where G is the spreading factor and H is the length of the scrambling code [10]. A single-path transmission ($L = 1$) has been here considered since both the near and the far echoes (lower replicas of the transmitted signal) power is at least 15 dB below the first path and hence there is no visible advantage in detecting them [4].

Several satellite channel models has been proposed in the last years and a comparison among them is presented in [5]. The results shown in this paper are obtained using the so called *Corazza's model* [6].

At the receiver, the signal (1) is first passed through a chip matched filter and sampled at the chip time. By using a matrix notation, the discrete output of the chip matched filter and sampler is:

$$\mathbf{r} = \mathbf{S}_1 \mathbf{C}_1 \mathbf{A}_1 \mathbf{b}_1 + \mathbf{S}_2 \mathbf{C}_2 \mathbf{A}_2 \mathbf{b}_2 + \mathbf{n} \quad (2)$$

where

- the subscript (1,2) refers to different satellites,
- the vector $\mathbf{r} = [r(0), r(T_s), \dots, r((N+V)SG - 1)T_s]^T \in \mathcal{C}^{(N+V)SG}$ is the input sample vector,
- T_s is the sample time,
- N is the number of symbols in the receiver observation interval,
- S is the number of samples per chip,
- G is the spreading factor,
- $V = \lceil [\max_{k,j,l} \{\tau_{k,j,l}\} + (P-S)T_s] / T^1 \rceil$ is the maximum delay spread due to the satellite transmission, channel multipath and pulse shaping filter,
- P is the shaping filter impulse response length,
- T is the symbol interval,

- $\mathbf{S} = [\mathbf{S}^{(0)}, \mathbf{S}^{(1)}, \dots, \mathbf{S}^{(N-1)}] \in \mathcal{C}^{(N+V)SG \times NKJL}$ denotes the sample spreading sequence matrix with:

$$\mathbf{S}^{(n)} = [\mathbf{S}_{(1)}^{(n)}, \mathbf{S}_{(2)}^{(n)}, \dots, \mathbf{S}_{(K)}^{(n)}] \in \mathcal{C}^{(N+V)SG \times KJL},$$

$$\mathbf{S}_k^{(n)} = [\mathbf{S}_{(k,1)}^{(n)}, \mathbf{S}_{(k,2)}^{(n)}, \dots, \mathbf{S}_{(k,J)}^{(n)}] \in \mathcal{C}^{(N+V)SG \times JL},$$

$$\mathbf{S}_{k,j}^{(n)} = [s_{k,j,1}^{(n)}, s_{k,j,2}^{(n)}, \dots, s_{k,j,l}^{(n)}] \in \mathcal{C}^{(N+V)SG \times L},$$
 where $s_{k,j,l}^{(n)}$ is the spreading sequence of the k -th user, l -th path, j -th transmitting antenna, in the n -th symbol interval, given by

$$\begin{bmatrix} \mathbf{0}_{(nSG + \tau_{k,j,l}) \times 1} \\ \mathbf{s}_{k,j}^n \\ \mathbf{0}_{[(N-1+V-n)SG - P + S - \tau_{k,j,l}] \times 1} \end{bmatrix} \in \mathcal{C}^{(N+V)SG \times 1},$$

$$\mathbf{s}_{k,j}^n$$
 is the sampled spreading waveform of the k -th user j -th transmitting antenna in the n -th symbol interval, $\mathbf{s}_{k,j}^n = [s_{k,j}^n(0), s_{k,j}^n(T_s), \dots, s_{k,j}^n((SG+P-S-1)T_s)]^T \in \mathcal{C}^{SG+P-S}$;
- $\mathbf{C} = \text{diag}[\mathbf{C}^{(0)}, \mathbf{C}^{(1)}, \dots, \mathbf{C}^{(N-1)}] \in \mathcal{C}^{NKJL \times NKJ}$, is the channel response matrix with:

$$\mathbf{C}^n = \text{diag}[\mathbf{C}_1^{(n)}, \mathbf{C}_2^{(n)}, \dots, \mathbf{C}_K^{(n)}] \in \mathcal{C}^{KJL \times KJ},$$

$$\mathbf{C}_k^n = \text{diag}[\mathbf{c}_{k,1}^{(n)}, \mathbf{c}_{k,2}^{(n)}, \dots, \mathbf{c}_{k,J}^{(n)}] \in \mathcal{C}^{JL \times J},$$

$$\mathbf{c}_k^n = [c_{k,j,1}^{(n)}, c_{k,j,2}^{(n)}, \dots, c_{k,j,L}^{(n)}]^T \in \mathcal{C}^L,$$
 where $c_{k,j,l}^{(n)}$ is the complex channel gain of the l -th path, j -th transmitting antenna for the user k ;
- $\mathbf{A} = \text{diag}[\mathbf{A}^{(0)}, \mathbf{A}^{(1)}, \dots, \mathbf{A}^{(N-1)}] \in \mathfrak{R}^{NKJ \times NKJ}$, is the user transmitting amplitudes matrix with:

$$\mathbf{A}^n = \text{diag}[\mathbf{A}_1^{(n)}, \mathbf{A}_2^{(n)}, \dots, \mathbf{A}_K^{(n)}] \in \mathfrak{R}^{KJ \times KJ},$$

$$\mathbf{A}_k^n = \text{diag}[\mathbf{A}_{k,1}, \mathbf{A}_{k,2}, \dots, \mathbf{A}_{k,J}] \in \mathfrak{R}^{J \times J};$$
- $\mathbf{b} = [\mathbf{b}^{(0)}, \mathbf{b}^{(1)}, \dots, \mathbf{b}^{(N-1)}] \in \Xi^{NKJ}$, is the users data vector with modulation symbol alphabet Ξ and

$$\mathbf{b}^n = [\mathbf{b}_1^{(n)}, \mathbf{b}_2^{(n)}, \dots, \mathbf{b}_K^{(n)}] \in \Xi^{KJ},$$

$$\mathbf{b}_k^n = [\mathbf{b}_{k,1}, \mathbf{b}_{k,2}, \dots, \mathbf{b}_{k,J}] \in \Xi^J,$$
 where $b_{k,j}^{(n)}$ is the k -th user n -th symbol from the j -th transmitting antenna;
- $\mathbf{n} = [n(0), n(T_s), \dots, n([(N+V)SG - 1]T_s)]^T \in \mathcal{C}^{(N+V)SG}$, is the additive white Gaussian noise vector with variance σ_n^2 .

III. THE MULTI-SATELLITE ENVIRONMENT

The multi-satellite scenario considered in this paper is detailed [4]. The S-UMTS environment provides N_s satellite covering the same ground area and each satellite generates J beams towards the earth surface. In order to provide soft-handoff and diversity, each spot beam reuses the same carrier frequency. The forward link assumes the direct transmission from the satellites to the mobile station (MS), while for the reverse link a gateway station (GS) is required, since the MS itself has not enough power to cover that huge distance.

The insertion of a space-time transmit diversity using space-time block codes (STBC) coupled with a MMSE interference suppression technique in a multi-satellite environment is here analyzed. The principle of the space-time transmit diversity technique is to perform a transmission through two different satellites permuting the signal in space and time [2]. After the space-time processing, at the receiver end, the diversity gain is obtained, i.e., an improvement of the spectral efficiency or a higher capacity of the cell. Unfortunately, the diversity gain

is lost if the multiple access interference level is high [11]. For this reason a MMSE filtering has been coupled with the space-time processing.

In this paper, a multi-satellite UMTS system with two satellites covering the same ground cell has been considered. Following the S-UMTS proposal [1], each satellite has its own scrambling code while the same set of channelization codes can be reused by all satellites. Hadamard-Walsh codes of length 32 have been considered for the spreading of the user signals while the satellite scrambling codes have been selected in a family of 256 Gold-like codes. Different cell loads and different mobile terminal velocity (pedestrian and vehicular) have been considered in the simulations.

IV. STTD LMMSE RECEIVERS

In this section two different space-time linear MMSE detectors are derived. The general optimization criterion of a generic linear MMSE receiver can be written as:

$$\min_{\mathbf{w}} \{E(|B - \hat{B}|^2)\} \quad (3)$$

where $\hat{B} = \mathbf{w}^H \mathbf{r}$ is the term that has to be estimated, \mathbf{w} is the filter coefficients vector, \mathbf{r} is the received signal vector, B is the known term who regards to the minimization of the functional and H represents the conjugate-transpose operation. It can be stated that \mathbf{w} depend on the instantaneous fading of different users, mobile terminal velocity, satellites elevation angles and the current SNR. In some early works the basic idea of this type of detector was introduced, [8]. In this paper two different space-time LMMSE receiver schemes are derived depending on the order the space-time processing and the MMSE interference suppression is performed. The two detectors are then compared in terms of performance and complexity to find out which is the best ordering.

A. MMSE Pre STTD Combining

The first scheme provides the MMSE interference suppression previously the STTD combining and it is named *MMSE Pre STTD* receiver. Two independent filters (one for each satellite received signal) are needed. The cost functions to be minimized for the user k are:

$$MSE_{k,1}(i) = E\{|\mathbf{w}_{k,1}^H(i)c_{i,1}^* \mathbf{r}_{i,1} - |c_{i,1}|^2 b_{k,i,1} + c_{i,2}c_{i,1}^* \mathbf{s}_{k,1}^H \mathbf{s}'_{k,2} b_{k,i,2}|^2\} \quad (4)$$

for the Satellite 1 and

$$MSE_{k,2}(i) = E\{|\mathbf{w}_{k,2}^H(i)c_{i,2}^* \mathbf{r}_{i,2} - |c_{i,2}|^2 b_{k,i,2} + c_{i,1}c_{i,2}^* \mathbf{s}_{k,2}^H \mathbf{s}'_{k,1} b_{k,i,1}|^2\} \quad (5)$$

for the signal coming from Satellite 2.

The vector $\mathbf{r}_{i,j}$ is the received signal from the j th satellite in the i th symbol interval, $c_{i,j}$ represents the complex channel gain, $b_{k,i,j}$ is the transmitted symbol according to the well-known Alamouti scheme [2], $\mathbf{w}_{k,j}(i)$ represents the STTD MMSE filter vector dedicated to the detection of the k th user transmission from the j th satellite and $\mathbf{s}_{k,j} \in \mathcal{C}^{SG+P-S}$ is the resulting sequences from the multiplication of the scrambling

and the channelization codes. Let us suppose, without loss of generality, that $\tau_{k,1} < \tau_{k,2}^2$, then

$$\mathbf{s}'_{k,1} = [s_{k,1}(\tau_{k,1}), \dots, s_{k,1}(SG + P - S - 1)T_s, 0, \dots, 0]$$

is the user k code sequence from the Satellite 1 received by the MMSE filter dedicated to the detection of the signal coming from satellite 2,

$$\mathbf{s}'_{k,2} = [0, \dots, 0, s_{k,2}(\tau_{k,2}), \dots, s_{k,2}(SG + P - S - 1)T_s]$$

is the user k code sequence from the Satellite 2 received by the MMSE filter dedicated to the detection of the signal coming from satellite 1. The signals from the two satellites are here supposed asynchronous, hence a generalization of the standard Alamouti [2] decoding rule was considered [12]. In particular it is worth to note that in the asynchronous case the same STTD decoding rule can be used by the fact that $c_{i,2}c_{i,1}^* \mathbf{s}_{k,1}^H \mathbf{s}'_{k,2} = [c_{i,1}c_{i,2}^* \mathbf{s}_{k,2}^H \mathbf{s}'_{k,1}]^*$, i.e., the mutual interference introduced by the symbol ST coding scheme is erased in the ST recombining process at the receiver.

After the filtering (4, 5), the space-time processing is performed in order to get the diversity advantage. The decoder has to take into account two consecutive received symbols

$$\begin{aligned} M_{k,1}(i) &= \mathbf{w}_{k,1}^H(i)c_{i,1}^* \mathbf{r}_{i,1} + \left[\mathbf{w}_{k,2}^H(i)c_{i,2}^* \mathbf{r}_{i+1,2} \right]^* \\ M_{k,2}(i) &= - \left[\mathbf{w}_{k,2}^H(i)c_{i,2}^* \mathbf{r}_{i,2} \right]^* + \mathbf{w}_{k,2}^H(i)c_{i,2}^* \mathbf{r}_{i+1,1} \end{aligned} \quad (6)$$

The last two terms in (4) and (5) represent the part that has not to be modified by the MMSE filter in order to perform exactly the successive space-time processing (6). By inserting in the reference signal of the MMSE cost function what has to be preserved for the successive space-time decoder a full diversity gain can be reached. If the two MMSE filters would be able to ideally remove all the interference, after the filtering Eq. (6) would be :

$$\begin{aligned} M_{k,1}(i) &= (|c_{i,1}|^2 + |c_{i,2}|^2)b_{k,i} \\ M_{k,2}(i) &= (|c_{i,1}|^2 + |c_{i,2}|^2)b_{k,i+1} \end{aligned} \quad (7)$$

and the diversity order of 2 is obtained at the receiver.

The filter vectors $\mathbf{w}_{k,1}$ and $\mathbf{w}_{k,2}$ can be computed using the normalized stochastic gradient algorithm (NLMS) :

$$\mathbf{w}_{k,j}(i) = \mathbf{w}_{k,j}(i-1) - \frac{\mu}{\|\mathbf{r}_{i-1,j}\|^2} \nabla(MSE_{k,j}(i-1)), k = 1, 2, \quad (8)$$

B. MMSE Post STTD Combining

Differently from the STTD Pre MMSE receiver where an MMSE filtering has to be settled for each satellite transmitted signal, in the STTD Post MMSE scheme the space-time processing and the MMSE interference suppression are jointly performed. In such a case only a single filter is needed, but the filter has to take into account of the two consecutive received symbols separately. It can be said that here the MMSE

² $\tau_{k,j}$ is the discrete time delay of the k th user transmission from the j th satellite.

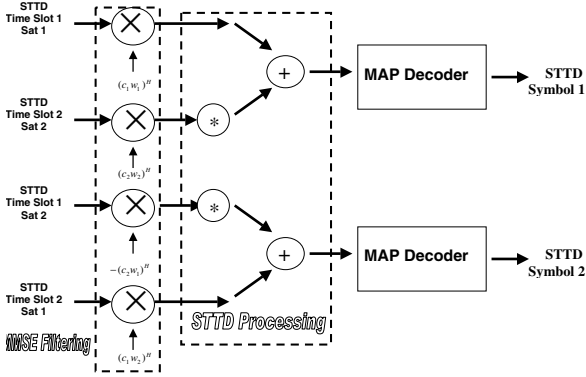

Fig. 1. The LMMSE Pre STTD Combining receiver scheme

filters are "Time-divided", while in the STTD Pre MMSE were "Space-divided". Let us define the vertical concatenation of the two vectors

$$\mathbf{r}_{eq}^{(1)}(i) = \begin{bmatrix} \mathbf{r}_{i,1}^* c_{i,1}^* \\ \mathbf{r}_{i+1,2}^* c_{i+1,2}^* \end{bmatrix} \quad (9)$$

$$\mathbf{r}_{eq}^{(2)}(i) = \begin{bmatrix} -\mathbf{r}_{i,2}^* c_{i,2}^* \\ \mathbf{r}_{i+1,1}^* c_{i+1,1}^* \end{bmatrix} \quad (10)$$

with $i = 0, 2, 4, \dots$. This operation equals to group the received symbols two-by-two.

The MMSE filter of the post-combining scheme has to minimized the following cost functions:

$$MSE_k^{(1)}(i) = E\{|\mathbf{w}_k^{(1)H}(i)\mathbf{r}_{eq}^{(1)}(i) - (|c_{i,1}|^2 + |c_{i,2}|^2)b_{k,i,1}|\}^2 \quad (11)$$

$$MSE_k^{(2)}(i) = E\{|\mathbf{w}_k^{(2)H}(i)\mathbf{r}_{eq}^{(2)}(i) - (|c_{i,1}|^2 + |c_{i,2}|^2)b_{k,i+1,1}|\}^2 \quad (12)$$

where $\mathbf{w}_k^{(p)}$ indicates simply the filter that acts on the received vector $\mathbf{r}_{eq}^{(p)}$ and the index i indicates the i th STTD observation window of two consecutive received symbols.

We have assumed here that $c_{i,1} \approx c_{i+1,1}$ and $c_{i,2} \approx c_{i+1,2}$. This is a mild assumption in the context we are studying because the channel shows a coherent bandwidth longer than two symbol intervals.

The decision variables are hence:

$$M_k^{(1)}(i) = \mathbf{w}_k^{(1)H}(i)\mathbf{r}_{eq}^{(1)}(i) \quad (13)$$

with regards of the transmitted symbol $b_{k,i}$,

$$M_k^{(2)}(i) = \mathbf{w}_k^{(2)H}(i)\mathbf{r}_{eq}^{(2)}(i) \quad (14)$$

with regards of the transmitted symbol $b_{k,i+1}$. The final symbol decision is based on the standard MAP criterium. The decision metrics (13,14) are computed every two symbols and the filter tap weights are updated by using the normalized

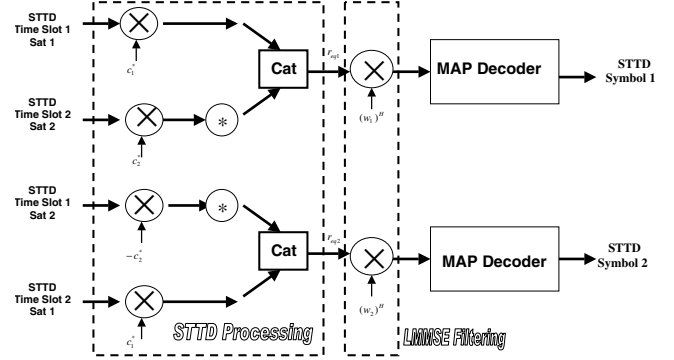

Fig. 2. The LMMSE Post STTD Combining receiver scheme

Parameter	Symbol	Value
Chip rate		3.840 Mc/s
Symbol rate		120 ks/s
Modulation		QPSK
Spreading factor	G	32
Percentage of load assumed		31.25% or 62.5%
Number of samples per chip	S	4
Pulse shape roll-off factor	β	0.22
Pulse length in chips		5
Carrier frequency	f_c	2 GHz
Channel fading model		Corazza
Slow fading bandwidth		6 Hz
Doppler power spectrum		Flat
Speed of MS	v	3Km/h (pedestrian) or 50Km/h (vehicular)
Number of satellites	N_s	2
Number of spot beams per satellite	N_b	3
Channelization code		Orthogonal Gold 32
Scrambling code		Hadamard Walsh 32

TABLE I

PARAMETERS OF THE SYSTEM USED IN SIMULATIONS

LMS algorithm. The MMSE Post STTD receiver exhibits a better performance than the Pre-combining scheme but it has a higher complexity.

V. SIMULATION RESULTS

A multi-satellite environment with two satellites contemporaneously in view has been considered; this is a practical average case because in satellite constellations like Globalstar [7], the contemporary presence of 3 or 4 satellites in visibility can be assumed, although in a smaller percentage of time.

The elevation angles of the satellites have been set both to 55° . An asynchronous downlink WCDMA system in accordance with the model proposed in [10] is considered with two different cell loads (10 and 20 users) and two different mobile terminal speed (pedestrian $3km/h$ and vehicular $50km/h$). Several Montecarlo simulations have been carried on according to the parameters shown in Table I.

The Bit Error Rate of the proposed STTD MMSE receivers, the standard STTD receiver and the conventional RAKE receiver have been compared. The total number of transmitted symbols per simulation has been set to 100000. An 800 symbols training sequence has been considered for

what concern the MMSE STTD receivers at the beginning of the simulation and then a decision direct scheme is used; the training period is set to be repeated every 10000 symbols. The simulation results are shown in figs.3–6.

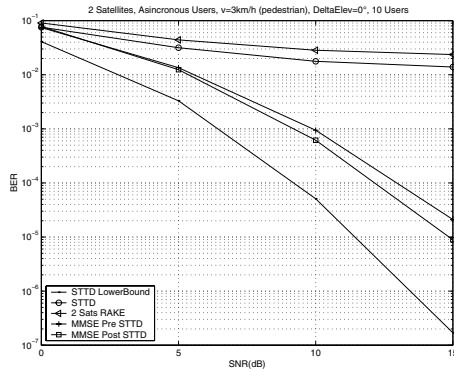

Fig. 3. BER versus E_b/N_0 for QPSK dual Satellite system, 31.25% load, pedestrian

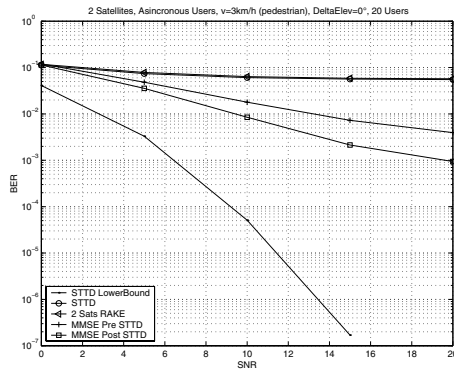

Fig. 4. BER versus E_b/N_0 for QPSK dual Satellite system, 62.5% load, pedestrian

The results show that for a system with more than 10 users (31.25 percent of cell load) transmitting at the same time, the performance of the conventional RAKE and the standard STTD receivers are quite poor while both the STTD MMSE receivers are able to significantly improve the system performance. In the heavily loaded cell case the gain margin over standard receivers is more appreciable, as the SNR increases. This improvement is because the proposed schemes are able to jointly suppress MAI and take advantage of the transmit diversity. Also the particular cost functions of the two receivers derived herein exhibit a remarkable stability of the minimum BER achievable regardless of the mobile terminal velocity. It can be noticed that the MMSE Post STTD receiver has shown a remarkable gain over the MMSE Pre STTD in every operating condition, but it has a higher computational complexity. Anyway, both the ST-MMSE schemes here proposed overcome the classical Rake and STTD receivers.

REFERENCES

[1] ETSI TS 101 851-x, "Satellite Component of UMTS/IMT2000; A-family (S-UMTS-A 25.21x)".

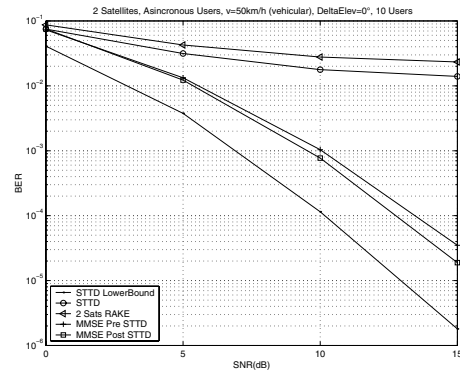

Fig. 5. BER versus E_b/N_0 for QPSK dual Satellite system, 31.25% load, vehicular

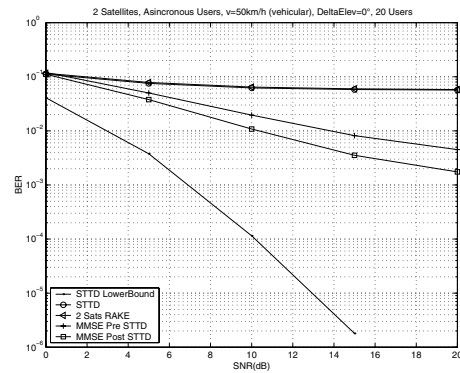

Fig. 6. BER versus E_b/N_0 for QPSK dual Satellite system, 62.5% load, vehicular

[2] S.M. Alamouti, "A Simple Transmit Diversity Technique for Wireless Communications," *IEEE JSAC*, Vol. 16, No. 8, October 1998.

[3] A. Hottinen, R. Wichman, "Transmit diversity by antenna selection in CDMA downlink," *IEEE 5th Int. Symp. on Spread Spectrum Techniques and Applications*, Vol. 3, 1998.

[4] R. De Gaudenzi, F. Giannetti, "DS-SS-CDMA Satellite Diversity Reception for Personal Satellite Communication: Satellite-to-Mobile Link Performance Analysis," *IEEE Trans. on Vehic. Tech.*, Vol. 47, No. 2, May 1998.

[5] A. Mehrnia, H. Hashemi, "Mobile Satellite Propagation Channel – Part 1 – A Comparative Evaluation of Current Models," *IEEE Conf. on Vehic. Tech. VTC '99*, 1999.

[6] G.E. Corazza, F. Vatalaro, "A Statistical Model for a Land Mobile Satellite Channels and its Application to Nonstationary Orbit Systems," *IEEE Trans. on Vehic. Tech.*, Vol. 43, N. 3, August 1995.

[7] F.J. Dietrich, P. Metzzen, P. Monte, "The Globalstar cellular satellite system," *IEEE Trans. on Antennas and Propagation*, Vol. 46, No. 6, June 1998.

[8] Ian Oppermann, "CDMA Space-Time Coding Using An LMMSE Receiver," *IEEE Communication Theory Mini-Conference*, , 1999.

[9] Y. Karasawa, et al., "Analysis of Availability Improvement in LMSS by Means of Satellite Diversity Based on Three-State Propagation Channel Model," *IEEE Trans. on Vehic. Tech.*, , Nov. 1997.

[10] D. Boudreau, G. Caire, G.E. Corazza, R. de Gaudenzi, G. Gallinaro, M. Luglio, R. Lyons, J. Romero-Garcia, A. Vernucci, H. Widmer, "Wide-Band CDMA for the UMTS/IMT-2000 Satellite Component," *IEEE Trans. on Vehic. Tech.*, Vol. 51, No. 2, March 2002.

[11] L. Mucchi, R. Tesi, D. Tujković, E. Kunnari, "Space-Time Coded Transmit Diversity in Multi-Satellite UMTS," *WPMC 2002 Conf. proceedings*, 27-30 October 2002, Honolulu, Hawaii.

[12] T. Palandri, "Space-Time Transmit Diversity and MMSE interference suppression in multi-satellite UMTS," *Master Thesis, University of Florence Press*, November 2002.