



UNIVERSITÀ
DEGLI STUDI
FIRENZE

FLORE

Repository istituzionale dell'Università degli Studi di Firenze

Some innovative readily applicable proposals for chemical separation and sequestration of CO₂ emissions from powerplants

Questa è la Versione finale referata (Post print/Accepted manuscript) della seguente pubblicazione:

Original Citation:

Some innovative readily applicable proposals for chemical separation and sequestration of CO₂ emissions from powerplants / D. FIASCHI; G. MANFRIDA; M. MASSINI; G. PELLEGRINI. - STAMPA. - (2004), pp. 1-7. (7th Biennial ASME ESDA Conference Manchester, UK July 19-22, 2004).

Availability:

The webpage <https://hdl.handle.net/2158/238772> of the repository was last updated on

Publisher:

ASME

Terms of use:

Open Access

La pubblicazione è resa disponibile sotto le norme e i termini della licenza di deposito, secondo quanto stabilito dalla Policy per l'accesso aperto dell'Università degli Studi di Firenze (<https://www.sba.unifi.it/upload/policy-oa-2016-1.pdf>)

Publisher copyright claim:

La data sopra indicata si riferisce all'ultimo aggiornamento della scheda del Repository FloRe - The above-mentioned date refers to the last update of the record in the Institutional Repository FloRe

(Article begins on next page)

ESDA2004-58508

SOME INNOVATIVE READILY APPLICABLE PROPOSALS FOR CHEMICAL SEPARATION AND SEQUESTRATION OF CO₂ EMISSIONS FROM POWERPLANTS

Daniele Fiaschi, Giampaolo Manfrida, Michela Massini and Giacomo Pellegrini

Dipartimento di Energetica "Sergio Stecco"
University of Florence
Via Santa Marta, 3 – 50139 FIRENZE – ITALY
Tel. +39 055 4796436
Fax. +39 055 4796342
E – mail: danif@de.unifi.it

ABSTRACT

The goal of the present manuscript is the investigation of two novel systems for partial CO₂ capture from the exhausts of fossil fuelled powerplants. These systems should be relatively cheap and easily applicable to existing powerplants with minor modification, in order to make them accessible by a large range of users and favour a significant diffusion of partial CO₂ sequestration.

Two basic processes were proposed:

1. Absorption with a liquid solution of water and NH₃;
2. Absorber/desorber system with a liquid solution of water and phosphates.

In the first one, the exhausts react into an absorber column with a liquid sorbent, which is a solution of water and ammonia. The process sequesters the CO₂ in carbamate and bicarbonate and the final product are salt of ammonia, i.e. ammonium carboamate (NH₄HCO₃) and ammonium bicarbonate (NH₄NH₂COO). The outgoing streams of this process are the exhaust gas with a reduced content of CO₂ and a secondary product formed by salts of ammonium, which have an interesting market potential as fertilizers. The obtained CO₂ reduction level was more than 40%, while the amount of secondary products is high enough to get it marketable.

In the second process, the exhausts passing through an absorber column react with a liquid sorbent, which is a solution of water and sodium (or potassium) phosphate. The process sequesters the CO₂ in bicarbonate ions by means of the ions phosphate and the outlet stream is a solution of water and phosphate and carbonate ions. This stream is collected in a desorbing column, where the phosphate ions are almost completely regenerated. The CO₂ reduction level is always higher than 20% and it can

also reach very high values, depending on the parameters of process.

INTRODUCTION

Several ways of integrating gas turbine based powerplants with extensive CO₂ capture systems have been investigated in the last years, especially after the Kyoto Protocol subscription. Generally, these systems are aimed to capture and dispose 80% + of carbon dioxide emissions by the means of upstream fuel decarbonisation technologies [1 – 7] or CO₂ concentrated exhausts cleaning [8 – 10]. In any case, these proposals often imply some changes, which sometimes may be relevant and expensive [10], in the components of the machines and on their working conditions (mainly due to the need of increasing the typically low CO₂ concentration of gas turbines exhausts). Even in the simplest CO₂ reduction oriented powerplant configurations (like semi closed gas turbine SCGT), the cost of electricity is raised around 60 – 70% with respect to traditional configurations with no CO₂ removal [12, 13]. It obviously represents a drawback for power industry to make investments in the direction of greenhouse friendly powerplants. Moreover, transportation and storage of liquid compressed CO₂ still has several unknowns, in terms of costs and environmental safety [14].

In order to encourage the application of low expensive and relatively simple systems for carbon dioxide concentration and storage, a valuable way might be that of not aiming to capture the almost whole amount of released CO₂, but rather trying to remove a much reduced amount, variable from 15 to 40%. It might be done with retrofit devices to be simply entailed to gas turbines, which should not undergo any internal modification in design and working conditions. Moreover, if solid (or

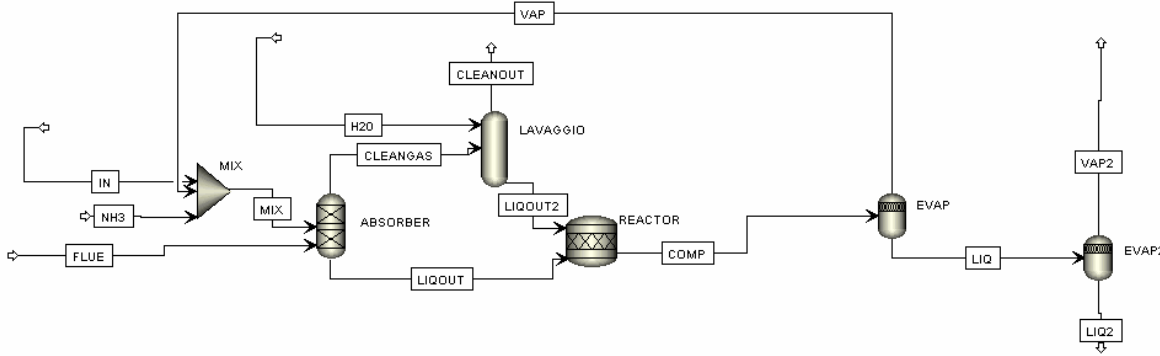

Figure 1 – Schematic of the CO₂ ammonia absorber plant

eventually liquid) valuable carbonate byproducts were produced (like fertilisers) it would add market value to the CO₂ removal. In the short term, it would help to meet the Kyoto goals because it should encourage the power industry to apply such system, especially in the EU where a carbon tax on the basis of CO₂ emissions for power production will be applied starting from 2006. In this way, even if a low amount of CO₂ was removed, a wide diffusion of retrofit systems should be promoted as far as their cost is reasonable and make the payback of the investment interesting when related to the savings in carbon tax.

As carbon dioxide is massively produced by all the fossil fuelled energy conversion systems, the choice of absorbent substance and the analysis of the released byproducts are fundamental topics and must be addressed in the direction of widely low cost available substances and extensively required products respectively. From this point of view, the possibility

of absorbing CO₂ by the use of ammonia and releasing agricultural valuable byproducts like ammonium bicarbonate and carbamate for urea production seems to be an interesting way of investigation [15].

Additionally, the possibility offered by the chemical absorption of CO₂ in solutions of phosphates has been assessed. Both ammonia and phosphates are widely available industrial products and their almost complete regeneration after the absorption might make the process environmentally and economically sustainable.

SCHEME AND MODELLING OF AMMONIA PLANT

The sketch of the CO₂ separation plant working with ammonia solution is shown on figure 1. The core of the process is the absorber, where the gas turbine's exhausts are put in contact with an ammonia – water solution stream. A partial CO₂ removal from fluegas is obtained, while a solution containing carbonate and ammonium ions is released. The following reactions are considered into the absorber for the CO₂ – NH₃ – H₂O solution:

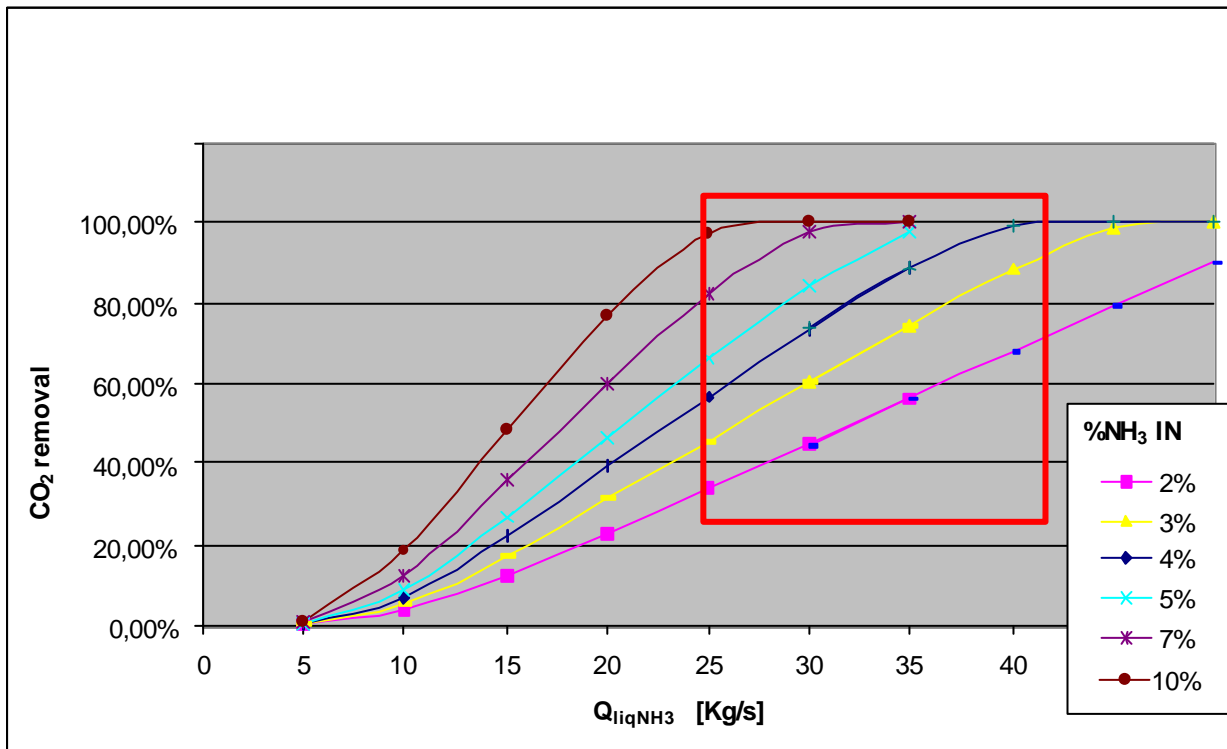

Figure 2 – Combined effect of ammonia solution mass flow and ammonia concentration on CO₂ removal from the gas turbine exhausts

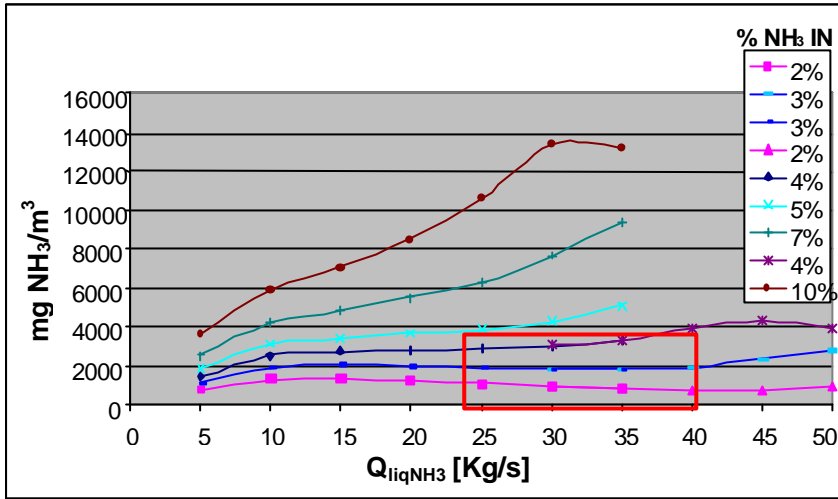
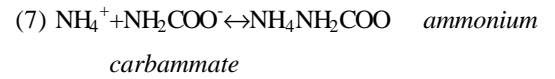
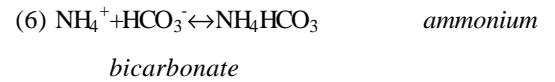

Figure 3 – NH₃ content of the absorber outgoing fluegas

- (1) $2\text{H}_2\text{O} \leftrightarrow \text{H}_3\text{O}^+ + \text{OH}^-$
- (2) $\text{CO}_2 + 2\text{H}_2\text{O} \leftrightarrow \text{H}_3\text{O}^+ + \text{HCO}_3^-$
- (3) $\text{HCO}_3^- + \text{H}_2\text{O} \leftrightarrow \text{H}_3\text{O}^+ + \text{CO}_3^{2-}$
- (4) $\text{NH}_3 + \text{HCO}_3^- \leftrightarrow \text{NH}_2\text{COO}^- + \text{H}_2\text{O}$
- (5) $\text{NH}_3 + \text{H}_2\text{O} \leftrightarrow \text{NH}_4^+ + \text{OH}^-$

Subsequently, the liquid solution coming out of the absorption tower is pressurised and sent to the reactor, where the solid carbonation reactions take place:



Downstream the reactor, a vaporizer enhances the concentration of ions and ammonium salts while separates the species with lower fusion temperature. The gaseous component going out of the vaporiser is thus recirculated at the plant inlet, by mixing with the water – ammonia solution.

The clean gas coming out of the absorption tower is, usually, too concentrated in NH₃, thus it is subsequently sent to a washing tower, in order to match the law limits in terms of NH₃ concentration (100 mg/m³). The gas is washed with clean water and the NH₃ (and partially CO₂) load solution is sent back to the reactor, in order

to improve the ammonium salts yield.

Finally, a second vaporiser is added to reduce the NH₃ concentration in the liquid solution coming out of the first vaporizer. The most of ammonia present in this liquid stream (LIQ) passes in vapour phase, whereas an extremely limited amount remains in the liquid solution leaving the second vaporiser (LIQ2), together with a fraction of water and the whole of ammonium salt, which is formed and not deposited, due to its very high water solubility.

The whole process and chemical reactions are modelled at equilibrium with ASPEN + code.

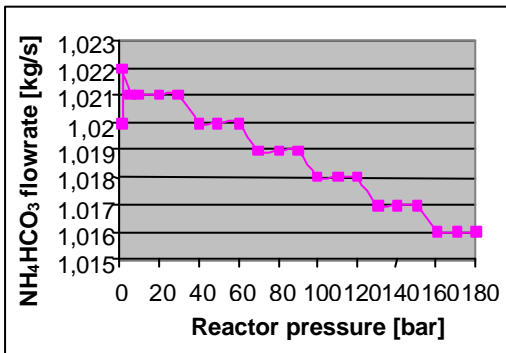

Figure 4 – Influence of reactor pressure on ammonium bicarbonate production

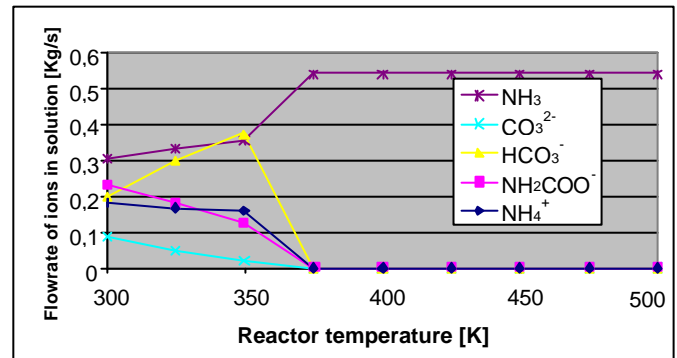

Figure 5 – influence of reactor temperature on the solution ions flowrate

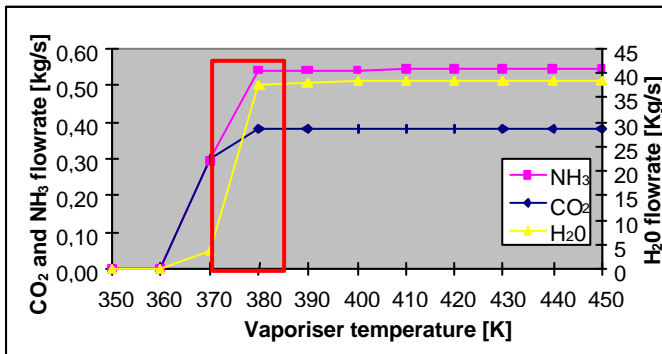

Figure 6 – Gaseous components flowrate at the vaporiser vs. vaporiser temperature

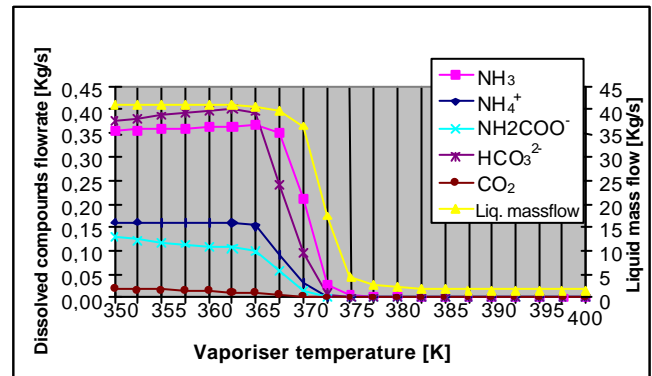

Figure 7 – Flowrate of liquid solution components at the vaporiser vs. vaporiser temperature

PARAMETRIC ANALYSIS OF THE MAIN COMPONENTS OF THE AMMONIA PLANT

As the main goal of the present work was the analysis of some possible ways for a not very high CO₂ removal from the gas turbine exhausts, containing typically low CO₂ concentrations, and the conversion of CO₂ to solid and/or liquid byproducts without modifying the power cycle and the related components, the deaning gas system must be applied as a retrofit to the powerplant. The mass composition of the exhausts sent to the carbon dioxide removal is the following:

H₂O = 4.9%; N₂ = 73.5%; CO₂ = 6.8%; O₂ = 14.7%, which is referred to a GE PGT10 and may be rather representative of general gas turbine cycles. The gas flowrate is 19.8 kg/s and its temperature is 850 K. It is subsequently cooled down to 175 °C, recovering the related heat content for sustaining the endothermic processes within the ammonia – CO₂ absorption system. The absorber is slightly pressurised at 1.5 bar and the inlet solution temperature is kept at the environmental value of 25 °C.

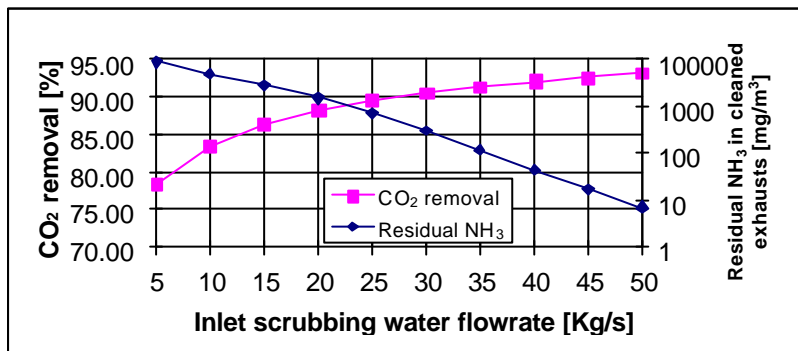

Figure 8– Residual ammonia and CO₂ removal in cleaned exhausts vs. scrubbing water flowrate

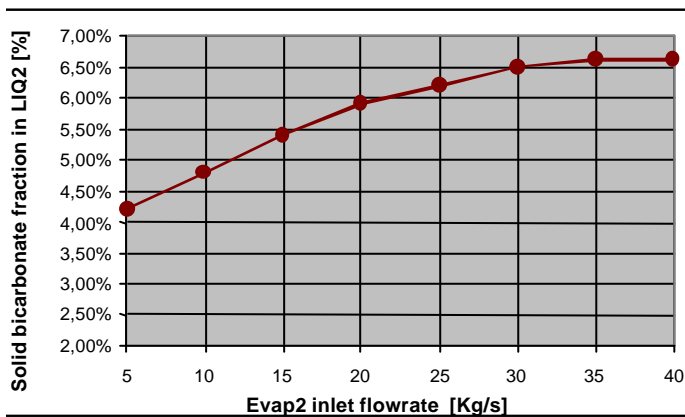

Figure 9– Fraction of solid carbonate vs. inlet flowrate at the second vaporiser

The main investigated working parameters of the absorption tower are the water ammonia solution flowrate, the ammonia concentration and the operating temperature.

As it is seen in figure 2, increasing solution mass flowrate and NH₃ concentration (%NH₃ IN), the CO₂ capture level is largely improved (the inlet solution also has a washing effect on the fluegas). The outgoing CO₂ cleaned fluegas has an ammonia content which exceeds the law limits (see figure 3), thus it has

to be further cleaned in the downstream washing tower. The amount of ammonia in the outgoing fluegas is largely sensitive to its concentration in the inlet solution, whereas it is almost constant with solution mass flow, except for high NH₃ concentrations.

The rectangle on the graphs of figures 2 and 3 defines a convenient working area in order to have an appreciable CO₂ removal (above 20%) and a rather limited NH₃ content in the outgoing fluegas. Thus, solution flowrates above 25 kg/s with NH₃ concentrations below 4% may be selected.

In the REACTOR, where the reactions (6) and (7) take place, the related formed salts have a very high solubility in water, thus they remain dissolved into the solution up to the saturation level. The sensitivity of NH₄HCO₃ production to the reactor pressure is very low, as shown on figure 4 (referred to an inlet temperature of liquid solution of 473 K and to a flowrate of 40 kg/s with NH₃ concentration of 3%).

The influence of reactor temperature on the content of ions dissolved in solution is shown on figure 5, for a fixed reactor pressure of 1 bar. It is seen that, above a certain critical temperature (depending on reactor pressure), only NH₃ and CO₂ species are present, due to the equilibrium of the reactions NH₄⁺ → NH₃ and HCO₃⁻ → CO₂, CO₃²⁻ → CO₂ which are rightward directed. The value of critical temperature decreases with increasing pressure, but the amount of formed ions is almost invariable with pressure. Generally, a slight improvement in salt production at low pressures is, however, achieved.

The compositions of gaseous and liquid phases at the vaporiser vs. temperature are reported on figures 6 and 7 respectively.

From figure 6, the area of interest (boxed) where the NH₃, CO₂ and H₂O species are maximised is between 370 and 380 K.

As previously remarked, the exhausts leaving the absorption tower contain an amount of NH₃ exceeding the law limits, at each value of ammonia concentration in the liquid solution. For this reason, the water scrubbing in the washing tower (LAVAGGIO in figure 1) is necessary. The behaviour of NH₃ and CO₂ removal as a function of inlet water flowrate is shown on figure 8, still referred to the same amount of absorbing solution (40 kg/s) and ammonia concentration (3%).

From this figure, it is clear that rather large amounts of scrubbing water (above 35 kg/s) are required in order to keep the released NH₃ below the law limits. On the other hand, an increase in scrubbing water flowrate improves the CO₂ removal level.

Concerning solid products, the ammonium salts which are formed in reactions are excessively soluble, thus their recovery is not simple, as they should be let deposit taking out the water still present within the solution by a further heating of the liquid leaving the second vaporiser. Unfortunately, this operation displaces the chemical equilibrium of salts toward the undesired CO₂ and NH₃ species, which are reformed. The fraction of solid product found in LIQ2 vs. inlet liquid flowrate in the second vaporiser is shown on figure 9. It is clear that only a limited amount of solid is produced, ranging from 4 to 7% of exhaust liquid and increasing with inlet flowrate.

CO₂ CAPTURE WITH AN AQUEOUS SOLUTION OF POTASSIUM PHOSPHATE

The second way here proposed for partial CO₂ capture from the diluted exhausts of gas turbines is the absorption with a solution of potassium phosphate (K₃PO₄). The gas composition and flowrate are the same adopted in the previous case of ammonia absorption. The following reactions are taken into consideration and modelled at equilibrium with ASPEN +:

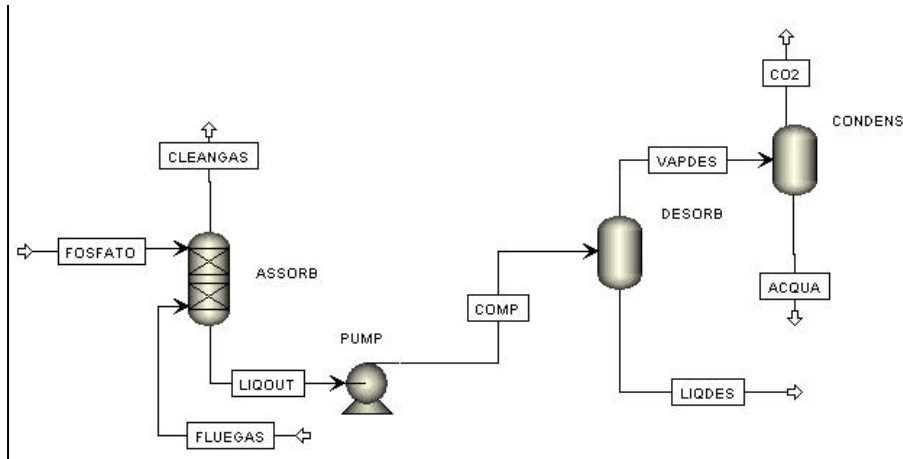
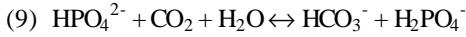
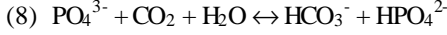

Figure 10 – schematic of phosphate absorption plant

desorber is condensed, in order to separate the water and release an almost pure stream of CO₂.

PARAMETRIC ANALYSIS OF THE PHOSPHATES SOLUTIONS BASED CO₂ ABSORPTION PLANT

The main parameters influencing the behaviour of the absorption tower are the inlet phosphates solution flowrate, the related phosphate concentration and temperature, and the temperature and pressure inside the tower. The objective is enhancing the capture of CO₂ and the production of carbonate ions. The exhausts entering the tower are cooled down from 850 to 350 K, whereas the solution of K₃PO₄ are assumed to be at the environmental temperature of 298 K (the reactions 8 and 9 are favoured at low temperatures).

The behaviour of carbon dioxide removal fraction vs. inlet solution flowrate, shown on figure 11 and related to a 4% concentrated solution, clearly evidences a linear increase of absorbed CO₂, which may exceed 80%.

The concentration of inlet solution is another important parameter which affects the behaviour CO₂ removal. The solubility limit of K₃PO₄ in water is around 0.90 g/cm³ of solution. The sensitivity of CO₂ removal fraction vs. solution concentration is shown on figure 12, for a fixed inlet solution flowrate of 20 kg/s.

An optimisation is clearly visible at 4,5% phosphate concentration, even though the

sensitivity to this parameter is much more limited when compared to that of solution flowrate.

The results at chemical equilibrium show a good potential of

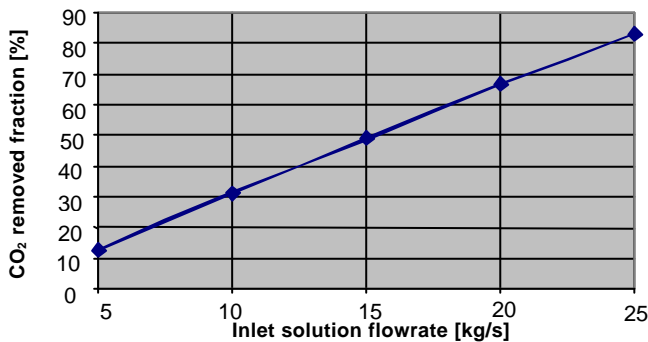

Figure 11 – CO₂ removal fraction vs. inlet solution flowrate

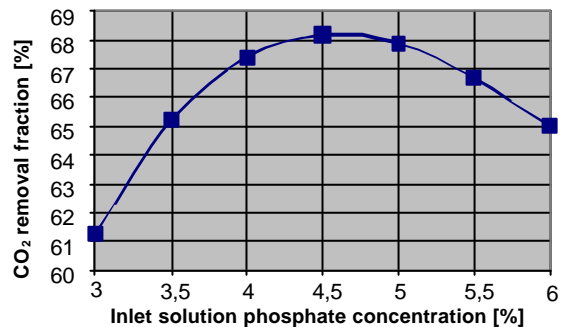

Figure 12 – CO₂ removal fraction vs. inlet solution phosphate concentration

The layout of phosphates absorption plant is shown on figure 10. The fluegas coming from the gas turbine is sent to the absorption tower (ASSORB), where the reactions (8) and (9) with the inlet phosphate solution take place. A fraction of CO₂ is removed, while a solution rich in phosphates and carbonates ions is released at the bottom of the tower. This solution is successively pumped to the desorber (DESORB), where the phosphate ions are recovered in order to have an almost complete regeneration of phosphates. This process is possible at high temperatures. Finally, the vapour fraction leaving the

CO₂ absorption when potassium phosphate solutions are used. Even at low inlet solution flowrates, 10 to 30% absorption potential is evidenced, which is an encouraging result when the removal plant is applied as a retrofit.

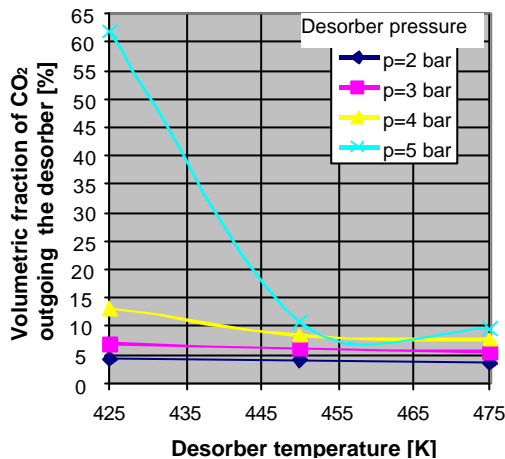

Figure 13 – volumetric fraction of CO₂ at desorber gaseous outlet vs. temperature and pressure

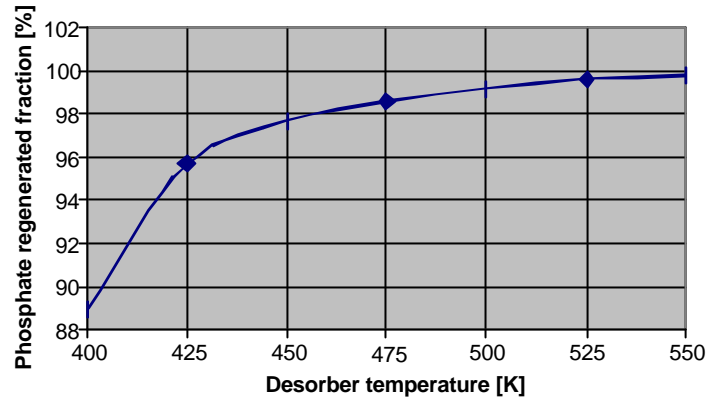

Figure 14 – fraction of regenerated phosphate vs. desorber temperature

DESORPTION AND CONDENSING SECTIONS

The main tasks of the desorber are the removal of the highest possible fraction of CO₂ in the liquid solution at the exit of the absorption tower and an almost complete regeneration of the phosphates solution. It is possible if the reactions (8) and (9) are leftward directed, which is favoured at high temperatures.

The volumetric fraction of CO₂ outgoing the desorber vs. temperature at different pressure levels are shown on figure 13 and indicate a little dependence on these two parameters, except for rather high pressures and low temperatures. However, in these cases, the flowrate of separated CO₂ is very low, due to the low leftward extension of reactions (8) and (9). Figure 14 shows the effect of temperature on the phosphate regeneration level. Increasing temperature, it is possible to reach an almost complete regeneration and even at the relatively low 425 K value the good 96% is achieved. The not complete recuperation of K₃PO₄ is due to the small fraction of HPO₄²⁻ ion, which remains in solution. Thus, a makeup flowrate is due.

The last device of the phosphates absorption plant is the condenser, where CO₂ is separated from the water vapour and an almost pure stream of CO₂ is released. Several calculations have shown that, if the desorber temperature is high enough to have a good phosphate regeneration together with an appreciable volumetric concentration of CO₂ in the gaseous stream, at the condenser outlet it is possible to achieve close to 99% concentration of carbon dioxide captured at the absorber. The level of this parameter is almost insensitive to the concentration and flowrate of the phosphate solution. Obviously, high cooling water flowrates are required at the condenser.

The ammonia and phosphates absorption systems may be coupled by sending the almost pure CO₂ stream leaving the condenser to the ammonia reactor, where the following reactions take place, with formation of solid ammonium carbamate and bicarbonate products:

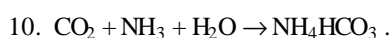
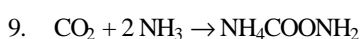

They are favoured at high pressure, whereas the temperature plays a marginal role. The production of ammonium carbamate is, potentially, much higher (around 97% against 3% bicarbonate). A little drawback of this process is due to the very small amount of ammonia which, in spite of its stoichiometric amount, remains unreacted and leaves the reactor as a gas. The whole of CO₂ is, however, transformed.

CONCLUSIONS

The possibility of applying ammonia and phosphates absorption of the diluted CO₂ exhausts from a gas turbine has been assessed here by the means of reaction equilibrium, modelled with ASPEN+ code. The ammonia absorption showed the interesting possibility of removing from 20 to almost 100% of CO₂ at the price of high inlet solution concentration and flowrate. The price is paid in terms of ammonia drawn with the exhausts: in order to respect the law limits, the NH₃ concentration into the inlet solution must not exceed the 4% level, which allows a CO₂ removal level between 25 and 90% with the use of reasonable solution mass flowrates. The salts formed in the section of “solidification” of removed carbon show a very high solubility in water, which generally remain dissolved into ions (only 4 – 7% solids are produced with respect to the entering ammonia solution).

The phosphates CO₂ absorption system has shown an interesting 10 to 90% potential of CO₂ absorption, mainly depending on the inlet solution mass flow. The concentration of phosphates solution has shown the possibility of optimising CO₂ separation level, but the influence of this parameter is more limited with respect to the solution flowrate. The regeneration of inlet phosphates is almost complete. Finally, the very interesting possibility of coupling phosphates and ammonia systems for (I) concentration of CO₂ and (II) production of solid ammonium carbamate and bicarbonate respectively came out.

REFERENCES

- [1] Adelman, S.T., Hoffman, M.A., Baughn, J.W., 1995, “A Methane-Steam Reformer for a Basic Chemically Recuperated Gas Turbine”, ASME Jnl of Engineering for Gas Turbines and Power, jan. 1995, Vol. 117, pp. 16-23.

- [2] Andersen, T., Kvamsdal, M., and Bolland, O., 2000, "Gas Turbine Combined Cycle with CO₂-capture using Auto-Thermal Reforming of natural gas", Proceedings of ASME Turbo Expo, , May 8-11, 2000, Munich, Germany.
- [3] Chiesa, P., Consonni, S., 1999, "Shift Reactors and Physical Absorption for Low-CO₂ Emission IGCCs", ASME Journal of Engineering for Gas Turbines and Power, Vol. 121, pp. 295-305.
- [4] Lozza, G., Chiesa, P., a), "NATURAL GAS DECARBONIZATION TO REDUCE CO₂ EMISSION FROM COMBINED CYCLES. PART A: PARTIAL OXIDATION", Paper 2000-GT-0163, ASME IGTI Conference & Exhibition, Munich 2000.
- [5] Lozza, G., Chiesa, P., b), "NATURAL GAS DECARBONIZATION TO REDUCE CO₂ EMISSION FROM COMBINED CYCLES. PART B: STEAM-METHANE REFORMING", Paper 2000-GT-0164, ASME IGTI Conference & Exhibition, Munich 2000.
- [6] Fiaschi, D., Lombardi, L. and Tapinassi, L., *The Recuperative Auto Thermal Reforming and Recuperative Reforming Gas Turbine Power Cycles With CO₂ Removal—Part I: The Recuperative-Auto Thermal Reforming Cycle*, Journal of Engineering for Gas Turbines and Power, Vol. 125, No. 4, pp. 933–939, October 2003
- [7] Fiaschi, D., Lombardi, L. and Tapinassi, L., *The Recuperative Auto Thermal Reforming and Recuperative Reforming Gas Turbine Power Cycles With CO₂ Removal—Part II: The Recuperative Reforming Cycle*, Journal of Engineering for Gas Turbines and Power, Vol. 126, No. 1, pp. 62–68, January 2004
- [8] Corti, A., Failli, L., Fiaschi, D., and Manfrida, G., 1998, "Exergy Analysis of Two Second-Generation SCGT Plant Proposals," Proceedings of ASME IGTI 43rd Gas Turbine and Aeroengine Congress and Exhibition, Stockholm, Sweden.
- [9] Facchini, B., Fiaschi, D., and Manfrida, G., 1997, "SCGT/CC: An Innovative Cycle With Advanced Environmental and Peakload Shaving Features," Energy Convers. Manage., **38** (15–17), pp. 1647–1653 (ScienceDirect)
- [10] Mathieu, Ph., Dechamps, P., and Distelmans, M., 1994, "Concepts and Applications of CO₂ Gas Turbines," Power-Gen Europe '94, Cologne
- [11] Corti, A., Lombardi, L., Manfrida, G., b) "Absorption of CO₂ with amines in a semi-closed GT cycle: Plant Performance and Operating Costs" Proceedings of ASME IGTI 43rd Gas Turbine and Aeroengine Congress and Exhibition, Stockholm, Sweden, June, 1998.
- [12] Corti, A., Manfrida, G., c) "Economic Analysis of a Semi-Closed Gas Turbine/Combined Cycle (SCGT/CC) with CO₂ removal by amines absorption", GHGT-4, "4th International Conference on Greenhouse Gas Control Technologies", InterLaken, Switzerland, August 30 - September 2 1998.
- [13] Corti, A., Fiaschi, D., Manfrida, G., "Thermo-Economic Evaluation of the SCGT Cycle", Energy Conversion & Management Vol. 40 (1999), pp.1917-1929.
- [14] IEA, 2000, "Carbon Dioxide Capture and Storage", report from Dept. of Trade and Industry, September 2000, on www.dti.gov.uk/cct.
- [15] James Weifu Lee and Rongfu Li, *Integration of fossil energy systems with CO₂ sequestration through NH₄HCO₃ production*, Energy Conversion and Management, Volume 44, Issue 9, June 2003, Pages 1535-1546