



UNIVERSITÀ
DEGLI STUDI
FIRENZE

FLORE

Repository istituzionale dell'Università degli Studi di Firenze

Atom interferometers and optical atomic clocks: New quantum sensors for fundamental physics experiments in space

Questa è la Versione finale referata (Post print/Accepted manuscript) della seguente pubblicazione:

Original Citation:

Atom interferometers and optical atomic clocks: New quantum sensors for fundamental physics experiments in space / G.M. TINO; L.CACCIAPUOTI; K.BONGS; C.J.BORDE; P.BOUYER; H.DITTUS; W.ERTMER; A.GORLITZ; M.INGUSCIO; A.LANDRAGIN; P.LEMONDE; C.LAMMERZAHN; A.PETERS; E.RASEL; J.REICHEL; C.SALOMON; S.SCHILLER; W.SCHLEICH; K.SENGSTOCK; U.STERR; M.WILKENS. - In: NUCLEAR PHYSICS B-PROCEEDINGS SUPPLEMENTS. - ISSN 0920-5632. - STAMPA. - 166:(2007), pp. 159-165.

Availability:

This version is available at: 2158/256795 since:

Terms of use:

Open Access

La pubblicazione è resa disponibile sotto le norme e i termini della licenza di deposito, secondo quanto stabilito dalla Policy per l'accesso aperto dell'Università degli Studi di Firenze (<https://www.sba.unifi.it/upload/policy-oa-2016-1.pdf>)

Publisher copyright claim:

(Article begins on next page)



ELSEVIER

Available online at www.sciencedirect.com

 ScienceDirect

Nuclear Physics B (Proc. Suppl.) 166 (2007) 159–165

NUCLEAR PHYSICS B
PROCEEDINGS
SUPPLEMENTS

www.elsevierphysics.com

Atom interferometers and optical atomic clocks: New quantum sensors for fundamental physics experiments in space

G. M. Tino^{a*}, L. Cacciapuoti^b, K. Bongs^c, Ch. J. Bordé^d, P. Bouyer^e, H. Dittus^f, W. Ertmer^g, A. Görlitz^h, M. Inguscio^a, A. Landraginⁱ, P. Lemondeⁱ, C. Lammerzahl^f, A. Peters^j, E. Rasel^g, J. Reichel^k, C. Salomon^k, S. Schiller^h, W. Schleich^l, K. Sengstock^c, U. Sterr^m, M. Wilkensⁿ

^aDipartimento di Fisica and LENS, Università di Firenze, INFN, via Sansone 1, Sesto Fiorentino, I

^bESA, Research and Scientific Support Department, ESTEC, 2200 AG Noordwijk, NL

^cInstitut fuer Laser-Physik, Universitaet Hamburg, Luruper Chaussee 149, 22761 Hamburg, D

^dLPL, UMR 7538 CNRS, Université Paris Nord, Villetaneuse, F

^eLaboratoire CF de l'Institut d'Optique, CNRS et Université Paris Sud 11, Orsay, F

^fZARM, University of Bremen, Bremen, D

^gInstitut für Quantenoptik, Leibniz Universität Hannover, Welfengarten 1, 30167 Hannover, D

^hInstitut für Experimentalphysik, Universität Düsseldorf, Düsseldorf, D

ⁱLNE-SYRTE, Observatoire de Paris and CNRS, Paris, F

^jInstitut für Physik, Humboldt–Universität zu Berlin, Berlin, D

^kLaboratoire Kastler Brossel, ENS - Département de Physique, Paris, F

^lUniversität Ulm, Ulm, D

^mPhysikalisch-Technische Bundesanstalt, Bundesallee 100, 38116 Braunschweig, D

ⁿUniversität Potsdam, Potsdam, D

We present projects for future space missions using new quantum devices based on ultracold atoms. They will enable fundamental physics experiments testing quantum physics, physics beyond the standard model of fundamental particles and interactions, special relativity, gravitation and general relativity.

1. Introduction

Atomic quantum sensors based on cold atom physics have already demonstrated their potential for precision measurements. Today, atomic clocks approach a precision of few parts in 10^{17} in the measurement of time and frequency; on ground, atom interferometers promise sensitivities of $10^{-10} \text{g}/\sqrt{\text{Hz}}$ for acceleration measure-

ments and of $10^{-9} \text{rad}/s\sqrt{\text{Hz}}$ for the detection of tiny rotations; the study of bosonic and fermionic quantum degenerate gases is important not only for basic research, but also for potential improvements of the performances of atomic quantum sensors.

Space is a unique environment for improving the performances of these new devices and pushing to the limits the experiments testing the fundamental laws of physics. Space can ensure in-

*E-mail: guglielmo.tino@fi.infn.it

finitely long and unperturbed "free fall" conditions, long interaction times, quiet environmental conditions and absence of seismic noise, absence of atmosphere, large free-propagation distances and variations in altitude, large velocities, large variations of the gravitational potential.

The field of laser cooling and manipulation of atoms has been one of the most active in physics in recent years. Atoms from a room-temperature vapour can be cooled to temperatures as low as a few nanokelvin. At such low temperatures, the wave properties of the atoms become relevant and this gives rise to completely new phenomena such as Bose-Einstein condensation and allows to perform experiment where the matter waves interfere just as usual waves do. In 1997, the Nobel Prize in physics was awarded to C. Cohen-Tannoudji, S. Chu and W.D. Phillips for their contribution in this field [1]. In 2001, the Nobel Prize was given to E.A. Cornell, W. Ketterle and C.E. Wieman for the observation of Bose-Einstein condensation in ultracold dilute atomic gases [2]. In 2005, J.L. Hall and T.W. Hänsch received the Nobel Prize for the invention of a method that will lead to new clocks based on optical transitions of ultracold atoms [3].

The field is now mature both from the point of view of the understanding of the basic physics underlying laser cooling and laser manipulation of atoms and for the development of a solid technology for the experimental implementation of new quantum devices.

In the frame of ELIPS 2 ("European Life and Physical Science") Programme, the European Space Agency (ESA) is launching new projects to demonstrate the technology readiness of the proposed systems, followed by the development of ground-based prototypes and transportable instruments which will be used as benchmarks for the design of space qualified hardware.

These pioneering activities will lead to new technologies with wide applicability covering diverse and important topics ranging from fundamental physics tests to applications to very long baseline interferometry, realization of SI-units and metrology, global time-keeping, deep-space navigation, secure communication, prospecting for resources, GALILEO technol-

ogy, geodesy, gravimetry, environment monitoring, major Earth-science themes, LISA technology development, planetary exploration.

In this paper, projects are discussed that rely on cold atoms devices to investigate fundamental physics laws in future space missions. These experiments will lead to new tests of quantum physics, physics beyond the standard model of fundamental particles and interactions, special relativity, gravitation and general relativity.

2. Optical atomic clocks in space

Although present microwave atomic clocks reached remarkable performances, a new type of clocks based on optical atomic transitions promises dramatic improvements. In an optical atomic clock, a laser in the visible region of the electromagnetic spectrum is used to induce a forbidden atomic transition. The resonance signal is detected by measuring the population in the two clock levels and used to keep the laser frequency tuned on the atomic transition (Fig. 1). By using optical frequencies ($\nu_0 \sim 10^{15}$ Hz) rather than microwave frequencies ($\nu_0 \sim 10^{10}$ Hz), an optical clock operates with a much smaller unit of time. This leads to an enormous improvement in stability and also to a higher accuracy since several key frequency shifts are fractionally much smaller in the optical domain [4].

The measurement of optical frequencies has recently been made practical by the development of the femtosecond-laser frequency-combs [5,6]. Combined with narrow linewidth lasers, this has made possible the first generation of optical atomic frequency standards and clocks, based on cold trapped neutral atoms, such as Sr or Yb, and ions, such as Sr^+ , Yb^+ , Al^+ , Hg^+ . Optical clocks have already demonstrated stabilities below 1 part in 10^{14} at 1 s integration time and 5 parts in 10^{17} at 20 000 s and have the potential to reach a systematic fractional frequency uncertainty approaching 10^{-18} level [7,8].

In space, where the weightlessness and the extremely quiet environment ensure the ideal conditions for detecting very narrow signals, these performances can be improved even further. Clocks in space represent unique tools to test funda-

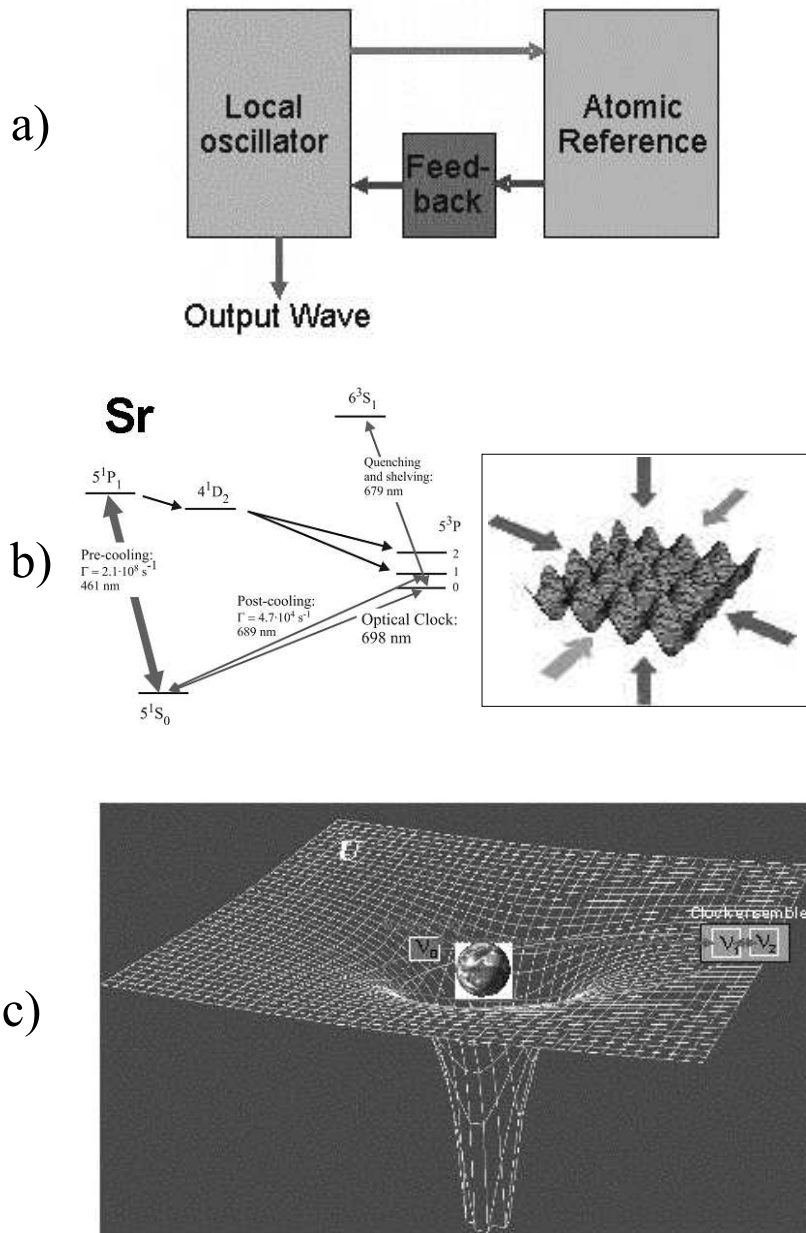

Figure 1. a) The principle of an atomic clock. b) Scheme for an atomic clock based on a forbidden optical transition of ultracold Sr atoms. Neutral atoms are trapped in an optical lattice. c) Artist's view of the mission based on atomic clocks orbiting around the Earth.

mental laws of physics at an unprecedented level of accuracy and to develop applications in time and frequency metrology, universal time scales, global positioning and navigation, geodesy, and gravimetry.

Measurements of the constancy and isotropy of the speed of light can be performed by continuously comparing a space clock to a ground clock. Tests based on this technique have already been performed in 1997 by comparing clocks on-board GPS satellites to a hydrogen maser [9]. Optical clocks orbiting around the Earth, combined to a time and frequency transfer link not degrading the clock performances can improve present results by about four orders of magnitude. Optical clocks could measure the Einstein's gravitational red-shift with a relative uncertainty of few parts in 10^8 , demonstrating a new efficient way of mapping the Earth gravity field and define the shape of the geoid at the cm level. At the same time, the comparison of two optical clocks based on appropriately chosen transitions during free flight in a varying gravitational potential can test the universality of the gravitational red-shift at the same accuracy level. As direct consequence of Einstein's equivalence principle, general relativity and other metric theories of gravitation forbid any time variation of non-gravitational constants. Today, optical clocks offer the possibility to test time variations of fundamental constants at a high accuracy level [10,11]. Such measurements complement the tests of the local Lorentz invariance and of the universality of the free fall to experimentally establish the validity of Einstein's equivalence principle.

Third generation navigation systems will benefit from the technology development related to optical clocks. New concepts for global positioning systems based on a reduced set of ultra-stable space clocks in orbit associated with simple transponding satellites could be studied and, as already discussed, a new kind of geodesy based on the precise measurement of the gravitational red-shift can be envisaged.

At present, the most advanced project on microwave atomic clocks based on cold atoms for space is ACES (*Atomic Clock Ensemble in Space*). Details on the ACES mission and its status can

be found in Ref. [12] and in the paper by L. Cacciapuoti et al. in this issue.

The ESA project *Space Optical Clocks* [13] will demonstrate the high potential of the emerging technology of optical clocks both for fundamental physics studies and applications. Optical clock laboratory demonstrators based on Strontium and Ytterbium atoms will be realized, characterized, and compared preparing the background for the development of optical clocks for space applications.

3. Atom interferometry sensors for space applications

Recent advances in atom interferometry led to the development of new methods for fundamental physics experiments and for applications [14]. In particular, atom interferometers are new tools for experimental gravitation as, for example, for precision measurement of gravity acceleration [15], gravity gradients [16], Newtonian gravitational constant G [17], gravity at micrometric distances [18,19], and for testing equivalence principle [20]. The possibility of detecting gravitational waves by atom interferometry was also discussed [21,22].

Future experiments in space will allow to take full advantage of the potential sensitivity of cold atom interferometers as acceleration or rotation sensors [23] (Fig. 2). A feasibility study (HYPER) was already performed by ESA for an atom gyroscope orbiting around the Earth to map the Lense-Thirring effect [24].

Indeed, cold-atom optics and interferometry developed during the last decade from proof-of-principle experiments to quantum sensors of highest sensitivity. Inertial and rotational sensors using atom interferometers display a potential for replacing other state-of-the-art sensors.

Atom interferometers represent therefore a new important technology with future applications e.g. for fundamental physics, navigation, metrology, and geology. In all these fields the intrinsic benefits making direct use of fundamental quantum processes promises significant advances in performance, usability, and efficiency, from the deployment of highly optimized devices on satellites in space or from the use of ground

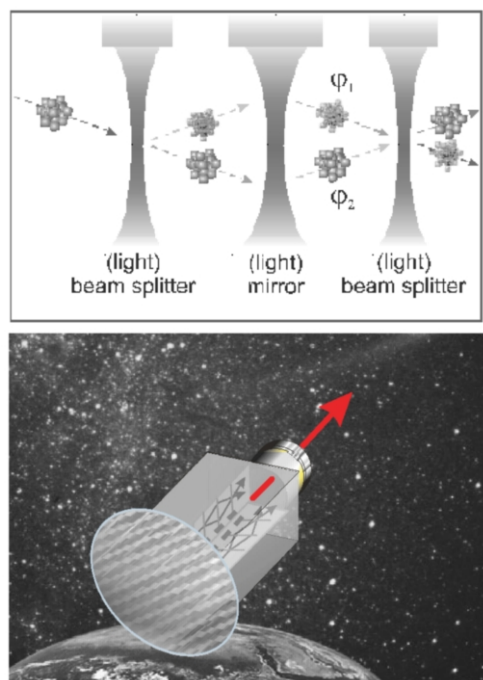

Figure 2. a) Basic scheme of an atom interferometer. The atomic beam is split and recombined using atom optics elements. By detecting the atoms at the output ports, an interference signal is obtained. b) Scheme of an atom interferometer system in a satellite orbiting around the Earth.

based transportable devices. The strong motivation for operation in space is that the ultimate performance of atomic quantum sensors will be boosted by orders of magnitude under conditions of weightlessness.

The applications of atomic quantum sensors are truly interdisciplinary, covering diverse and important topics. In fundamental physics space-based cold atom sensors may be the key for ground breaking experiments on fundamental tests (general relativity and string theories), test of $1/r^2$ law for gravitational force at micrometric distances, neutrality of atoms, or in the quest for a universal theory reconciling quantum theory and gravity. Possible applications can be envis-

aged in astronomy and space navigation (inertial and angular references), realization of SI-units (definition of kg, measurements of Newtonian gravitational constant G , h/m measurement), GALILEO and LISA technology, prospecting for resources and major earth-science themes.

The ESA project *Atom Interferometry Sensors for Space Applications* [25] aims to push present performances to the limits and to demonstrate this technology with a transportable sensor which will serve as a prototype for the space qualification of the final instrument.

4. Quantum gases in microgravity

A gas of identical particles, cooled down to very low temperatures and constrained in trapping potentials where high densities can be reached, undergoes a phase transition from a classical to a macroscopic quantum system. Identical particles start occupying the lowest energetic states of the confining potential behaving as a quantum many-body system with well defined properties depending on the bosonic or fermionic nature of the particles themselves.

The ground state of a bosonic gas is macroscopically populated when the de Broglie wavelength λ_{dB} of the particles becomes comparable to the interparticle separation. This condition, also called quantum degeneracy, occurs when $\rho = n \cdot \lambda_{dB}^3 \simeq 2.61$, where n is the density of the sample and ρ is the so called phase-space density.

After the first experimental realization of Bose-Einstein condensation (BEC) [26,27], many studies have extensively investigated the properties of this new state of matter, including the thermodynamics of the phase transition, the collective oscillation modes of the sample, its coherence properties and superfluid behaviour, BEC physics in extremely confined potentials (1D or 2D geometries) or in optical lattices. Furthermore, the realization of BEC is paving the way for future and more elaborate studies of quantum many-body systems, including degenerate Fermi gases and Bose-Fermi mixtures. At present, laboratory experiments can routinely produce BECs with typical temperatures down to few tens of

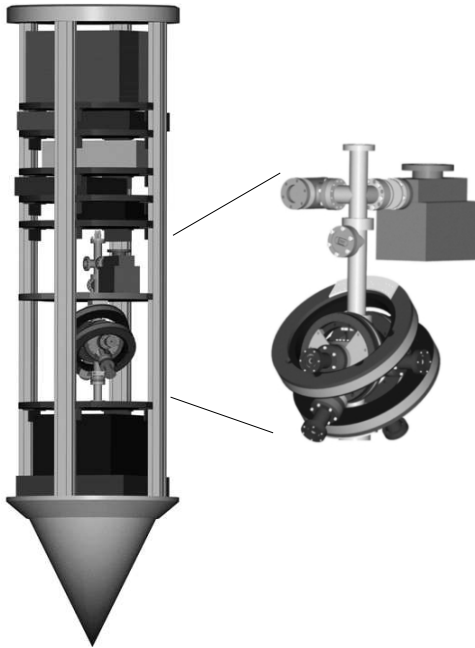

Figure 3. Scheme of the apparatus developed in the QUANTUS project to investigate BEC in microgravity at the ZARM drop tower in Bremen [28]. The dropcapsule with a payload size of 173 cm height and 81 cm diameter contains the vacuum chamber, power supply, computer control, RF electronics, laser electronics and all the optical components needed for the experiment.

nK. Nevertheless, even at these ultra-low temperatures, residual kinetic energy plays a significant role, masking important effects related to the quantum nature of the system. In microgravity the thermal motion of atoms can be reduced even further, and temperatures in the low pK or even fK regime are accessible. Furthermore, very long expansion times can be achieved in an almost perturbation-free environment, where the atomic sample can evolve unbiased by gravity and without any need for levitation.

These conditions set the stage for innovative studies on the physics of degenerate quantum

gases in microgravity (Fig. 3) and for the utilization of coherent sources of ultra-cold atoms to enhance the performances of atom interferometry sensors in space [29].

5. Conclusions

Recent scientific and technological advances have produced new quantum devices based on ultracold atoms that with their performances are challenging our understanding of the universe and of the physical laws of nature.

In this paper, ongoing activities and projects for future fundamental physics experiments in space were presented.

The development of projects on cold-atom based systems will bring about outstanding scientific results and mature space-proved technology within a plausible time frame of 5 to 10 years.

Programs in fundamental physics will be a unique opportunity to consolidate this new technology and prepare key instruments for future space missions.

Acknowledgments

The authors thank the members of the scientific teams involved in the projects. Support by ESA and national space agencies is acknowledged.

REFERENCES

1. S. Chu, C. Cohen-Tannoudji, W. D. Phillips *Nobel Lectures in Physics 1997*, Rev. Mod. Phys. **70**, 685 (1998).
2. E. A. Cornell and C. E. Wieman, *Nobel Lectures in Physics 2001*, Rev. Mod. Phys. **74**, 875, 1131 (2002); W. Ketterle, *ibid.*, 1131 (2002).
3. J.L. Hall and T.W. Hänsch, *Nobel Lectures in Physics 2005*, Rev. Mod. Phys., in press.
4. P. Gill, *Metrologia* **42**, S125 (2005).
5. Th. Udem *et al.*, Phys. Rev. Lett. **82**, 3568 (1999).
6. S. A. Diddams *et al.*, Phys. Rev. Lett. **84**, 5102 (2000).
7. T. Rosenband *et al.*, in *Proc. 20th European Frequency and Time Forum*, 27-30 March 2006, Braunschweig, Germany, in press.

8. W. H. Oskay *et al.*, Phys. Rev. Lett. **97**, 020801 (2006).
9. P. Wolf and G. Petit, Phys. Rev. A **56**, 4405 (1997).
10. H. Marion *et al.*, Phys. Rev. Lett. **90**, 150801 (2003).
11. S. Bize *et al.*, Phys. Rev. Lett. **90**, 150802 (2003).
12. L. Cacciapuoti *et al.*, in *Proc. 1st ESA International Workshop on Optical Clocks*, 8-10 June 2005, Noordwijk, NL, ESA Publication, p. 45 (2005).
13. S. Schiller *et al.*, *Space Optical Clocks*, proposal submitted to *ESA Announcement of Opportunity 2004*.
14. P.R. Berman, ed., *Atom interferometry* (Academic press, 1997)
15. A. Peters, K.Y. Chung, S. Chu, Nature **400**, 849 (1999)
16. M.J. Snadden, J.M. McGuirk, P. Bouyer, K.G. Haritos, M.A. Kasevich, Phys. Rev. Lett. **81**, 971 (1998)
17. A. Bertoldi *et al.*, Eur. Phys. J. D, in press; arXiv:physics/0606126
18. S. Dimopoulos, A.A. Geraci, Phys. Rev. D **68**, 124021 (2003)
19. G. Ferrari, N. Poli, F. Sorrentino, G.M. Tino, Phys. Rev. Lett. **97**, 060402 (2006)
20. S. Fray, C.A. Diez, T.W. Hänsch, M. Weitz, Phys. Rev. Lett. **93**, 240404 (2004)
21. C. Bordé, G.M. Tino, F. Vetrano, *2004 Aspen Winter College on Gravitational Waves* (Available online at: www.ligo.caltech.edu/LIGO_web/Aspen2004 (to be published)
22. A. Roura, D.R. Brill, B.L. Hu, C.W. Misner, W.D. Phillips, Phys. Rev. D **73**, 084018/1 (2006)
23. F. Yver-Leduc, *et al.*, J. Opt. B: Quantum Semiclass. Opt. **5**, S136 (2003)
24. *HYPHER, Hyper Precision Cold Atom Interferometry in Space, ESA Assessment study report, ESA-SCI (2000) 10*. Available online at <http://sci.esa.int/>
25. G. M. Tino *et al.*, *Atom Interferometry Sensors for Space Applications*, proposal submitted to *ESA Announcement of Opportunity 2004*.
26. M.H. Anderson *et al.*, Science **269**, 198 (1995).
27. K.B. Davis *et al.*, Phys. Rev. Lett. **74**, 3969 (1995).
28. A. Vogel *et al.*, Appl. Phys. B (2006), in press.
29. W. Ertmer *et al.*, *Quantum Gases/Bose-Einstein Condensates in Microgravity*, proposal submitted to *ESA Announcement of Opportunity 2004*.