



UNIVERSITÀ  
DEGLI STUDI  
FIRENZE

## FLORE

# Repository istituzionale dell'Università degli Studi di Firenze

### **A new approach to FET model scaling and MMIC design based on electromagnetic analysis**

Questa è la Versione finale referata (Post print/Accepted manuscript) della seguente pubblicazione:

*Original Citation:*

A new approach to FET model scaling and MMIC design based on electromagnetic analysis / A.CIDRONALI; G.COLLODI; G.VANNINI; A.SANTARELLI; G. MANES. - In: IEEE TRANSACTIONS ON MICROWAVE THEORY AND TECHNIQUES. - ISSN 0018-9480. - STAMPA. - 47:(1999), pp. 900-907. [10.1109/22.769324]

*Availability:*

This version is available at: 2158/310062 since: 2017-04-24T09:17:14Z

*Published version:*

DOI: 10.1109/22.769324

*Terms of use:*

Open Access

La pubblicazione è resa disponibile sotto le norme e i termini della licenza di deposito, secondo quanto stabilito dalla Policy per l'accesso aperto dell'Università degli Studi di Firenze (<https://www.sba.unifi.it/upload/policy-oa-2016-1.pdf>)

*Publisher copyright claim:*

(Article begins on next page)

# A New Approach to FET Model Scaling and MMIC Design Based on Electromagnetic Analysis

Alessandro Cidronali, *Member, IEEE*, Giovanni Collodi, Giorgio Vannini, *Member, IEEE*, Alberto Santarelli, *Member, IEEE*, and Gianfranco Manes

**Abstract**—A new approach, using electromagnetic analysis, is proposed for field-effect transistor model scaling and monolithic-microwave integrated-circuit (MMIC) design. It is based on an empirical distributed modeling technique where the active device is described in terms of an external passive structure connected to a suitable number of internal active sections. On this basis, an equivalent admittance matrix per gate unit width is obtained which, as confirmed by experimental results provided in this paper, is consistent with simple scaling rules. The same technique can also be adopted for a “global approach” to MMIC design where complex electromagnetic phenomena are also taken into account. An example of application concerning this aspect is presented.

**Index Terms**—Microwave FET’s, millimeter-wave FET’s, MIMIC’s, MMIC’s, semiconductor device modeling.

## I. INTRODUCTION

THE development of high-performance microwave and monolithic microwave integrated circuits (MMIC’s) requires global design procedures [1]–[3] where not only the values of passive (lumped or distributed) components, but also the active device geometry (e.g., number of fingers and gatewidth) represent available design parameters. Moreover, demanding low-cost requirements lead to a higher level of integration with possible complex coupling effects, which may strongly affect circuit performance.

In this context, the availability of robust scaling procedures for FET models is a key aspect. These should be capable of providing the electrical characteristics of an electron device as functions of, at least, its size and finger number or, hopefully and more generally, its geometry.

Conventional scalable models, provided together with the design rules of most GaAs foundries, are usually based on equivalent circuits whose parameters are scaled with device size and finger number according to different approaches<sup>1, 2, 3</sup>

Manuscript received October 26, 1998. This work was supported in part by the Italian National Research Council and by the Ministry of the University and Scientific and Technological Research.

A. Cidronali, G. Collodi, and G. Manes are with the Department of Electrical Engineering, University of Florence, 50139 Florence, Italy.

G. Vannini is with the Department of Engineering, University of Ferrara, 44100 Ferrara, Italy.

A. Santarelli is with CSITE, Italian National Research Council, 40136 Bologna, Italy.

Publisher Item Identifier S 0018-9480(99)04456-7.

<sup>1</sup>HP-EE’s of Series IV, Circuit Element Catalog, 1996.

<sup>2</sup>Philips Microwave, “Foundry process ED02AH V 1.1 design manual,” 1997.

<sup>3</sup>GEC-Marconi, “Foundry process F20 design manual,” 1996.

[4]; these range from very simple linear rules to completely empirical expressions (defined on the only basis of a good fitting with the electrical responses measured for a number of different device structures). At relatively high operating frequencies, some of these approaches may not be sufficiently accurate, and a relevant effort may be required to obtain a good scalable model. More precisely, a large number of measurements on different device structures is needed, besides a particular attention to parasitic modeling and identification. One of the main problems is related to the limited accuracy of the lumped description of intrinsically distributed phenomena [5], such as propagation along the metallizations, terminal coupling, etc.

A possible alternative to conventional equivalent circuits is based on the use of distributed models [6]–[12], which usually consist of a cascade of elementary devices, representing the active area of the electron device, fed by lumped passive networks which should model signal propagation and other electromagnetic phenomena related to the passive structure. These models, however, have not been extensively used in practice (probably due to the complexity of the identification procedures).

Recently, the progress in numerical device simulation and the development of electromagnetic analysis tools, together with the availability of powerful workstations, have led to modeling approaches aimed to the numerical solution of the electromagnetic and electron transport problems in a consistent way [13]–[17]. Although potentially accurate, these models are still in a preliminary phase and their application to practical problems such as device scaling, circuit simulation, etc., may be difficult, also taking into account their computational cost.

In this paper, a new approach to field-effect transistor (FET) model scaling for MMIC design is proposed, which is based on an empirical distributed model [18], [19] composed of an “extrinsic passive structure” connecting a convenient number of elementary “active slices.” In particular, the extrinsic part of the electron device is characterized in terms of scattering parameters, by means of accurate electromagnetic simulations [18]–[25]. This kind of analysis enables the actual device geometry and material stratification, as well as losses in the dielectrics and metallizations, to be taken into account, for any given device structure and size, by means of a multiport  $S$ -matrix “distributed” description. Finally, on the basis of  $S$ -parameters measured for a limited number of devices, a characterization of the “intrinsic slices,” mainly

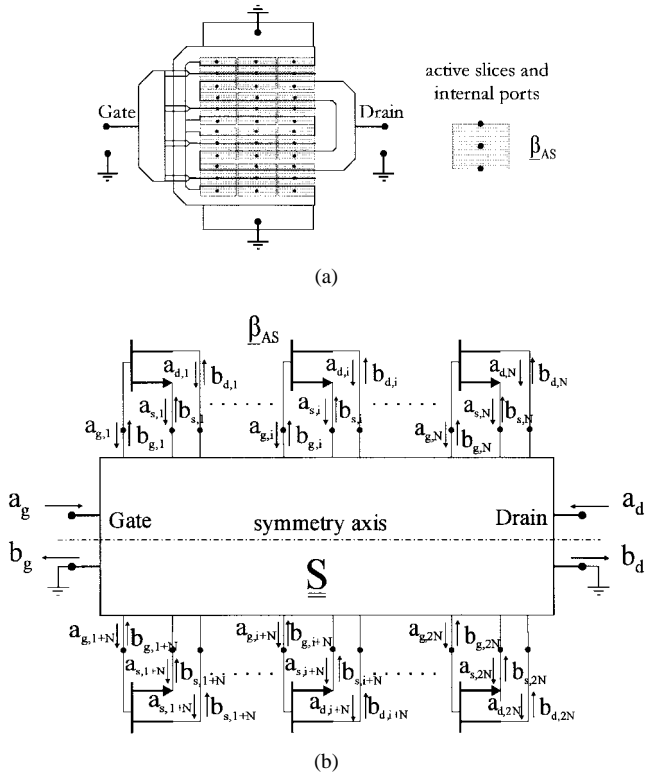

Fig. 1. FET partitioning. (a) Layout of a four-finger FET with active slices and internal ports. (b) Equivalent representation.

associated with the active phenomena, is obtained, which is consistent with simple scaling rules. One of the main and more interesting features is that this “intrinsic description” can easily be adopted in a “global design approach,” based on electromagnetic simulation, to account for complex coupling effects in circuit layouts or to predict the electrical performance of nonconventional device structures that could be exploited to design highly integrated low-cost MMIC’s.

The empirical distributed model and associated identification procedures are described in Section II, while a discussion on the scaling rules for the active slices and experimental results for GaAs metal–semiconductor FET’s (MESFET’s) are provided in Sections III and IV, respectively. Finally, in Section V, a discussion on the main features of the proposed approach and an example of application for the performance prediction of high-density device structures are presented.

## II. THE EMPIRICAL DISTRIBUTED MODEL

The electron device is assumed to consist of an “extrinsic passive network” connected with a finite number of elementary “active slices,” as shown in Fig. 1(b). This description is intuitively suggested by the structure layout of a conventional FET, shown in Fig. 1(a). More precisely, the active part of the electron device is partitioned along each gate finger in a suitable number of active sections [the shaded areas in Fig. 1(a)], which are interconnected by means of internal ports to the extrinsic passive network.

The number of active sections that must be considered strongly depends on the device geometry and operating fre-

quency range. Many authors adopt the approximate dimension  $\lambda_g/10$  ( $\lambda_g$  being the electrical wavelength) as the limit above which distributed effects must be accounted for and as a thumb rule to introduce the proper number of active slices along the gate metallization. More realistically, this number also depends on model accuracy versus complexity considerations. Moreover, a further insight shows that the distributed nature of the signal division between gate fingers is generally not negligible [25]. Therefore, each gate finger is specifically accounted for in the structure of the proposed model.

As far as model identification is concerned, the passive structure [see Fig. 1(b)] is characterized through its scattering matrix  $\underline{S}$  computed by means of electromagnetic simulation on the basis of layout geometry and material parameters (usually available from the design rules and provided by the foundry). Thus, since electromagnetic propagation and coupling effects are accounted for by the passive structure, all the active slices are described by the same three-port scattering matrix  $\underline{\beta}_{AS}$ , which can be identified, as will be shown in the following, once the scattering matrix  $\underline{S}$  of the whole electron device has been measured. It is worth noting that model identification does not require either parameter optimization or complex measurements.

Clearly, in the identification procedure outlined above, the important assumption is made that current transport along the channel does not substantially affect the characterization of electromagnetic-field distribution in the passive structure. In particular, just undoped GaAs was assumed to be under the metal structure. Moreover, also having the active part of the electron device “concentrated” into a limited finite number of active slices, clearly represents an approximation.<sup>4</sup> These simplifications, which make it possible to use a conventional commercially available electromagnetic simulator for model identification, cannot be easily justified by purely theoretical considerations. However, the results provided in the following show that the errors introduced with the above assumptions are not so relevant for electron device scaling. In particular, the next sections will show how an equivalent  $Y$ -matrix per unit width of the electron device can be introduced and used to predict how electrical characteristics scale with gatewidth and number of fingers or, more generally, with device geometry variations.

Considering more in detail the identification of the matrix  $\underline{\beta}_{AS}$ , which describes each of the  $2N$  active slices, we can introduce the vectors  $\vec{a}_i$  and  $\vec{b}_i$ , whose elements are the incident and reflected waves at the ports of the  $i$ th active slice, as shown in Fig. 1(b). The symmetry of the device structure<sup>5</sup> introduces a linear dependence between rows and columns in the scattering matrix  $\underline{S}$  whose dimensions are  $[2 + (2 \cdot 3N)] \times [2 + (2 \cdot 3N)]$ . These rows and columns are eliminated in order to obtain a reduced scattering matrix  $\tilde{\underline{S}}$  whose dimensions are  $[2 + (3N)] \times [2 + (3N)]$ . Moreover,

<sup>4</sup>For these reasons, in the proposed empirical model, the “active slices” do not simply describe the active area of the electron device, but actually include all the errors associated with the above assumptions.

<sup>5</sup>A symmetric structure is very common in all high-frequency devices.

after simple matrix manipulations, it is possible to write

$$\begin{bmatrix} \vec{b}_1 \\ \vec{b}_2 \\ \vdots \\ \vec{b}_{N-1} \\ \vec{b}_N \end{bmatrix} = \tilde{\underline{S}}_1 \cdot \left[ (\underline{\alpha} - \underline{\partial})^{-1} \cdot \underline{\gamma} \right] \cdot \begin{bmatrix} \vec{a}_1 \\ \vec{a}_2 \\ \vdots \\ \vec{a}_{N-1} \\ \vec{a}_N \end{bmatrix} \quad (1)$$

where  $\underline{\alpha}$  is the measured  $2 \times 2$  scattering matrix of the electron device,  $\underline{I}$  is a  $(3N) \times (3N)$  identity matrix and the other matrices are obtained from  $\tilde{\underline{S}}$  according to the following definitions:

$$\begin{aligned} \tilde{\underline{S}}_{i=1, 3 \cdot N; j=1, \dots, 2+3 \cdot N} &= \tilde{\underline{S}}_{i=3, 2+3 \cdot N; j=1, \dots, 2+3 \cdot N} \\ \tilde{\underline{S}}_{i=1, 2; j=1, 2} &= \tilde{\underline{S}}_{i=1, 2; j=1, 2} \\ \underline{\gamma}_{i=1, 2; j=1, \dots, 3 \cdot N} &= \tilde{\underline{S}}_{i=1, 2; j=3, \dots, 2+3 \cdot N} \end{aligned} \quad (2)$$

By noting that [see Fig. 1(b)] the scattering matrix  $\underline{\beta}_{AS}$  associated with each active slice is defined as

$$\vec{a}_i = \underline{\beta}_{AS} \cdot \vec{b}_i, \quad i = 1, \dots, N \quad (3)$$

and defining the matrix  $\underline{M}$  as

$$\underline{M} = \tilde{\underline{S}}_1 \cdot \left[ (\underline{\alpha} - \underline{\partial})^{-1} \cdot \underline{\gamma} \right] \quad (4)$$

it is possible to obtain from (1) a homogeneous system of equations<sup>6</sup>

$$\left( \underline{M}^{-1} - \tilde{\underline{\beta}}_{AS} \right) \cdot \begin{bmatrix} \vec{b}_1 \\ \vec{b}_2 \\ \vdots \\ \vec{b}_N \end{bmatrix} = 0$$

where

$$\tilde{\underline{\beta}}_{AS} = \begin{bmatrix} \underline{\beta}_{AS} & 0 & \cdots & 0 \\ 0 & \underline{\beta}_{AS} & \cdots & 0 \\ \vdots & \vdots & \ddots & \vdots \\ 0 & 0 & \cdots & \underline{\beta}_{AS} \end{bmatrix}. \quad (5)$$

The necessary condition that guarantees the existence of a nonnull solution of system (5) is

$$\det(\underline{M}^{-1} - \tilde{\underline{\beta}}_{AS}) = 0 \quad (6)$$

which can also be written in the form

$$\det(\underline{I} - \underline{M} \cdot \tilde{\underline{\beta}}_{AS}) = 0. \quad (7)$$

This latter is an eigenvalue problem that can be solved in terms of  $\tilde{\underline{\beta}}_{AS}$  by means of different available routines [26].

For operating frequencies that are not extremely high and for electron devices having just two gate fingers, the case  $N = 1$  assumes particular importance, as will be shown in the following. In that case, the solution of (7) is simply

$$\underline{\beta}_{AS} = \underline{M}^{-1}. \quad (8)$$

<sup>6</sup>Equation (5) holds, provided that the matrix  $\underline{M}$  is nonsingular, as happens in practice.

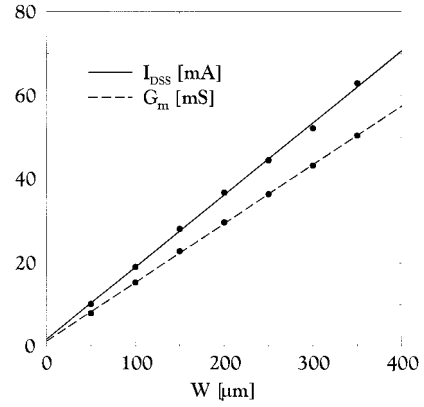

Fig. 2. Linear regression of measured (\*)  $I_{DSS}$  and static transconductance  $G_m$  versus total gate periphery.  $I_{DSS} \cong 1.8 + 0.17 W$  and  $G_m \cong 1.3 + 0.14 W$ .

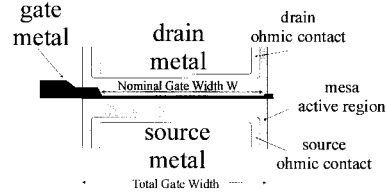

Fig. 3. Layout of a typical gate finger.

### III. SCALING RULES FOR THE ACTIVE SLICES

According to the FET basic theory, it can be reasonably assumed that any nonscalable effect is mainly associated with the passive structure of the electron device, while the intrinsic region can be practically scaled in a proportional way so that for the admittance matrix<sup>7</sup> associated with each active slice, we could write

$$Y_{ASij}(\omega, W_{AS}) = \hat{Y}_{ij}(\omega) \cdot W_{AS}, \quad i, j = 1, \dots, 3. \quad (9)$$

$W_{AS}$  being the active slice width and  $\hat{Y}(\omega)$  the admittance matrix associated with the unitary gatewidth. Unfortunately, experimental results are not in perfect agreement with the above formulation. In particular, it can be easily seen that even DC currents and differential conductances deviate from a simple proportional relation like (9). These deviations, whose entity cannot be simply justified by series parasitic effects (e.g., drain/source metallization resistances), can be clearly observed in Fig. 2, where the saturated drain current and static transconductance are plotted as functions of the total gatewidth for different GEC-Marconi MESFET's of the same wafer die so that process dispersion is practically negligible. From Fig. 2, it is evident that although linear behavior with gatewidth can be reasonably assumed, this is not purely proportional, as the linear regression does not pass through zero. In other words, a zero-width device would have a finite current and transconductance.

A possible justification for this phenomenon could be associated with device areas that are not "homogeneous" from a geometrical point of view, along the finger width. As an example, quite a realistic picture of a MESFET device is shown in Fig. 3; it is evident that the device structure is very

<sup>7</sup>The admittance  $Y_{AS}(\omega, W_{AS})$  associated to the active slice is obtained from the scattering matrix  $\underline{\beta}_{AS}$  by applying simple transformation formulas.

different at the beginning and end of the gate fingers with respect to the intermediate part of the gate structure. These “border-like” effects, which become more relevant at high frequencies, must be accounted for in the scaling rules. A simple way to do this is by introducing, under the reasonable assumption that border effects are independent of device width, a correction term in the value of all the static and dynamic parameters. In particular, an equivalent admittance matrix  $Y_{AS}$  associated to the active slice is defined according to the following scaling rule:

$$Y_{ASij}(\omega, W_{AS}) = \hat{Y}_{ij}(\omega) \cdot W_{AS} + C_{ij}(\omega), \quad i, j = 1, \dots, 3. \quad (10)$$

$C(\omega)$  being a width-independent fraction of the equivalent admittance matrix, which accounts for nonideal border-like effects.

Once the matrices  $\hat{Y}(\omega)$  and  $C(\omega)$  have been identified (on the basis of the matrix  $Y_{AS}(\omega, W_{AS})$  extracted for at least two devices having different gate widths), the linear rule (10) can be used to obtain the equivalent admittance matrix associated with the active slices of a device having a given gatewidth.

#### IV. EXPERIMENTAL RESULTS

Different structures of GaAs MESFET devices, manufactured by GEC-Marconi,<sup>3</sup> were measured and simulated to validate the proposed approach. More precisely, the scattering matrices of the extrinsic passive structures were computed on the basis of foundry geometrical parameters<sup>3</sup> [27] obtained from process rules and device GDSII files, using the “em” Sonnet electromagnetic simulator [27].<sup>8</sup> This is a three-dimensional (3-D) planar simulator based on the method-of-moments formulation. In particular, a submicron grid and quadruple precision were adopted for better accuracy.

The scattering parameters of the electron devices were measured directly on-wafer up to a frequency of 50 GHz using an HP8510C network analyzer. Moreover, the model was implemented in the HP-MDS program for microwave circuit design, according to the scheme shown in Fig. 1(b), using multiport “data-based linear devices.”

In the first modeling step, it is necessary to choose a suitable number of active slices per finger. At the moment, a general *a priori* criterion is not available, but it can be reasonably assumed that the “device slicing” is sufficient, when the normalized response of the active slices is not dependent on their number. Under such conditions, the number of active sections should be large enough to correctly account for distributed effects. As an example, the real and imaginary parts of the transmission parameter  $Y_{21}$ , normalized with respect to the slice width, obtained with a number of one and two active slices per finger, are plotted in Fig. 4 for a  $2 \mu\text{m} \times 150 \mu\text{m}$  GaAs MESFET. It can be observed that despite the relatively long fingers, the difference between the normalized responses is small. As a good compromise between model complexity and accuracy, for the GaAs MESFET’s considered (which are characterized by structures typically adopted in MMIC design)

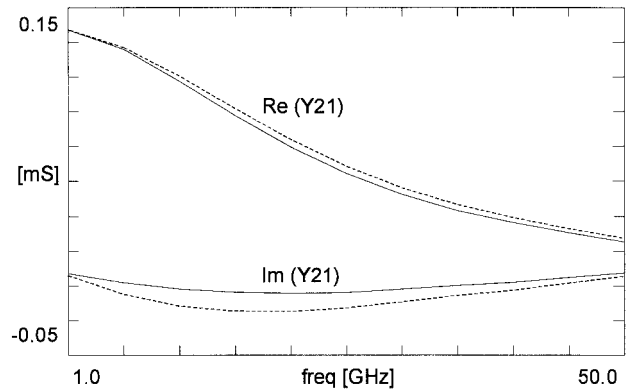

Fig. 4.  $Y_{21}$ -parameter of the active slices normalized with respect to the slice width ( $2 \mu\text{m} \times 150 \mu\text{m}$  FET). Comparison between the case of one (solid lines) and two (dashed lines) active slices.

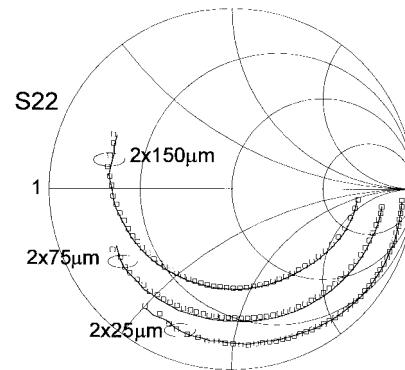

Fig. 5. Measured (box) and simulated (—)  $S_{22}$  for three different MESFET’s.

and up to a frequency of 50 GHz, a model composed of a single active slice per finger was chosen. This choice is also justified by the experimental results provided in the following. The accuracy provided by a single active slice distributed model should not be surprising; in fact, it should be considered that if an electron device is accurately designed for its operating frequency range, the propagation effects along the structure width, and, in particular, signal attenuation, should not be too relevant, otherwise a part of the active area would not be efficiently exploited.

On the basis of the identification procedures proposed in Section II and taking into account the scaling rule introduced in Section III, the admittance matrices  $Y_{AS}(\omega)$  associated with two electron devices having different gatewidths are sufficient to identify the matrices  $\hat{Y}(\omega)$  and  $C(\omega)$  in (10). In practice, since the scaling rule (10) is, in any case, an approximation, we found that better prediction capabilities are obtained by evaluating the matrices  $\hat{Y}(\omega)$  and  $C(\omega)$  on the basis of a linear regression applied to device structures covering a wide range of gatewidths. In particular, model identification was carried out using three MESFET structures: a  $2 \times 25 \mu\text{m}$ , a  $2 \times 7 \mu\text{m}$ , and a  $2 \times 150 \mu\text{m}$  device. Figs. 5 and 6 show the comparison between the measured and simulated  $S_{22}$ - and  $S_{21}$ -parameters for these GaAs MESFET’s. The good agreement confirms the robustness of the proposed approach even when a simple linear regression is adopted for model scaling.

<sup>8</sup>EM Sonnet Software, Inc., Liverpool, NY.

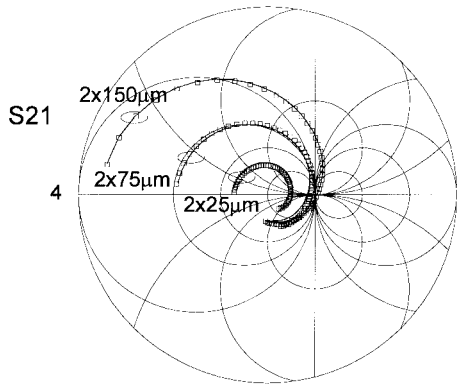

Fig. 6. Measured (box) and simulated (—)  $S_{21}$  for three different MESFET's.

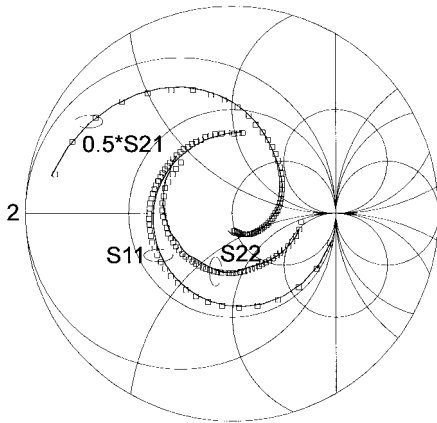

Fig. 7. Measured (box) and predicted (—)  $S_{11}$ ,  $S_{22}$ , and  $S_{21}$  for a  $6 \times 50 \mu\text{m}$  MESFET.

In order to test the actual predictive capabilities of the proposed scaling approach, the model was adopted to predict the electrical behavior of two device structures (a  $4 \times 75 \mu\text{m}$  and a  $6 \times 50 \mu\text{m}$  device) strongly different from those used in the identification phase. Fig. 7 shows the measured and predicted  $S$ -parameters for a  $6 \times 50 \mu\text{m}$  GaAs MESFET.

The excellent agreement found can be better appreciated by observing the prediction of device admittance parameters that, due to the inductive effect associated to the metallizations, show resonant-like peaks at relatively high frequencies. Figs. 8–11 show the real and imaginary parts of the  $Y$ -parameters measured and predicted for the  $4 \times 75 \mu\text{m}$  device. It must be emphasized how the resonant-like sharp behavior, which is normally very sensitive to model errors, is well reproduced.

The good agreement found in the experimental results provided above, and related to the bias condition  $V_{ds} = 3 \text{ V}$ ,  $I_D = I_{DSS}$ , was also found for different bias points. As an example, Fig. 12 shows, for other bias conditions, the measured and predicted real and imaginary parts of  $S_{21}$  for the  $6 \mu\text{m} \times 50 \mu\text{m}$  device.

### V. MAIN FEATURES OF THE NEW APPROACH AND APPLICATION IN HIGH-DENSITY MMIC DESIGN

It is worth discussing the main features and differences of the proposed approach for FET model scaling with respect

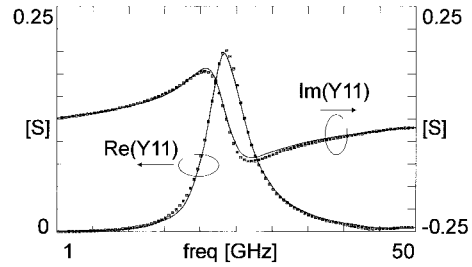

Fig. 8. Measured (box) and predicted (—)  $Y_{11}$  for a  $4 \times 75 \mu\text{m}$  MESFET.

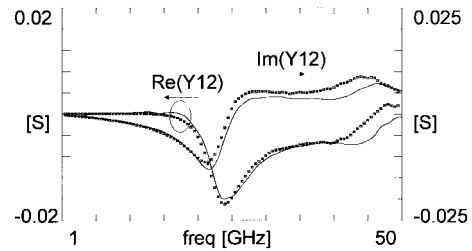

Fig. 9. Measured (box) and predicted (—)  $Y_{12}$  for a  $4 \times 75 \mu\text{m}$  MESFET.

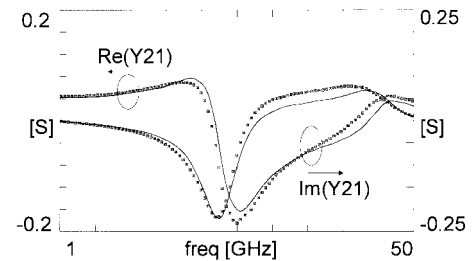

Fig. 10. Measured (box) and predicted (—)  $Y_{21}$  for a  $4 \times 75 \mu\text{m}$  MESFET.

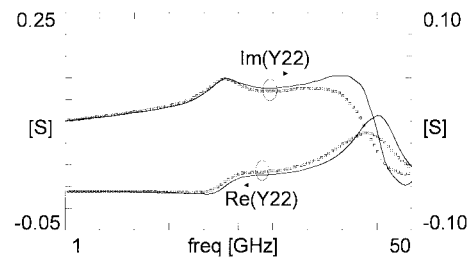

Fig. 11. Measured (box) and predicted (—)  $Y_{22}$  for a  $4 \times 75 \mu\text{m}$  MESFET.

to conventional scaling rules based on equivalent circuits. A part from complex purely empirical approaches based on a large database of measurements on different device structures, the equivalent-circuit approach requires very accurate parasitic modeling [4] in order to enable simple and robust scaling rules based on device geometry to be used for the intrinsic active device. Even under such conditions, however, it is not easy to define how the parasitic networks, which especially at high frequencies represent an oversimplified description of complex electromagnetic phenomena, scale with device geometry (in particular, with the gate finger number).

In the new approach proposed in this paper, the problem above is overcome by using electromagnetic simulations to characterize the electromagnetic behavior of the extrinsic part

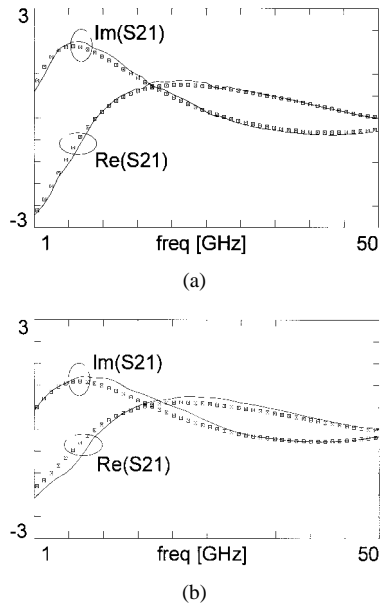

Fig. 12. Measured (box) and predicted (—) real and imaginary part of  $S_{21}$  for a  $6 \times 50 \mu\text{m}$  MESFET. Bias conditions: (a)  $V_{ds} = 3 \text{ V}$ ,  $I_d = 0.5 * I_{dss}$  and (b)  $V_{ds} = 3 \text{ V}$ ,  $I_d = 0.1 * I_{dss}$ .

of the electron device. The experimental results provided in the previous section show that this approach is accurate enough to identify an equivalent admittance description of the active slices that can be scaled according to a simple linear rule.

It must be outlined that the new approach does not require numerical optimization routines. Moreover, the experimental results seem to confirm the model robustness, as its identification can be carried out on the basis of a limited number of measurements on a few different FET structures. As far as the electromagnetic simulation of the electron device layout is concerned, this is not a particularly complex task when using modern electromagnetic tools and workstations.

The implementation of the model in any software tool for nonlinear circuit analysis based on harmonic-balance techniques [28], [29] is straightforward.

One of the main features of the presented approach is that it can be directly applied for a “global approach” to MMIC circuit design where complex electromagnetic effects are taken into account. The example provided in the following is intended only to emphasize this aspect. Experimental validation, which requires strong interaction with a GaAs foundry, will be the object of future work.

On the circuit level, the predictive capabilities of the model also lead to the possibility of analyzing high-density integrated circuits, which may consist of nonconventional configurations where active and passive devices are closely spaced to allow for low production costs. As an example, the self-bootstrapped amplifier, shown in Fig. 13(a), which is widely used in low-cost components for wireless application (see, e.g., the MGA-86 563 manufactured by Hewlett-Packard)<sup>9</sup> has been considered.

In Fig. 13(b), a possible high-density layout of the amplifier is shown, which allows for a drastic reduction of the occupied

<sup>9</sup>Hewlett-Packard Communication Components, GaAs MMIC’s products: MGA-865xx Series, 1997.

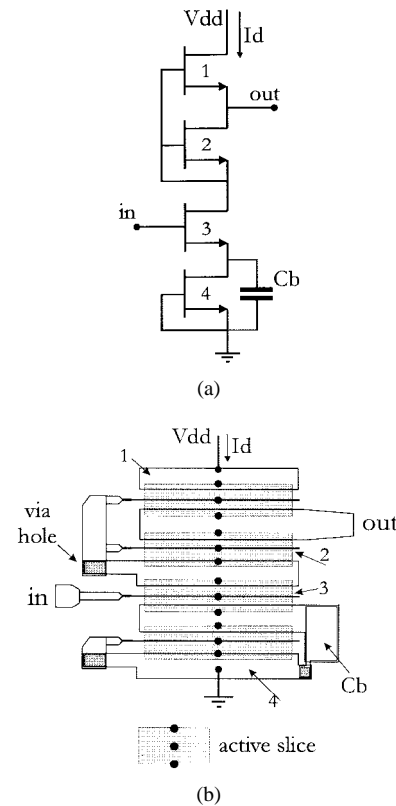

Fig. 13. Self-bootstrapped amplifier. (a) Circuit schematic. (b) High-density layout.

area with respect to conventional arrangements. These, in fact, normally keep wider spacing of the active devices, which are interconnected with transmission lines, according to the foundry design rules.<sup>2, 3</sup>

The objective of this example is to compare the performance of this highly integrated amplifier, predicted using the new approach, with the performance predicted using conventional analysis, based on foundry models, which does not account for coupling effects. In particular, the active area of the amplifier has been characterized using the standard MESFET structures and the procedure described in the previous section, while the scattering matrix of the amplifier extrinsic structure was characterized by using the SONNET electromagnetic simulator.

In Fig. 14, the results obtained for the highly integrated amplifier, using the new approach and conventional analysis, are shown. Concerning the transmission coefficient, it is possible to observe that coupling effects are responsible for a slightly lower magnitude on the whole frequency range, while for the input and output reflection coefficients, more evident modifications arise. It is worth noting how important differences in the circuit response are present, due to the device coupling, also at the relatively low frequency of 1 GHz. Further analyses could also consider the influence of the matching and feedback networks. Moreover, the model could be linked to electromagnetic optimization routines using the approaches proposed in [30] and [31].

The procedure adopted above to simulate a new high-density integrated structure, can obviously be applied to simulate other

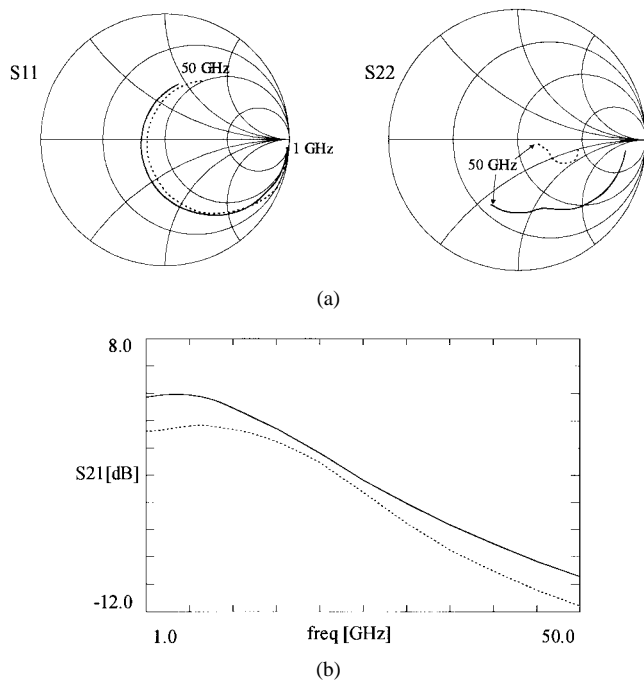

Fig. 14. Performance of the self-bootstrapped amplifier. Comparison between conventional analysis (—) and the new approach (- - -) based on electromagnetic simulation.

MMIC layouts also taking into account the interaction with the active devices.

## VI. CONCLUSION

A distributed approach to the modeling of microwave and millimeter-wave FET's has been proposed, with the aim of providing an accurate and efficient tool for device scaling and/or performance prediction of circuit layout structures, taking into account active devices.

The modeling approach is based on accurate electromagnetic simulation of the electron device metallizations which, in conjunction with  $S$ -parameter measurements performed for a limited number of electron devices, allows for the characterization of the active part in terms of an equivalent admittance matrix that is consistent with linear scaling rules.

Experimental results provided for different MESFET structures confirm the accuracy of the proposed approach. An example of application to the analysis of a highly integrated MMIC has also been presented.

The small-signal scalable distributed model described above may represent the starting point for the identification of a nonlinear FET model and the extension of the proposed approach to nonlinear MMIC analysis based on electromagnetic simulation. To this end, mathematical black-box approaches, such as those proposed in [32]–[35], can quite easily be adopted. Otherwise, it is obviously possible to use a suitable nonlinear equivalent-circuit structure to model the active slices. Future work will be devoted to this subject.

## ACKNOWLEDGMENT

The authors wish to thank Prof. F. Filicori for useful discussions and helpful suggestions.

## REFERENCES

- [1] F. Filicori, G. Ghione, and C. U. Naldi, "Physics-based electron device modeling and computer-aided MMIC design," *IEEE Trans. Microwave Theory Tech.*, vol. 40, pp. 1333–1352, July 1992.
- [2] K. C. Gupta, "Emerging trends in millimeter-wave CAD," *IEEE Trans. Microwave Theory Tech.*, vol. 46, pp. 747–755, June 1998.
- [3] S. M. S. Imtiaz and S. M. El-Ghazaly, "Global modeling of millimeter-wave circuits: Electromagnetic simulation of amplifiers," *IEEE Trans. Microwave Theory Tech.*, vol. 45, pp. 2208–2216, Dec. 1997.
- [4] V. Cojocar and T. Brazil, "Scalability of DC/AC nonlinear dispersion models for microwave FET's," in *IEEE MTT-S Symp. Dig.*, 1997, pp. 387–390.
- [5] W. Heinrich, "On the limits of FET modeling by lumped elements," *Electron. Lett.*, vol. 22, no. 12, pp. 630–632, June 1986.
- [6] G. Ghione and C. U. Naldi, "Modeling and simulation of wave propagation effects in MESFET devices based on physical models," in *Proc. 17th ESSDERC*, Bologna, Italy, 1987, pp. 317–320.
- [7] W. Heinrich, "Distributed equivalent-circuit model for traveling-wave FET design," *IEEE Trans. Microwave Theory Tech.*, vol. MTT-35, pp. 487–491, May 1987.
- [8] J. P. Mondal, "Distributed scaling approach of MESFET's and its comparison with lumped-element approach," *IEEE Trans. Microwave Theory Tech.*, vol. 37, pp. 1085–1090, July 1989.
- [9] T. M. Martin-Guerrero and C. Camacho-Penalosa, "Nonlinearities in a MESFET distributed model," in *Int. J. Microwave and Millimeter-Wave Computer Aided Eng.*, vol. 6, no. 4, pp. 243–248, 1996.
- [10] B. Castillo, T. Martin-Guerrero, and C. Camacho-Penalosa, "Scalable distributed model for microwave and millimeter-wave monolithic FET-type devices," in *5th European Gallium Arsenide and Related III-V Compounds Applicat. Symp.*, Bologna, Italy, Sept. 1997.
- [11] R. Hajji and F. M. Ghannouchi, "Small-signal distributed model for GaAs HBT's and  $S$ -parameter prediction at millimeter-wave frequencies," *IEEE Trans. Electron Devices*, vol. 44, pp. 723–732, May 1997.
- [12] B. Mallet-Guy, Z. Ouarch, M. Prigent, R. Quere, and J. Obregon, "Direct extraction of a distributed nonlinear FET model from pulse  $I$ - $V$ /pulsed  $S$ -parameter measurements," *IEEE Microwave Guided Wave Lett.*, vol. 8, pp. 102–104, Feb. 1998.
- [13] P. Ciampolini, F. Mezzanotte, L. Roselli, and R. Sorrentino, "Accurate and efficient circuit simulation with lumped-element FDTD technique," *IEEE Trans. Microwave Theory Tech.*, vol. 44, pp. 2207–2215, Dec. 1996.
- [14] A. Cidronali, G. Collodi, G. Leuzzi, and G. Manes, "Numerical analysis of a 0.2  $\mu$ m AlGaAs/GaAs HEMT including electromagnetic effects," in *IEEE Int. Symp. Compound Semiconductors*, San Diego, CA, Sept. 7–11, 1997.
- [15] P. Ciampolini, L. Roselli, and G. Stopponi, "Mixed-mode simulation with full-wave analysis of interconnections," *IEEE Trans. Electron Devices*, vol. 44, pp. 2098–2105, Nov. 1997.
- [16] S. M. S. Imtiaz and S. M. El Ghazaly, "Performance of MODFET and MESFET: A comparative study including equivalent circuits using combined electromagnetic and solid-state simulator," *IEEE Trans. Microwave Theory Tech.*, vol. 46, pp. 1456–1464, July 1998.
- [17] M. A. Alsunaidi, S. M. S. Imtiaz, and S. M. El-Ghazali, "Electromagnetic wave effects on microwave transistors using a full-wave time domain model," *IEEE Trans. Microwave Theory Tech.*, vol. 44, pp. 799–808, June 1996.
- [18] A. Cidronali, G. Avitabile, G. Collodi, and G. Manes, "A distributed MESFET CAD model for large signal circuit analysis," in *4th Int. Workshop Integrated Nonlinear Microwave Millimeter-Wave Circuits*, Duisburg, Germany, Oct. 10–11, 1996.
- [19] A. Cidronali, G. Collodi, G. Vannini, A. Santarelli, and G. Manes, "Small-signal distributed FET modeling through electromagnetic analysis of the extrinsic structure," in *IEEE MTT-S Symp. Dig.*, Baltimore, MD, June 1998.
- [20] R. H. Jansen, "Full-wave analysis and modeling for CAD of mm-wave MMIC's," *Alta Freq.*, vol. LVIII, no. 5–6, pp. 551–558, 1989.
- [21] R. H. Jansen and P. Pogatzki, "Nonlinear distributed modeling of multifinger FET's/HEMT's in terms of layout-geometry and process-data," in *Proc. 21st European Microwave Conf.*, Stuttgart, Germany, 1991, pp. 609–614.
- [22] E. Larique, S. Mons, D. Baillargeat, S. Verdeyme, M. Aubourg, P. Guillon, and R. Quere, "Electromagnetic analysis for microwave FET modeling," *IEEE Microwave Guided Wave Lett.*, vol. 8, pp. 41–43, Jan 1998.
- [23] S. Ooms and D. De Zutter, "The anticircuit concept for the characterization of active circuit using electromagnetic simulation," *IEEE Trans. Microwave Theory Tech.*, vol. 44, pp. 2032–2038, Nov. 1996.



- [24] J. Kunisch and I. Wolff, "The compression approach: A new technique for the analysis of distributed circuits containing nonlinear elements," in *IEEE MTT-S Workshop WSK*, 1992, pp. 18–31.
- [25] G. Avitabile, A. Cidronali, G. Vannini, and G. Manes, "Multifinger effect in GaAs FET distributed large signal CAD model," in *IEEE Int. Electron Devices Meeting*, San Francisco, CA, Dec. 8–11, 1996.
- [26] Y. Saad and M. H. Schultz, "GMRES: A generalized minimal residual algorithm for solving nonsymmetric linear systems," *SIAM J. Sci. Stat. Comput.*, vol. 7, pp. 856–869, 1986.
- [27] G. Avitabile, A. Cidronali, and C. Salvador, "Equivalent circuit model of GaAs MMIC coupled planar spiral inductor," *Int. J. Microwave Millimeter-Wave Computer Aided Design*, vol. 7, no. 4, pp. 318–326, 1997.
- [28] F. Filicori and V. A. Monaco, "Computer-aided design of nonlinear microwave circuits," *Alta Freq.*, vol. LVII, no. 7, pp. 353–378, 1988.
- [29] M. B. Steer, "Simulation of nonlinear microwave circuits—An historical perspective and comparisons," in *IEEE MTT-S Dig.*, 1991, pp. 599–602.
- [30] J. W. Bandler, R. M. Biernacki, S. Hua Chen, and Y. F. Huang, "Design optimization of interdigital filters using aggressive space mapping and decomposition," *IEEE Trans. Microwave Theory Tech.*, vol. 45, pp. 709–711, May 1997.
- [31] J. W. Bandler, R. M. Biernacki, S. Hua Chen, L. W. Hendrick, and D. Omeragic, "Electromagnetic optimization of 3-D structures," *IEEE Trans. Microwave Theory Tech.*, vol. 45, pp. 770–779, May 1997.
- [32] F. Filicori, G. Vannini, and V. A. Monaco, "A nonlinear integral model of electron devices for HB circuit analysis," *IEEE Trans. Microwave Theory Tech.*, vol. 40, pp. 1456–1464, July 1992.
- [33] F. Filicori, G. Vannini, A. Santarelli, A. Mediavilla, A. Tazon, and Y. Newport, "Empirical modeling of low-frequency dispersive effects due to traps and thermal phenomena in III–V FET's," *IEEE Trans. Microwave Theory Tech.*, vol. 43, pp. 2973–2981, Dec. 1995.
- [34] G. Vannini, F. Filicori, and A. Santarelli, "Integral approaches to nonlinear modeling of electron devices," presented at the MTT-S Symp. Workshop Nonlinear Measurements Modeling, Denver, CO, 1997.
- [35] ———, "A finite-memory nonlinear model for microwave electron devices," in *Proc. 27th European Microwave Conf.*, Sept. 1997.



**Alessandro Cidronali** (M'98) was born in Florence, Italy, in 1965. He received the Laurea and Ph.D. degrees in electronic engineering from the University of Florence, Florence, Italy, in 1992 and 1998, respectively.

In 1993, he joined the Department of Electronics Engineering, University of Florence, where he became a Research Fellow in 1998. His research activities include passive compact structures for MMIC's, the design of multifunction MMIC's for wireless applications, computer-aided design (CAD) and numerical modeling of GaAs MESFET's, and pseudomorphic high electron-mobility transistor (pHEMT) electron devices, and high-speed front end for direct acquisition of microwave signals. He is currently working on basic research on low-dimensional electron devices and the analysis of quantum electron devices and their applications.

Dr. Cidronali is a member of the Microwave Engineering Center for Space Applications.



**Giovanni Collodi** was born in Florence, Italy. He received the electronic engineering degree in 1996, and is currently working toward the Ph.D. degree in electronic engineering at the University of Florence, Florence, Italy

Following graduation, he joined the Microelectronic Laboratory, Electronic Engineering Department, University of Florence, where he was involved in the field of MMIC and millimeter-monomolithic integrated-circuit (MMMIC) application. He is currently with the Department of Electrical Engineering, University of Firenze, Firenze, Italy. His main interests concern the characterization and modeling of devices for MMMIC and MMIC application, which includes circuit design. In this past year, he began an interest in the field of quantum electron devices.



**Giorgio Vannini** (S'87–M'92) was born in Cittàdi Castello, Perugia, Italy, in 1960. He received the Laurea degree in electronic engineering and the Ph.D. degree in electronic and computer science engineering from the University of Bologna, Bologna, Italy, in 1986 and 1992, respectively.

In 1992, he joined the Dipartimento di Elettronica, Informatica e Sistemistica (DEIS), University of Bologna, as a Research Associate. Since 1994, he has also been with the CSITE, Italian Research Council, Bologna, Italy, where he is responsible for MMIC testing and the CAD Laboratory. Since November 1998, he has been an Associate Professor on the Faculty of Engineering, Dipartimento di Ingegneria, University of Ferrara, Ferrara, Italy. During his academic career, he has taught courses in applied electronics, electronics for telecommunications, and industrial electronics. His research activity is mainly devoted to electron device modeling, CAD techniques for MMIC's, and nonlinear circuit analysis and design.



**Alberto Santarelli** (M'96) was born in Ferrara, Italy, in 1965. He received the Laurea degree in electronic engineering and the Ph.D. degree in electronics and computer science from the University of Bologna, Bologna, Italy, in 1991 and 1997, respectively.

In 1997, he joined CSITE, Italian National Research Council, Bologna, Italy, as a Research Associate. During his academic career, he has been a Lecturer in applied electronics and electronics for telecommunications courses. His main interests are in the fields of nonlinear modeling of microwave devices and circuit design techniques for nonlinear microwave applications.



**Gianfranco Manes** was born in Florence, Italy, on November 16, 1944. He received the Dr. degree from the University of Pisa, Pisa, Italy.

Following graduation, he joined the Electronic Engineering Department, University of Florence, Florence, Italy, where he is currently a Full Professor of applied electronics. He has been active in different research areas, including surface-acoustic-wave technology, signal processing with application to RADAR and ECM, ultrasound beam forming, and Doppler analysis with application to ecographic system for medical diagnosis. He has led national and international research projects, including EC ESPRIT Projects and is currently Project Manager for European projects in the field of information technology. He currently heads the Microelectronics Laboratory, Electronic Engineering Department, University of Florence, Florence, Italy, which is involved in research in microwave and millimeter-wave electron device characterization, and MMIC design and analysis of quantum electron devices and their applications.

Prof. Manes is a member of the Microwave Engineering Center for Space Applications.