



UNIVERSITÀ  
DEGLI STUDI  
FIRENZE

# FLORE

## Repository istituzionale dell'Università degli Studi di Firenze

### **Fighting cheaters: how and how much to invest**

Questa è la Versione finale referata (Post print/Accepted manuscript) della seguente pubblicazione:

*Original Citation:*

Fighting cheaters: how and how much to invest / J.C. NUNO; M. PRIMICERIO; M.A. HERRERO. - In:  
EUROPEAN JOURNAL OF APPLIED MATHEMATICS. - ISSN 0956-7925. - STAMPA. - 21:(2010), pp. 459-478.  
[10.1017/S0956792510000094]

*Availability:*

This version is available at: 2158/373339 since:

*Published version:*

DOI: 10.1017/S0956792510000094

*Terms of use:*

Open Access

La pubblicazione è resa disponibile sotto le norme e i termini della licenza di deposito, secondo quanto stabilito dalla Policy per l'accesso aperto dell'Università degli Studi di Firenze  
(<https://www.sba.unifi.it/upload/policy-oa-2016-1.pdf>)

*Publisher copyright claim:*

(Article begins on next page)

## Fighting cheaters: How and how much to invest

Juan Carlos Nuño<sup>1</sup>, Miguel A. Herrero<sup>2</sup> and Mario Primicerio<sup>3</sup>

<sup>1</sup> Departamento de Matemática aplicada a los recursos naturales, ETSI de Montes, Universidad Politécnica de Madrid, 28040-Madrid, Spain

<sup>2</sup> Departamento de Matemática Aplicada. Facultad de Ciencias Matemáticas. Universidad Complutense de Madrid, 28040 Madrid, Spain

<sup>3</sup> Dipartimento di Matematica "Ulisse Dini". Università degli Studi di Firenze, 55015 Firenze, Italy

November, 20. 2009 (Florence)

### Abstract

Human societies are formed by different socio-economical classes which are characterized by their contribution to, and their share of, the common wealth available. Cheaters, defined as those individuals that do not contribute to the common wealth but benefit from it, have always existed, and are likely to be present in all societies in the foreseeable future. Their existence brings about serious problems, since they act as sinks for the community wealth and deplete resources which are always limited and often scarce.

To fight cheaters, a society can invest additional resources to pursue one or several aims. For instance, an improvement in social solidarity (e.g. by fostering education) may be sought. Alternatively, deterrence (e.g. by increasing police budget) may be enhanced. Then the following questions naturally arise: (i) how much to spend and (ii) how to allocate the expenditure between both strategies above. This paper addresses this general issue in a simplified setting, which however we believe of some interest. More precisely, we consider a society constituted by two productive classes and an unproductive one, the cheaters, and proposes a dynamical system that describes their evolution in time. We find it convenient to formulate our model as a three-dimensional ODE system whose variables are the cheater population, the total wealth and one of the productive social classes. The stationary values of the cheater population and the total wealth are studied in terms of the two parameters:  $\phi$  (how much to invest) and  $s$  (how to distribute such expenditure). We show that it is not possible to simultaneously minimize the cheater population and maximize the total wealth with respect to  $\phi$  and  $s$ . We then discuss the possibility of defining a compromise function to find suitable values of  $\phi$  and  $s$  that optimize

the response to cheating. In our opinion, this qualitative approach may be of some help to plan and implement social strategies against cheating.

## 1 Introduction

Human societies are very complex socio-economical systems whose members are expected to contribute to, and benefit from, a collectively generated pool of resources that we shall term as the common wealth. However, a subclass of the population (the cheaters) provide little, if any, contribution to the common wealth but at the same time take advantage of any welfare that society provides to its members. Cheaters are known to be present in any human society to this day, and since their contribution to the community is merely a negative one, the need arises of keeping their members as low as possible. This last in turn further depletes social resources in order to support policies aimed at controlling such social group.

Concerning control measures, one can roughly distinguish two different strategies: (A) To foster education and social awareness, and (B) To pursue cheaters by police forces. Concerning (A), it is widely assumed that improving cultural and educational facilities results in an easier promotion from low-income to high-income classes, which in turn is expected to yield a high proportion of law-abiding, fairly contributing tax payers. However, it should be noticed that upper classes (defined in terms of their income) develop their own ways of cheating (e.g. tax evasion), whose global impact on society may be even higher than that produced by similar attitudes in low-income classes. On the other hand, the need of a police force to check criminality, that can be considered as a particularly important aspect of cheating, is beyond discussion. This fact notwithstanding, maintaining an efficient police force requires of considerable resources. Clearly, implementing (A) and (B), or any suitable combination thereof, requires of adequate public spending. Thus, the following questions naturally arise:

a) Given that the budget available is limited, which fraction of the total wealth should be devoted to fight cheating? It would be paradoxical indeed to spend more on that purpose than the actual losses generated by cheating itself. On the other hand, an insufficient effort in that direction may result in a social perception of immunity, while at the same time preventing such funds from being used for other social purposes.

b) How should the extra budget be distributed among strategies (A) and (B) above? Note that such choices are unlikely to be equivalent neither in terms of political clout nor in what

concerns estimated costs of measures required to implement them. Moreover, the choice of a distribution among (A) and (B) is not independent of the extra expenditure. In other words, the efficiency of this allocation depends on the budget.

c) Which ultimate goal should one look for: to keep cheaters at their lower possible level, or to ensure the higher possible global wealth? As it turns out, both aims may not be compatible, since a low cheater population might be only kept at the price of a huge, maybe unaffordable, economical effort. A reasonable compromise, defined in terms of a suitable pay-off function, could be preferred by decision makers.

In an attempt to shed light on these questions, we shall discuss in this work a simple mathematical model, which however displays some of the features recalled above. It can be considered in the same spirit as the model we have presented in [15], where a criminal-prone self protected society divided into  $n$  different socio-economical classes (defined in terms of their contribution to the total wealth) was considered. As in [15], we shall deal with a system of Ordinary Differential equations (ODEs), thus assuming continuous variables (e.g. relative population of each species) that depend on time. This approach seems appropriate to model the dynamics of large human populations, where births and deaths take part nearly continuously. This is in sharp contrast with other types of populations, where growth occurs in discrete generations, whence models based on Difference Equations should be more adequate (see, for instance, [12]).

Since we shall consider ODEs models, we will assume that the populations under consideration are homogeneous in space. While we intend to include space dependence in future work, we retain the space homogeneous case to be of some interest on its own, as we will explain below. Also, our model is a deterministic one, and it therefore ignores random fluctuations in the dynamics considered. A feature that we will deal with herein is strategy optimization, so that quantitative arguments to assess the comparative weight of strategies (A) and (B) above on policy making will be discussed.

This paper is organized as follows: Section 2 contains a brief description of population models relevant to our forthcoming analysis. The particular two-classes model that we will discuss in detail herein is presented in Section 3. Section 4 is concerned with an optimization problem formulated for the dynamical system defined in the previous section. A sensitivity analysis is carried out in section 5 to check the robustness of the model. Finally, we discuss

on the results obtained and on possible extensions thereof that could incorporate more general social situations. We have confined to appendices some technical (although simple) details not to discourage non-mathematicians to read the core of the paper, that is mainly intended to stimulate discussion on modelling issues.

## 2 A population dynamics approach

Population models have fostered a huge amount of mathematical research in the last two centuries. In the XIX century, two famous mathematical models were brought about in an attempt to understand the evolution of human populations. We are referring to the Malthus law and the Verlhust or logistic equation (see, for instance, [19]). A second great burst of mathematical modelling occurred at the beginning of the XX century with the publication of the so called Lotka-Volterra equations to study predator-prey systems (a good introduction to these models can be found in [12, 9]). Nonetheless, despite the relevance of population models in the natural sciences, its application in sociology and, in particular in criminality, seems to have been comparatively scarce. Only in recent years, models based on population dynamics have been proposed in this field. In this framework, a typical example can be roughly described as follows: a closed society in which spatial differences are neglected is assumed to be composed by different classes of individuals characterized by their attitudes towards illegal behaviour. The influences among the different classes, the flow from one class to another, etc... are then introduced, and the corresponding social dynamics is studied by analyzing the properties of the solution of a system of Ordinary Differential Equations (ODEs).

To be more specific, we briefly describe a few examples of population models applied to study criminal behaviour. Recently, Paul Ormerod and his collaborators used this approach to measure how crime evolves over time in terms of socio-economical factors, as a consequence of agent interactions [16, 3, 2]. In its simplest form, the population is divided into three groups according to the propensity to commit crimes: Non-susceptible, susceptible and hard-core criminals. The corresponding mathematical model accounts for the main factors that drive the flux among these classes (basically, demography, overall social and economical conditions, as well as the deterrence effect of the justice system). The values of the parameters entering the model are calibrated with actual data for a given class of crimes in a given region, so that not only the existing data are fitted, but the results of the simulations can suggest how the

society will react to particular changes in socio-economical factors (e.g. increasing deterrence or increasing the imprisonment period). In latter versions of the model other classes are considered: prisoners [3] and "recovered" (the analogy with epidemiological models is evident) [23]. In the latter, the subpopulation of recovered criminals is subsequently split between non-susceptible and susceptible, and additional nonlinear effects are taken into account.

Other models are much closer to the ecological framework and introduce phenomena similar to biological interactions as symbiosis, competition or predator-prey behaviours. For instance in [1] the "symbiosis" between drug smugglers and drug consumers is considered. The Poincaré-Bendixon theorem is then used to exclude the existence of limit cycles, and the influence of the parameters of the model on the equilibria of the dynamical system is studied. Predator-prey models have been proposed to describe the interactions between policemen (predators) and criminals (preys) [20]. The classical Lotka-Volterra model is modified to include induced changes due to, for instance, policy measures or law enforcement.

An additional level of predation is studied in the "triangular" model [14]. Criminals are predators with respect to the law-abiding people and are preys of guards; but, at the same time, guards have an impact on normal people that have to bear the cost of their salaries, equipment and facilities. The kind of predation guards exert on owners is basically of economical character, and indirectly affects the owners population. Unfortunately, the consideration of these three classes makes the dynamics much more complex and prevents a complete study, though some results can be obtained for particular cases (to explore further this model a mathematica demonstration is found in [18]).

The population models previously presented, which are reminiscent of predator-prey models in ecology, assume that criminal activities act directly on victims and thus modify its population. However, most of the offenses committed in our societies are against property, causing the depletion of individual wealth and, consequently, of the wealth of the whole society. In fact, modern societies not only cared about criminal activities (that worry very much because the induced insecurity feeling) but also about other kind of antisocial behaviour as tax evasion, i.e. the existence of people that do not contribute to a common wealth. The presence of cheaters has been pointed out as one of the causes that prevent cooperation [8]

A special problem in this framework has been tackled in a previous paper [15] where a model of a criminal-prone society divided into  $n$  classes  $I_i$  according with their contribution to

the total wealth  $W$  was defined. It was therein assumed that individuals can move from one class to another depending on the total wealth of the society. The rates of social promotion from class  $i - 1$  to class  $i$  and social relegation from class  $i$  to  $i - 1$  are given by positive real parameters  $\alpha_{i-1}$  and  $\beta_i$ , respectively. Criminals are considered as a class apart, together with a specialized class of guards that is hired by the society to control criminality. More precisely, let us denote the population of each class at time  $t$  by  $X_i(t)$   $i = 1, \dots, n$ . The criminal and guards populations at time  $t$  are given by  $Y(t)$  and  $G(t)$ , respectively. We assume the total population of the society to be constant, i.e.

$$\sum_{i=1}^n X_i(t) + Y(t) + G(t) = N \quad (1)$$

At time  $t$ , each class contributes to the total wealth  $W(t)$  (budget) proportionally to its population:

$$W(t) = \sum_i^n c_i X_i(t) \quad (2)$$

where, for instance,  $c_i \leq c_{i+1}$  for all  $i = 1, 2, \dots, n - 1$  and  $c_1 \geq 0$ . For simplicity, it is also assumed that guards and criminals do not contribute to the legal economy.

In a free-of-criminals society (where police is not necessary yet) the flow of individuals through the social classes is given by:

$$\dot{X}_i(t) = \alpha_{i-1} X_{i-1}(t) - (\alpha_i + \beta_i) X_i(t) + \beta_{i+1} X_{i+1}(t) \quad (3)$$

We take, by definition,  $\alpha_0 = \alpha_n = \beta_1 = \beta_{n+1} = 0$ . It is then straightforward to obtain the equilibrium distribution of individuals among different classes:

$$\begin{aligned} -\alpha_1 X_1 + \beta_2 X_2 &= 0 \\ \alpha_{i-1} X_{i-1} - (\alpha_i + \beta_i) X_i + \beta_{i+1} X_{i+1} &= 0 & i = 2, \dots, n - 1 \\ \alpha_{n-1} X_{n-1} - \beta_n X_n &= 0 \end{aligned} \quad (4)$$

Besides, for any  $t$

$$X_1(t) + X_2(t) + \dots + X_{n-1}(t) + X_n(t) = N \quad (5)$$

where  $N$  is the whole population. In general this is a nonlinear system since the kinetic parameters  $\alpha_i$  and  $\beta_i$  may depend on  $X_1, \dots, X_n$  through  $W$ . It can be proved (see Appendix 1) that, under general assumptions, at least one non-trivial equilibrium point exists.

To take into account the presence of criminals  $Y$ , the scheme has to be modified to include the effect they cause to the distribution of the population, as well as the damage caused to

the total wealth. A new ODE must be introduced to describe the time evolution of  $Y$  that is related to  $W$  and some of the other classes  $X_i$ . The presence of guards  $G$  could also be taken into account by introducing an additional ODE for the evolution of their number, or simply by assuming that  $G$  is given but its value affects the equation of  $W$  (the cost of maintaining a police) in addition to the equation of  $Y$  (see [15] for details).

The mathematical formulation of this kind of models depends on the question to be addressed. In [15] we considered explicitly the effect of crimes in the total wealth and how it can be controlled by the society. It was proved that this kind of systems are criminal-prone, in the sense that criminal-free steady states are unstable under small perturbations in the socio-economical context. Moreover, we compare and quantify two different strategies (increasing police forces versus increasing social measures) to fight criminality (see [15] for further details). In the next section, we present a particular  $W$ -model with only 2 social classes that allow us to go a step further in the study of criminality and how to control it.

### 3 Two classes $W$ -model

$W$ -models in which the total population wealth  $W(t)$  is considered as a variable, are particularly useful to tackle the questions stated at the introduction. Let us assume a society with only two social groups, classified according to their contribution to the common wealth  $W$ , say poor and rich, and a class formed by individuals that do not contribute to  $W$ , the cheaters. For the sake of simplicity, it is assumed that cheaters are recruited just from the poor class and that when they decide not to cheat again (either naturally or by the action of social pressure) they go back to the same class.

Let  $X_1(t)$ ,  $X_2(t)$  and  $Y$  be the population of poor, rich and of cheaters at time  $t$ , respectively. Besides, it is assumed that the total population remains constant, i.e.

$$N = X_1(t) + X_2(t) + Y(t) \tag{6}$$

Let us start by considering a cheater-free society, so that:

$$\begin{aligned} \dot{X}_1 &= -\alpha X_1 + \beta X_2 \\ \dot{X}_2 &= \alpha X_1 - \beta X_2 \end{aligned} \tag{7}$$

$\alpha$  and  $\beta$  being the coefficients of social mobility (promotion and relegation, respectively).



With this definition of the rich class and taking into account the Pareto principle or 20-80 rule (see, for instance, [17]), that establishes that 20 % of the population can be considered rich, it is reasonable to select  $\beta \approx 4\alpha$ . On the other hand, the values of  $\alpha$  and  $\beta$  depend on the mobility we assume in the society. In particular, we choose one in which  $\beta = 0.04$  and  $\alpha = 0.01$ . Of course, these values depend on the choice of the unit of time. If we assume this unit to be 1 year then about 5% of the population changes its social status in 1 year.

These parameters can also depend on the total wealth, as we assumed in [15], because social mobility is sensible to  $W$ . Here we will assume, in particular, that parameter  $\alpha$  may increase because of the social policy adopted.

### 3.1 Equation for the total wealth, $W$

The total budget of the society changes over time because of social mobility. This can be described by the following differential equation:

$$\dot{W} = P - E - (S + G) \quad (8)$$

Here  $P$  is the rate of wealth production. As stated in the previous section, it is quite natural to assume a linear dependence on  $X_1$  and  $X_2$ :

$$P = c_1 X_1 + c_2 X_2 \quad (9)$$

It is convenient to normalize wealth with respect to  $c_1 N$  (i.e. the wealth produced, or the taxes paid, per year by a population in which all the individuals belong to the poor class) and to normalize  $X_1$  and  $X_2$  to the total population ( $z = \frac{X_1}{N}$  and  $u = \frac{X_2}{N}$ ). Thus:

$$\frac{P}{c_1 N} = z + a u \quad (10)$$

The value of constant  $a$  now depends on the definition we take for rich and poor classes. To be specific we assume this definition in agreement with the 20/80 rule ([17]) that states that 20 % of the population owns 80 % of the resources (and hopefully contributes up to the 80 % of the fiscal income). This means that we will take  $a = 16$ .

The term  $E$  is the rate of current expenses (neither related nor influenced by cheating). It is natural to assume that they represent a given fraction of the actual total budget  $W$ , so that:

$$E = \theta W \quad (11)$$

Modern societies tends to adjust its expenses to the GNP so  $\theta$  must be close to 1.

The next term  $S + G$  represents the expenditure per unit time (i.e. 1 year) in order to counteract the growth of cheating. Their sum will be a fraction  $\phi$  of the total wealth. This quantity  $\phi$  must be split into two parts: expenses aimed at social promotion (represented by  $S$ ) and those devoted to crime repression (represented by  $G$ ). We shall write:

$$\begin{aligned} S &= s \phi W \\ G &= (1 - s) \phi W \end{aligned} \tag{12}$$

where  $s \in [0, 1]$ . Thus,  $\phi$  measures "how much a community spends to fight cheating" whereas  $s$  measures "how it spends this amount". In principle,  $\phi$  would depend on  $Y$ , although here it will be considered as a constant. In a quasi-stationary approach it is reasonable to assume that the change of political strategy has a time of reaction that is long with respect to characteristic times of social evolution. This implies that the system always relaxes to a stationary regime between any two consecutive changes of the control parameters  $\phi$  and  $s$ .

Finally, normalizing  $u = \frac{X_2}{N}$ ,  $z = \frac{X_1}{N}$  and  $w = \frac{W}{N c_1}$ , equation 8 reduces to:

$$\dot{w} = z + 16 u - (1 + \phi) w \tag{13}$$

### 3.2 Equation for the cheater population, $Y$

Arguing as in [15], the time evolution of the cheater population can be written as:

$$\dot{Y} = R - D - A \tag{14}$$

where  $R$ ,  $D$  and  $A$  represent recruitment, "natural" decay and arrests, respectively, always referred to the unit of time (1 year). For simplicity, we assume that recruitment comes only from the poor class and that it is a linear function of  $Y$  (taking into account a sort of contagion):

$$R = (\tau_0(w) + \tau_1(w) Y) X_1 \tag{15}$$

We take:

$$\tau_i = \bar{\tau}_i \frac{1}{1 + \eta_i s \phi w} \tag{16}$$

for  $i = 0, 1$  as a way of considering a percentage of the total budget in social promotion to reduce the rate of recruitment.

In the case of constant  $\tau_0$  and  $\tau_1$ , i.e.  $\eta_0 = \eta_1 = 0$  we can argue that  $\tau_0$  is about a few percent, e.g.  $\tau_0 = 10^{-2}$ , whereas  $\tau_1$  is such that the spontaneous passage from  $X_1$  to  $Y$  is of the same order of magnitude as the flow by contagion. Thus, we can take:  $\tau_1 = 10^{-1}$ .

Concerning  $D$  we assume as usual a decay proportional to the population and that about 1% of the cheater population leaves that class in one year:

$$D = \mu Y \quad (17)$$

with  $\mu = 10^{-2}$ .

The last term  $A$  measures the removal of cheaters by the action of guards. We can say that it is proportional to the resources invested in this matter, thus:

$$A = k(1 - s)\phi w Y \quad (18)$$

$k$  represents the efficiency of a policeman (the average fraction of cheaters captured in one year) divided by the equivalent yearly normalized cost. Notice that a stationary value for  $w$  in a cheater-free society ranges from 1 (all poor) to 16 (everybody is rich) and that  $\phi$  would be of the order of  $10^{-2}$ . So, taking  $k = 1$  means that 1 percent of the criminals are caught in 1 year.

To complete the model we have to define the dependence of  $\alpha$  and  $\beta$  on the policy choice for fighting cheating. For simplicity, we assume that  $\beta$  remains constant ( $\beta = 0.04$ ) and that  $\alpha$  can increase due to the amount of money devoted to social measures:

$$\alpha = \alpha_0 + \alpha_1 s \phi w \quad (19)$$

In practice, we will take as before  $\alpha_0 = 0.01$  and  $\alpha_1 = 1$ .

Taking  $y = \frac{Y}{N}$  and considering the constraint  $u + z + y = 1$ , the dynamical system we will analyze in the next section is given by:

$$\begin{aligned} \dot{z} &= -(0.01 + s\phi w)z + 0.04(1 - z - y) - \dot{y} \\ \dot{y} &= (0.01 + 0.1y)z - 0.01y - (1 - s)\phi w y \\ \dot{w} &= z + 16(1 - z - y) - (1 + \phi)w \end{aligned} \quad (20)$$

In appendix 2, we present a related but simpler model with only two classes, tax-payer and cheaters, that exhibits already an interesting behaviour.

First, let us find what is the largest wealth that this society can produce. It can be argued that this will be achieved in the absence of cheaters and when the richest class takes its largest possible value. A free-of-cheaters society is possible only if they can not be recruited from the poor class, i.e.  $\tau_0 = \tau_1 = 0$ . In addition, social promotion is enhanced as much as possible when public expenses are completely devoted to that end, i.e.  $s = 1$ . In this case,  $\bar{y} = 0$  and the total wealth reads:

$$\bar{w} = \frac{-1 + 319\phi + \sqrt{102081\phi^2 - 318\phi + 1}}{40\phi(1 + \phi)} \quad (21)$$

The maximum value of the total wealth is  $\bar{w}_{max} \approx 14.5$  and it is attained for  $\phi = \frac{53}{34027} + \frac{1276}{102081\sqrt{15}} \approx 0.05$ .

When both  $\tau_0$  and  $\tau_1$  are different from zero, then a positive cheater population appears. If no additional expenses are devoted to fight cheating, i.e.  $\phi = 0$ , then the stationary total wealth is drastically reduced to  $\bar{w}_0 \approx 0.45$ . This is about a thirty times drop if compared with  $\bar{w}_{max}$ . The corresponding criminal population reaches  $\bar{y} \approx 0.89$ . This means that almost 90% of the population do not pay taxes (cheaters). However, as we will see in the next section, the losses in the total wealth can be reduced by increasing public expenses  $\phi$ . Nonetheless, this must be carried out adequately, since, in the vain aim at reducing completely the criminal population, the total wealth could be depleted even more than its minimum  $\bar{w}_0$  (in fact,  $\bar{w}$  tends to 0 when  $\phi \rightarrow \infty$ ).

## 4 Qualitative analysis

In this section we are going to analyze the equilibrium properties of the dynamical system (20) in terms of the control parameters  $\phi$  (how much) and  $s$  (how). The equilibrium level of cheaters and the total wealth of the society can be determined by setting equal to zero the right hand side of (20). The resulting algebraic system is non-linear and difficult to be solved analytically. A numerical solution can still be found using standard packages as, for instance, MAPLE. The stationary cheater population turns out to be the solution of a fourth-degree equation. Then the corresponding total wealth can be obtained from it, as can be seen in the Appendix 3.

Figures 1 and 2 show the tridimensional plot for both the cheater population and the total wealth at equilibrium as a function of  $\phi$  and  $s$ . As it can be seen, whereas the cheater population  $\bar{y}$  decreases monotonically with  $\phi$  for all values of  $s$ , the total wealth  $\bar{w}$  presents, for all  $s$ , a peak for a definite value of  $\phi$ .

How this peak depends on  $s$  is not evident. As  $s$  tends to 0 it is displaced to larger values of  $\phi$ . Nonetheless, for  $s = 0$  the maximum is attained for a lower value of  $\phi$  (see figure 3). Looking at the other extreme  $s = 1$ , the displacement is neither monotonous: for  $s = 1$ , the peak is moved again to larger values of  $\phi$ .

These results suggest that to attain the lowest possible level of cheaters, the authorities should increase as much as possible the public spending  $\phi$ . However, this would cause the depletion of the common pool to untenable levels. A possible solution would be to maintain

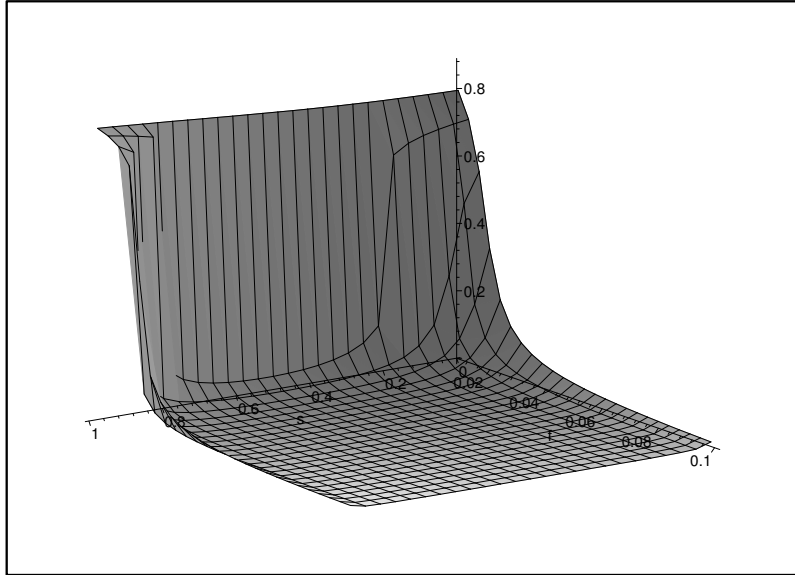

Figure 1: Stationary cheater population as a function of  $s$  and  $\phi$ . The rest of the parameter values are defined in the main text.

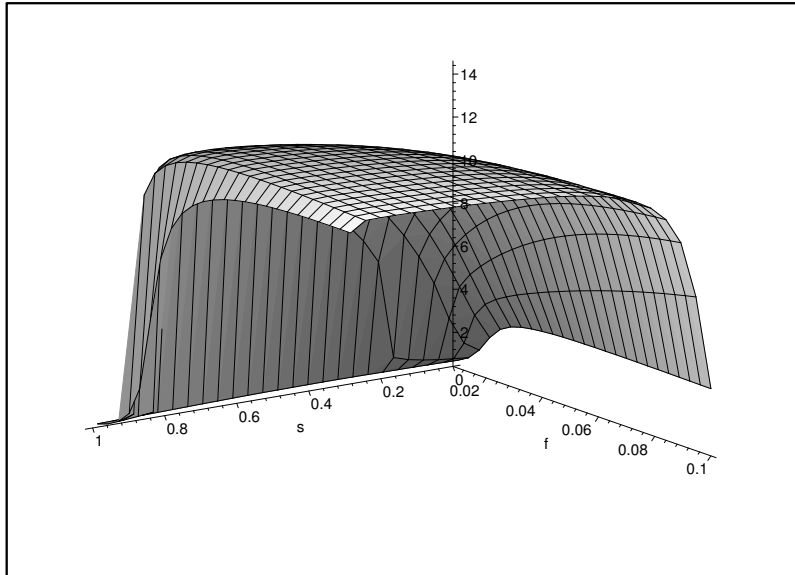

Figure 2: The corresponding stationary total wealth as a function of  $s$  and  $\phi$ . The rest of the parameter values are defined in the main text.

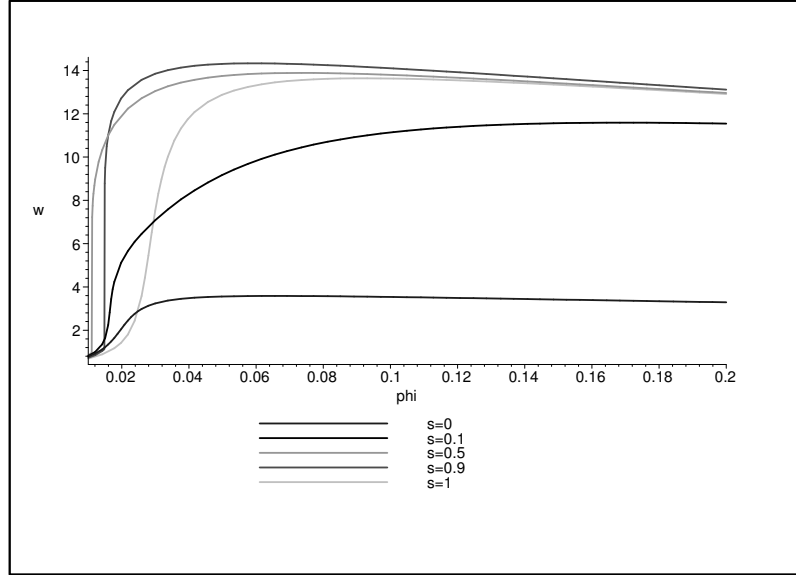

Figure 3: The stationary common wealth as a function of  $\phi$  for different values of  $s$ . As can be seen, all the curve present a peak for a value of  $\phi$  that depends on  $s$ . All the curves approach the horizontal axis as  $\phi$  tends to infinity. The rest of the parameter values are defined in the main text.

the total wealth in its largest value for the couple  $(\phi, s)$ . However, this would force the society to live with a high level of cheaters, maybe neither unsustainable. As stated previously, the question arises about how to get a compromise between these two possibilities.

A standard way of solving this matter is to define a new compromise function from the equilibrium solutions obtained from the dynamical system (20). However, the choice of such a function is not trivial. For instance, the ratio

$$\bar{R} = \frac{\bar{w}}{\bar{y}} \quad (22)$$

that is, the stationary total wealth per cheater, presents an absolute maximum but for a very large value of  $\phi$ . This would mean that to get the largest (allowable) total wealth per cheater the authorities should spend yearly three times the ordinary expenses. Indeed, an unattainable amount.

An alternative approach is to define a set of compromise functions each of them representing a certain distance to an "ideal" and unreachable point (where the two criteria are optimized simultaneously). This idea is behind the compromise programming, mathematically introduced by Yu and Zeleny ([21, 22]). For instance, we can use the Euclidean distance to define:

$$\bar{L} = \sqrt{(\bar{w} - 16)^2 + \lambda \bar{y}^2} \quad (23)$$

Here  $\lambda > 0$  is a normalization factor that allows to weight each criteria differently. Since  $\bar{L}$  is a function of the two parameters  $s$  and  $\phi$ ,  $\bar{L}$  represents the distance from a surface to the "ideal" line  $(1 - \bar{y}, \bar{w}) = (1, 16)$ . Figure 4 depicts a 3-D plot of  $\bar{L}$  as a function of  $s$  and  $\phi$  for  $\lambda = 1$ . As can be seen in this range, the surface decreases sharply with  $\phi$  until it reaches a plateau. An absolute minimum exists for  $s \approx 0.9$  and  $\phi \approx 0.05$ . Moreover, these values are quite insensitive with respect to  $\lambda$ .

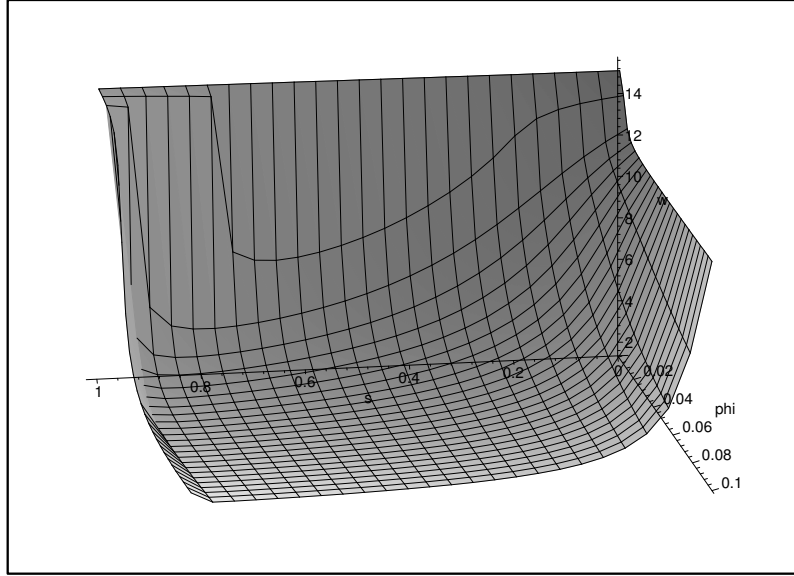

Figure 4: 3D-plot of the stationary compromise function  $\bar{L}$  as function of  $\phi$  and  $s$ . As can be seen,  $\bar{L}$  reaches an absolute minimum at  $(\phi \approx 0.05, s \approx 0.9)$ . Parameter setup as in previous figures

Finally, a less rigorous but useful possibility to be considered by decision makers consists in adjusting  $\phi$  to maximize the largest total wealth, knowing that for this value the cheater population has been well reduced. As a matter of fact, for the couple  $(0.05, 0.9)$  that approximately maximizes the common wealth,  $\bar{w}_{max} \approx 14.5$ , the cheater population is already around 1 percent of the population, i.e.  $\bar{y} \approx 0.01$  (see figures 1 and 2).

## 5 Sensitivity on $k$

Besides the control parameters  $\phi$  and  $s$ , the relationship between the parameter  $k$ , that measures the efficiency of police repression, and  $\alpha_1$  (see equation 19), the efficiency of public spending to foster social promotion, play a fundamental role in the system. In this section, we study how

sensitive the system is when this ratio varies. Let us take  $\alpha_1 = 1$  and let  $k$  be the second control parameter, together with  $s$ , instead of the extra expenditure that is now fixed to  $\phi = 10^{-2}$ .

Figure 5 depicts a 3-D plot of the cheater population as a function of  $s$  and  $k$ . As it can be seen, level curves for fixed  $k$  presents a minimum as a function of  $s$  only when  $k$  is larger than the critical threshold,  $k_c \approx 1.25$ . Below it, there is no trade off in  $s$  and the minimum level of criminality is attained either for  $s = 1$  if  $k < 0.3$  or for  $s = 0$  for  $0.3 < k < k_c$ .

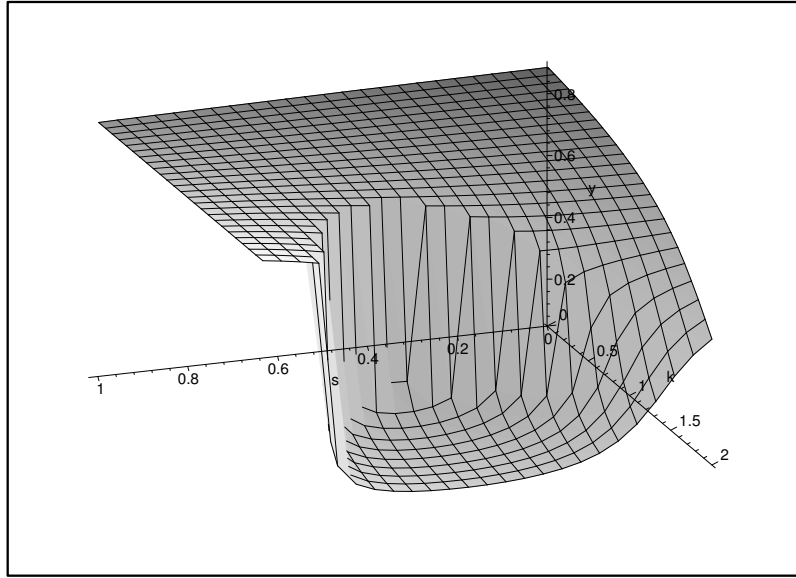

Figure 5: Cheater population  $y$  as a function of  $k$  and  $s$ . As is depicted in figure 5, some of the level curves are not continuous as appear here. Parameter values are:  $\phi = 0.01$ ;  $\alpha_0 = 0.01$ ;  $\alpha_1 = 1$ ;  $\mu = 0.01$ ;  $a = 16$ ;  $\theta = 1$ ;  $\tau_1 = 0.1$ ;  $\tau_0 = 0.01$ ;  $\beta = 0.04$ .

The transition from a higher level of cheaters to a lower one is observed better in figure 6, where several projections for different values of  $s$  are depicted. Transitions become sharper as  $s$  increases towards 1. Nonetheless, if  $s = 1$  the cheater population does not depend on  $k$  ( $\bar{y} \approx 0.87$ ). When projections are on  $k$ , i.e.  $s$  is left to vary for fixed values of  $k$ , a striking result is obtained as shown in figure 7. When  $k$  is less than a critical threshold  $k_c \approx 1.24$  a multistability regime appears for intermediate values of  $s$ ; a lowest level of cheater population coexists with a higher one for a range  $s$  that depends on  $k$ . As  $k$  increases this multistability disappears and the cheater population reaches a plateau  $\bar{y} \approx 0.04$  in the whole  $s$ -interval  $[0, 1]$ . It is important to remark the abrupt increase near  $s = 1$  because for  $s = 1$  the level of cheaters is independent of  $k$  and equals 0.87, approximately.

The total wealth behaves in a similar way, though the thresholds are different (see figure



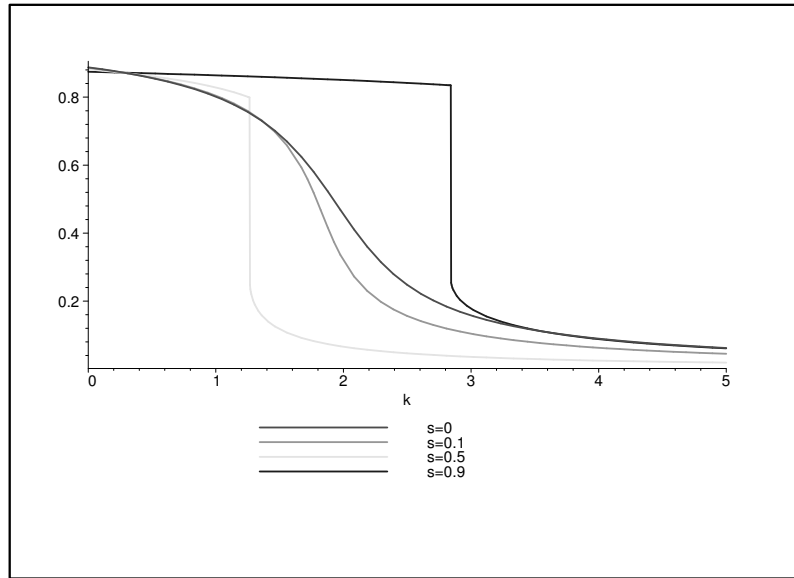

Figure 6: Projections of the cheater population as a function of  $k$  for fixed values of  $s$ . Notice the discontinuities in the solution curves for certain values of  $s$ . The rest of the parameters take the values as in the previous figure

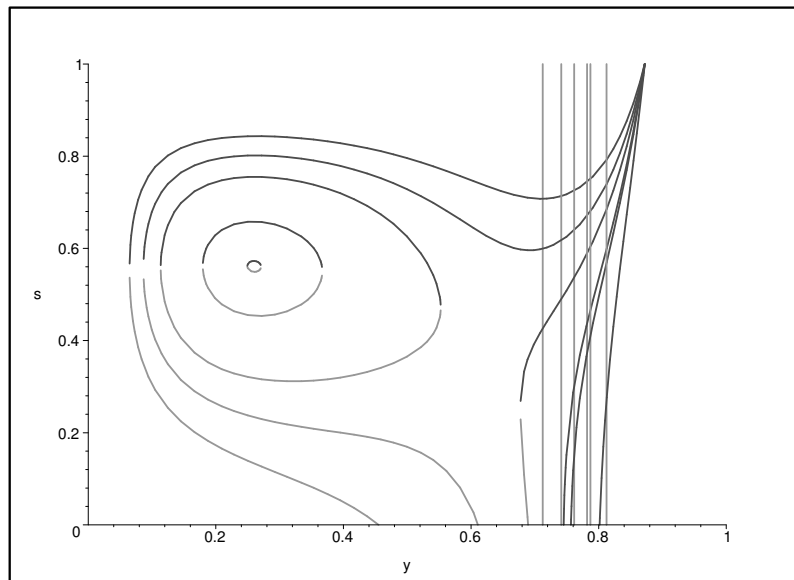

Figure 7: Cheater population as a function of  $s$  for different values of  $k$ . Notice that the representation is inverted:  $\bar{y}$  is in the horizontal axis. As can be seen, for values of  $k > k_c$  a bistability situation exists. Discontinuities are due to numerical resolution. The values of the parameters are as in the previous figures

8). Below  $k_c \approx 0.6$ ,  $W$  increases monotonically with  $s$ . If  $k > k_c$ , then  $W$  reaches a maximum for a particular  $s \in (0, 1)$ .

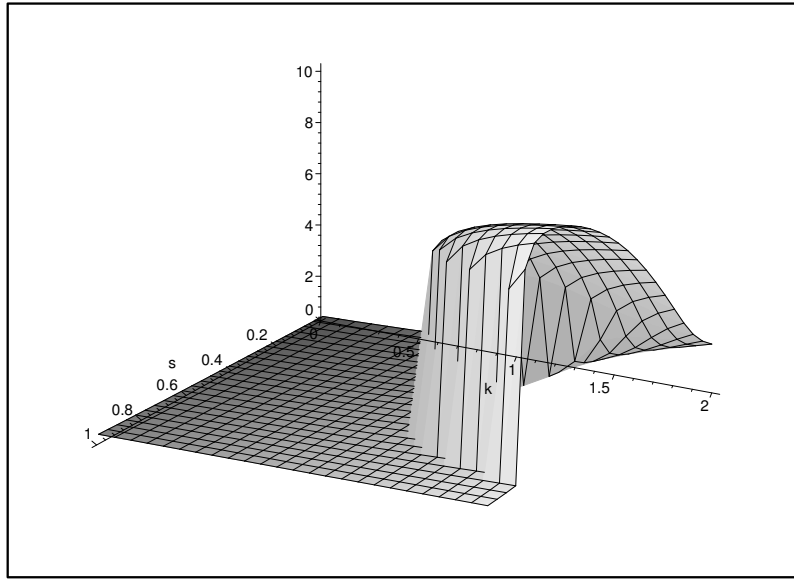

Figure 8: 3D-plot of the total wealth  $\bar{w}$  as a function of  $k$  and  $s$ . Notice the sharp transition to large values when increasing  $k$  that coincides when the abrupt drop in the level of cheaters. As can be seen, this threshold is a function of  $s$ . Parameter values are as in the previous figures

## 6 Discussion

The origin of cooperation in human societies is a fundamental open question [7, 8, 11]. One of the main challenges we face is the explanation of stable societies even in the presence of cheaters, that is individuals that do not cooperate with but take advantage from the group. In pure selective terms, cheaters are better adapted and so they finally would ruin the society (a society full of cheaters is clearly not viable). To control antisocial behaviour, individuals have brought about different strategies, punishment being maybe the most efficient of all [5, 4]. But punishment has a cost that could turn to be, in some situations, comparable to the damage produced by cheaters. It would be paradoxical to spend more money in defending ourselves against cheaters than the losses of having a percentage of the population behaving in an antisocial manner.

This paper has addressed this issue by using a simple mathematical model written in terms of differential equations. The model assumes that the dynamical system responds quickly enough to changes (either internal or external) to be almost permanently in a stationary state.

So, the cheater population and the common wealth are the equilibrium points of the dynamical system. Since, the dynamical system (20) has always an unique stationary state for the given parameter setup, then the equilibrium values of the cheater population  $\bar{y}$  and the total wealth  $\bar{w}$  are objective functions that can admit an optimal solution in terms of two parameters that represent how much to expend ( $\phi$ ) and how to invest this amount ( $s$ ). For the parameter setup we have selected, it turns out that whereas  $\bar{w}$  has a maximum,  $\bar{y}$  is a monotonically decreasing function of  $\phi$  for all values of  $s$ . So, the question of what are the best values of  $\phi$  and  $s$  to choose can not be straightforwardly answered. The best for what? Either to maximize  $\bar{w}$  or to minimize  $\bar{y}$ ? As a matter of fact, in the limit, to minimize the level of cheaters would require the whole wealth of the society. As we said before, it does not seem a clever solution to devote our exhausted resources to get a negligible payoff.

In a preliminary step, to solve this paradox we have studied several compromise functions in section 4. The ratio between the common wealth and the level of cheaters through the function  $\bar{R}$  has proven to give absolute maximum for  $\phi \approx 2$  and  $s = 0.5$ . This means that to reduce the cheater population keeping a wealthy society requires spending a non-realistic part of the yearly budget. Unfortunately, this can not be attainable in any society. Another alternative is to minimize the distance to an "ideal point" where both,  $\bar{w}$  and  $1 - \bar{y}$ , reach their largest value ( $(1 - \bar{y}, \bar{w}) = (1, 16)$ , for the parameter setup used in section 4). As a preliminary step, we have defined a weighted Euclidean distance (23) that exhibits an absolute minimum for approximate values  $s = 0.9$  and  $\phi = 0.05$ . These values are quite insensitive to variations in the normalization parameter  $\lambda$ . Finally, it is also suggested the possibility of optimizing  $\bar{w}$  and handle with the corresponding cheater density. Fortunately, as stated in section 4, for the couple  $(0.05, 0.9)$  that maximizes  $\bar{w}$ , the cheater population is drastically dropped to 1 percent of the population. In any case, we think that the essential matter here is that decision makers have to their disposal a kind of models to complement the empirical data they tackle. By considering several compromise functions that weight differently each aspect of the problem, authorities possess more elements to get the right choice. A deeper comparison of the results obtained from different compromise functions is left then as a future work.

This result is not independent of the values of the rest of the parameters of the model. In fact, the model is particularly sensitive to changes in  $k$ , the parameter that measures the efficiency of police actions. Obviously, if the efficiency of policing is much larger than that of

social promotion, it would be beneficial to spend most of the money to enhance this strategy. On the contrary, if the efficiency of guards is very low, then money is always better spent in education and other social activities. A detailed study of the dependence of the level of criminality and the total wealth has been carried out in section 4. As expected, a sharp and striking variation in these values occurs for a critical  $k$ -value.

Despite neglecting all stochastic factors, population models, that basically describe average dynamics, offer a useful approximation to the study of this kind of systems. Obviously, they are not able to predict neither individual behaviours nor explain emergent behaviours from basic rules. Thus, this deterministic models must be complemented with other techniques that include a probabilistic formulation. Specially fruitful are the so called cellular automata models where local rules of evolution are considered. We are currently applying this kind of approach to incorporate the spatial dimension to this model. Indeed, it is interesting to study the effect of having different strategies on both how much ( $\phi$ ) and how ( $s$ ) in different societies that coexist in a given area. In the discrete case, agents can be in two states: contributing or not to the total wealth. The probability of changing from one state to another depends on both local rules (how many neighbors belong to each state) and global ones, according to the total wealth of the system (for instance, wealth could foster to become a tax-payer). In addition to the own dynamics of this model, it would be relevant to investigate the appearance of dynamical boundaries among regions with different politics, as well as how the obtained patterns depend on  $\phi$  and  $s$ .

## 6.1 Acknowledgments

This work has been partially supported by Italy-Spain Integrated Action HI2006-0026 as well as by project ?? of the Spanish Ministerio de Educacin y Ciencia.

## References

- [1] (MR2034494) R. Azevedo Araujo & T.B. S. Moreira *A dynamic model of production and traffic of drugs*, Economic Letters **82**, (2004) 371-376.
- [2] Ball, P. (2004). The physical modelling of human social systems, ComPlexUs. 1, 190-206.

- [3] M. Campbell and P. Ormerod (2004) Social interactions and the dynamics of crime. <http://www.volterra.co.uk/publications/04/crime.pdf>
- [4] J. P. Carpenter (2007) The demand for punishment. *Journal of Economic Behavior & Organization*, 62, 4, 522-542
- [5] Fehr, E. and S. Gächter (2000) Cooperation and Punishment in Public Goods Experiments. *American Economic Review*, Vol. 90, No. 4 980-994
- [6] Feichtinger, G., C.V. Forst and C. Piccardi (1996) A nonlinear dynamical model for the dynastic cycle. *Chaos, solitons and fractals*, 7, 257-271
- [7] Brandt, H., C. Hauert and K. Sigmund (2006) Punishing and abstaining for public goods. *PNAS*, 103, 495-497
- [8] Henrich, J. *et al.* (2006) Costly punishment across human societies. *Science*, 312, 1767-1770
- [9] Hirsch . M. W. and S. Smale (1974) *Differential equations, Dynamical systems and linear algebra*. Academic press (1974)
- [10] C. Lewis (ed.) "Modelling crime and offending: recent developments in England and Wales". Occasional paper no. 80, 2003.
- [11] Johnson, D., P. Stopka and S. Knights (2003) The puzzle of human cooperation (Brief communications) *Nature*, 421, 911-912
- [12] R.M. May (2001) *Stability and complexity in model ecosystems*. Princeton University Press.
- [13] Meacci, L. and J.C. Nuño (2009) Spatially distributed W-models. In preparation.
- [14] Nuño, J.C., M.A. Herrero and M. Primicerio (2008) A triangle model of criminality. *Physica A*, 387, 2926-2936
- [15] Nuño, J.C., M.A. Herrero and M. Primicerio (2009) A mathematical model of a criminal-prone society. *Discrete and Continuous Dynamical Systems-S*. In the press.
- [16] Ormerod, P., C. Mounfield and L. Smith (2001). *Non-linear modelling of burglary and violent crime in the UK*. Volterra Consulting Ltd.

- [17] Reed W.J. (2001) The Pareto, Zipf and other power law. *Economics letters*, 74, 15-19
- [18] S. Pierazzini and J.C. Nuño. (2008) Mathematica demonstration. <http://demonstrations.wolfram.com/ATriangleModelOfCriminality/>
- [19] Smith, D.A. (1977) Human population growth: stability or explosion? *Mathematics magazine*, **50**, 186-197
- [20] L.G. Vargo (1966) A note on crime control. *Bull.Math.Biophys.* **28**, 375-378
- [21] Yu, P.L. (1973) A class of solutions for group decision problems. *Management Science*, 19, 936-946
- [22] Zeleny, M. (1974) A concept of compromise solutions and the method of the displaced ideal. *Computers and operations research*, 1, 479-496
- [23] H. Zhao, F. Zhilan & C. Castillo-Chavez. The dynamics of poverty and crime, MTBI-02-08M, (2002)

## 7 Appendices

### 7.1 Appendix 1.

Social mobility in the absence of criminal (cheaters) was analyzed in section 3. Even when both social promotion and relegation depend on the total wealth, system (4) present at least one equilibrium point. This can be proved straightforwardly noticing that each  $\bar{X}_k$  can be expressed, for example, in terms of  $\bar{X}_1$ , i.e

$$\bar{X}_k = \frac{\alpha_1}{\beta_2} \frac{\alpha_2}{\beta_3} \dots \frac{\alpha_{k-1}}{\beta_k} \bar{X}_1 \equiv \gamma_{k-1}(\bar{W}) \bar{X}_1 \quad (24)$$

for all  $k = 2, \dots, n$ . Equation 2 can be now written in terms of  $X_1$ :

$$\bar{W} = c_1 \bar{X}_1 + \sum_{k=2}^n c_k \gamma_{k-1}(\bar{W}) \bar{X}_1 \quad (25)$$

This allows to express  $\bar{X}_1$  as an explicit function of  $\bar{W}$ :

$$\bar{X}_1 = \frac{\bar{W}}{c_1 + \sum_{k=1}^n c_k \gamma_{k-1}(\bar{W})} \quad (26)$$

Now, using the constant population constraint (5) we get:

$$N = \frac{\bar{W}}{c_1 + \sum_{i=2}^n c_i \gamma_{i-1}(\bar{W})} + \sum_{k=2}^n \gamma_{k-1}(\bar{W}) \frac{\bar{W}}{c_1 + \sum_{i=2}^n c_i \gamma_{i-1}(\bar{W})} \quad (27)$$

whence:

$$\bar{W} = N \frac{c_1 + \sum_{i=2}^n c_i \gamma_{i-1}(\bar{W})}{1 + \sum_{i=2}^n \gamma_{i-1}(\bar{W})} \quad (28)$$

To see that this equation always admits at least one solution, let us define the auxiliary function:

$$G(\bar{W}) = \bar{W} - N \frac{c_1 + \sum_{i=2}^n c_i \gamma_{i-1}(\bar{W})}{1 + \sum_{i=2}^n \gamma_{i-1}(\bar{W})} \quad (29)$$

$G$  is continuous in  $[0, c_n N]$  and satisfies that

$$G(0) < 0; \quad G(c_n N) > 0 \quad (30)$$

Therefore, the equation  $G = 0$  has at least one solution  $\bar{W} \in (0, N c_n)$ .

## 7.2 Appendix 2

The main qualitative features of the model described in section 3 are already found in a simpler situation when the social structure of the society is not taken into account. What we want to outline is that, although the model is now simpler, we can derive from its analysis some general characteristics that are found also in the much richer system (20).

Let us assume then that the contributor population is  $X$  and  $Y$  is the cheater population. As before, we assume that the total population is kept constant, i.e.  $X + Y = N$ . The contribution of law-abiding citizens gives rise to a common wealth  $W$ , that is used to keep the society working and to convince cheaters to pay taxes. So, the time evolution of the total wealth is then given by:

$$\dot{W} = a(N - Y) - \theta W - \phi W \quad (31)$$

Here  $a$  is the contribution of the law-abiding population  $X = N - Y$  and  $\theta$  is the rate of expenditure that is required to maintain the society.  $\phi$  measures the extra cost that is devoted to fight cheaters.

The time evolution of the cheater population is given by

$$\dot{Y} = \tau(W)(N - Y) - \gamma(W)Y \quad (32)$$

where  $\tau$  is the rate of recruitment of cheater from the normal population and  $\alpha$  is the rate of transformation into law-abiding citizens. As in the 2-D model, how the extra expenditure is devoted to each of the measures is regulated by the authorities by tuning the parameter  $s$ . In particular, we put  $\tau_0 = 0$  in [?] and

$$\tau_1 = \frac{\bar{\tau}_1}{1 + \eta_1 s \phi W} \quad (33)$$

whereas  $\gamma$  depends linearly of  $W$ :

$$\gamma = \mu + k(1 - s) \phi W \quad (34)$$

With these definitions the dynamical system that describes completely the system behaviour is:

$$\begin{aligned} \dot{Y} &= \frac{\bar{\tau}_1}{1 + \eta_1 s \phi W} (N - Y) - (\mu + k(1 - s) \phi W) Y \\ \dot{W} &= a(N - Y) - \theta W - \phi W \end{aligned} \quad (35)$$

Next, we normalize  $y = \frac{Y}{N}$  and  $w = \frac{W}{aN}$ . Therefore,

$$\begin{aligned} \dot{y} &= \frac{\bar{\tau}_1}{1 + \eta_1 s \phi W} (1 - y) - (\mu + k(1 - s) \phi w) y \\ \dot{w} &= (1 - y) - (\theta + \phi) w \end{aligned} \quad (36)$$

where the system parameters have been redefined:  $\eta_1 = \eta_1 a N$  and  $k = k N a$  (for simplicity we keep to the same notation).

Contrary to the 2-classes W-model, system (36) can be studied qualitatively using bidimensional techniques. In particular, analyzing the isoclines we can proof the existence of a unique equilibrium point (see figure 9). The horizontal (null slope) isocline is given by:

$$w = \frac{1 - y}{\theta + \phi} \quad (37)$$

The vertical (infinite slope) isocline is implicitly defined by the equation

$$\bar{\tau}_1 (1 - y) - (1 + \eta_1 s \phi w)(\alpha_0 + \alpha_1 (1 - s) \phi w) y = 0 \quad (38)$$

An equivalent parameter setup to that chosen in section 3 is the following  $\mu = 0.01$ ,  $k = 1$ ,  $\bar{\tau}_1 = 0.01$ ,  $\eta_1 = 100$  and  $\theta = 1$ . It can be easily seen that both isoclines cross only once inasmuch for  $w = 0$   $h$ -isocline is over  $v$ -isocline, whereas the contrary occurs for  $y = 0$  where  $h$ -isocline is below the  $v$ -isocline. Besides, the first derivative of  $w$  with respect to  $y$  in (38) is always negative irrespectively of the parameters values, whereas the second derivative is always



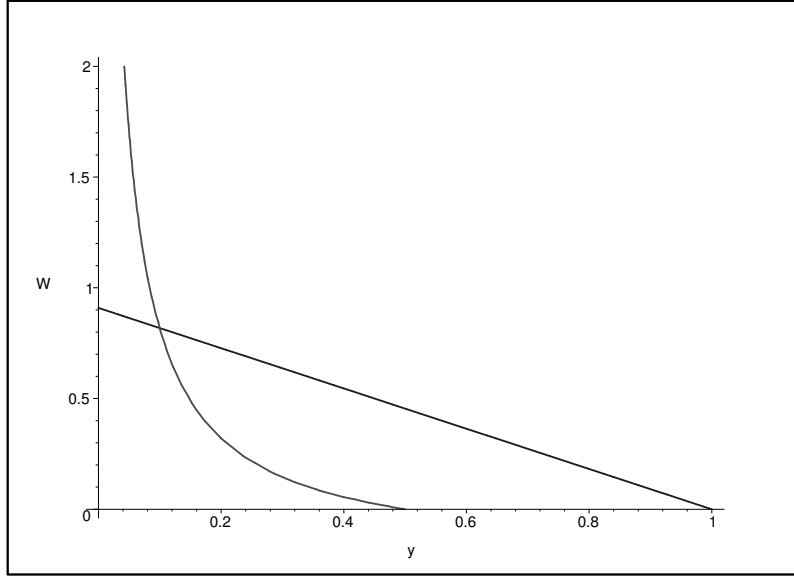

Figure 9: Null and infinity isoclines. The parameter setup is the following:  $\mu = 0.01$ ,  $k = 1$ ,  $\bar{\tau}_1 = 0.01$ ,  $\eta_1 = 100$  and  $\theta = 1$ .

positive. Then, for this case, the equilibrium point of (36) exists and is unique. In addition, this equilibrium point is always asymptotically stable.

Figure 10 depicts the tridimensional plots of both the stationary cheater population and the corresponding total wealth as a function of  $\phi$  (how much) and  $s$  (how). As can be seen, whereas the cheater population decreases monotonically as  $\phi$  increases for all  $s \in [0, 1]$ , the total wealth presents a peak for a given value of  $\phi$  that is a function of  $s$ . As we did in section 4, auxiliary objective functions could be defined to find a couple  $(\phi, s)$  that optimizes the strategy to fight cheaters. A deeper analysis of this kind of 2-D system is been currently performed [13].

### 7.3 Appendix 3

This appendix gives an idea of the kind of algebraic equations must be solved to obtain the equilibrium points of system (20). For the particular parameter setup, the stationary cheater population is the unique solution of the fourth degree algebraic equation:

$$\begin{aligned}
& 256 \cdot 10^5 \phi^2 s (s - 1) \bar{y}^4 + (40296000 s \phi^2 - 40800 \phi - 43240000 \phi^2 s^2 + 56000 \phi s + 2959600 \phi^2 - 400) \bar{y}^3 + \\
& +(29040 \phi - 12121400 s \phi^2 + 15080000 \phi^2 s^2 - 41400 \phi s + 270 - 2971230 \phi^2) \bar{y}^2 + \\
& + (-2565600 s \phi^2 + 2560000 \phi^2 s^2 + 4071 \phi^2 + 71 - 5600 \phi s + 4142 \phi) \bar{y} + 4 + 4 \phi^2 + 8 \phi = 0
\end{aligned} \tag{39}$$

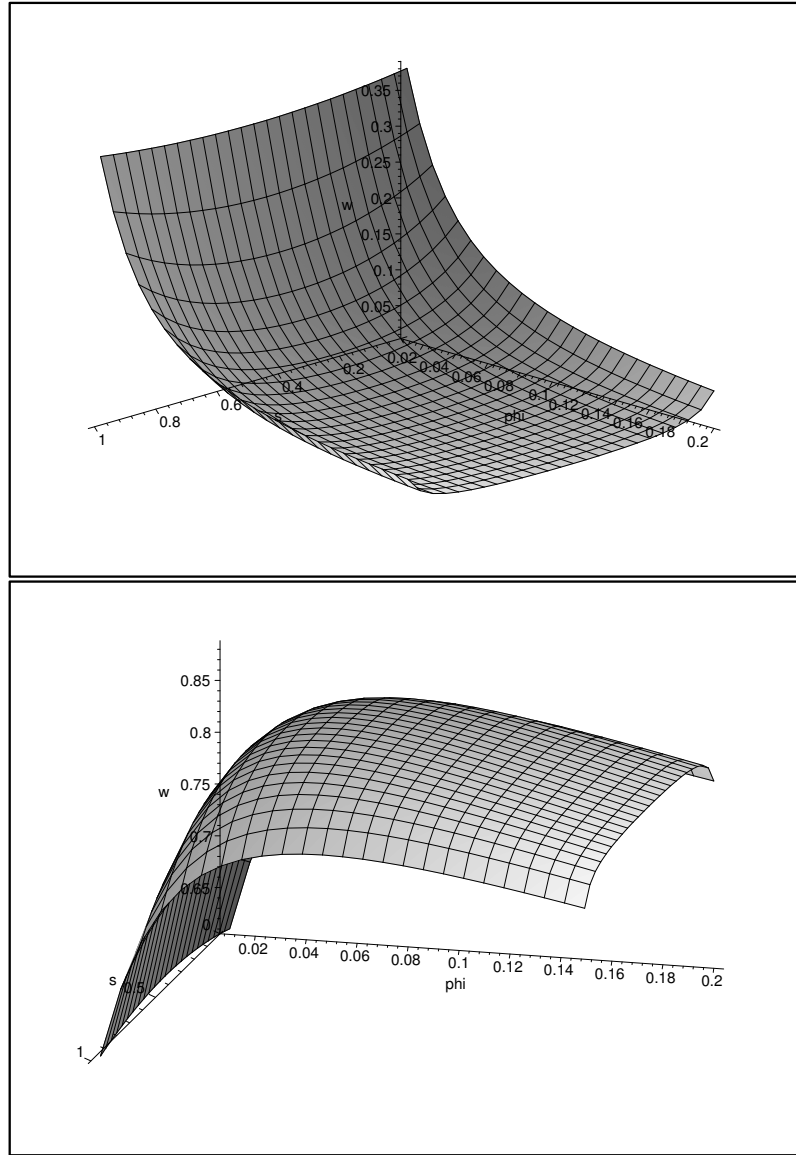

Figure 10: Cheater population and the corresponding total wealth for the 1 class model as a function of  $\phi$  and  $s$ . The parameter setup is as in figure 9

The corresponding stationary total wealth of the society is then the solution of the quadratic equation:

$$20 \phi s (1 + \phi) \bar{w}^2 + (320 \phi s(1 - \bar{y}) + 1 + \phi) \bar{w} - 4 + 4 \bar{y} = 0 \quad (40)$$