



UNIVERSITÀ  
DEGLI STUDI  
FIRENZE

# FLORE

## Repository istituzionale dell'Università degli Studi di Firenze

### **Wireless Sensor Networks for On-Field Agricultural Management Process**

Questa è la Versione finale referata (Post print/Accepted manuscript) della seguente pubblicazione:

*Original Citation:*

Wireless Sensor Networks for On-Field Agricultural Management Process / L. Bencini; D. Di Palma; G. Collodi; A. Manes; G. Manes. - STAMPA. - (2010), pp. 1-18.

*Availability:*

This version is available at: 2158/402789 since: 2021-03-19T01:46:46Z

*Publisher:*

InTech Open Access Publisher

*Terms of use:*

Open Access

La pubblicazione è resa disponibile sotto le norme e i termini della licenza di deposito, secondo quanto stabilito dalla Policy per l'accesso aperto dell'Università degli Studi di Firenze (<https://www.sba.unifi.it/upload/policy-oa-2016-1.pdf>)

*Publisher copyright claim:*

(Article begins on next page)

# Wireless Sensor Networks for On-field Agricultural Management Process

Luca Bencini, Davide Di Palma, Giovanni Collodi and Gianfranco Manes  
*Department of Electronics and Telecommunications - University of Florence*  
*Italy*

Antonio Manes  
*Netsens S.r.l.*  
*Italy*

## 1. Introduction

Agriculture is one of the most ancient activities of man in which innovation and technology are usually accepted with difficulty, unless real and immediate solutions are found for specific problems or for improving production and quality. Nevertheless, a new approach of gathering information from the environment could represent an important step towards high quality and eco-sustainable agriculture.

Nowadays, irrigation, fertilization and pesticides management are often left to the farmer's and agronomist's discretion: common criteria used to guarantee safe culture and plant growth are often giving a greater amount of chemicals and water than necessary. There is no direct feedback between the decision of treating or irrigating plants and the real effects in the field. Plant conditions are usually committed to sporadic and faraway weather stations that cannot provide accurate and local measurements of the fundamental parameters in each zone of the field. Also, agronomic models, based on these monitored data, cannot provide reliable information. On the contrary, agriculture needs detailed monitoring in order to obtain real time feedback between plants, local climate conditions and man's decisions.

The concept of precision agriculture has been around for some time now. Blackmore et al., in 1994 (Blackmore, 1994) defined it as a comprehensive system designed to optimize agricultural production by carefully tailoring soil and crop management to correspond to the unique condition found in each field while maintaining environmental quality. The early adopters during that time found precision agriculture to be unprofitable and the instances in which it was implemented were few and far between. Further, the high initial investment in the form of electronic equipment for sensing and communication meant that only large farms could afford it. The technologies proposed at this point comprised three aspects: *Remote Sensing* (RS), *Global Positioning System* (GPS) and *Geographical Information System* (GIS). RS coupled with GPS coordinates produced accurate maps and models of the agricultural fields. The sampling was typically through electronic sensors such as soil probes and remote optical scanners from satellites. The collection of such data in the form of electronic computer databases gave birth to the GIS. Statistical analyses were then conducted on the data and the variability of agricultural land was charted with respect to its properties. The technology, apart from being

non-real-time, involved the use of expensive technologies like satellite sensing and was labor intensive where the maps charting the agricultural fields were mostly manually done.

Over the last seven years, the advancement in sensing and communication technologies has significantly brought down the cost of deployment and running of a feasible precision agriculture framework. Emerging wireless technologies with low power needs and low data rate capabilities have been developed which perfectly suit precision agriculture (Wang et al., 2006). The sensing and communication can now be done on a real-time basis leading to better response times. The wireless sensors are cheap enough for wide spread deployment and offer robust communication through redundant propagation paths (Akyildiz & Xudong, 2005). Thanks to these features, the *Wireless Sensor Networks* (WSNs) (Akyildiz & Xudong, 2005) have become the most suitable technology to fit an invasive method of monitoring the agricultural environment.

In this chapter, an end-to-end monitoring WSN technology-based solution is presented, joining hardware optimization with communications protocols design and a suitable interface. In particular Section 2 discusses the system requirements and illustrates the overall system characterization in conjunction with related work. Sections 3, 4 and 5 deal respectively with the system in terms of hardware, protocol and software design. Section 6 describes the actual experiences, focusing on several case study analyses for highlighting the effectiveness and accurateness of the developed system. Sections 7 and 8 describe respectively the commercial system "VineSense", born from the experimental solution, and some agronomic results. Finally, in Section 9 some conclusions are drawn in order to explain the future direction of the current research study.

## 2. System Requirement and Architecture

The requirements that adopting a WSN are expected to satisfy in effective agricultural monitoring concern both *system level* issues (i.e., unattended operation, maximum network life time, adaptability or even functionality and protocol self-reconfigurability) and *final user* needs (i.e., communication reliability and robustness, user friendliness, versatile and powerful graphical user interfaces). The most relevant mainly concerns the supply of *stand-alone* operations. To this end, the system must be able to run unattended for a long period, as nodes are expected to be deployed in zones that are difficult to maintain. This calls for optimal energy management ensuring that the energy spent is directly related to the amount of traffic handled and not to the overall working time. In fact, energy is nevertheless a limited resource and the failure of a node may compromise WSN connectivity as the network gets partitioned. Other issues to be addressed are the capabilities of quickly setting-up an end-to-end communication infrastructure, supporting both synchronous and asynchronous queries, and of dynamically reconfiguring it. An additional requirement is *robust* operative conditions, which need fault management since a node may fail for several reasons. Other important properties are *scalability* and *adaptability* of the network's topology, in terms of the number of nodes and their density in unexpected events with a higher degree of responsiveness and reconfigurability. This also implies the development of a *plug and play* sensor interface and the provisioning of remote connectivity. Finally, several user-oriented attributes, including *fairness*, *latency*, *throughput* and enhanced data querying schemes (i.e., *time-driven* (Al-Karaki & Kamal, 2004) or *query-driven*) need to be taken into account even if they could be considered secondary with respect to our application purposes because the WSN's cost/performance trade-off (Langendoen & Halkes, 2004).

A WSN system was developed according to the afore mentioned requirements. The system, shown in Fig. 1, comprises a self-organizing mesh WSN endowed with sensing capabilities, a GPRS Gateway, which gathers data and provides a TCP-IP based connection toward a Remote Server, and a Web Application, which manages information and makes the final user capable of monitoring and interacting with the instrumented environment.

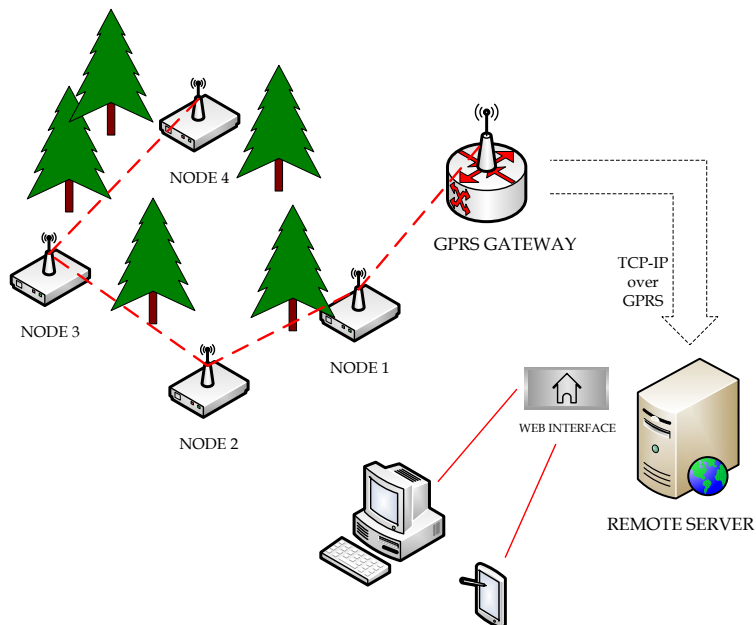

Fig. 1. Wireless Sensor Network System

### 3. Hardware Design

Focusing on an end-to-end system architecture, every constitutive element has to be selected according to application requirements and scenario issues, especially regarding the hardware platform. Many details have to be considered, involving the energetic consumption of the sensor readings, the power-on and power-save status management and a good trade-off between the maximum radio coverage and the transmitted power. After an accurate investigation of the out-of-the-shelf solutions, 868 MHz *Mica2 motes* (Mica2 Series, 2002) were adopted according to these constraints and to the reference scenarios. The *Tiny Operative System* (TinyOS) running on this platform ensures full control of mote communication capabilities to attain optimized power management and provides necessary system portability towards future hardware advancements or changes. Nevertheless, Mica2 motes are far from perfection, especially in the RF section, since the power provided by the transceiver (*Chipcon CC1000*) is not completely available for transmission. However, it is lost to imperfect coupling with the antenna, thus reducing the radio coverage area. An improvement of this section was performed, using more suitable antennas and coupling circuits and increasing the transmitting power with a power amplifier, thus increasing the output power up to 15 dBm while respecting international restrictions and standards. These optimizations allow for greater radio coverage (about

200 m) and better power management. In order to manage different kinds of sensors, a compliant sensor board was adopted, allowing up to 16 sensor plugs on the same node; this makes a single mote capable of sensing many environmental parameters at a time (Mattoli et al., 2005). Sensor boards recognize the sensors and send *Transducer Electronic Datasheets* (TEDS) through the network up to the server, making it possible for the system to recognize an automatic sensor. The overall node stack architecture is shown in Fig. 2.

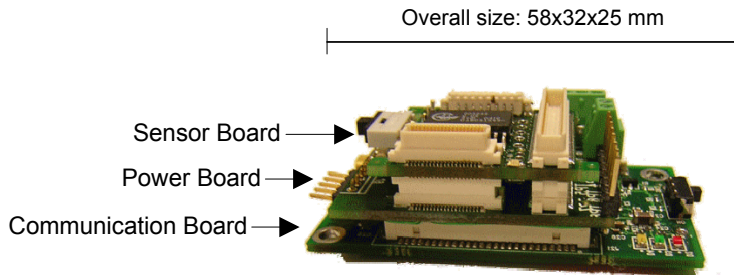

Fig. 2. Node Stack Architecture

The GPRS embedded Gateway, shown in Fig. 3, is a stand-alone communication platform designed to provide transparent, bi-directional wireless TCP-IP connectivity for remote monitoring. In conjunction with *Remote Data Acquisition* (RDA) equipment, such as WSN, it acts when connected with a Master node or when directly connected to sensors and transducers (i.e., Stand-Alone weather station, Stand-Alone monitoring camera).



Fig. 3. GPRS Gateway

The main hardware components that characterize the gateway are:

- a miniaturized GSM/GPRS modem, with embedded TCP/IP stack (Sveda et al., 2005), (Jain et al., 1990);
- a powerful 50 MHz clock microcontroller responsible for coordinating the bidirectional data exchange between the modem and the master node to handle communication with the Remote Server;

- an additional 128 KB SRAM memory added in order to allow for data buffering, even if the wide area link is lost;
- several A/D channels available for connecting additional analog sensors and a battery voltage monitor.

Since there is usually no access to a power supply infrastructure, the hardware design has also been oriented to implement low power operating modalities, using a 12 V rechargeable battery and a 20 W solar panel.

Data between the Gateway and Protocol Handler are carried out over TCP-IP communication and encapsulated in a custom protocol; from both local and remote interfaces it is also possible to access part of the Gateway's configuration settings. The low-level firmware implementation of communication protocol also focuses on facing wide area link failures. Since the gateway is always connected with the Remote Server, preliminary connectivity experiments demonstrated a number of possible inconveniences, most of them involving the *Service Provider Access Point Name* (APN) and *Gateway GPRS Support Node* (GGSN) subsystems. In order to deal with these drawbacks, custom procedures called *Dynamic Session Re-negotiation* (DSR) and *Forced Session Re-negotiation* (FSR), were implemented both on the gateway and on the CMS server. This led to a significant improvement in terms of disconnection periods and packet loss rates.

The DSR procedure consists in a periodical bi-directional control packet exchange, aimed at verifying the status of uplink and downlink channels on both sides (gateway and CMS). This approach makes facing potential deadlocks possible if there is asymmetric socket failure, which is when one device (acting as client or server) can correctly deliver data packets on the TCP/IP connection but is unable to receive any. Once this event occurs (it has been observed during long GPRS client connections, and is probably due to Service Provider Access Point failures), the DSR procedure makes the client unit to restart the TCP socket connection with the CMS.

Instead, the FSR procedure is operated on the server side when no data or service packets are received from a gateway unit and a fixed timeout elapses: in this case, the CMS closes the TCP socket with that unit and waits for a new reconnection. On the other side, the gateway unit should catch the close event exception and start a recovery procedure, after which a new connection is re-established. If the close event should not be signaled to the gateway (for example, the FSR procedure is started during an asymmetric socket failure), the gateway would anyway enter the DSR recovery procedure.

In any case, once the link is lost, the gateway unit tries to reconnect with the CMS until a connection is re-established.

#### 4. Protocol Design

The most relevant system requirements, which lead the design of an efficient Medium Access Control (MAC) and routing protocol for an environmental monitoring WSN, mainly concern power consumption issues and the possibility of a quick set-up and end-to-end communication infrastructure that supports both synchronous and asynchronous queries. The most relevant challenge is to make a system capable of running unattended for a long period, as nodes are expected to be deployed in zones that are difficult to maintain. This calls for optimal energy management since a limited resource and node failure may compromise WSN connectivity. Therefore, the MAC and the network layer must be perfected ensuring that the energy used is directly related to the amount of handled traffic and not to the overall working time.

Other important properties are scalability and adaptability of network topology, in terms of number of nodes and their density. As a matter of fact, some nodes may either be turned off or may join the network afterward.

Taking these requirements into account, a MAC protocol and a routing protocol were implemented.

#### 4.1 MAC Layer Protocol

Taking the IEEE 802.11 Distributed Coordination Function (DCF) (IEEE St. 802.11, 1999) as a starting point, several more energy efficient techniques have been proposed in literature to avoid excessive power waste due to so called idle listening. They are based on periodical preamble sampling performed at the receiver side in order to leave a low power state and receive the incoming messages, as in the WiseMAC protocol (El-Hoiydi et al., 2003). Deriving from the classical contention-based scheme, several protocols (S-MAC (Ye et al., 2002), TMAC (Dam & Langendoen, 2003) and DMAC (Lu et al., 2004)) have been proposed to address the overhead idle listening by synchronizing the nodes and implementing a duty cycle within each slot.

Resorting to the above considerations, a class of MAC protocols was derived, named *Synchronous Transmission Asynchronous Reception* (STAR) which is particularly suited for a flat network topology and benefits from both WiseMAC and S-MAC schemes. More specifically, due to the introduction of a duty-cycle, it joins the power saving capability together with the advantages provided by the offset scheduling, without excessive overhead signaling. According to the STAR MAC protocol, each node might be either in an idle mode, in which it remains for a time interval  $T_l$  (*listening time*), or in an energy saving sleeping state for a  $T_s$  (*sleeping time*). The transitions between states are synchronous with a period frame equal to  $T_f = T_l + T_s$  partitioned in two sub-intervals; as a consequence, a duty-cycle function can also be introduced:

$$d = \frac{T_l}{T_l + T_s} \quad (1)$$

To provide the network with full communication capabilities, all the nodes need to be *weakly synchronized*, meaning that they are aware at least of the awaking time of all their neighbors. To this end, as Fig. 4 shows, a node sends a *synchronization message* (SYNC) frame by frame to each of its neighbor nodes known to be in the listening mode (Synchronous Transmission), whereas, during the set-up phase in which each node discovers the network topology, the control messages are asynchronously broadcasted. On the other hand, its neighbors periodically awake and enter the listening state independently (Asynchronous Reception). The header of the synchronization message contains the following fields: a unique node identifier, the message sequence number and the *phase*, or the time interval after which the sender claims to be in the listening status waiting for both synchronization and data messages from its neighbors. If the node is in the sleeping status, the phase  $\phi$  is evaluated according to the following rule:

$$\phi_1 = \tau - T_l \quad (2)$$

where  $\tau$  is the time remaining to the next frame beginning. Conversely, if the mote is in the listening status,  $\phi$  is computed as:

$$\phi_2 = \tau + T_s \quad (3)$$

In order to fully characterize the STAR MAC approach, the related energy cost normalized can be evaluated as it follows:

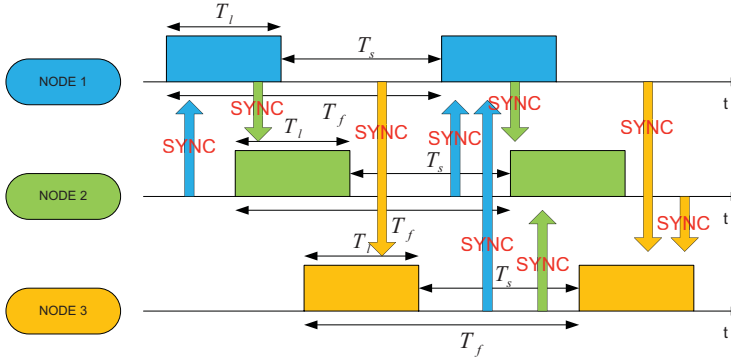

Fig. 4. STAR MAC Protocol Synchronization Messages Exchange

$$C = c_{rx}dT_f + c_{sleep}[T_f(1-d) - NT_{pkt}] + NC_{tx} \quad [mAh] \quad (4)$$

where  $c_{sleep}$  and  $c_{rx}$  represent the sleeping and the receiving costs [ $mA$ ] and  $C_{tx}$  is the single packet transmission costs [ $mAh$ ],  $T_f$  is the frame interval [ $s$ ],  $d$  is the duty cycle,  $T_{pkt}$  is the synchronization packet time length [ $s$ ] and finally  $N$  is the number of neighbors. When the following inequality is hold:

$$NT_{pkt} \ll T_f \quad (5)$$

then:

$$C \simeq c_{rx}dT_f + c_{sleep}T_f(1-d) + NC_{tx} \quad [mAh] \quad (6)$$

The protocol cost normalized to the synchronization time is finally:

$$\frac{C}{T_f} = c_{rx}d + c_{sleep}(1-d) + \frac{NC_{tx}}{T_f} \quad [mA] \quad (7)$$

As highlighted in Table 1, it usually happens that  $c_{tx} \ll c_{sleep} \ll c_{rx}$ , where  $c_{tx} = C_{tx}/T_{pkt}$  and  $T_{pkt}$  is the packet transmission time [ $s$ ] assumed equal to 100  $ms$  as worst case. This means that the major contribution to the overall cost is represented by the listening period that the STAR MAC protocol tries to suitably minimize.

$c_{rx}$	12	$mA$
$c_{sleep}$	0.01	$mA$
$C_{tx}$	30	$mAh$
$c_{tx}$	0.001	$mA$

Table 1. Power Consumption Parameters for the Considered Platform.

In Fig. 5(a) the normalized cost versus the number of neighbor nodes is shown for the S-MAC and STAR MAC schemes. It is worth noticing that the performance of the proposed protocol is better with respect to the existing approach for a number of neighbor nodes greater than 7. In Fig. 5(b) the normalized costs of S-MAC and STAR MAC approaches are compared with



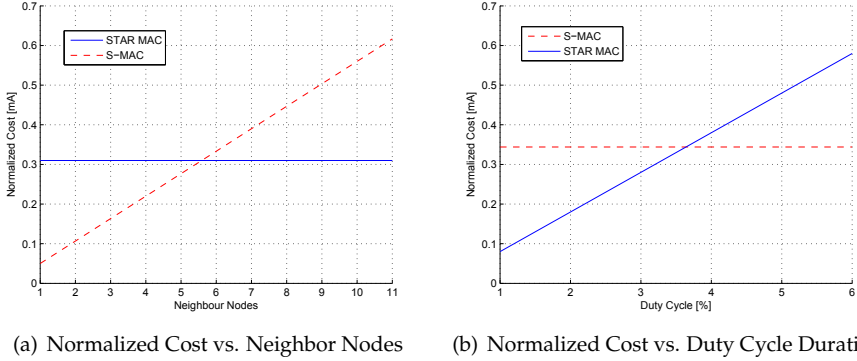

Fig. 5. STAR MAC Performance

respect to the duty cycle duration for a number of neighbor nodes equal to 8. It is possible to notice that for  $d < 3.5\%$  the proposed protocol provide a significant gain.

Nevertheless, for densely deployed or high traffic loaded WSN, STAR MAC approach might suffers the shortcoming of cost increasing due to the large number of unicasted messages. To limit this effect, an enhanced approach, named STAR+, was introduced, aiming at minimizing also the packet transmission cost. According to it, only one synchronization packet is multicasted to all the neighbor nodes belonging to a subset, i.e., such that they are jointly awake for a time interval greater than  $T_f$ . This leads to an additional advantage, as the number of neighbors increases allowing better performance with respect to scalability and a power saving too. Besides, the synchronization overhead is reduced with a consequent collisions lowering. Under this hypothesis the normalized cost might be expressed as:

$$\frac{C}{T_f} = c_{rx}d + c_{sleep}(1 - d) + \frac{KC_{tx}}{T_f} \quad [mA] \quad (8)$$

where  $K$  is the number of subsets. Since  $K \leq N$ , the normalized cost results to be remarkably lowered, especially if number of nodes and duty-cycle get higher, even if the latter case is inherently power consuming.

## 4.2 Network Layer Protocol

In order to evaluate the capability of the proposed MAC scheme in establishing effective end-to-end communications within a WSN, a routing protocol was introduced and integrated according to the *cross layer* design principle (Shakkottai et al., 2003). In particular, we refer to a proactive algorithm belonging to the class link-state protocol that enhance the capabilities of the *Link Estimation Parent Selection* (LEPS) protocol. It is based on periodically information needed for building and maintaining the local routing table, depicted in Table 2. However, our approach resorts both to the signaling introduced by the MAC layer (i.e., synchronization message) and by the Network layer (i.e., ping message), with the aim of minimizing the overhead and make the system more adaptive in a cross layer fashion. In particular, the parameters transmitted along a MAC synchronization message, with period  $T_f$ , are the following:

- *next hop* (NH) to reach the gateway, that is, the MAC address of the one hop neighbor;

- *distance* (HC) to the gateway in terms of number of needed hops;
- *phase* (PH) that is the schedule time at which the neighbor enter in listening mode according to Equation (2) and Equation (3);
- *link quality* (LQ) estimation as the ratio of correctly received and the expected synchronization messages from a certain neighbor.

Target	NH	HC	PH	LQ	BL	CL
Sink 1	A	$N_A$	$\phi_A$	$\eta_A$	$B_A$	$C_A$
	B	$N_B$	$\phi_B$	$\eta_B$	$B_B$	$C_B$
Sink 2	C	$N_C$	$\phi_C$	$\eta_C$	$B_C$	$C_C$
	D	$N_D$	$\phi_D$	$\eta_D$	$B_D$	$C_D$

Table 2. Routing Table General Structure

On the other hand, the parameters related to long-term phenomena are carried out by the ping messages, with period  $T_p \gg T_f$ , in order to avoid unnecessary control traffics and, thus, reducing congestion. Particularly, they are:

- *battery level* (BL) (i.e., an estimation of the energy available at that node);
- *congestion level* (CL) in terms of the ratio between the number of packets present in the local buffer and the maximum number of packets to be stored in.

Once, the routing table has been filled with these parameters, it is possible to derive the proper metric by means of a weighted summation of them. It is worth mentioning that the routing table might indicate more than one destination (*sink*) thanks to the ping messages that keep trace of the intermediate nodes within the message header.

## 5. Software and End User Interface Design

The software implementation was developed, considering a node as both a single element in charge of accomplishing prearranged tasks and as a part of a complex network in which each component plays a crucial role in the network's maintenance. As far as the former aspect is concerned, several TinyOS modules were implemented for managing high and low power states and for realizing a finite state machine, querying sensors at fixed intervals and achieving anti-blocking procedures, in order to avoid software failure or deadlocks and provide a robust stand alone system. On the other hand, the node has to interact with neighbors and provide adequate connectivity to carry the messages through the network, regardless of the destination. Consequently, additional modules were developed according to a cross layer approach that are in charge of managing STAR MAC and multihop protocols. Furthermore, other modules are responsible for handling and forwarding messages, coming from other nodes or from the gateway itself. Messages are not only sensing (i.e., measures, battery level) but also control and management messages (i.e., synchronization, node reset). As a result, a full interaction between the final user and the WSN is guaranteed.

The final user may check the system status through graphical user interface (GUI) accessible via web. After the log-in phase, the user can select the proper pilot site. For each site the deployed WSN together with the gateway is schematically represented through an interactive map. In addition to this, the related sensors display individual or aggregate time diagrams

for each node with an adjustable time interval (Start/Stop) for the observation. System monitoring could be performed both at a high level with a user friendly GUI and at a low level by means of message logging.

Fig. 6 shows some friendly Flash Player applications that, based on mathematical models, analyze the entire amount of data in a selectable period and provide ready-to-use information. Fig. 6(a) specifically shows the aggregate data models for three macro-parameters, such as vineyard water management, plant physiological activity and pest management. The application, using cross light colors for each parameter, points out normal (green), mild (yellow) or heavy (red) stress conditions and provides suggestions to the farmer on how to apply pesticides or water in a certain part of the vineyard. Fig. 6(b) shows a graphical representation of the soil moisture measurement. Soil moisture sensors positioned at different depths in the vineyard make it possible to verify whether a summer rain runs off on the soil surface or seeps into the earth and provokes beneficial effects on the plants: this can be appreciated with a rapid look at the soil moisture aggregate report which, shows the moisture sensors at two depths with the moisture differences colore in green tones. Fig. 6(c) highlights stress conditions on plants, due to dry soil and/or to hot weather thanks to the accurate trunk diametric growth sensor that can follow each minimal variation in the trunk giving important information on plant living activity. Finally, Fig. 6(d) shows a vineyard map: the green spots are wireless units, distributed in a vineyard of one hectare.

## 6. Real World Experiences

The WSN system described above was developed and deployed in three pilot sites and in a greenhouse. Since 2005, an amount of 198 sensors and 50 nodes have continuously sent data to a remote server. The collected data represents a unique database of information on grape growth useful for investigating the differences between cultivation procedures, environments and treatments.

### 6.1 Pilot Sites Description

The first pilot site was deployed in November 2005 on a sloped vineyard of the Montepaldi farm in Chianti Area (Tuscany - Italy). The vineyard is a wide area where 13 nodes (including the master node) with 24 sensors, running STAR MAC and dynamic routing protocols were successfully deployed. The deployment took place in two different steps: during the first one, 6 nodes (nodes 9,10,14,15,16,17) were placed to perform an exhaustive one week test. The most important result regards the multi-hop routing efficiency, estimated as:

$$\eta_{MHop} = \frac{M_{EU}}{M_{ex}} \quad (9)$$

where  $\eta_{MHop}$  is the efficiency,  $M_{EU}$  are the messages correctly received by the remote user and  $M_{ex}$  are the expected transmitted messages. For the gateway neighbors,  $\eta_{MHop}$  is very high, over 90%. However, even nodes far from the gateway (i.e., concerning an end-to-end multihop path) show a message delivery rate (MDR) of over 80%. This means that the implemented routing protocol does not affect communication reliability. After the second deployment, in which nodes 11,12,13,18,19,20 were arranged, the increased number of collisions changed the global efficiency, thus decreasing the messages that arrived to the end user, except for nodes 18,19,20, in which an upgraded firmware release was implemented. The related results are detailed in Table 3.

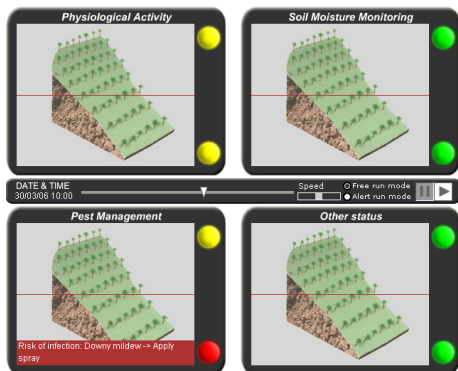

(a) Aggregate Data Models for Vineyard Water Management, Plant Physiological Activity and Pest Management

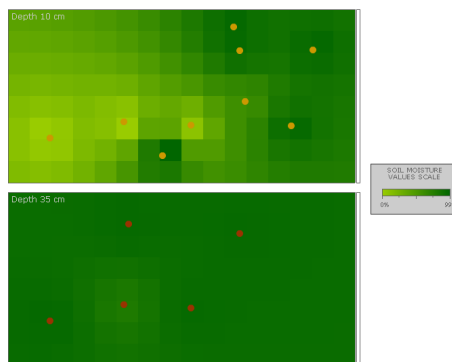

(b) Soil Moisture Aggregation Report: the upper map represent soil moisture @ 10 cm in the soil and the lower map represents soil moisture @ 35cm in the vineyard after a slipping rain



(c) Trunk Diametric Growth Diagram: daily and nightly metabolic phases



(d) Distributed Wireless Nodes in a Vineyard

Fig. 6. Flash Player User Interface

This confirms the robustness of the network installed and the reliability of the adopted communications solution, also considering the power consumption issues: batteries were replaced on March 11<sup>th</sup> 2006 in order to face the entire farming season. After that, eleven months passed before the first battery replacement occurred on February 11<sup>th</sup> 2007, confirming our expectations and fully matching the user requirements. The overall Montepaldi system has been running unattended for one year and a half and is going to be a permanent pilot site. So far, nearly 2 million samples from the Montepaldi vineyard have been collected and stored in the server at the University of Florence Information Services Centre (CSIAF), helping agronomist experts improve wine quality through deeper insight on physical phenomena (such as weather and soil) and the relationship with grape growth.

The second pilot site was deployed on a farm in the Chianti Classico with 10 nodes and 50 sensors at about 500 m above sea level on a stony hill area of 2.5 hectares. The environmental

Location	MDR
Node 9	72.2%
Node 10	73.7%
Node 11	88.5%
Node 12	71.4%
Node 13	60.4%
Node 14	57.2%
Node 15	45.6%
Node 16	45.4%
Node 17	92.1%
Node 18	87.5%
Node 19	84.1%

Table 3. Message Delivery Rate for the Montepaldi Farm Pilot Site

variations of the the “terroir” have been monitored since July 2007, producing one of the most appreciated wines in the world.

Finally, the third WSN was installed in Southern France in the vineyard of Peach Rouge at Gruissan. High sensor density was established to guarantee measurement redundancy and to provide a deeper knowledge of the phenomena variation in an experimental vineyard where micro-zonation has been applied and where water management experiments have been performed for studying plant reactions and grape quality.

## 6.2 Greenhouse

An additional deployment at the University of Florence Greenhouse was performed to let the agronomist experts conduct experiments even in seasons like Fall and Winter, where plants are quiescent, thus breaking free from the natural growth trend. This habitat also creates the opportunity to run several experiments on the test plants, in order to evaluate their responses under different stimuli using in situ sensors.

The greenhouse environmental features are completely different from those of the vineyard: as a matter of fact, the multipath propagation effects become relevant, due to the indoor scenario and the presence of a metal infrastructure. A highly dense node deployment, in terms of both nodes and sensors, might imply an increased network traffic load. Nevertheless, the same node firmware and hardware used in the vineyard are herein adopted; this leads to a resulting star topology as far as end-to-end communications are concerned.

Furthermore, 6 nodes have been in the greenhouse since June 2005, and 30 sensors have constantly monitored air temperature and humidity, plants soil moisture and temperature, differential leaf temperature and trunk diametric growth. The sensing period is equal to 10 minutes, less than the climate/plant parameter variations, providing redundant data storage. The WSN message delivery rate is extremely high: the efficiency is over 95%, showing that a low number of messages are lost.

## 7. VineSense

The fruitful experience of the three pilot sites was gathered by a new Italian company, Netsens, founded as a spinoff of the University of Florence. Netsens has designed a new monitoring

system called VineSense based on WSN technology and oriented towards market and user applications.

VineSense exalts the positive characteristics of the experimental system and overcomes the problems encountered in past experiences, thus achieving an important position in the wireless monitoring market.

The first important outcome of the experimental system, enhanced by VineSense is the idea of an end-to-end system. Sensors deployed in the field constantly monitor and send measurements to a remote server through the WSN. Data can be queried and analyzed by final users thanks to the professional and user-friendly VineSense web interface. Qualified mathematic models are applied to monitoring parameters and provide predictions on diseases and plant growth, increasing agronomists' knowledge and reducing costs while paving the road for new vineyard management.

VineSense improves many aspects of the experimental system, both in electronics and telecommunications.

The MAC and Routing protocol tested in the previous experimental system showed such important and significant results in terms of reliability that the same scheme was also adopted in the VineSense system and minimal changes were introduced: the routing protocol is lighter in terms of data exchange, building the route with different parameters, aimed at increasing the message success rate, such as master node distance and received signal strength.

A more secure data encryption was adopted in data messages to protect customers from malicious sniffing or to discourage possible competitors from decrypting network data.

Furthermore, a unique key-lock sequence was also implemented on each wireless node to prevent stealing, ensuring correct use with only genuine Netsens products and only in combination with its master node, which comes from the factory.

The new wireless nodes are smaller, more economical, more robust and suited for vineyard operations with machines and tractors. The electronics are more fault-tolerant, easier to install and more energy efficient: only a 2200 *mAh* lithium battery for 2-3 years of continuous running without human intervention. Radio coverage has been improved up to 350 *m* and nodes deployment can be easily performed by end users who can rely on a smart installation system with instantaneous radio coverage recognition. Some users have also experimented with larger area coverage, measuring a point-to-point communication of about 600 *m* in the line of sight.

Hypothetically, a VineSense system could be composed of up to 255 wireless nodes and more than 2500 sensors, considering a full sensor set per node, but since it is a commercial system these numbers are much more than necessary to cover farmers' needs.

Sensors used in the VineSense system are low-cost, state-of-the-art devices designed by Netsens for guaranteeing the best accuracy-reliability-price ratio. The choice of Netsens to develop custom and reliable sensors for the VineSense system is not only strategic from a marketing point of view, since it frees VineSense from any kind of external problems, such as external supplying, delays, greater costs and compliancy. It is also a consequence of the "System Vision", where VineSense is not only a wireless communication system product, but an entire system with no "black holes" inside so as to provide the customer with a complete system with better support.

The VineSense wireless-sensor unit is shown in Fig. 7(a).

Recovery strategies and communication capabilities of the stand-alone GPRS gateway have been improved: in fact, data received by wireless nodes are both forwarded in real-time to a remote server and temporarily stored on board in case of abrupt disconnections; moreover,

automatic reset and restart procedures avoid possible software deadlocks or GPRS network failures. Finally, a high-gain antenna guarantees good GPRS coverage almost everywhere. The GPRS gateway firmware has been implemented for remotely managing of the acquisition settings, relieving users of the necessity of field maintenance.

The GPRS gateway communication has been greatly improved introducing new different communication interfaces, such as Ethernet connection (RJ-45), USB data downloading and the possibility of driving an external Wi-Fi communication system for short-range transmissions.

Since the beginning of 2010, the "Always On" connection started to be fully used and it boosted the VineSense system, enlarging its possible field of application: a complete bidirectional communication was established between the GPRS unit in the field and the remote server at Netsens. The previous "one way" data flow, from the vineyard to the internet, was gone over by a new software release, able to send instantaneous messages from the VineSense web interface to the field: the monitoring system was changed into the monitoring and control system, sending automatic, scheduled or asynchronous commands to the gateway station or to nodes, i.e. to open or close irrigation systems or simply to download a firmware upgrade. In Fig. 7(b) the GPRS gateway with weather sensors is shown.



(a) VineSense Wireless Unit



(b) VineSense GPRS Gateway with Weather Sensors

Fig. 7. VineSense Hardware Elements

The web interface is the last part of VineSense's end-to-end: the great amount of data gathered by the sensors and stored in the database needs a smart analysis tool to become useful and usable. For this reason different tools are at the disposal of various kinds of users. On one hand, some innovative tools such as control panels for real time monitoring or 2D chromatic maps create a quick and easy approach to the interface. On the other hand, professional plots and data filtering options allow experts or agronomists to study them more closely.

## 8. Agronomic Results

The use of VineSense in different scenarios with different agronomic aims has brought a large amount of important results.

When VineSense is adopted to monitor soil moisture positive effects can be obtained for plants and saving water, thus optimizing irrigation schedules. Some examples of this application can be found in systems installed in the Egyptian desert where agriculture is successful only through wise irrigation management. In such a terroir, plants suffer continuous hydric stress during daylight due to high air temperature, low air humidity and hot sandy soils with a low water retention capacity. Water is essential for plant survival and growth, an irrigation delay can be fatal for the seasonal harvest therefore, a reliable monitoring system is necessary. The adoption of VineSense in this scenario immediately resulted in continuous monitoring of the irrigating system, providing an early warning whenever pump failure occurred. On the other hand, the possibility to measure soil moisture at different depths allows agronomists to decide on the right amount of water to provide plants; depending on different day temperatures and soil moisture, pipe schedules can be changed in order to reduce water waste and increase water available for plants.

An example of different pipe schedules is shown in Fig. 8.

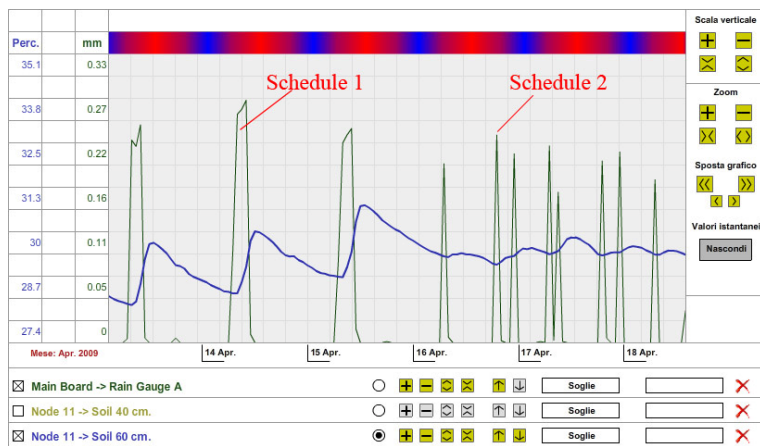

Fig. 8. Different Pipe Schedules in Accordance with Soil Moisture Levels

Originally, the irrigation system was opened once a day for 5 hours giving 20 liters per day (schedule 1); since sandy soils reach saturation very rapidly most of this water was wasted in deeper soil layers; afterwards irrigation schedules were changed (schedule 2), giving the same amount of water in two or more times per day; the water remained in upper soil layers at plant root level, reducing wastes and increasing the amount of available water for plants, as highlighted by soil moisture at 60 cm (blue plot).

Another important application of the VineSense system uses the dendrometer to monitor plant physiology. The trunk diametric sensor is a mechanical sensor with  $\pm 5$  microns of accuracy; such an accurate sensor can appreciate stem micro variations occurring during day and night, due to the xilematic flux inside the plant. Wireless nodes measure plant diameter every 15 minutes, an appropriate time interval for following these changes and for creating a plot showing this trend. In normal weather conditions, common physiologic activity can be recognized by agronomists the same as a doctor can do reading an electrocardiogram; when air temperature increases and air humidity falls in combining low soil moisture levels, plants change their activity in order to face water stress, preserve their grapes and especially them-



selves. This changed behavior can be registered by the dendrometer and plotted in the VineSense interface, warning agronomists about incoming risks; as a consequence, new irrigation schedules can be carried into effect.

Fig. 9 shows an example of a plant diametric trend versus air temperature.

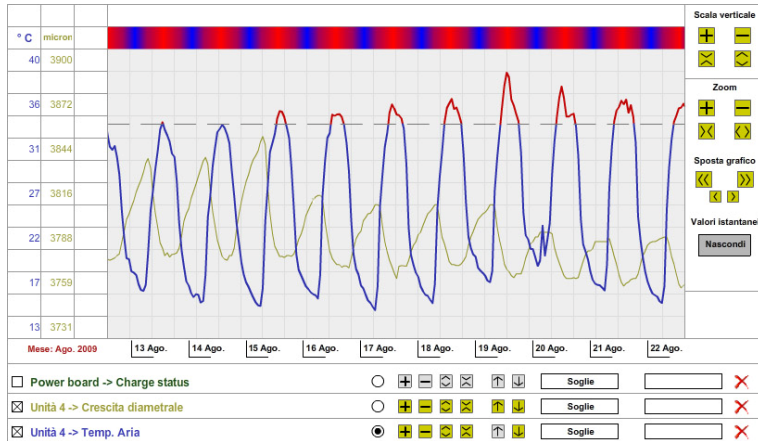

Fig. 9. Plant Diametric Trend vs. Air Temperature

The blue plot represents the air temperature in 10 days, from 13<sup>th</sup> August until the 22<sup>nd</sup> August 2009 in Italy; the blue line becomes red when the temperature goes over a 35 degree threshold. During the period in which the temperature is so high, plant stem variations are reduced due to the lower amount of xilematic flux flowing in its vessels, a symptom of water leakage.

WSN in agriculture are also useful for creating new databases with historical data: storing information highlighting peculiarities and differences of vineyards provides agronomists an important archive for better understanding variations in plant production capabilities and grape ripening. Deploying wireless nodes on plants in interesting areas increases the knowledge about a specific vineyard or a specific terroir, thus recording and proving the specificity of a certain wine. I.E., the quality of important wines such CRU, coming from only one specific vineyard, can be easily related to "grape history": data on air temperature and humidity, plant stress, irrigation and rain occurring during the farming season can assess a quality growing process, that can be declared to buyers.

Finally, VineSense can be used to reduce environmental impact thanks to a more optimized management of pesticides in order to reach a sustainable viticulture. Since many of the most virulent vine diseases can grow in wet leaf conditions, it is very important to monitor leaf wetness in a continuous and distributed way. Sensors deployed in different parts of vineyards are a key element for agronomists in monitoring risky conditions: since wetness can change very rapidly during the night in a vineyard and it is not homogeneous in a field, a real time distributed system is the right solution for identifying risky conditions and deciding when and where to apply chemical treatments. As a result, chemicals can be used only when they are strictly necessary and only in small parts of the vineyard where they are really needed, thus reducing the number of treatments per year and decreasing the amount of active substances sprayed in the field and in the environment. In some tests performed in 2009 in Chianti, the amount of pesticides was reduced by 65% compared to the 2008 season.

Leaf wetness sensors on nodes 2 and 3 measure different wetness conditions as shown in Fig. 10. The upper part of the vineyard is usually wetter (brown plot) than the lower part (blue plot) and sometimes leaf wetness persists for many hours, increasing the risk of attacks on plants.

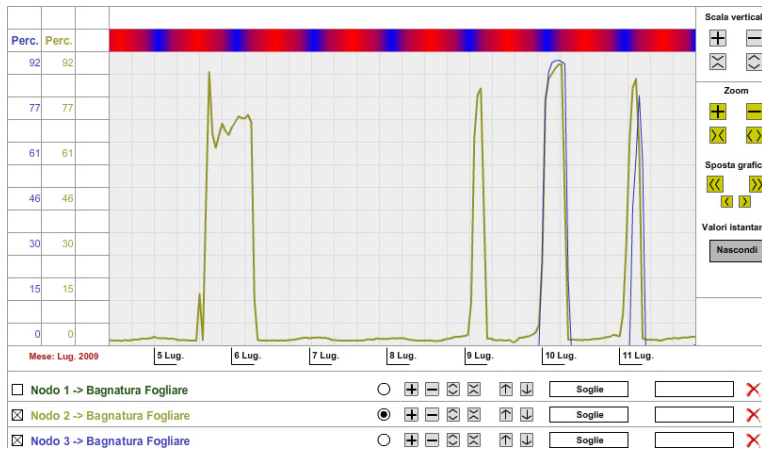

Fig. 10. Different Leaf Wetness Conditions in a Small Vineyard

## 9. Conclusion

This paper deals with the design, optimization and development of a practical solution for application to the agro-food chain monitoring and control. The overall system was addressed in terms of the experienced platform, network issues related both to communication protocols between nodes and gateway operations up to the suitable remote user interface. Every constitutive element of the system chain was described in detail in order to point out the features and the remarkable advantages in terms of complexity reduction and usability.

To highlight the effectiveness and accurateness of the developed system, several case studies were presented. Moreover, the encouraging and unprecedented results achieved by this approach and supported by several pilot sites into different vineyard in Italy and France were shown.

The fruitful experience of some pilot sites was gathered by a new Italian company, Netsens, founded as a spin off of the University of Florence. Netsens has designed a new monitoring system called VineSense based on WSN technology and oriented towards market and user applications. In order to point out the improvements of the new solution respect to the experimental one, the main features of VineSense were described. Moreover, some important agronomic results achieved by the use of VineSense in different scenarios were sketched out, thus emphasizing the positive effects of the WSN technology in the agricultural environment. Nowadays, the application of the solution described in this paper is under investigation to the more general field of environmental monitoring, due to its flexibility, scalability, adaptability and self-reconfigurability.

## 10. References

- Blackmore, S. (1994). Precision Farming: An Introduction, *Outlook on Agriculture Journal*, Vol. 23, pp. 275-280.
- Wang, N., Zhang, N. & Wang, M. (2006). Wireless sensors in agriculture and food industry - Recent development and future perspective, *Computers and Electronics in Agriculture Journal*, Vol. 50, pp. 114-120.
- Akyildiz, I.F. & Xudong, W. (2005). A Survey on Wireless Mesh Networks, *IEEE Communication Magazine*, Vol. 43, pp. S23-S30.
- Al-Karaki, J. & Kamal, A. (2004). Routing Techniques in Wireless Sensor Networks: a Survey, *IEEE Communication Magazine*, Vol. 11, pp. 6-28.
- Langendoen, K. & Halkes, G. (2004). Energy-Efficient Medium Access Control, *The Embedded Systems Handbook*, pp. 2-30.
- Mica2 Series, Available on <http://www.xbow.com>.
- Mattoli, V., Mondini, A., Razeed, K.M., O'Flynn, B., Murphy, F., Bellis, S., Collodi, G., Manes, A., Pennacchia, P., Mazzolai, B., & Dario, P. (2005). Development of a Programmable Sensor Interface for Wireless Network Nodes for Intelligent Agricultural Applications, *Proceedings of IE 2005*, IEEE Computer and Communications Societies, Sydney, pp. 1-6.
- Sveda, M., Benes, P., Vrba, R. & Zezulka, F. (2005). Introduction to Industrial Sensor Networking, *Handbook of Sensor Networks: Compact Wireless and Wired Sensing Systems*, pp. 10-24.
- Jain, J.N. & Agrawala, A.K. (1990). *Open Systems Interconnection: Its Architecture and Protocols*, Elsevier.
- IEEE Standard 802.11 (1999). *Wireless LAN Medium Access Control (MAC) and Physical Layer (PHY) Specifications*, IEEE Computer Society.
- El-Hoiydi, A., Decotignie, J., Enz, C. & Le Roux, E. (2003). WiseMAC, an Ultra Low Power MAC Protocol for the WiseNET Wireless Sensor Network, *Proceedings of SENSYS 2003*, Association for Computer Machinery, Los Angeles (CA), pp. 244-251.
- Ye, W., Heidemann, J. & Estrin, D. (2002). An Energy-Efficient MAC Protocol for Wireless Sensor Networks, *Proceedings of INFOCOM 2002*, IEEE Computer and Communications Societies, New York (NY), pp. 1567-1576.
- Dam, T. & Langendoen, K. (2003). An Adaptive Energy-Efficient MAC Protocol for Wireless Sensor Networks, *Proceedings of SENSYS 2003*, Association for Computer Machinery, Los Angeles (CA), pp. 171-180.
- Lu, G., Krishnamachari, B. & Raghavendra, C. (2004). Adaptive Energy-Efficient and Low-Latency MAC for Data Gathering in Sensor Networks, *Proceedings of WMAN 2004*, Institut fur Medien.Informatik, Ulm (Germany), pp. 2440-2443.
- Shakkottai, S., Rappaport, T. & Karlsson, P. (2003). Cross-Layer Design for Wireless Networks, *IEEE Communication Magazine*, Vol. 41, pp. 77-80.