



UNIVERSITÀ
DEGLI STUDI
FIRENZE

FLORE

Repository istituzionale dell'Università degli Studi di Firenze

Experimental evaluation of in-plane shear behaviour of masonry walls retrofitted using conventional and innovative methods

Questa è la Versione finale referata (Post print/Accepted manuscript) della seguente pubblicazione:

Original Citation:

Experimental evaluation of in-plane shear behaviour of masonry walls retrofitted using conventional and innovative methods / A. Borri; M. Corradi; A. Vignoli. - In: MASONRY INTERNATIONAL. - ISSN 0950-2289. - STAMPA. - 21:(2008), pp. 29-42.

Availability:

The webpage <https://hdl.handle.net/2158/434669> of the repository was last updated on

Terms of use:

Open Access

La pubblicazione è resa disponibile sotto le norme e i termini della licenza di deposito, secondo quanto stabilito dalla Policy per l'accesso aperto dell'Università degli Studi di Firenze (<https://www.sba.unifi.it/upload/policy-oa-2016-1.pdf>)

Publisher copyright claim:

La data sopra indicata si riferisce all'ultimo aggiornamento della scheda del Repository FloRe - The above-mentioned date refers to the last update of the record in the Institutional Repository FloRe

(Article begins on next page)



Masonry International

Journal of the British Masonry Society

www.masonry.org.uk

Spring 2008

FEATURED IN THIS ISSUE:

- Behaviour of a Historical Masonry Structure Subjected to Fire
- Analysis of Bond Performance between FRP Sheets and Calcarene Stones under Service and Ultimate Conditions
- Experimental Evaluation of In-plane Shear Behaviour of Masonry Walls Retrofitted Using Conventional and Innovative Methods
- Torsion Testing of Bed Joints

Experimental Evaluation of In-plane Shear Behaviour of Masonry Walls Retrofitted Using Conventional and Innovative Methods

by

M. CORRADI¹, A. BORRI* and A. VIGNOLI**

¹ Corresponding Author. Voice: +39 075 585 3906 Fax: +39 075 585 3897

Email: mcorradi@strutture.unipg.it

* Department of Civil and Environmental Engineering, School of Engineering, University of Perugia Via Duranti, 93 - 06125 Perugia, Italy

** Department of Civil and Environmental Engineering, School of Engineering, University of Florence, Via di S. Marta, 3 - 50139 Florence, Italy

ABSTRACT

This paper reports the results of a series of tests carried out on masonry panels in order to find the experimental values for masonry shear strength and stiffness. Twenty-five panels were assembled in the laboratory or cut from walls in-situ for a total number of sixty-three tests. The panels had been strengthened with either conventional and innovative materials and techniques. The strengthening techniques were applied as method of repair for damaged panels or as a method of preventive reinforcement. Concerning conventional methods, injections with new lime-based mixes, ferrocement and deep repointing of mortar joints panels injected, were used to strengthen unreinforced masonry. Other tests were made by gluing to the wall sheets of unidirectional fibre glass (GFRP) with an epoxy resin or GFRP grids with an hydraulic mortar. Another reinforcement technique involved retrofitting similar undamaged and damaged masonry panels with polypropylene nets. The purpose of the tests was to analyze the effectiveness of the intervention, above all as a technique of seismic-upgrading work. The results of the experiments carried out, in terms of lateral resistance and stiffness increases, although varying according to the retrofitting method applied, have highlighted their limitations as well as their advantages.

1. INTRODUCTION

In-plane resistance of unreinforced masonry (URM) walls is based on mortar strength and masonry unit proportions. If the horizontal forces are strong enough to exceed the in-plane strength capacity of the wall, a shear failure will occur. This failure mode is characterized by brittle tensile cracking through the mortar and the masonry unit.

Existing unreinforced masonry buildings made of brick and multi-leaf stone masonry walls, many of which have historical and cultural importance, constitute a significant portion of existing buildings in Italy and rest of the world. Recent earthquakes in Umbria (Italy) in 1997-1998 have shown the vulnerability of unreinforced masonry constructions due to masonry's almost total lack of tensile strength. This brought to light the urgent need to improve and develop better methods of retrofitting for existing seismically inadequate buildings. Several conventional techniques are available to improve the seismic performance of existing URM walls. Surface treatments, grout injections, external reinforcement are examples of such conventional techniques. Several researchers have discussed the disadvantages of these techniques: available space reduction, architectural impact, heavy mass, corrosion potential, etc. [1-4].

FRP (Fibre Reinforced Polymers) offer promising retrofitting possibilities for masonry buildings and present several well-known advantages over existing conventional techniques. Studies on shear retrofitting of unreinforced masonry using FRP are limited. A state-of-the-art of the FRP strengthening of civil engineering structures is presented in [5-10]. The main objective of the reinforcement is to enhance the earthquake resistance of masonry structural elements, in order to avoid failure modes that manifest in a brittle and unforeseen manner. Experimental studies concerning the in-plane behaviour were conducted by the same authors in 2002 [11-12], pursuing a comparative in site study of the effectiveness of different strengthening procedures applied to ancient stone masonry. In the same context, VALLUZZI et al. [13] performed an experimental study in order to investigate the efficiency of an FRP shear reinforcement technique.

In addition, since numerous parameters affect the behaviour of URM-FRP, the priority of the early experimental studies on this subject was to focus on the effectiveness of the technique rather than to quantify the effect of different parameters.

The aim of this work was to characterize the behaviour of the masonry typical of the areas struck by the seismic events of 1997-1998 and to study the effectiveness of seismic-upgrading methods both on un-damaged (preventive reinforcement) and damaged (repair) walls. The experimental work was carried out in situ and in the laboratory on masonry panels of various dimensions, sections and masonry textures which had been strengthened with either conventional or innovative materials and techniques. The results of some URM panels are reported with the only purpose to quantitatively evaluate the effectiveness of the interventions by means of comparison.

2. RETROFITTING METHODS APPLIED

The twenty-five panels were reinforced by five different methods: ferrocement, grout injections, joint repointing, FRP and polypropylene jacketing. A description of each retrofitting method and materials characterization of reinforcements are reported below.

2.1 Ferrocement

This method is applicable to most types of masonry walls and consists of applying reinforced cement or concrete coatings onto one or both faces of a wall. However, the application of a coating on both sides is strongly recommended. The reinforcing material can be steel rebars mesh or ferro-cement.

Strengthening by jacketing of rubble or cut, dimensioned stone masonry walls is an effective way to increase walls' shear resistance and lateral stiffness. Four masonry panels were reinforced with this method in order to compare the results with the other retrofitting methods applied to the same building and masonry wall. The concrete was applied by shotcreting and a total thickness of coating of 40-50mm was used (Figure 1). The coating was applied in two layers. After completing the first layer of shotcrete the steel (FeB 44K type) mesh (100 x 100mm, rebar diameter 6mm) was installed and then the second layer was applied. The steps for ferrocement reinforcement, applied to rubble or cut-stone masonry walls, were:

- removal of existing plaster;
- loose stones were first removed and then fixed with cement-based mortar.
- through holes are drilled for $\phi 6\text{mm}$ rebars anchors $9/\text{m}^2$ (Figure 2).

Six cubes (side length 150mm) were tested in compression. The 28-day average strength results were $22.55 \pm 2.75\text{N}/\text{mm}^2$.

2.2 Grout injections

The most common type of strengthening for in-plane resistance is the filling of the voids in the masonry. Grouting as a strengthening method can be effective for both existing and earthquake damaged stone masonry construction. Some types of stone masonry can be injected with grout although for well built stone walls this technique may not increase the wall's lateral resistance. The technique basically consists of filling the voids and/or cracks inside the wall by the injection of new mortar in order to restore its continuity. The injection therefore permits the homogenization of the masonry behaviour by saturating the cavities.

Stones and mortars were sampled from the walls and laboratory tests were carried out. Chemical, petrographic-mineralogical analyses were performed on the mortars in order to determine their composition: type of binder, type of aggregates, binder/aggregate ratio, aggregate size and dimensions. The mechanical characteristic values of these grouts, given by the producer, are shown in Table 1.

The morphology of the walls suggested that in some cases reinforcement by injection was not appropriate due to the fact that inside the masonry there was effectively loose

material and no voids were present. Therefore before applying the technique, appropriate tests were carried out in laboratory on sampled materials and also on site.

2.3 Joint repointing

A complementary technique to the grouting is the deep repointing of mortar joints with an appropriate mortar. Deep repointing is a repair and preventive technique for double leaf masonry walls carried out on the two faces of the masonry. These tests are described in detail in [14]. The aim of this repair is to bond the stones of the external leaves, particularly in the case of badly bonded irregular stones and to obtain an external confinement of the wall in order to increase the masonry shear strength. The repointing can be carried out also in conjunction with grout injection. The choice of the mortar to be used for repointing is also difficult; in fact, to have good durability, this mortar must be compatible with the existing masonry from the physical, chemical and mechanical points of view. In the case of deep repointing, the mortar should be strong enough but not too stiff, and have good bond with the stones and with the existing mortar (Table 2).

In fact, the aims of the deep repointing are the following: (i) to replace the damaged mortar on the wall surface to a depth of 70-80mm in order to adequately bond in-plane the stones, (ii) to confine the wall externally as a complement to injection, (iii) to provide a better penetration of the grout while avoiding leakage to the exterior. When the repointing is successful, 70+70mm of the wall section (in the case of two leaf walls the thickness varies from 400 to 550mm) are well bond together and constitute good confinement for vertical loads. This technique can ensure a uniform distribution of the material in the external leaves. Injection is not always successful if grout cannot penetrate inside the masonry and connect the two leaves; in many cases transversal connectors, are needed instead. Regardless of this, injection is necessary and effective when diffused cracks are present.

As will be described in a following section, deep repointing and injection were carried out on site on some masonry panels isolated from masonry walls of buildings damaged by the 1997 earthquakes in Umbria (Figure 3). The panels were subjected to mechanical tests before and after repair in order to determine the shear strength and the elastic and shear moduli; these tests also allowed the typical masonry of the region to be characterised.



Figure 1 Concrete jacketing applied to a masonry panel



Figure 2 Detail of connection between anchor bars and ferro-cement

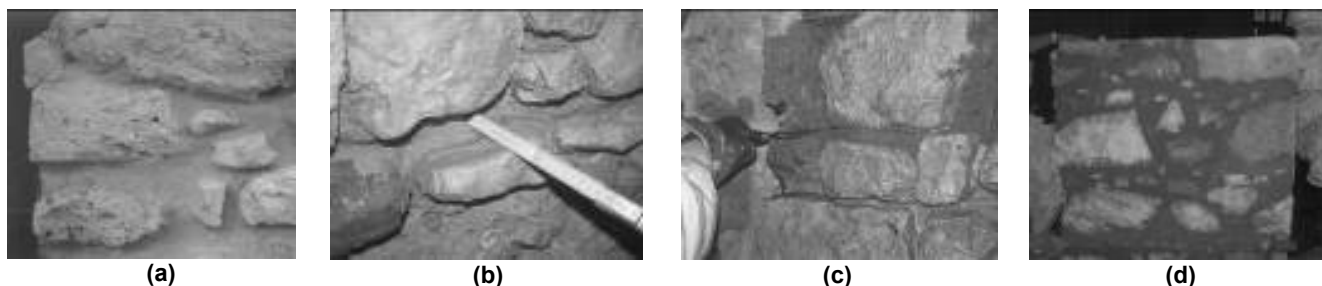

Figure 3 (a) Joint after cleaning; (b) detail of the joint depth; (c) first layer of repointing; (d) after intervention

**Table 1
Mechanical characteristics of mortar used for injections**

Components	Lime based hydraulic grout, kaolin calcined at low temperature, carbonates
Granulometry of the components (μm)	60
Compression strength (28 days) (N/mm^2)	8
Injection pressure (atm)	1
Built density (kg/dm^3)	1.75
$\text{H}_2\text{O}/\text{cement}$ weight ratio	0.45

**Table 2
Mechanical characteristics of mortar used for deep repointing**

Granulometry of the components [mm]	≤ 3
Compression strength (28-day) [N/mm^2]	7
Flexural strength (28-day) [N/mm^2]	3
Built density [Kg/dm^3]	1.85
Young modulus [N/mm^2]	8000

2.4 FRP jacketing

Retrofitting of existing structural members using FRP jacketing is a relatively new technique. Its efficiency is qualitatively demonstrated, but many aspects are not well assessed and thus difficult to quantify in practical applications.

Two types of FRP composites were employed: uni-directional glass fibre (noted FV) and glass FRP mesh (noted IG). The mechanical properties of the composites were determined in tension on coupons (Table 3).

The FRP laminates (FV type) involved in the experimental work consist in glass unidirectional fibres embedded in epoxy resin, according with the wet lay up technique. Strengthening with one sheet of GFRP was carried out on both sides of the panel, following the scheme presented in Figure 4.

The GFRP mesh (IG type) has a thickness of 0.67mm and has an opening of 10mm in longitudinal direction and 9mm in transversal direction (Figure 5). The main mechanical characteristics, declared by the manufacturer, are shown in Table 4. A coating made of hydraulic based mortar was used. The average compressive strength of the mortar was $3.3\text{N}/\text{mm}^2$. After the application was finished, each grid

reinforced coating was approximately 15-25mm thick (approx 15mm for brick panels and 25mm for stone panels).

For both uni-directional glass fibre and GFRP mesh reinforcement, through holes were drilled for $\phi 12\text{mm}$ GFRP rebars anchors at $5/\text{m}^2$. Rebars were wrapped with GFRP sheets connected to the external reinforcement (Figure 6).

2.5 Polypropylene jacketing

While extensive research was conducted for retrofitting of masonry structures using FRP, much less was reported for retrofitting of unreinforced masonry structures with polypropylene nets (Figure 7).

This research investigated the effectiveness of retrofitting on two sides of masonry panels. The mechanical characteristics of the polypropylene net with an approximate mesh size of $30 \times 45\text{mm}$, produced by Tenax, are given in Table 5. Through holes were drilled for $\phi 12\text{mm}$ GFRP rebars anchors at $5/\text{m}^2$. Through anchors wrapped with GFRP sheets were fixed to the polypropylene reinforcement using epoxy-resins as shown in Figure 8. The same hydraulic mortar used for FRP jacketing (IG type) was applied. The coating was applied by shotcreting and a thickness of coating of 15-25mm was used (approximately 15mm for brick panels and 25mm for stone panels).

Table 3
Mechanical characteristics of glass uni-directional fibre

Type	Alkali resistant
Number of specimens	6
Young modulus [N/mm ²]	87616
Weight density [kg/m ²]	0.6
Tensile strength [N/mm ²]	1778
Equivalent fibre thickness [mm]	0.23
Elongation at failure [%]	2.02

Table 4
Mechanical characteristics of glass FRP mesh

Tensile strength Trasv. [kNm ⁻¹]	24
Tensile strength Long. [kNm ⁻¹]	22
Young modulus Trasv. [N/mm ²]	450
Young modulus Long. [N/mm ²]	400
Weight density [kg/m ²]	0.138
Elongation at failure [%]	3.5
Fibre thickness [mm]	0.67

Table 5
Mechanical characteristics of polypropylene

Mesh [mm]	30 x 45
Weight density [kg/m ²]	0.14
Mesh Tensile strength [kN/m]	
Direction 1	9.3
Direction 2	17
Elongation at failure [%]	
Direction 1	16
Direction 2	13
Young Modulus [N/mm ²]	
Direction 1	70
Direction 2	65

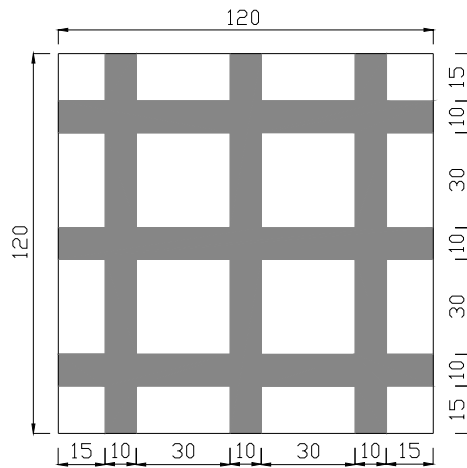

Figure 4 FRP jacketing (FV type): fibre layout (dimensions in cm)



Figure 5 GFRP mesh (IG type)



Figure 7 Polypropylene mesh



Figure 6 Connection between GFRP bar and sheet



Figure 8 Connection between through anchors and polypropylene reinforcement: bars are wrapped with GFRP sheets and fixed to the polypropylene mesh using epoxy-resins

3. COMPRESSION, SHEAR-COMPRESSION AND DIAGONAL TESTS ON PANELS

Compression, shear-compression and diagonal compression tests were carried out on site and in the laboratory with the aim of determining the shear and normal stiffness and strength of the masonry. On site the tests were carried out on panels cut from the load-bearing walls. The operation was performed by using a special cutting technique with diamond wires in order to avoid major damage to the panels.

Shear-compression tests (Figure 9) were carried out on panels of 900 x 1800mm dimension with thickness variable from 240 to 700mm. During the test, the masonry was subjected to a vertical constant stress σ_0 and simultaneously to an horizontal shear load T in the centre of the panel.

This test, even if it simulates better the state of stress of masonry under horizontal loads, is much more complicated than the diagonal test.

A compression test is usually carried out before the shear-compression test on the panels without reaching the failure, in order to determine first some masonry parameters such as the elastic modulus and the Poisson's ratio (Figure 10). For a more detailed description of the tests, see [12] and [15].

Concerning the shear-compression test, panels of dimension 1800 x 900mm can be considered as two half panels 900 x 900mm, one above the other. The initial value σ_0 of the vertical stress is known:

$$\sigma_0 = \frac{P_v}{A} \quad (1)$$

where P_v is the vertical compressive load and A is the area of the horizontal cross-section of the panel.

From the value of the maximum shear load reached, T_{iu} , the maximum shear stress τ_u is calculated for the bottom half panel in which generally the shear failure is attained before, due to the highest constraint level:

$$\tau_u = \frac{T_{iu}}{A} \quad (2)$$

Then the value of the corresponding principal tensile stress σ_l in the bottom half panel is expressed by the following relationship [16]:

$$\sigma_l = \sigma_0 \left[-\frac{1}{2} + \sqrt{\left(b \frac{\tau_u}{\sigma_0} \right)^2 + \frac{1}{4}} \right] \quad (3)$$

where b is a shape factor that takes into account the variability of the shear stresses on the horizontal section of the wall. This parameter is assumed by the Italian Standards and the well-known POR method equal to 1.5.

Through the values obtained in (1), (2), (3), the characteristic shear stress τ_k at the bottom half panel is calculated:

$$\tau_k = \frac{\sigma_l}{b} \quad (4)$$

The shear modulus G during the elastic phase is calculated with reference to the Sheppard static scheme assuming that the lower half panel, which is the most highly stressed, behaves as an elastic beam perfectly constrained at the bottom. This causes a lack of symmetry in the shear distribution between the upper and lower halves of the panel, which can be taken into account during the interpretation of the data. According to this hypothesis, the G modulus can be derived from (5) in which it is the only unknown:

$$\frac{\delta_E}{0.9T_{iu}} = \frac{1.2h}{GA} \left[1 + \frac{G}{1.2E} \left(\frac{h}{d} \right)^2 \right] \quad (5)$$

where d and h are the thickness and height of masonry panel; E is the elastic modulus obtained from the compression test. δ_E is the relative horizontal displacement between bottom and middle point of the panel assuming a linear elastic behaviour and it is calculated as indicated in Figure 11.

The on site diagonal compression test is the most frequently used and has now been assumed also by the Italian Seismic Code due to its simplicity and by Eurocode 6 [17]. The test is also standardized by ASTM [18].

The diagonal test was performed on site on panels of 1200 x 1200mm dimensions with sections of different thickness and morphology in laboratory and on site. The load is given by hydraulic jacks (Figure 12). In the case of the diagonal test, the calculated value of the shear stress τ is equal to the value of the principal stress σ_1 as follows:

$$\tau = \sigma_1 = \frac{P}{A\sqrt{2}} \quad (6)$$

where P is the diagonal compressive load generated by the hydraulic jack and A is the area of the horizontal cross-section of the panel. With reference to this interpretation of the test as defined by ASTM E 519-81 Standard, it is possible to calculate the characteristic strength of the masonry τ_k through:

$$\tau_k = \tau_u = \frac{P_{\max}}{A\sqrt{2}} \quad (7)$$

where τ_u is the ultimate shear strength.

Furthermore it is possible to calculate the shear stiffness $G_{1/3}$ (secant value of the modulus at 1/3 of the peak load) defined as:

$$G_{1/3} = \frac{\tau_{1/3} - \tau_i}{\gamma_{1/3} - \gamma_i} \quad (8)$$

where $\gamma_{1/3}$ is the angular strain at 1/3 maximum load, τ_i and γ_i are respectively the initial shear stress ($\tau_i = 0.002\text{N/mm}^2$) and strain values due to an application of a pre-load.

The angular strain is expressed as:

$$\gamma = \varepsilon_c + |\varepsilon_t| \quad (9)$$

where ε_c and ε_t are the strains associated with the panel diagonals.

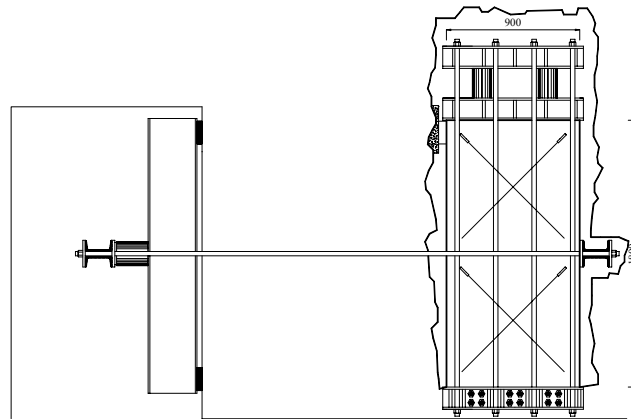

Figure 9 Shear compression test layout (dimensions in mm)

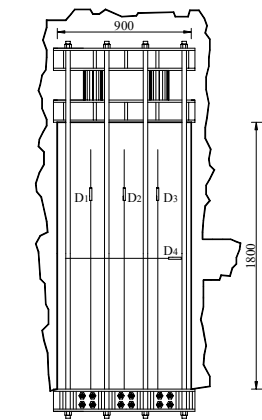

Figure 10 Compression test layout with position of the inductive transducers (dimensions in mm)

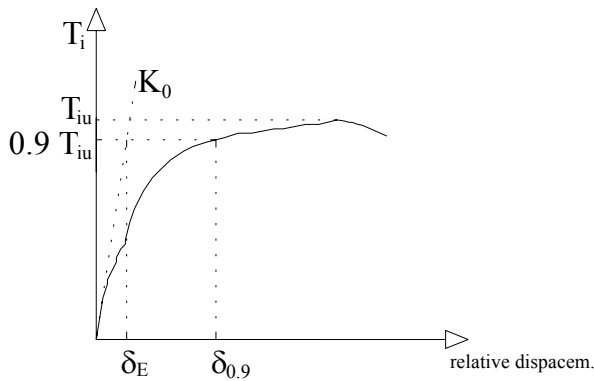

Figure 11 δ_E calculation procedure

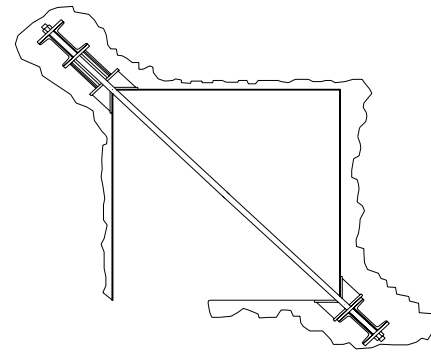

Figure 12 Diagonal compression test layout (panel dimensions 1200 x 1200mm)

4. SPECIMEN DESCRIPTION

Eleven panels tested in-situ were obtained from three buildings (located in Umbria, Italy in the villages of Farnetta, Turruta and Trevi). The buildings were chosen as being representative of the most common masonry textures in the Umbrian area. All the panels were cut from un-damaged walls. The panels are made with roughly cut stones. These walls are composed by two weakly connected leaves and a lime-based mortar.

Moreover a series of fourteen panels were built in the laboratory (Figure 13). Masonry panels were manufactured with solid clay bricks or calcareous stones. Eight specimens were built with pink-coloured calcareous stones. The remaining six were made of solid clay bricks (120 x 55 x 250mm) and have 10mm thick mortar joints. Their overall thickness was 240mm for clay specimens. In the case of the stone masonry walls the thickness varied from 490 to 510mm. The thickness was given by the average value detected for existing walls in the Umbrian areas struck by the earthquake in 1997. Stone panels were made of two roughly cut stone leaves with no constructive transversal connection. The two external leaves, approximately 200mm thick each, have the highest dimension of about 250mm, arranged in sub-horizontal courses, with mortar joints having thickness varying from 10 to 40mm. All specimens were allowed to cure for at least 90 days before testing. The main mechanical properties of the bricks were determined by unidirectional compressive and flexural tests. The characteristic compressive strength of thirty bricks was found to be equal to 20.99N/mm². Flexural tests on ten specimens provided an average value equal to 7.39N/mm².

Regarding the pink-coloured stone, four cylindrical samples (diameter = 72mm, height = 150mm) made of the stone were tested in compression. The results obtained from the tests carried out, show that, even if the density of these stones is sufficiently constant (average value equal to 2330kg/m³), the values of the strength depend significantly on the presence of inclusions, in random orientation, inside the samples. These caused a compression strength decrease of up to 60% compared to the highest values measured. The compression strength of sample number 3 is equal to 90.3N/mm² while the average value is 57.5N/mm². The stone used for the construction combined the exigencies of reproducing historical walls conditions and of using local and easy-to-find materials.

Mortar used for the masonry panels had the following mix composition in volume: 33% lime-based mortar; 66% of sand. The flexural and compressive standard tests on six

specimens (40 x 40 x 160mm) after a period of 28 days of curing revealed an average strength equal to 0.59N/mm² and 1.06N/mm², respectively.

The panels are identified by a five index code, in which the first indicates the type of test (CD = diagonal compression, TC = shear-compression, CS = compression), the second the identification number of the panel; the third the location of the building from which the panels were obtained (F = Farnetta, M = Turruta, L = built in the laboratory, T = Trevi), while the fourth index indicates the type of retrofitting method carried out (OR = un-strengthened panel, SI = deep repointing and injections, IT = ferrocement, IP = polypropylene jacketing, IG = GFRP grid, IN = grout injections, RI = deep repointing, FV = GFRP unidirectional sheets). The last index indicates the panel condition (R = panel repaired, P = preventive reinforcement-virgin panel). All types of reinforcement were applied on both sides of the masonry panels.

5. EXPERIMENTAL RESULTS

5.1 Compression tests

Since compression tests are designed to find the stiffness characteristics (Young's Modulus for masonry) they are non-destructive experiments even though the stresses applied, though limited, caused a non-linear reaction with small residues at unloading.

5.1.1 Unreinforced panels

These tests were carried out on Farnetta building and in laboratory. In detail, three panels of dimension 1800 x 900 x 480mm, were subjected to the following cycles of tests in Farnetta: N.3 tests before reinforcement and the same three panels reinforced with GFRP jacketing and deep repointing-injection.

Results of Young modulus for the first loading-unloading cycle E_1 and average value E_{aver} obtained from all cycles, are reported in Table 6.

Considering the notable variations in results typical of tests on masonry, the scattering of the Young modulus results obtained with the in-site experimental work is not very high. The average values of Young modulus E_1 and E_{aver} are respectively 463 and 301N/mm².

With regard to the compression tests carried out in laboratory, the average value of Young's modulus of elasticity E_{aver} was 1358N/mm² and 1697N/mm² respectively for double-leaf stone panels and single-leaf solid brick masonry panels.



Figure 13 Panels built in the laboratory

Table 6
Results of compression tests

Test No.	Panel dimensions (cm)	Masonry texture	Maximum compression stress σ_0 (N/mm ²)	Young modulus E_1^* (N/mm ²)	Young modulus E_{aver} (N/mm ²)
CS-01-F-OR	86x48x182	1)	0.201	127	129
CS-01-F-SI-R	86x48x182	1)	0.286	8255	4153
CS-02-F-OR	86.3x48x180	1)	0.215	470	306
CS-02-F-SI-R	86.3x48x180	1)	0.286	1889	1770
CS-05-F-OR	90x48x180	1)	0.200	792	469
CS-05-F-IG-R	90x48x180	1)	0.196	402	293
CS-22-L-OR	89x24.5x181	2)	0.435	3588	2983
CS-31-L-IT-P	91x59x181	1)	0.160	5778	4201
CS-35-L-OR	90x48.6x190	1)	0.204	729	567
CS-35-L-IP-R	90x54.5x180.5	1)	0.206	2836	2130
CS-36-L-OR	181x90x49	1)	0.195	1388	988
CS-36-L-IG-R	182x90x51	1)	0.191	1886	1724
CS-37-L-OR	90x51x180.5	1)	0.177	3082	1965
CS-37-L-IT-R	92x59x180	1)	0.189	6930	5082
CS-38-L-IG-P	90x51x182	1)	0.189	2219	1888
CS-39-L-OR	90x48.6x190	1)	0.185	2411	1913
CS-39-L-IP-R	90x52x190	1)	0.117	777	832
CS-42-L-OR	90x25x179	2)	0.203	1404	905
CS-42-L-IP-R1	90x26x180	2)	0.199	634	848
CS-43-L-IG-P	90x25.5x180	2)	0.198	2108	2898
CS-44-L-OR	92.5x25x180	2)	0.194	1830	1204
CS-44-L-IT-R	92.5x34.5x180	2)	0.197	2101	1818

1) Double-leaf roughly cut stone masonry panel; 2) Single-leaf solid brick masonry panel

5.1.2 Retrofitted panels

The in-site panels were repaired with GFRP jacketing (1 panel) and deep repointing-injections (2 panels). In Table 6 the detailed results of the compression tests before and after repair are given. The result for the Young modulus E_{aver} was 301N/mm² for un-strengthened panels (CS-01-F-OR, CS-02-F-OR, CS-05-F-OR), while it reached 2961N/mm² in the case of strengthened panels with deep repointing-injections (CS-01-F-SI-R, CS-02-F-SI-R). In Figure 14 the stress-strain results of the same tests are presented. It can be easily seen that the increase in elastic modulus was extremely high. Nevertheless high scatter in the results was found, as expected from such irregular masonry.

For the panel repaired with GFRP jacketing, the reinforcement did not cause an increase of the Young's modulus.

Concerning the panels tested in laboratory, three different jacketing methods were used: concrete (ferrocement), GFRP (IG type) and polypropylene jacketing.

In order to study the influence of the retrofitting technique applied as preventive and repair work, the ferrocement reinforcement was applied on both un-damaged and damaged masonry panels; this retrofitting technique caused a very high increase in stiffness (stone panels: retrofitted $E_{aver} = 4641\text{N/mm}^2$, unreinforced $E_{aver} = 1358\text{N/mm}^2$), but an un-significant difference was found between undamaged and damaged panels.

Repair or preventive reinforcement with polypropylene or GFRP (IG type) are not able to increase significantly the original stiffness of masonry panels.

5.2 Shear-compression tests

The shear-compression tests were successively carried out on the same panels used for the compression tests.

5.2.1 Unreinforced panels

Ten unreinforced masonry panels were tested under shear-compression test setup. All the panels failed due a shear-friction crack along the diagonal of the lowest half panel.

For double-leaf roughly cut stone masonry panels, the typical shear failure was observed on both sides of the panels, with a characteristic shear strength τ_k and shear modulus G respectively of 0.090N/mm^2 and 110N/mm^2 .

Solid brick panels, although stepped shear friction cracks were observed, failed due to shear slide at the bed joints (Figure 15), with a characteristic shear strength τ_k of 0.188N/mm^2 and a shear modulus G of 207N/mm^2 . The test results are compared in Table 7.

5.2.2 Retrofitted panels

With regard to the strengthening with traditional ferrocement, the first shear-compression tests carried out on panels in the laboratory highlighted that this seismic upgrading technique is effective both for reinforcement of undamaged masonry

and for repair, but it causes very high increases of shear stiffness ($\tau_k = 0.205\text{N/mm}^2$, +127%; $G = 630\text{N/mm}^2$, +472%). For tests TC-31-L-IT-P, TC-37-L-IT-R and TC-44-L-IT-R, no clear cracks were observed and the failure was caused by a debonding of concrete jacketing from masonry surface (Figure 16).

The results obtained for the shear-compression tests carried out on panels repaired by means of injection and deep repointing showed significant high increases both in terms of shear strength τ_k (+362%) and stiffness G (+362%) compared to the same un-strengthened panels. However, it must be pointed out that the presence of cracks (these cracks were caused by the initially tests on the same un-strengthened panels) facilitated the distribution of the injected grout within the panels. The results are shown in Table 7 and in Figure 17.

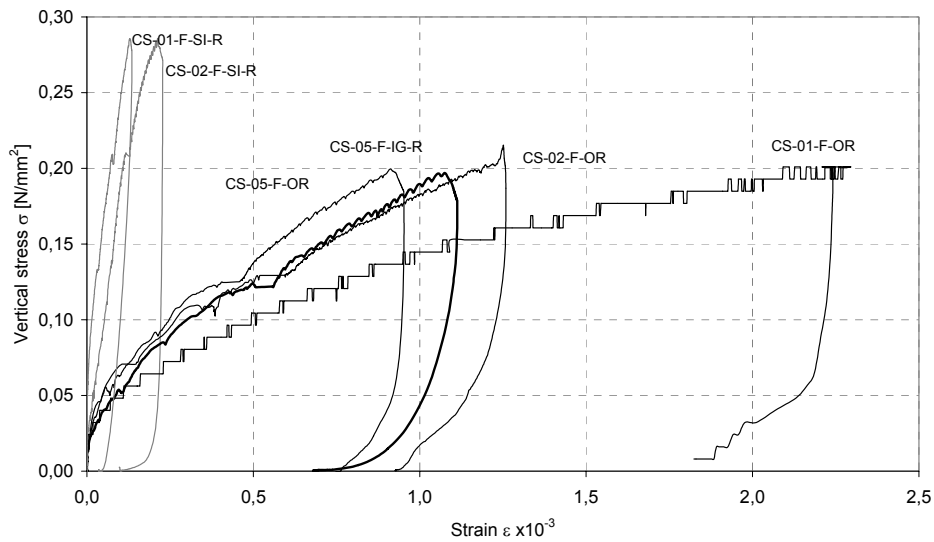

Figure 14 Compression tests: stress-strain plot for panels tested in-situ



Figure 15 Unstrengthened brick panel: failure mechanism



Figure 16 Ferro-cement: failure mechanism

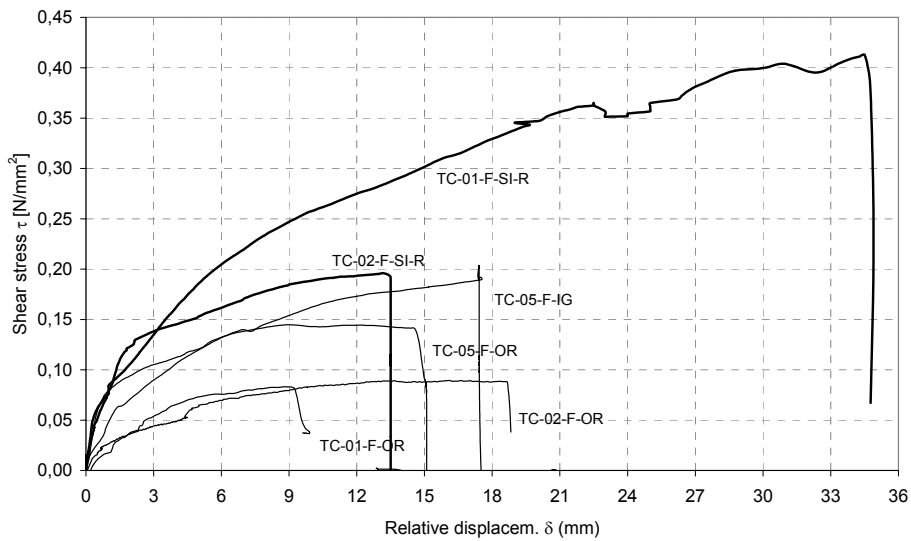

Figure 17 Shear-compression tests: stress-strain plot for panels tested in-site

Table 7
Results of shear-compression tests

Test no.	Panel dimensions (cm)	Masonry texture	Shear strength τ_u (n/mm ²)	Compression stress σ_0 (n/mm ²)	Shear charact. strength τ_k (n/mm ²) $b=1.5$	Shear modulus G (n/mm ²)
TC-01-F-OR	86x48x182	1)	0.083	0.1467	0.047	37.9
TC-01-F-SI-R	86x48x182	1)	0.412	0.2720	0.331	281
TC-02-F-OR	86.3x48x180	1)	0.089	0.1838	0.047	65.4
TC-02-F-SI-R	86.3x48x180	1)	0.196	0.2683	0.103	196
TC-05-F-OR	90x48x180	1)	0.145	0.1835	0.096	101
TC-05-F-IG-R	90x48x180	1)	0.204	0.1851	0.151	43.6
TC-22-L-OR	89x24.5x181	2)	0.385	0.4460	0.265	309
TC-31-L-IT-P	91x59x181	1)	0.221	0.164	0.173	732
TC-35-L-OR	90x48.6x180.5	1)	0.238	0.202	0.180	77.0
TC-35-L-IP-R	90x54.5x180.5	1)	0.147	0.178	0.099	309
TC-36-L-OR	90x49x181	1)	0.093	0.187	0.050	201
TC-36-L-IG-R	90x51x182	1)	0.293	0.194	0.235	315
TC-37-L-OR	90x51x180.5	1)	0.108	0.180	0.064	154
TC-37-L-IT-R	92x59x180	1)	0.176	0.156	0.131	570
TC-38-L-IG-P	90x51x182	1)	0.162	0.131	0.124	333
TC-39-L-OR	90x48.6x190	1)	0.187	0.136	0.147	133
TC-39-L-IP-R	90x52x190	1)	0.124	0.179	0.078	343
TC-42-L-OR	90x25x179	2)	0.185	0.252	0.120	100
TC-42-L-IP-R1	90x26x180	2)	0.272	0.378	0.174	234
TC-43-L-IG-P	90x25.5x180	2)	0.306	0.316	0.218	242
TC-44-L-OR	92.5x25x180	2)	0.243	0.219	0.180	211
TC-44-L-IT-R	92.5x34.5x180	2)	0.367	0.186	0.310	588

1) Double-leaf roughly cut stone masonry panel; 2) Single-leaf solid brick masonry panel

For panels retrofitted with a GFRP grid, the strengthening constrained the development of the cracks, and failure was confined by the GFRP jacketing. The panel lateral resistance (τ_k) increased to 0.182N/mm^2 , i.e. the GFRP enhanced the lateral resistance by a factor of approximately 1.61 compared to the same panels before reinforcement, but shear stiffness G decreased from 276 to 231N/mm^2 . The ultimate limit state was clearly a shear failure that was initiated by tensile rupture in grid fibre reached when the masonry cracked in tension.

For panels retrofitted with a polypropylene net, the results indicated that in-plane strength was not increased using this reinforcement. The three panels repaired with polypropylene nets failed with a lateral resistance of 0.117N/mm^2 . The shear strength of the same three panels before reinforcement was 0.149N/mm^2 . Failure occurred when the loading produced diagonal cracks in the lowest half panel and high bond stresses between the polypropylene fabric and the masonry substrate causing delamination of the reinforcement and the collapse of the panel. The delamination was because of poor bonding between FRP and masonry surface due to the use of hydraulic mortar.

5.3 Diagonal compression tests

These tests were carried out on all buildings and in laboratory. A total number of nineteen tests were executed. Strain and load measurements allow us to establish stress-strain diagrams for the tested panels.

5.3.1 Unreinforced panels

With regard to unreinforced panels the stress-strain curves show a plastic behaviour with a large yield plateau. All the unreinforced panels present the failure along the compressed diagonal. Cracking appeared suddenly in the mortar joints and in the bricks for single-leaf solid brick masonry panels. For roughly cut stone masonry panels cracking appeared only in the mortar joints. The shear strength τ_k was 0.042N/mm^2 for stone panels while the shear modulus $G_{1/3}$ was 179N/mm^2 . Results are summarized in Table 8.

Two panels tested under diagonal compression consisted of a different masonry texture, made only of solid brick. These unreinforced panels presented a brittle failure along the compressed diagonal, with cracks that appeared suddenly in the mortar joints and in the bricks, producing the instantaneous failure of the walls. A shear strength τ_k and shear modulus $G_{1/3}$ respectively of 0.102N/mm^2 and 728N/mm^2 were measured.

5.3.2 Retrofitted panels

For the strengthened masonry panels subjected to the diagonal compression, let us consider the force vs. angular strain curves of the masonry walls tested in-site (Figure 18).

As expected, the panel reinforced with ferrocement resulted very stiff ($G_{1/3} = 543\text{N/mm}^2$). Shear strength was 0.250N/mm^2 . The stress-strain curve shows a quasi-elastic behaviour with a weak yield plateau. The failure mechanism

consisted in sudden loss of collaboration between reinforcement (concrete) and substrate (masonry) with no cracks along the compressed diagonal observed on concrete surface.

The results obtained for the diagonal compression tests carried out on panels repaired by means of injection showed significant high increases both in terms of shear strength and stiffness. The strength and stiffness values became, respectively, 0.108 and 240N/mm^2 with an increment of 127% and 199% compared to the values measured for the same panels before reinforcement. This result substantially showed that the injection technique is effective when used as a repair technique. The failure modes observed for these panels are characterized by a very similar cracking pattern as those of the unreinforced panels.

Two diagonal tests were carried out on the Trevi building (CD-26-T-ORI, CD-26-T-RIR). The panel with a thickness of 670mm was only repaired by deep repointing in order to check the influence of deep-repointing technique when used alone. In this case the shear strength τ_k change from the un-repaired panel to the panel after repair, is from 0.045N/mm^2 to 0.054N/mm^2 , which is only a very small increase in value. On the contrary, the shear stiffness $G_{1/3}$ changed from 79.6N/mm^2 to 232N/mm^2 . From these results, a clear tendency is shown: the deep repointing alone can increase the shear stiffness of the masonry, while a significant increase in shear strength can be obtained by the synergic effect of repointing and grout injection. It is nevertheless important before using the grout injection technique to examine its applicability. A certain percentage of voids must be present in the masonry and no loose material or clay must be found inside the masonry section, in order to have a successful injection.

For the repaired panels with GFRP (FV type), the diagrams underline two stages of the global behaviour: a first elastic and a second plastic. The elastic phase of the curves of the reinforced panels are characterized by a similar slope to those of the unreinforced panels. The gain in strength τ_k is quite significant: 186% for stone panels and 170% for the brick panel (CD-21-L-FV-R). Thus, a first consequence of the reinforcement is the increase of the strength of the wall while restoring part of the initial in-plane stiffness. The adhesion between the panel and the epoxy plaster, used as a base for the fibres, did not fail (Figure 19). For stone panels the crisis resulted from a separation of the two masonry leaves and from masonry local cracking at unreinforced zones.

The results obtained for the diagonal compression tests carried out on the panel repaired by means of injection and deep repointing showed significant increase both in terms of shear strength τ_k and stiffness $G_{1/3}$. It is significant to note that the injection and deep repointing techniques, when applied to suitable masonry, causes a strong increase in shear stiffness. Panels repaired with this technique and re-tested showed increases with minimum values of 3 times superior to those obtained on the same panels previously tested before strengthening.

Table 8
Results of diagonal compression tests

Test no.	Panel dimensions (cm)	Masonry Texture	Shear charact. strength τ_k (n/mm ²)	Shear modulus $g_{1/3}$ (n/mm ²)	Angular strain $\gamma_{1/3}$
CD-03-F-OR	120x119x48	1)	0.046	105	0.145
CD-03-F-IN-R	120x119x48	1)	0.086	289	0.100
CD-04-F-OR	120x120x48	1)	0.049	55.5	0.284
CD-04-F-IN-R	120x120x48	1)	0.130	191	0.227
CD-06-F-IT-P	120x120x54	1)	0.250	543	0.157
CD-08-L-OR	120x120x48	1)	0.042	352	0.039
CD-20-L-OR	119x120x24.5	2)	0.090	600	0.048
CD-21-L-OR	119x120x24.5	2)	0.115	856	0.045
CD-21-L-FV-R	119x120x24.5	2)	0.311	975	0.093
CD-23-M-OR	120x121x45	1)	0.040	165	0.030
CD-23-M-FV-R	120x121x45	1)	0.168	38.1	1.473
CD-24-M-FV-R	118x110x45	1)	0.094	83.3	0.382
CD-25-T-OR	118x120x67	1)	0.050	364	0.046
CD-25-T-FV-R	118x120x67	1)	0.100	91.2	0.362
CD-26-T-OR	125x123x67	1)	0.045	79.6	0.190
CD-26-T-RI-R	125x123x67	1)	0.054	232	0.076
CD-27-T-IG-P	121x120x69	1)	0.089	318	0.088
CD-41-L-OR	119x121x48	1)	0.025	132	0.039
CD-41-L-IP-R1	119x121x48	1)	0.119	468	0.075

1) Double-leaf roughly cut stone masonry panel; 2) Single-leaf solid brick masonry panel

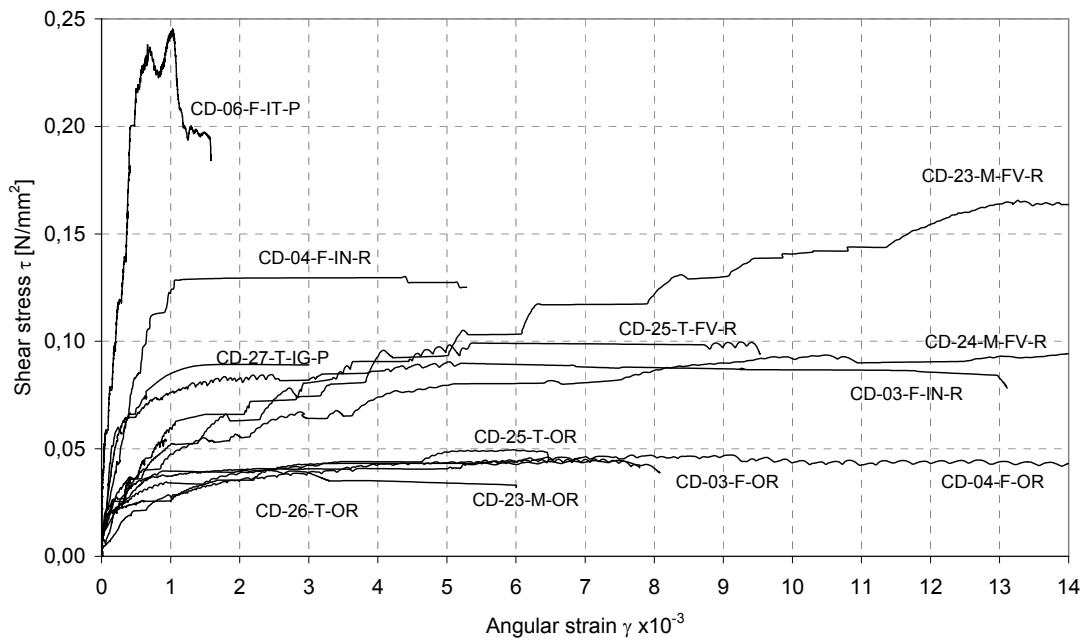

Figure 18 Panels tested in-site: shear stress vs. angular strain



Figure 19 A panel retrofitted with GFRP sheets

6. CONCLUSIONS

Brick and double-leaf stone masonry constitutes a construction type that is very common in structures belonging to the built cultural heritage in Europe. This study presents an experimental investigation on the behavior of in-plane loaded masonry panels retrofitted with traditional and innovative methods and the results of the experiments carried out, although varying according to the test performed, have highlighted their limitations as well as their advantages. In particular, glass fibre reinforced composites are very cost effective and versatile. Even though these types of materials have shown remarkable short-term performance in strengthening applications, their long-term durability and performance should be investigated before widespread field applications.

The following conclusions may be drawn from this study.

1. Traditional retrofitting methods like ferrocement and grout injections are effective, but cause very high increases in shear stiffness. The results substantially show that while the injection technique can be effective when used as a repair technique, its adoption on undamaged structures needs a prior careful analysis of the masonry texture and characteristics in order to understand if the grout can be properly distributed within the masonry.
2. Deep repointing up to a depth of 70 to 80mm alone produces a limited increase of the shear strength and of the shear stiffness of masonry made with roughly cut stones compared to the virgin masonry.
3. The combined confinement effect of existing transverse reinforcement and external GFRP jacketing, which determines the behaviour of retrofitted elements, was examined experimentally on both damaged and undamaged masonry elements.
4. The externally applied GFRP wet lay-up composite applied (with an epoxy resin) to masonry panels resulted in a stronger system, as compared to the unreinforced configuration. The addition of the GFRP sheet resulted in a 186% increase (stone panels) in lateral resistance.
5. The FRP grid upgrade with hydraulic mortar coatings is promising; but less effective than the reinforcement with epoxy resins. It improved the shear strength by a factor of 1.61.
6. Polypropylene jackets did not enhance the strength of masonry under lateral load.
7. Use of lime-based coatings: the tests have highlighted the fact that the adhesion between the panels and the lime-based mortars used as a base for reinforcements (GFRP and polypropylene nets) was the weakest element in the system. The failure resulted from the separation of the layer of lime-based mortar from the masonry panels.

ACKNOWLEDGEMENTS

This paper is based on the results of the project: "Analisi sperimentale in situ e in laboratorio delle caratteristiche meccaniche delle murature rinforzate e non" carried out by the RITAM laboratory located in Terni, supported by the Deputy Commissioner for interventions in the Umbrian areas struck by the earthquake. Special thanks go to Dr. A. Annunziata, G.F. Montani, M. Martellino, A. Giannantoni and F. Gualberto. Thanks also go to Sika s.r.l., I.A.R. S.r.l., TENAX S.p.A. and Mac S.p.A. for their technical assistance during the strengthening operations.

REFERENCES

1. TOMAZEVIC, M. and ALIH, V. The strengthening of stone-masonry walls by injecting the masonry-friendly grouts. 7th European Conf. On Earthquake Engineering, 1, 10-20, 1993.
2. BINDA, L., MODENA, C., BARONIO, G. and ABBANEO, S. Repair and investigation techniques for stone masonry walls, *Construction and Building Materials*, Elsevier, 11, (3), 133-142, 1997.
3. VINTZILEOU, E. and TASSIOS, T.P. Three-leaf stone masonry strengthened by injecting cement grouts, *Journal of Structural Engineering*, 121, (5), 848-856, 1995.
4. CHIOSTRINI, S., GALANO, L. and VIGNOLI, A. In Situ Shear and Compression Tests in Ancient Stone Masonry Walls of Tuscany, Italy, *Journal of Testing and Evaluation*, ASTM, 31, (4), 289-304, 2003.
5. SCHWEGLER, G. Masonry construction strengthened with composites in seismically endangered zone, *Proceedings of 10th European Conference on Earthquake Engineering*, Vienna, Austria, A.A. Balkema Publ., Rotterdam, 2299-2303, 1994.

6. ESHANI, M.R. Strengthening of earthquake damaged masonry structures with composite materials, Non-metallic (FRP) Reinforcement for Concrete Structures, Proceedings of the second international *RILEM Symposium FRPRCS-2*, L. Taerwe Ed., E & FN Spon, London, England, 681-687, 1997.
7. GABOR, A., BENNATI, A., JACQUELIN, E. and LEBON, F. Modelling approaches of the in-plane shear behaviour of unreinforced and FRP strengthened masonry panels, *Composite Structures*, Elsevier, (74), 277–288, 2006.
8. ELGAWADY, M.A., LESTUZZI, P. and BADOUX, M. Analytical model for the in-plane shear behavior of URM walls retrofitted with FRP, *Composites Science and Technology*, Elsevier, (66), 459–474, 2006.
9. ASCIONE, L., FEO, L. and FRATERNALI, F. Load carrying capacity of 2D FRP/strengthened masonry structures, *Composites: Part B*, Elsevier, 36, 619–626, 2005.
10. CECCHI, A., MILANI, G. and TRALLI, A. In-plane loaded CFRP reinforced masonry walls: Mechanical characteristics by homogenisation procedures, *Composites Science and Technology*, (64), 13-14, 2097-2112, 2004.
11. CORRADI, M., BORRI, A. and VIGNOLI, A. Strengthening techniques tested on masonry structures struck by the Umbrian-Marche earthquake of 1997-1998, *Construction and Building Materials*, Elsevier, 16, (4), 229-239, 2002.
12. CORRADI, M., BORRI, A. and VIGNOLI, A. Experimental study on the determination of strength of masonry walls, *Construction and Building Materials*, Elsevier, 2003, (17), 325-337.
13. VALLUZZI, M.R., TINAZZI, D. and MODENA, C. Shear behavior of masonry panels strengthened by FRP laminates, *Construction and Building Materials*, Elsevier, (16), 409–416, 2002.
14. CORRADI, M., TEDESCHI, C., BINDA, L. and BORRI, A. Experimental evaluation of shear and compression strength of masonry wall before and after reinforcement: deep repointing, *Construction and Building Materials*, Elsevier (in press).
15. CHIOSTRINI, S. and VIGNOLI, A. In-situ determination of the strength properties of masonry walls by destructive shear and compression tests, *Masonry International*, 7, (1), 1994, 87-96.
16. TURNSEK, V. and SHEPPARD, P.F. The shear and flexural resistance of masonry walls, Proc. of the research conf. on earthquake engineering., Skopje, 1980.
17. EUROCODE 6 Design of masonry structures – Part 1-1: General rules for buildings – Rules for reinforced and unreinforced masonry. ENV 1996-1-1:1995.
18. ASTM E 519-81 Standard Test Method for Diagonal Tension (Shear) in Masonry Assemblages, *American Society for Testing Materials*, 1981.