



UNIVERSITÀ
DEGLI STUDI
FIRENZE

FLORE

Repository istituzionale dell'Università degli Studi di Firenze

Clean energy from the ground: new technologies for a sustainable use of geothermal resources

Questa è la Versione finale referata (Post print/Accepted manuscript) della seguente pubblicazione:

Original Citation:

Clean energy from the ground: new technologies for a sustainable use of geothermal resources / Manfrida G.. - STAMPA. - (2012), pp. 79-93. (CPOTE 2012 Contemporary Problems of Thermal Engineering18-20 Settembre 2012).

Availability:

The webpage <https://hdl.handle.net/2158/796257> of the repository was last updated on

Publisher:

ITC Gliwice Poland

Terms of use:

Open Access

La pubblicazione è resa disponibile sotto le norme e i termini della licenza di deposito, secondo quanto stabilito dalla Policy per l'accesso aperto dell'Università degli Studi di Firenze (<https://www.sba.unifi.it/upload/policy-oa-2016-1.pdf>)

Publisher copyright claim:

La data sopra indicata si riferisce all'ultimo aggiornamento della scheda del Repository FloRe - The above-mentioned date refers to the last update of the record in the Institutional Repository FloRe

(Article begins on next page)

CLEAN ENERGY FROM THE GROUND: NEW TECHNOLOGIES FOR A SUSTAINABLE USE OF GEOTHERMAL RESOURCES

Giampaolo Manfrida

Dipartimento di Energetica “Sergio Stecco”
Università degli Studi di Firenze
Viale Morgagni 40, 50135 Firenze, Italy
e-mail: manfrida@unifi.it

Keywords: Geothermal Energy, Binary cycles, Organic Rankine Cycles, Combined Heat and Power, District Heating, Solar Energy Integration, Enhanced Geothermal Systems

Abstract

New technologies allow to consider the use of geothermal energy in a more sustainable way as compared to the past. Care to avoiding emissions, minimizing soil and water pollution, and correct cultivation of the geothermal resource can today render geothermal energy conversion and utilization one of the most environment-friendly energy resource, compatible with industrial growth and with the present development of society in OECD or in growing economies countries. Extension for the use of medium and even low-temperature resources from thermal usage to energy conversion is becoming possible, and Enhanced Geothermal Systems (EGS) can create artificially the resource also in regions which were not considered until a few years ago. These technologies are based on the employment of binary cycles, that is, avoiding contact of the geo-fluid with the atmosphere and using the geothermal resource in an almost closed loop. Success of these technologies depend on correct overall design, with an important contribution demanded to thermodynamicists and plant and process engineers who must apply correct solutions – the final success and substitution of the large installed capacity represented by present-day direct-expansion power plants will depend substantially on this factor.

Integration of geothermal with solar energy, combined heat and power with its associated load management problems, and management and upgrade of the resource, taking care of progressive exhaustion of the field and of the seasonal conditions, are other topics which will be more and more need developed skills in order to demonstrate that the use of this clean and abundant resource is sustainable, reliable, and economically attractive.

1. Introduction

Geothermal energy represents a relevant natural resource, which is widely available in many regions of the world. With reference to Europe (Figure 1), high-enthalpy resources ($T > 150^{\circ}\text{C}$) exist in some Mediterranean countries, while in many others medium-enthalpy ($100 < T < 150^{\circ}\text{C}$) geo-fluid can be found.

CLEAN ENERGY FROM THE GROUND: NEW TECHNOLOGIES FOR A SUSTAINABLE USE OF GEOTHERMAL RESOURCES

Giampaolo Manfrida

Dipartimento di Energetica “Sergio Stecco”
Università degli Studi di Firenze
Viale Morgagni 40, 50135 Firenze, Italy
e-mail: manfrida@unifi.it

Keywords: Geothermal Energy, Binary cycles, Organic Rankine Cycles, Combined Heat and Power, District Heating, Solar Energy Integration, Enhanced Geothermal Systems

Abstract

New technologies allow to consider the use of geothermal energy in a more sustainable way as compared to the past. Care to avoiding emissions, minimizing soil and water pollution, and correct cultivation of the geothermal resource can today render geothermal energy conversion and utilization one of the most environment-friendly energy resource, compatible with industrial growth and with the present development of society in OECD or in growing economies countries. Extension for the use of medium and even low-temperature resources from thermal usage to energy conversion is becoming possible, and Enhanced Geothermal Systems (EGS) can create artificially the resource also in regions which were not considered until a few years ago. These technologies are based on the employment of binary cycles, that is, avoiding contact of the geo-fluid with the atmosphere and using the geothermal resource in an almost closed loop. Success of these technologies depend on correct overall design, with an important contribution demanded to thermodynamicists and plant and process engineers who must apply correct solutions – the final success and substitution of the large installed capacity represented by present-day direct-expansion power plants will depend substantially on this factor.

Integration of geothermal with solar energy, combined heat and power with its associated load management problems, and management and upgrade of the resource, taking care of progressive exhaustion of the field and of the seasonal conditions, are other topics which will be more and more need developed skills in order to demonstrate that the use of this clean and abundant resource is sustainable, reliable, and economically attractive.

1. Introduction

Geothermal energy represents a relevant natural resource, which is widely available in many regions of the world. With reference to Europe (Figure 1), high-enthalpy resources ($T > 150^{\circ}\text{C}$) exist in some Mediterranean countries, while in many others medium-enthalpy ($100 < T < 150^{\circ}\text{C}$) geo-fluid can be found.

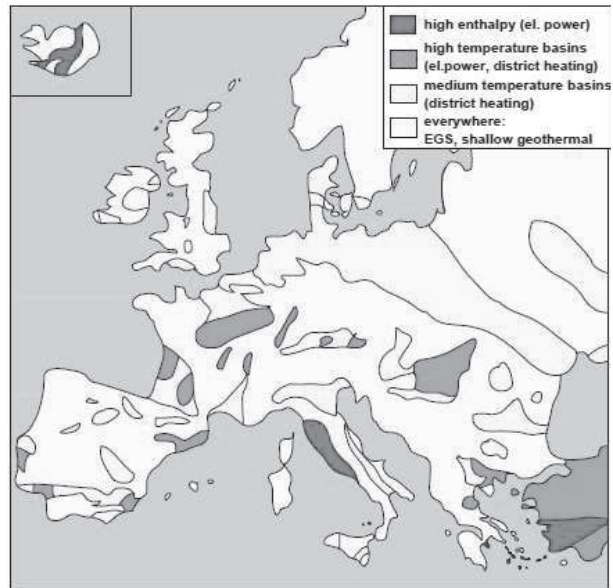

Figure 1: Distribution of geothermal resources in European countries (source: EGEC)

Low-enthalpy ($T < 100^{\circ}\text{C}$) resources are currently addressed to direct heat utilization: flowers and plant nurseries, fisheries, and district heating through progressive development of long distribution networks (the production wells are usually located away from towns and industrial users). The use of the geothermal resource started in Italy at the beginning of the 20th century (Figure 2), in the area of Larderello, Regione Toscana.

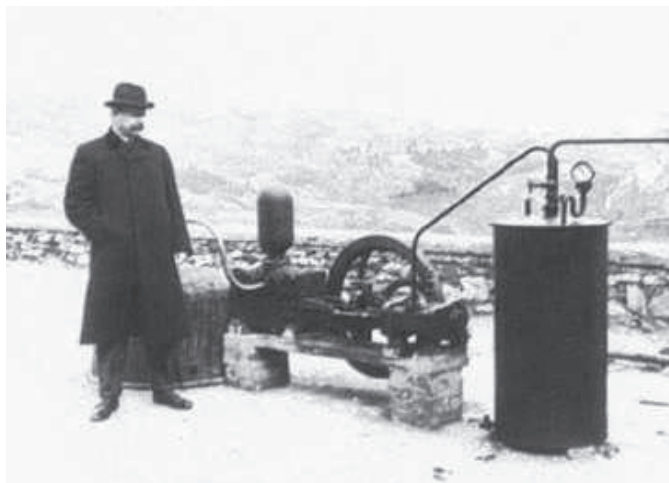

Figure 2: Count Ginori Conti demonstrates energy conversion from geothermal steam (Larderello, 1911)

2. Present development of geothermal energy conversion

According to recent worldwide statistics [1], all over the world over 10,000 MW of electric power are produced from geothermal resources. In Tuscany, the historical production site of Larderello sees an installed capacity of more than 650 MW (direct dry-steam expansion), and since

the 1970s new plants were built in the Monte Amiata field (single- or double-flash units), for a total in the region exceeding 730 MW (Figure 3). Having very high availability records (over 7000 h/year operation), these plants are responsible for an yearly electric energy production of nearly 6000 GWh/year, over a total production in Tuscany of about 20000 GWh/year. As Tuscany's import/export of electricity is substantially balanced, geothermal energy represents 30% of the total, and gives a notable contribution to the green image of the region (in Tuscany, over 40% of electricity is coming from renewable sources).



Figure 3: Location and size of geothermal power production sites in Tuscany, Italy

The question can be posed if geothermal energy can really be considered as a renewable resource. The typical expected time span for an investment in geothermal energy is not more than 50 years; however, experience has demonstrated that even intensively exploited geothermal fields (such as Larderello) can maintain and even recover productivity if they are correctly managed, with special reference to the care of the overall water balance (re injection of geothermal fluid is a standard since the 1980s). Geophysical investigations have indicated that the return time of rain water into a geothermal reservoir is typically in the range of 30 to 50 years (if not more, depending on local situations). In these terms, geothermal energy can be considered a renewable resource, as its typical availability timescale exceeds what is considered the lifetime of the power plant (even with life extension applied): the situation is not much different (at least for Mediterranean regions) from hydroelectricity, which is suffering from the diminishing natural resource (yet, hydroelectric energy is commonly considered as renewable). Moreover, geological survey indicate that there is a significant and promising development potential (well beyond the installed capacity), which again is a point in favor to geothermal energy with respect to hydroelectric.

Further development of geothermal energy conversion, however, depends on the sustainability issues. Most of the installed capacity (Table 1) belongs to three types of power plants: dry-steam, single-flash, double flash. All of these categories apply direct expansion of the geo-fluid in a turbine, with final contact with the atmospheric environments and release of incondensable gases (CO₂ – often 5 to 7% of the steam flow rate -, and in minor quantities H₂S, Hg, NH₃, As, ...). Even if plants have been refurbished with efficient but expensive chemical treatment units [2], the issue of CO₂ emissions remains (in Tuscany, over 1,4 Mton of CO₂ per year; not much less than a combustion power plant of similar overall capacity). Also the well drilling activity, from the exploration stage, puts several environmental problems (contaminated sludge management, noise, emissions from power production equipment,...). The experience in Italy is that local opposition

can be very strong, especially if plants of the conventional type are proposed. This discourages investors, as local and regional administrators cannot in practice guarantee the issue of final permits of operation, over the long time scale which is needed for return of investment. As well drilling down to significant depths (2000-5000 m) is very expensive, investors are currently not interested in power plants smaller than 5-10 MWe; typically, construction of a geothermal power plant totals 3000 to 5000 €/kW including well drilling and preliminary assessment operations, so that a high investment of capital, with a high risk and a long return time results.

Table 1: Distribution of geothermal power plants per type of power cycle

Type of plant	Capacity, MW (2007)	Fractional capacity
Dry-steam	2471	26%
Single-flash	4015	43%
Double-flash	2192	23%
Flash-Binary	363	4%
Binary	373	4%
Overall	9414	100%

Among the power plant types listed in Table 1, only binary or flash-binary (this last with special arrangements) allow to avoid contact of the geo-fluid with the atmosphere. In order to convince the public opinion, it is important to be able to propose solutions of this type, and to be able to show their benefits in comparison to traditional arrangements.

3. Geothermal power plants of current technology

3.1. Single and double flash

A single-flash geothermal power plant is a simple energy conversion unit (Figures 4 ad 5), working from a pressurized water resource originally available at T_{well} .

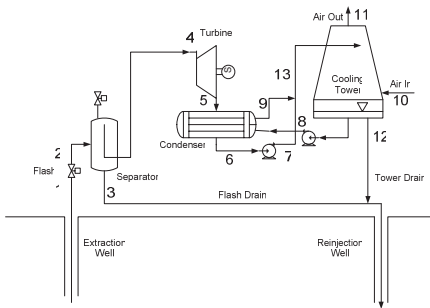

Figure 4: Single-Flash Power Plant Layout

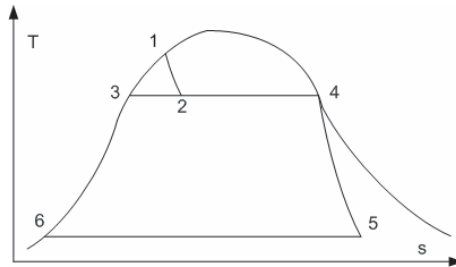

Figure 5: Single-Flash – Thermodynamic Cycle

The cooling tower loop operates on large flow rates of condensate, which are recirculated before reinjection, and are used for heat rejection to the atmospheric environment. It is here that incondensables are in contact with the atmosphere.

The combination of the well characteristic (flow rate vs. separator pressure – which is regulated by the throttle valve 1-2) with the thermodynamic cycle efficiency determines optimum conditions for overall efficiency [1, 3] and power output, which are shown for an example ($T_{well} = 240$ °C) in Figure 6. Figure 7 shows the application of exergy analysis to the single-flash example: it is evident that the re-injection of the hot drain (stream 3) causes a large exergy loss (24,7%), which determines a low exergy efficiency (38%).

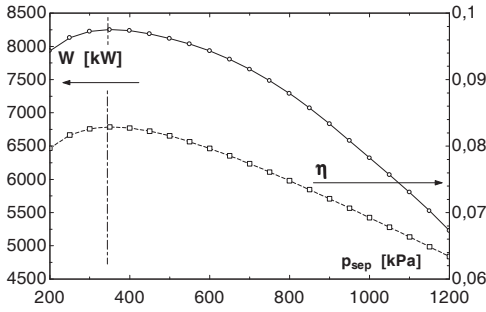

Figure 6: Single-flash; Overall efficiency and power output [3]

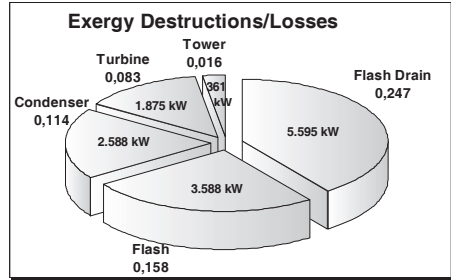

Figure 7: Single-Flash – Exergy balance. Choked well; $p_c = 12,3 \text{ Pa}$; optimized at $p_{sep} = 350 \text{ kPa}$; $\eta_x = 0,38$.

A double-flash arrangement (Figures 8-9) allows a significant improvement in performance. By matching the operating pressures of the two separators, it is possible to achieve – from the same well conditions – a good increase in efficiency (Figure 10) and to reduce substantially the exergy loss connected to reinjection of the hot flash drain (Figure 11).

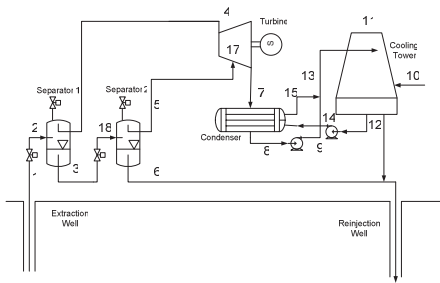

Figure 8: Double-Flash Power Plant Layout

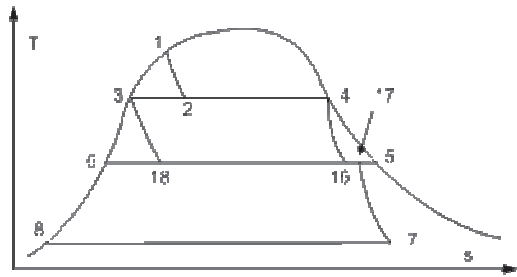

Figure 9: Double-Flash – Thermodynamic Cycle

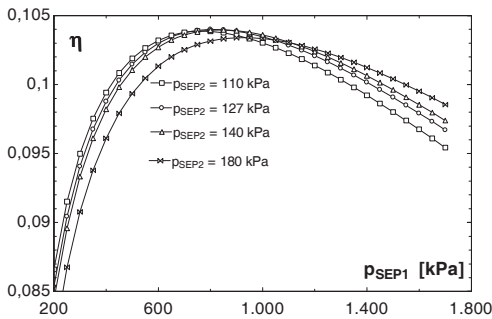

Figure 10: Double-Flash – Cycle efficiency. Choked well; Influence of second flash pressure.

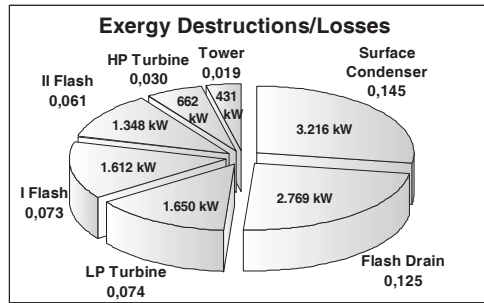

Figure 11: Double-Flash – Exergy balance. Choked well; $p_c = 12,3 \text{ kPa}$; optimized $\eta_x = 0,47$ at $p_{sep1} = 800 \text{ kPa}$; $p_{SEP2} = 127 \text{ kPa}$.

It should be noted that in many cases the temperature of the flash drain cannot be lowered excessively, as the solubility of salts within the geo-fluid decreases with temperatures, and considerable scaling problems are registered in geothermal heat exchangers, separators and piping [1]. This is sometimes a general limit which has been only partly overcome by advances in construction materials and clever design; accordingly, a double-flash (and, equally, a binary cycle

with extensive cooling of the geo-fluid before reinjection) cannot always be applied.

3.2. Dry-steam expansion geothermal plants

A direct-expansion geothermal power plant corresponds to a very simple arrangement (Figure 12). The plant layout is only complicated by the provision for extraction of incondensable gases; the typical arrangement used in Larderello power plants uses a mixing-type condenser, with a large extraction compressor train, with two spray intercoolers using condensate recirculated from the cooling tower (Figure 12).

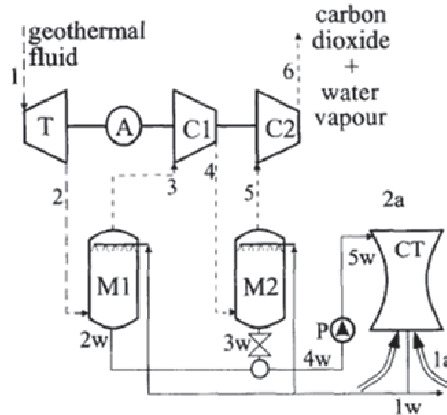

Figure 12: Dry steam power plant diagram [4]

A power plant of the dry steam type achieves typical overall efficiencies of 19%; the exergy efficiency [5] is about 70%, with the distribution of exergy destruction and losses reported in Figure 13. The largest exergy destruction takes place in the turbine (44,8%), followed by the condenser (19,8% destruction + 8,3% loss) and by the first separator M1 (19,8% destruction).

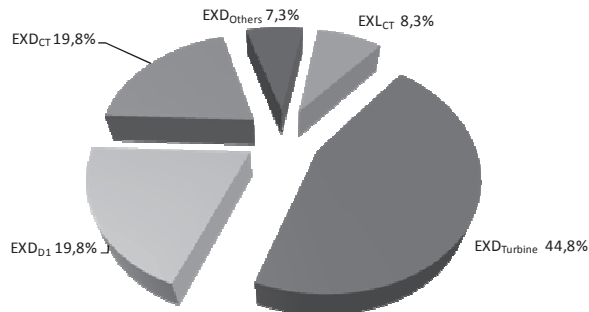

Figure 13: Exergy destruction/loss balance of the dry steam power plant.

A dry-steam geothermal power plant releases all incondensable gases to the atmosphere; usually this is done at the cooling tower, taking advantage of the buoyant wet plume which fosters dispersion of the emissions. However, some pollutants (e.g. Hg) get dispersed in the liquid and this contributes to pollution with the drift of small droplets from the tower. When an emissions treatment system is added [2], abatement levels exceeding 90% have been reported both for H₂S and for Hg (gas phase and water drift).

4. Geothermal power plants of future technology - Binary (ORC)

Binary geothermal power plants do not use the geo-fluid as a working fluid in the cycle; the geo-fluid is only cooled (to the extent allowing free-scaling operation of the heat exchangers), and heat is transferred to a separate working fluid (Figure 14).

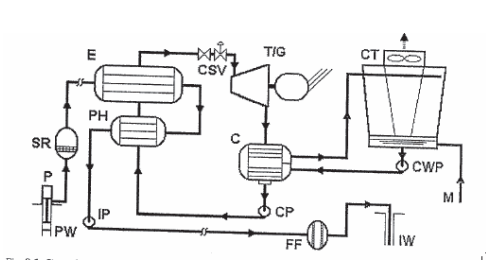

Figure 14: Schematic of a geothermal binary cycle arrangement [1]

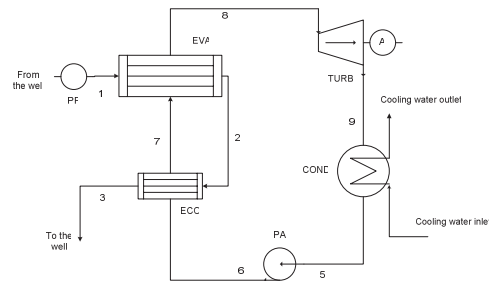

Figure 15: Simple cycle model for binary plant

It can be noticed that any contact of the geo-fluid with the atmospheric environment is avoided; this means that all incondensable and trace pollutants are not emitted, and rather routed back to the geothermal reservoir by means of the re-injection well (IW)¹. This is really a very attractive point for binary cycles. In order to minimize also visual impact, the traditional condenser/cooling tower arrangement (C/CT/CWP) is today usually substituted by a dry air condenser (at the price of some efficiency penalty, as condensation takes place at higher temperature and pressure). Depending on the characteristics of the geothermal resource, the power required for the injection pump (IP) can be relevant.

From the thermodynamics point of view, the binary cycle offers the degree of liberty of selection of the working fluid: this is done mainly matching the choice to the temperature level of the geothermal resource. At present, pure hydrocarbons are the most common choice; engineered fluids (industrial refrigerants, usually HFCs) have been proposed in some cases, with the main advantage of reducing risk of fire (which is a threat when using pure hydrocarbons; in practice perfect sealing is impossible, and all equipment must be oil-refinery safety standard level). Figures 14-15 refers to a sub-critical solution, without regeneration at end of expansion; a typical cycle for isobutane is shown in Figure 16; as it can be seen, the expansion is ending slightly in the superheated region, so that a regenerator would be recommended from the point of view of cycle thermodynamics. However, if the pre-heater is not subject to severe scaling, it makes little sense to send regeneratively-heated working fluid – it is rather important to improve the heat extraction from the geothermal well. As it happens by other Rankine-based heat recovery systems, applied to a single-phase stream with nearly constant heat capacity (e.g. gas-steam combined cycle, exhaust recovery applications of steam cycles), the objective of the plant designer is to maximize power output, that is, the combination of cycle efficiency and efficiency of heat extraction from a source with limited thermal capacity. Typically, a pinch condition occurs (Figure 17), and this influences to a large extent the performance of these plants, which – working on low-to-medium temperatures at the upper level – have limited efficiency.

¹ This is true depending on how much the solubility of dissolved salts and non-condensable gases within the liquid brine is affected by the reduction in temperature. This is anyway a second-order effect with respect to venting to the atmosphere, and can be eventually dealt with by post-processing at heat exchanger level.

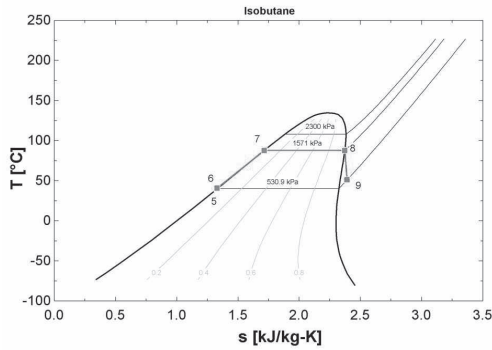

Figure 16: Example of power cycle for isobutane

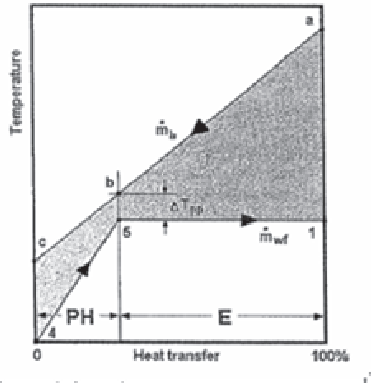

Figure 17: Example of pinch diagram for a geothermal binary plant [1]

Tables 2 and 3 show a comparison between hydrocarbons and HFCs for a small-scale application, comparing three reference cases (a) $m_1=11.7$ kg/s, $T_1=135$ °C (b) $m_1=5$ kg/s, $T_1=135$ °C, (c) $m_1=11.7$ kg/s, $T_1=90$ °C. It is interesting to see that the cycle performance is quite similar; the HFCs allow a possible extension of heat recovery from the geothermal fluid, and the final result for the higher temperature cases ($T_1=135$ °C) is then a larger power output under optimized conditions. The drawbacks of using modern HFCs are a much higher pressurization of the cycle, and eventually a poor quality at end of expansion (with marginal drawbacks on turbine efficiency). When considering the low-resource condition (c) - $T_1=90$ °C – the performance of hydrocarbons and HFCs is very close. It is important to notice that an optimal-work output condition exists for pressure in the case of hydrocarbons (Figure 19), while many HFCs get pushed to the limit condition of critical cycle (Figure 20), from which a reasonable margin should be kept if a sub-critical layout is selected.

Table 2: Binary cycle performance - Hydrocarbons

Fluid	Case	$p_6@ \max$ W_{net} [kPa]	W_{net} [kW]	η_1 [%]	T_3 [°C]
n-butane	a	1157	269	9.3	76
	b	1157	115	9.3	76
	c	659.6	59.3	5	66
n-pentane	a	415	260	9.2	78
	b	415	111	9.2	78
	c	221.9	58.6	5	66
Isobutane	a	1571	278	9.2	74
	b	1571	119	9.2	74
	c	897.5	59.8	4.9	65
End of expansion always superheated ($x_0>1$)					

Table 3: Binary cycle performance - HFCs

Fluid	Case	$p_6 @ \max W_{net}$ [kPa]	W_{net} [kW]	η_I [%]	x_9 [-]	T_3 [°C]
R134a	a	3800	407	9.3	0.87	46
	b	3800	174	9.3	0.87	46
	c	1756	60.5	4.9	0.99	65
R143a	a	2600	152	3.4	0.95	44
	b	2600	65	3.4	0.95	44
	c	3700	86.74	5.3	0.75	57
R152a	a	3017	284.4	9.7	0.93	76
	b	3017	121.3	9.7	0.93	76
	c	1554	59.24	4.9	0.98	66

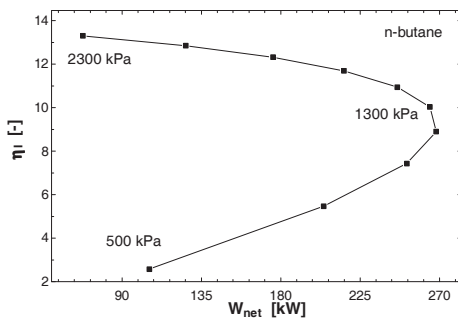

Figure 16: Example of work output optimization vs p_6 for n-butane

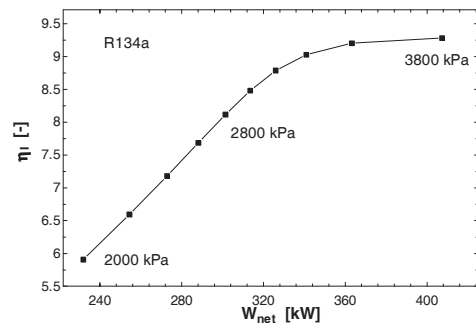

Figure 20: Example of work output trend vs p_6 for R134a

The analysis of performance can be confirmed by running an exergy analysis; Figures 21 and 22 confirm that geothermal binary plants using HFCs are attractive; even if they feature a higher exergy destruction in some components (turbine, condenser), they have much lower EXDs in the geo/working fluid heat transfer equipment (EVA, ECO), and much lower reinjection well exergy loss as the drain can be notably colder. On the whole, the result is a higher exergy efficiency.

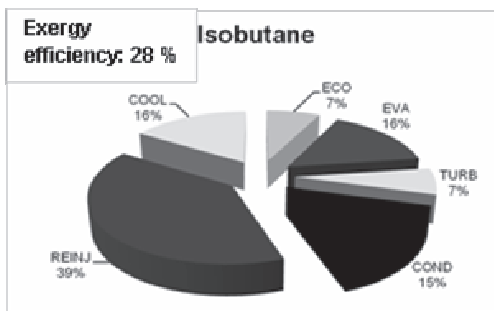

Figure 21: Example of exergy destructions and losses for isobutane

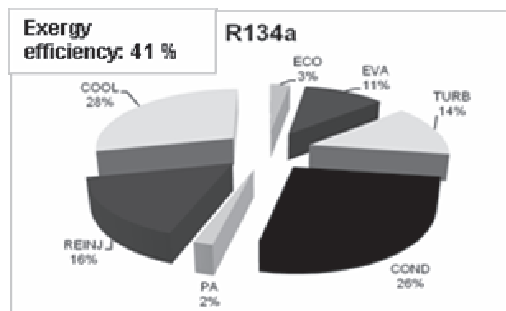

Figure 22: Example of exergy destructions and losses for R134a

The choice of supercritical cycles can be very interesting for improving the thermal capacity matching between geo-fluid and working fluid (Figure 23). However, the technical challenge is

high, also because the thermo-fluid dynamic properties of these fluid in the neighbouring of the critical point are to some extent uncertain. As an alternative, similar performance levels can be obtained by other arrangements, such as pressure-staging the cycle [7], using zeotropic mixtures of hydrocarbons [8], or considering the modern versions of the Kalina cycle [9]; all these solutions call for notable complication of the plant circuit, and are currently justified only for units of relatively large size (> 5 MWe).

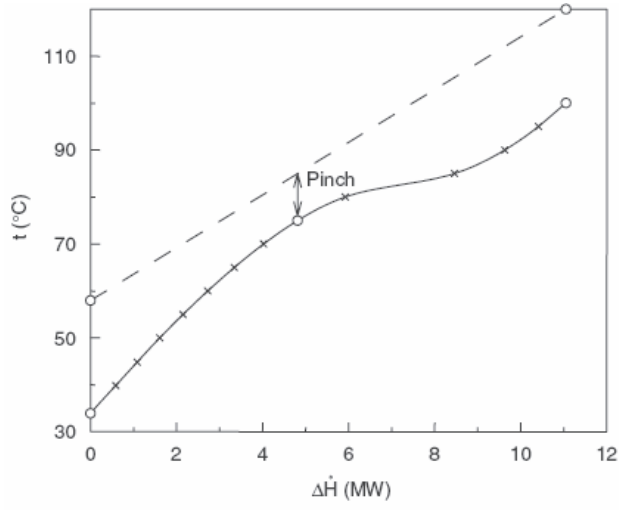

Figure 23: Example of pinch diagram for a supercritical binary solution [6]

5. Combined Heat and Power (CHP) in geothermal energy conversion

Distribution of heat is widespread for utilization of low-temperature geothermal energy; moreover, integration of heat distribution networks is common wherever possible by large geothermal fields (as an example, the Larderello network extends district heating to several small towns, for a total length of the primary circuit exceeding in 2012 the distance of 20 km). It is important to understand how CHP can be matched to binary cycles, which will be the choice of the future in geothermal applications. Considering a binary cycle without regenerator (Figure 24), it is possible to provide the variable heat load demanded by the user (e.g., a district heating network) with a large flexibility, both in terms of heat (kW) and of temperature levels. This opens the way also to distribution of cold (for example, installing remote absorption units fed by heat at the correct seasonal temperature level). In Figure 24, different possibilities of heat extraction from the system are considered: directly from the geothermal fluid (with a preference to increasing heat drainage at low temperature, so that the negative effect of the pinch is attenuated), or from the organic fluid flow rate at turbine discharge (de-super-heater). Figure 25 shows a supercritical cycle with R134a, including super-heating; however, several working fluids have been investigated, in a range of temperatures and heat demand conditions, considering both sub-critical and supercritical ORCs. The flexible arrangement of the heat distribution system includes not only choice of the flow rate to the thermal user, but also that of the temperature level of the geo-source at which diversion of geo-fluid from the “power-only” series ECO/VAP/SH sequence should be started (“Bleed Point”). Figure 26 shows that it is possible to achieve an optimal coupling if both control variables (flow rate and TBP) are carefully adjusted. The configuration can also be adapted to the variable user load by a smart arrangement of by-pass valves.

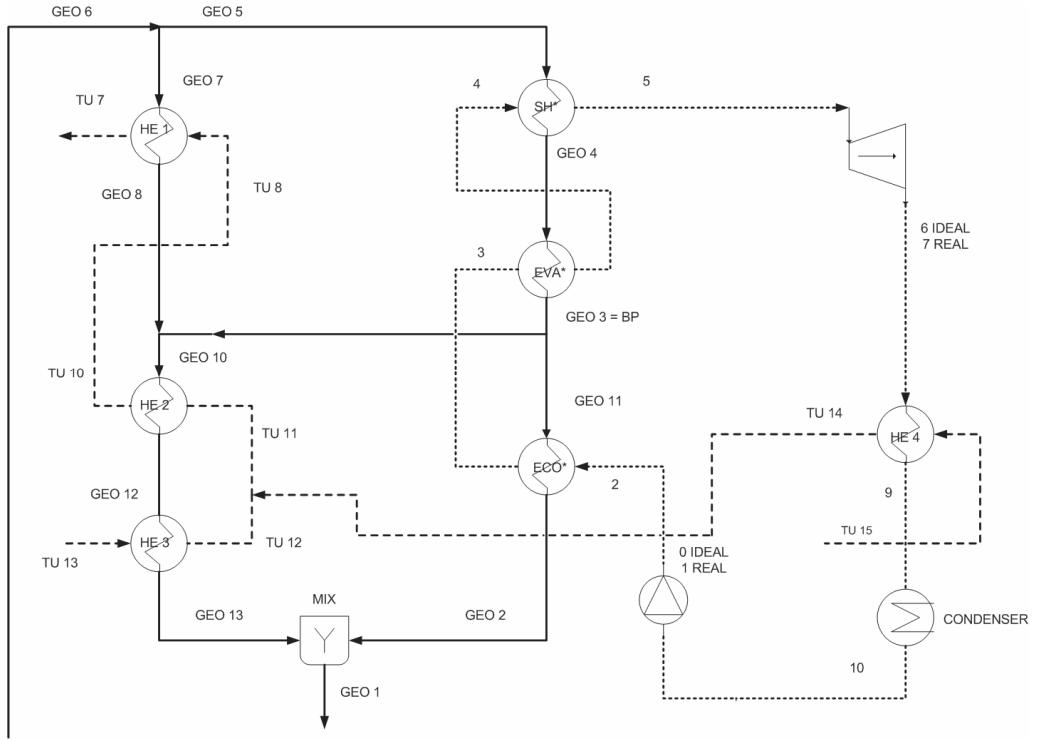

Figure 24: Heat and power combined production system scheme. Continuous line = geofluid circuit, dotted line = TU circuit, dashed line = ORC

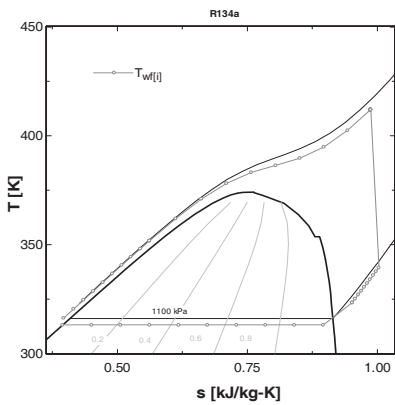

Figure 25: Supercritical ORC cycle

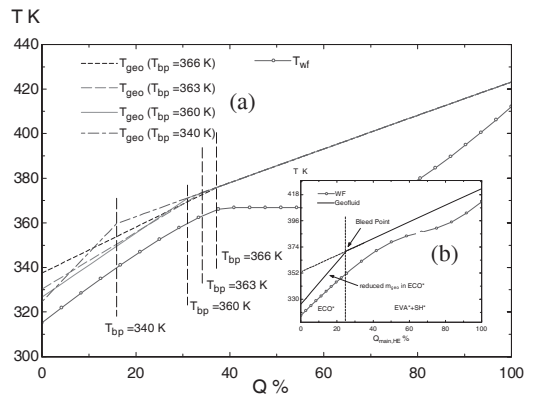

Figure 26: Effect of diverting part of the district heating flow rate to the geo-fluid economizer (a) subcritical (b) supercritical

6. Integrated geothermal and solar energy conversion systems

Integration between solar and geothermal energy conversion can be highly recommended. Different systems can be proposed, depending on the site characteristics (relative availability of geothermal and solar energy; type of reference system). Figure 27 [7] shows the proposal for

simple integration for a small-scale CHP plant, with a rated power output of 50 kW_e and the capability of providing 240-380 kW of thermal power. For all cases the condenser temperature was set at 45°C, which is compatible with a small local network for low-temperature heating of buildings. The solar field is assembled with Evacuated Tubular Collectors (ETC), which can reach without concentration (or with the help of non-tracking reflectors) the design temperature value of 420K. Pressurized water or a synthetic heat transfer fluid can be used at these moderate temperatures, and heat is transferred to the working fluid of the ORC through a simple arrangement (Economizer-Evaporator-Superheater) with recirculation loop at the evaporator. It is important to notice that this system is proposed to exploit a number of non-productive wells which are already present in the Tuscan geothermal region; these wells have demonstrated to be non-economic for connection to the geo-fluid distribution grid, due to geographical location, reduced flow rate and enthalpy conditions. However, an exploration well has been drilled and a reinjection well can be available at reasonable distance, allowing conservative use of the geothermal reservoir. For these reasons, an external geothermal heater is proposed, which is simpler and easier for maintenance with respect to a borehole heat exchanger.

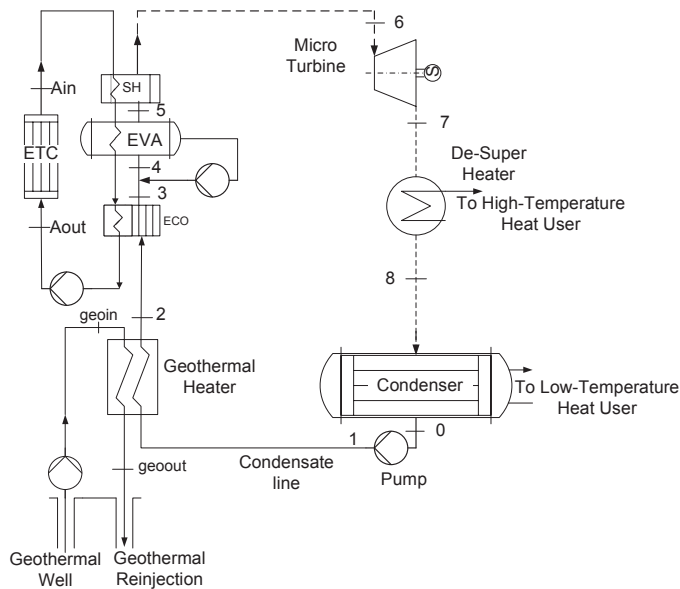

Figure 27: Integration between geothermal and solar – small CHP system

Table 4 presents the reference data and the calculated results for three different working fluids, for the design conditions set at June 15th in the Tuscan geothermal region. From many points of view, R245fa appears the most attractive choice, because of several reasons (higher cycle efficiency; small-size de-super-heater; smaller solar collector surface and investment costs); on the other hand, it is also the solution with the lowest input from geothermal resource (<24% input heat).

Here again, it is possible to perform an exergy analysis to understand the major contributions to exergy destruction and loss during the conversion process. The results are shown in Figure 28. It is clear that the performance is heavily influenced by that of the solar collector, with two relevant contributions: heat transfer exergy destruction (50-54%) and exergy loss (collector heat loss; about 16,5%). The energy conversion equipment represents a number of minor exergy destructions, all below 2,5% (Economizer heat transfer exergy destruction, R245fa). The solution with R245fa is finally favored by the smaller surface of the solar field.

Integration between geothermal and solar is highly recommended also to face other problems, that is: a) long-time decay of the geothermal resource b) seasonal performance of binary geothermal plants equipped with air condensers. These problem have been reported in some

relevant geothermal fields [11] and currently re-powering of the binary cycle units with a large CPC solar field, arranged in a geothermal pre-heating scheme similar to that shown in Figure 27 is in progress.

Table 4: Small solar/geothermal CHP system – comparison of performance with different working fluids

Fluid	R134a	R236fa	R245fa
Critical Pressure [bar]	40,59	32	36,5
Critical Temperature [K]	374	398	427
Upper cycle pressure pressure p_1 [bar]	38	29,3	31
Condenser pressure p_0 [bar]	11,6	5	2,92
Geothermal reinjection temperature [K]	321	323	323
Superheating $DT = T_6 - T_5$ [K]	49	26	1,3
Temperature at De-superheater inlet T_8 [K]	371	366	335
Water temperature at De-superheater outlet [K]	367	359,5	330
Organic fluid flow rate [kg/s]	1,77	1,84	1,33
Geothermal fluid flow rate [kg/s]	0,63	0,59	0,43
Solar collector flow rate [kg/s]	1,1	1,16	3,45
Collectors effective area [m ²]	411	356	305
System efficiency [%]	9,1	9,78	13
Cycle efficiency [%]	10,5	11,3	15,1
Exergy efficiency [%]	22,7	23,3	25,0
Geothermal power input Q_{geo} [kW]	111	98,5	72,4
Solar power input Q_{solar} [kW]	316	273,5	235
De-superheater recovered heat [kW]	102	82,5	23
Condenser recovered heat [kW]	280	247	237,5
Pump Power W_p [kW]	5,1	7,8	3,6
$Q_{geo} / (Q_{geo} + Q_{solar})$ [%]	26	26,5	23,6
$W_p / (W_p + W_D)$ [%]	10,3	16	7,3
Geothermal Heat Exchanger surface [m ²]	535	183,5	69
Economizer surface [m ²]	35,5	29,6	14,2
Evaporator surface [m ²]	37,4	32,4	58
Superheater surface [m ²]	40,6	34,2	4

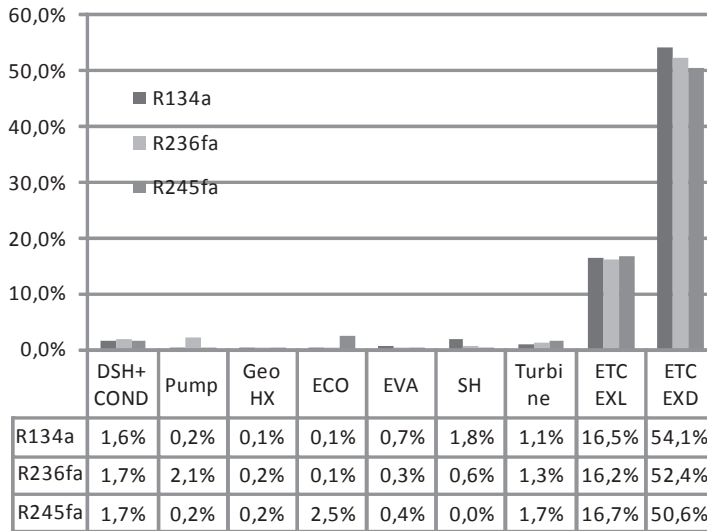

Figure 28: Small solar/geothermal CHP system - Distribution of exergy destructions and loss for three different working fluids.

7. Concluding remarks

Specific results for the reference application cases have been shown through the different sections of this contribution, whose purpose is to give a perspective view of activities carried out during several years in the field of sustainable development of geothermal energy.

Geothermal energy is becoming more and more important in many countries, seeking sustainable energy resources capable of replacing effectively the use of fossil fuels. Modern solutions with binary (ORC) power plants offer a substantial appeal from the point of view of sustainable development, proposing a new, clean and socially acceptable image of geothermal energy systems.

The benefits can be particularly attractive if combined heat and power or tri-generation of electricity/heat/cooling can be proposed. In some cases this can be done with small CHP units, requiring a small local sub-grid.

Integration of solar and geothermal works very well and can be absolutely recommended, as well as other advanced solutions and taking care to develop from start clever arrangements for the flexible distribution of electricity, heat and cooling meeting the user demand and the market price fluctuations. Correct control of the system with the objective of meeting the demand and maximizing profit is essential for the success of these systems, which require a relevant investment of capital but can guarantee a reliable and trouble-free operation with limited costs of O&M.

Exergy analysis can be applied systematically to the design, optimization and off-design prediction of these systems. It allows a correct comparison of different options, a true evaluation of the critical components, and the introduction of effective ideas with special reference to flexible system design, meeting variable heat/cooling loads in CHP applications, and integration with solar energy conversion systems. The use of exergy in these studies is being extended to thermo-economics and exergo-economics (coupled to Life Cycle Analysis) in order to assess the transformation of economic flows across the conversion system, and to evaluate and compare the sustainability with respect to the environment.

Acknowledgements

Activities relating this research have been co-funded by Regione Toscana, network project “BT-GEO H&P: - Sistemi di Generazione Distribuita di Energia Elettrica e Termica da Fonti

Geotermiche”, which sustained the topic of development of small CHP systems using geothermal energy by means of a total of 8 years manpower at post-graduate/post-doc level, using European Social Fund (FSE) resources.

Invitation to the CPOTE Conference within the RECENT Research Center activities is gratefully acknowledged.

References

- [1] Di Pippo, R., *Geothermal Power Plants*. Elsevier, 2007.
- [2] Baldacci, A., Mannari, M., Sansone, F., Greening of geothermal Power: *An Innovative Technology for Abatement of Hydrogen Sulphide and Mercury Emissions*. Proceedings World Geothermal Congress, Antalya, 2005.
- [3] Coviello, M., Manfrida, G., Exergy Analysis of single and double-flash Geothermal power plants. ECOS 2010, Foz de Iguazu, Brazil.
- [4] Bettagli N., Bidini G., Larderello-Farinello-ValleSecolo geothermal area: exergy analysis of the transportation network and of the electric power plants. *Geothermics* 1996; 25 (1): 3-16.
- [5] Tempesti, D., Manfrida, G. Madiari, L., Exergy and energy analysis of a dry-steam power plant equipped with a hella condenser, ECOS 2011, Novi Sad, 2011.
- [6] Saleh, B., Koglbauer, G., Wendland, M., Fischer, J., *Working fluids for low-temperature organic Rankine cycles*, *Energy*, 32, 2007, 1210-1221.
- [7] Kanoglu, M., exergy analysis of a dual-level binary geothermal unit, *Geothermics*, 31, 2002, 709-724.
- [8] Angelino, G., Colonna di Paliano, P., *Multi-component working fluids for organic Rankine cycles*, *Energy*, 23, 6, 1998, 449-463.
- [9] KALEX LLC, Kalina cycle power systems for geothermal applications, <http://kalexsystems.com/Kalex%20Geothermal%20Brochure%2010-10.pdf>
- [10] Tempesti, D., Manfrida, G., "Thermodynamic analysis of two micro CHP systems operating with geothermal and solar energy", *Applied Energy*, 97, September 2012, 609–617.
- [11] ENEL Ricerca SpA, Private communication.