



UNIVERSITÀ
DEGLI STUDI
FIRENZE

FLORE

Repository istituzionale dell'Università degli Studi di Firenze

Formation and quality of wood surfaces processed at various grain angles - Douglas Fir and Oak

Questa è la Versione finale referata (Post print/Accepted manuscript) della seguente pubblicazione:

Original Citation:

Formation and quality of wood surfaces processed at various grain angles - Douglas Fir and Oak / Giacomo Goli; Laurent Bléront; Rémy Marchal; Luca Uzielli; Martino Negri. - STAMPA. - (2002), pp. 91-98. (Wood Structure and properties '02 Bystra, Slovakia 01-03 September 2002).

Availability:

The webpage <https://hdl.handle.net/2158/831141> of the repository was last updated on 2016-11-16T17:25:14Z

Publisher:

Arbora Publishers

Terms of use:

Open Access

La pubblicazione è resa disponibile sotto le norme e i termini della licenza di deposito, secondo quanto stabilito dalla Policy per l'accesso aperto dell'Università degli Studi di Firenze (<https://www.sba.unifi.it/upload/policy-oa-2016-1.pdf>)

Publisher copyright claim:

La data sopra indicata si riferisce all'ultimo aggiornamento della scheda del Repository FloRe - The above-mentioned date refers to the last update of the record in the Institutional Repository FloRe

(Article begins on next page)

WOOD STRUCTURE AND PROPERTIES '02

Jozef KÚDELA
&
Stanislav KURJATKO
editors

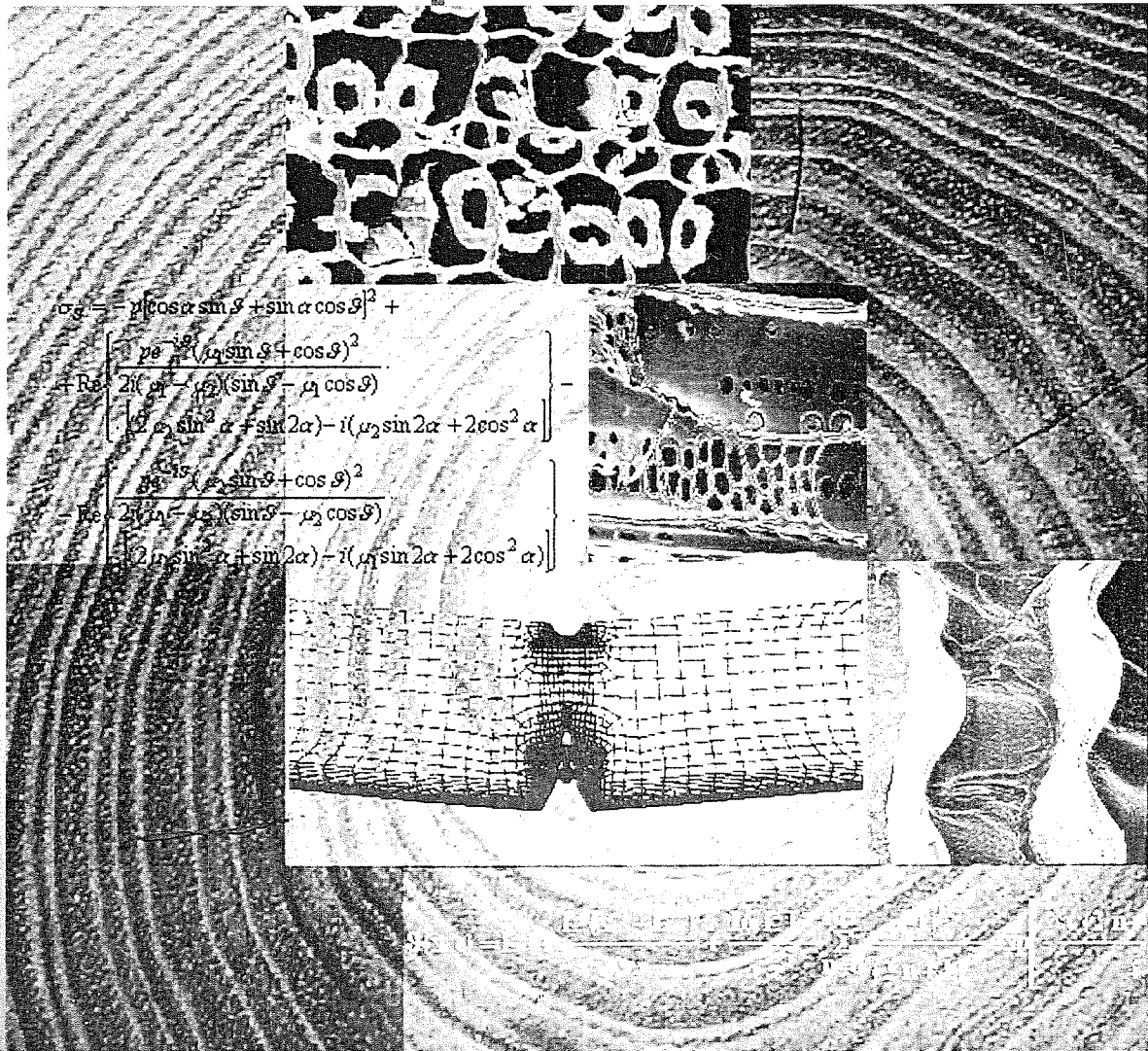

Arbora
Publishers

WOOD STRUCTURE
AND
PROPERTIES '02

Jozef KÚDELA
&
Stanislav KURJATKO
editors

Arbora
Publishers

Proceedings of the 4th IUFRO Symposium "Wood Structure and Properties '02" held on September 1–3, 2002 in Bystrá, Slovakia and organized jointly by the Faculty of Wood Sciences and Technology of the Technical University in Zvolen and the IUFRO Research Group 5.01.00 "Wood Quality".

Organizers:

Faculty of Wood Sciences and Technology, Technical University in Zvolen, Slovakia
IUFRO Research Group 5.01.00 "Wood Quality"

© Jozef Kúdela & Stanislav Kurjatko, editors, 2002

© Arbora Publishers, Zvolen, Slovakia, 2002

Printing: Litomont, s.r.o., Banská Bystrica, Slovakia

Technical editor: Antónia Malenká

Cover design: Miroslava Mamoňová

Number of pages: 221

The manuscripts have been peer-reviewed by the editors and anonymous reviewers.

ISBN 80–967088–9–9

CONTENTS

WASHUSEN, R. & EVANS, R.: The measurement of cellulose crystallite width by X-ray diffraction on SilviScan-2 and its possible application in eucalypt and acacia species	7
KAČÍKOVÁ, D., CICHOCKA, M. & KAČÍK, F.: Macromolecular characteristics of lignins of selected archaeological wood species	13
PRADZYŃSKI, W., WALISZEWSKA, B. & CICHOCKA, M.: Research on the chemical composition of bushy willows and their possible application in forestry	17
WALISZEWSKA, B.: Chemical composition of 2- and 4-year-old samples of willow varieties <i>Salix viminalis Stipularis</i> and <i>Salix viminalis Reifenwardii</i>	21
FABISIAK, E. & MOLIŃSKI, W.: Variability of the wood basic density and length of tracheids in 45-year larch-fir stand (<i>Larix decidua</i> Mill.)	25
BALODE, V., ALKSNE, A., DOLACIS, J. & HROLS, J.: Anatomical structure of wood of Norway spruce (<i>Picea abies</i> L. Karst.) in forests of western Latvia	29
ŠĶĒLE, K., ALKSNE, A., CĪRULE, D. & HROLS, J.: Anatomical structure and physical properties of latvian pine (<i>Pinus sylvestris</i> L.) wood	33
RAČKO, V. & ČUNDERLÍK, I.: The ripewood and false heartwood proportions at different beech stem levels	39
LIPINS, L. & SARMULIS Z.: Investigations on dimensional and qualitative variation of pine (<i>Pinus sylvestris</i>) trunk-wood lengthwise the stem	43
KOLLÁRIKOVÁ, R.: Structure analysis of dormant eyes of black alder	47
MAMOŇOVÁ, M., LAUROVÁ, M. & NEMČOKOVÁ, V.: Analysis of structure of beech wood subjected to hydrothermic treatment	51
KURJATKO, S., SOLÁR, R., MAMOŇOVÁ, M. & HUDEC, J.: Selected properties of beech wood biodegraded by white-rot fungi	57
ČUNDERLÍK, I. & HUDEC, J.: Axial permeability of normal and tension beech wood	63
HUDEC, J.: Mutual comparison of axial permeability of beech stems for water amongst selected localities from surroundings of Zvolen	69
BABIŃSKI, L., KÚDELA, J. & KOKOCIŃSKI, W.: Archaeological softwood. Part I. Structure and properties	73
BABIŃSKI, L., KÚDELA, J. & KOKOCIŃSKI, W.: Archaeological softwood. Part 2. Microscopic analysis after dimensional stabilisation various impregnating materials.	81
GARDNER, J. D.: Wood surface properties	87
GOLI, G., BLERON, L., MARCHAL, R., UZIELLI, L. & NEGRI, M.: Formation and quality of wood surfaces processed at various grain angles – Douglas fir and oak	91
BABIAK, M., MAMOŇOVÁ, M., HRČKA, R. & MAMOŇ, M.: The utilization of digital technique for objective determination of the color of wood	99
MITSUI, K., MURATA, A., TSUCHIKAWA, S. & KOHARA, M.: Changes in the color of light-irradiated wood with heat treatment: Print of photograph onto wood	105
TOLVAJ, L., VARGA, D. & KOMÁN, S.: Colour modification of dried black locust and beech woods by steaming	109
DOLACIS, J., HROLS, J., CĪRULE, D., SKUDITIS, J., ZIVERTS, A. & KURJATKO, S.: Investigation of the optical characteristics of birch wood depending on the species and hydrothermal treatment conditions	115

KISKA, P.: Acoustic characteristics of resonance spruce wood measured by modal analysis method	121
ROSCA, I., PÜHRINGER, R., SCHMIDT, H. & TANCZOS, I.: New aspects in studying and applications of ammonia treatment of softwood	127
DOLACIS, J., TOMSONS, E., HROLS, J. & CIRULE, D.: Dependence of heat value on moisture content for chips, sawdust pellets and granules for different wood species	133
ŠTEFKA, V., BABIAK, M., NAŠČÁK, L. & MIKULA, M.: Mat temperature during the pressing of particleboards in press with cooling	139
UGOLEV, B. N., SKURATOV, N. V. & GORBACHEVA, G. A.: The influence of deformation prehistory upon the "memory effect" of wood	145
DUBOVSKÝ, J.: Sensing and evaluation of stress-strain diagram of spruce wood at tension loading ..	151
PUSHINSKIS, V., PRIEDKALNS, G., DOLACIS, J. & HROLS, J.: Selected mechanical properties of norway spruce wood in Latvia	157
MÜLLER, U., JOŠČÁK, T. & TEISCHINGER, A.: Strength loss of dried and re-moistened spruce wood compared to native wet wood	161
JOŠČÁK, T., BABIAK, M., MÜLLER, U. & TEISCHINGER, A.: Increased mechanical properties of spruce wood dried in nitrogen atmosphere compared to conventional kiln drying	165
BODNÁR, F.: Influence of some wood characteristics on tenseness around a stress concentrator..	169
BUCHAR, J., SMRŽ, J. & SEVERA, L.: Behaviour of notched spruce beams under dynamic loading	173
SONDEREGGER, W. & NIEMZ, P.: The influence of compression failures on the bending, impact and tensile strengths of spruce wood and the evaluation of non-destructive methods for an early failure detection	177
HAIDER, A., RÄTZSCH, M. & MÜLLER, U.: Qualitative determination of plasticization and plasticity of wood-splinters	185
TIRALOVÁ, Z. & REINPRECHT, L.: Bending strength and durability of wood modified with polyacrylates	189
KRÁL, Š. & KURJATKO, S.: The influence of thermo-mechanical loading on deformation of spruce wood loaded in buckling	195
KÚDELA, J.: Stresses in columns eccentrically loaded in buckling indicated by means of reflection photoelasticimetry	201
HEIKE SEUBERT, H. & SONDEREGGER, W.: Microscopic investigation into compression failures in trees damaged by heavy storms	211
MIŠÍKOVÁ, O.: Necrosis of beech trees – macroscopic symptoms of necrotic wounds	213
VESELOVSKÝ, J. & ČUNDERLÍK, I.: Georges Jacob`s seating furniture – material and construction	215
POPOVIĆ, Z. & LAVADINOVIĆ, V.: Main physical and mechanical properties of wood of different douglas-fir provenances	217
MIRIĆ, M. & POPOVIĆ, Z.: Changing of wood structure of oak due to attack of stereoid fungi ..	219
MARAVIĆ, M., MIRIĆ, M. & POPOVIĆ, Z.: Changes of mechanical properties of Oak wood attacked by fungus <i>Laetiporus sulphureus</i> (Bull. ex Fr.) Murrill	221

FORMATION AND QUALITY OF WOOD SURFACES PROCESSED AT VARIOUS GRAIN ANGLES – DOUGLAS FIR AND OAK

GIACOMO GOLI¹, LAURENT BLERON², REMY MARCHAL², LUCA UZIELLI¹ & MARTINO NEGRI³

¹DISTAF, University of Florence, 50141 Florence, Italy – giacomo.goli@unifi.it

²ENSAM-LABOMAP, 71250 Cluny, France – laurent.bleron@cluny.ensam.fr - remy.marchal@cluny.ensam.fr

³ITL/CNR, 38010 S. Michele a/A, Italy – martino.negri@itl.tn.cnr.it

ABSTRACT

In the framework of a research dealing with formation and quality of machined wood surfaces we carried tests on Douglas fir and oak. We studied the mechanisms of wood surface formation in processing the wood at different grain angles, against the grain direction, along the grain direction, by up-milling and down-milling. Surfaces were analysed by macroscopic analysis, observed with SEM, and also subjected to profile analysis.

Keywords: surface quality, surface formation, grain angle, profile measurements, Douglas fir, oak.

INTRODUCTION

The suitability to be processed is different for different wood species, in dependence on the characteristics of the individual species. In order to understand the process of surface formation we performed tests on Douglas fir from French plantation and on French oak, processed at different grain angles. While European Douglas fir is a species well known with a considerable difference between early- and late-wood, oak is a species with more homogeneous wood structure. Much effort has been exerted in the late years to understand suitability of many different species to be processed. This work has been undertaken in order to clarify the mechanisms that characterise the chip formation and the surface formation in wood machining process, as a function of the angle between the grain and the working directions. In fact, the final surface quality is influenced by many "external" factors, such as the tool setting or machine setting, and by some factors "internal" to the wood, such as moisture content, and mainly grain angle. The available technologies can adjust the external factors so that the best quality can be obtained, compatible with the internal factors. If internal factors are not optimum for processing, technologies might improve the final quality, but this need not to mean a good quality. To summarise this concept we may say that a body can be more effectively processed by adjusting the external factors, only if the internal factors, and mainly the grain orientation, allow it. Therefore our research has been focussed on analysis and interpretation of the process of surface formation. We also measured cutting forces and grading surface quality.

MATERIAL AND METHODS

The machining process

In order to define the best setting of the processing parameters, some preliminary tests were performed on

Douglas fir (*Pseudotsuga menziesii* Franco var. *menziesii*) and oak (*Quercus robur* L.) at different grain angles, at different depths of cut, feeding speeds and revolutions per minute. We tried to set parameters in such a way as to obtain fast processing with a good final quality. We performed many tests with "up" and "down-milling" to understand typical defects for each technique and to find which of them is more promising for a good final quality. After several preliminary examinations the set-up reported in Table 1 has been chosen as the more suitable for our tests.

The size of the specimens we determined in such a way as to enable us the most effective measurements of cutting forces (not analysed in this paper) and to provide surfaces large enough for the analysis. The cutting depth was 0.5 mm because with larger depths the surface quality didn't change significantly, and with this small value the successive surfaces were very close to each other. The wood was cut only by the lateral knives, to avoid undesired disturbances. The tested specimen was fastened by two screws; the metal plate compressing the wood was fixed by means of a vacuum system. The weight of the whole system ensures its stability, and the vacuum system held it firmly against the machine table. The grain angle (ξ) was changing from 0 to 90° by increments of 10°. The "-before the angle value means that the surface was processed against the grain direction. The presence of "0°" and "-0°" and of "90°" and "-90°" means that the same surface has been processed after being tilted at 180°. This processing in the two opposite directions, was performed in order to verify if the same final quality and the same profile were obtained for 0°/-0° and 90°/-90°, respectively, if the grain direction was really perpendicular (for grain angle -90° and 90°) or parallel (for -0° and 0°) to the processing plane. Moreover this was also an indication, although limited, of the repeatability of the test.

We used specimens with annual rings oriented so that the radial plane is processed, in order to avoid the alternating of early- and late-wood; consequently the surface quality results from processing early- and late-wood separately, with no interaction between the two (Figures 1 and 2).

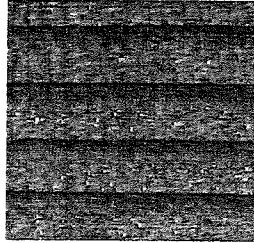

Figure 1 Radial surface

Observation with SEM

The machined surfaces were observed with SEM (a Joel Scanning Electron Microscope), in a low-vacuum mode, with no previous treatment of samples.

Profile measurement

Profiles were analysed by means of a profile measurement device, in order to give an objective comparison between the processed surfaces. The quantitative results can easily be plotted; moreover, the current available standards (such as the ASTM standard D-1666-87, which is based on a limited number of visually detectable defects) do not provide methods for evaluating machining defects on surfaces processed with down-milling technique. The measurements set-up is described in Table 2.

Table 1 Experiment set-up

Fixed Parameter (imposed by the material)	Variable
Milling machine: 3 axes CNC router	Cutting length: 80 mm
Wood species: Oak, Douglas fir	Cutting height: 30 mm
Moisture content: Oak : 12,5 % ~ Douglas fir : 11 % ~	Cutting depth: 0,5 mm
Average specific gravity: Oak: 0,66 g/cm ³ Douglas fir: 0,45 g/cm ³	Feeding speed: 5 m/min
Rake angle (α): 20°	Rotation speed: 13867 Rev./min
Clearance angle (β): 15°	Cutting technique: down milling up milling
Knives mounted on the cutting head: 2	Processing: along grain direction against grain direction
Knife material: tungsten carbide screwed inserts (HW)	
Cutting head diameter: 40 mm	

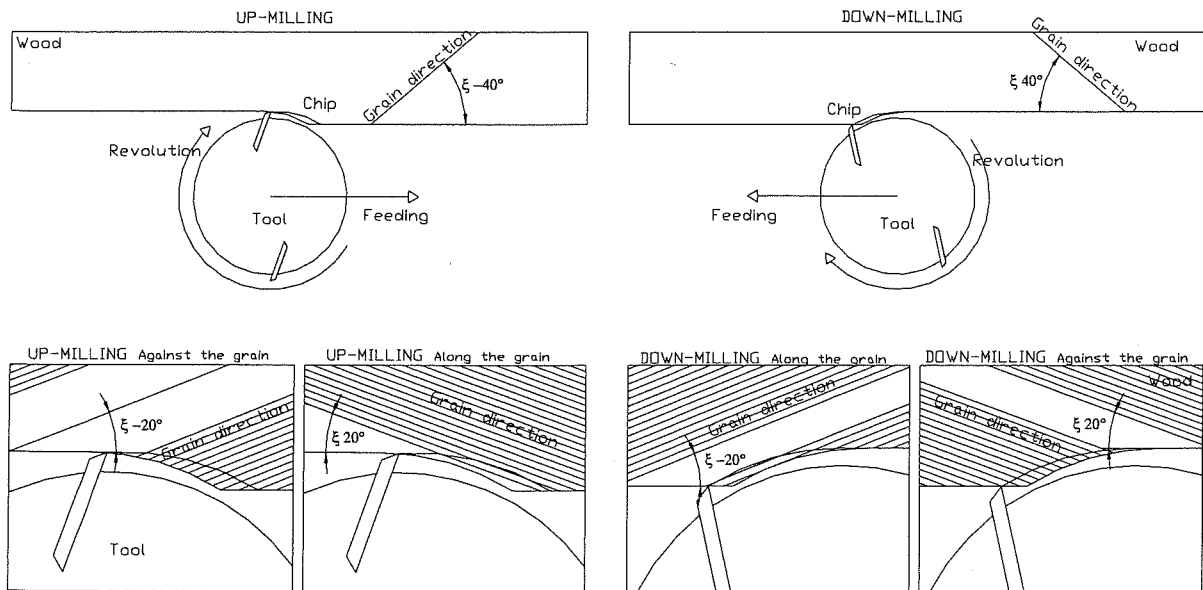

Figure 2 The four main experimental conditions

Table 2 Set-up of the system of profile measurement

Device	2D Profilometer (Surface Profiling Instrument)
Sensor	Stylus
Measurement type	2D
Stylus tip radius	10 μm
Transducer's range	+/- 5 mm
Measuring length	25 mm
Measuring speed	1 mm/sec
Shape filter	Linear
Acquired parameters	Pa, Pt

Pa is the integral of the profile divided by the profile length and Pt is the difference between the highest peak and the deepest depression in the profile length.

RESULTS

Dependence of the surface quality on grain angle and on different cutting techniques (up- and down-milling) is discussed in details in this paper. Surface quality was examined and compared by means of macroscopic, SEM, and profile analysis. By macroscopic analysis we just identified main defects arising on the surfaces processed by down-milling technique; SEM analysis allowed us to have a distinct view on the defects caused by machining and the differences between their occurrence and character in early- and late-wood; profile analysis allowed an objective evaluation of the final quality of processed surfaces, expressed as a function of the examined parameters.

Macroscopic analysis

Figures 3 and 4 show some macro photographs of the main defect (which could provisionally be named "tilted grain") arising in processing by down-milling technique; this severe defect is characteristic for the surfaces processed against the grain, in the range from 30° to 80°, for both the examined species. In facts during the cutting process, the wood tissues are compressed and subsequently tilted during the tool revolution. The tilting "axis" is under the surface, and the defect affects the whole surface (only the late-wood in Douglas fir, all wood in oak), resulting in a very bad final quality of the processed wood.

Analysis with SEM

All the SEM images were taken at a 50fold enlargement.

Douglas fir

Douglas fir frequently shows defects arising from the great difference (mostly in density) between early- and late-wood: the two types of wood have a very different mechanical behaviour.

Up-milling

Up-milling technique is the "common" technique for solid wood processing. Many of the defects discussed by ASTM D-1666-87 occur on these surfaces. In the case of processing along the grain we obtained a good quality at processing angles up to 20°, even if a great difference between early- and

late-wood was obvious; whereas the late-wood always showed a fairly good surface quality. The following behaviour (Figure 5) can be observed in the early-wood: at the processing angle under 60° some wood particles were torn away forming a conchoidal fracture (i.e. a cavity having a conchoidal shape), whereas at angles ranging from 70° to 90° wood particles were torn away, without forming a conchoidal fracture. This behaviour might be explained by analysing the compressive component of the knife edge at the beginning of the cut, in relation to the slipping planes of the wood. However, this subject is too complex to be discussed here.

In the case of wood processed against the grain, the wood particles tend to be torn away. For small angles the occurrence of torn grain is limited, and fuzzy grain is formed in the early-wood. With increasing grain angle wood particles are torn away up to -80°/-90° where the early-wood is completely torn away, whereas the late-wood still remains in good state.

Down-milling

This technique is not used in processing solid wood; in this case, as we can easily see comparing Figures 6 & 8, the final quality is worse than the quality obtained by up-milling. In processing against the grain we observe the formation of the above mentioned "tilted grain", not included in ASTM D-1666-87, that considerably affects the surface quality (see Figures 3 & 4). The quality of wood processed along the grain is not far from quality obtained by up-milling, because at low angles the fractures in the early wood begin to arise earlier compared to up-milling (since 10°). On the other hand, at high grain angles the compression before the cut causes tearing of parts of early wood with smaller dimensions compared to up-milling. Anyway, the quality is still very poor (Figure 7).

In the case of processing against the grain the "tilted grain" occurs, depending on the fact that the wood is compressed before cutting, and then the cut is more difficult. Large wood particles are broken deeply under the surface and tilted, causing a very bad final quality (Figure 8) of the processed wood. This defect occurs from -30° to -80°. For -10° and -20° fuzzy grains persist, even if their formation and aspect are different compared to the up-milling process.

Oak

Oak has only a small density variation within the rings; for this reason we deal with a more homogeneous behaviour of wood. The different density plays anyway an important role inside the ring, and the presence of large vessels sometimes seems to be a problem. Also on oak we processed the radial surface, in order to avoid interactions between early- and late-wood zones. As for Douglas fir, great differences arise in processing in different ways; here-after the main defects are reported and briefly discussed.



Figure 3 Douglas fir processed using down-milling technique ($\xi = -40^\circ$)

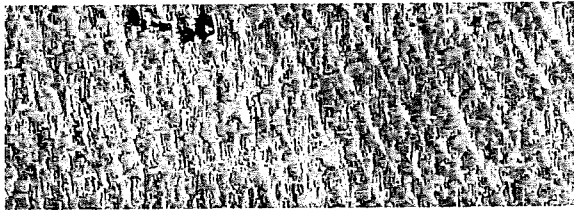

Figure 4 Oak processed using down-milling technique ($\xi = -60^\circ$)

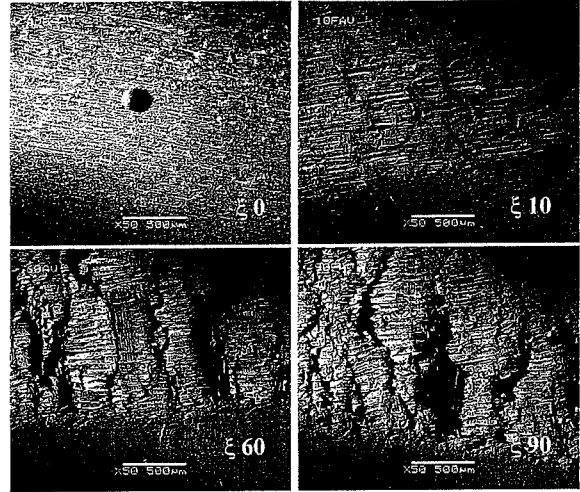

Figure 7 Douglas fir processed by down-milling, along the grain

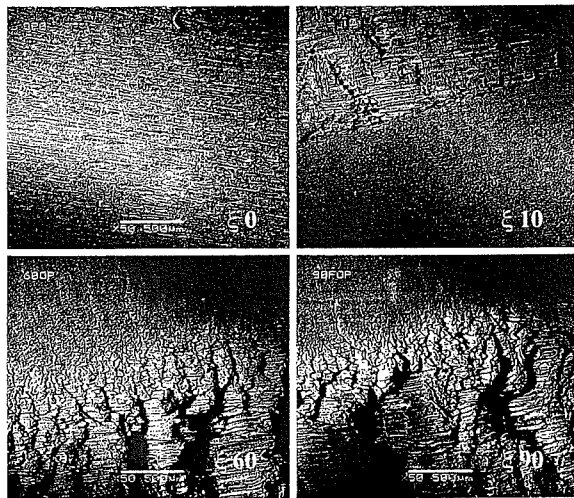

Figure 5 Douglas fir processed by up-milling, along the grain

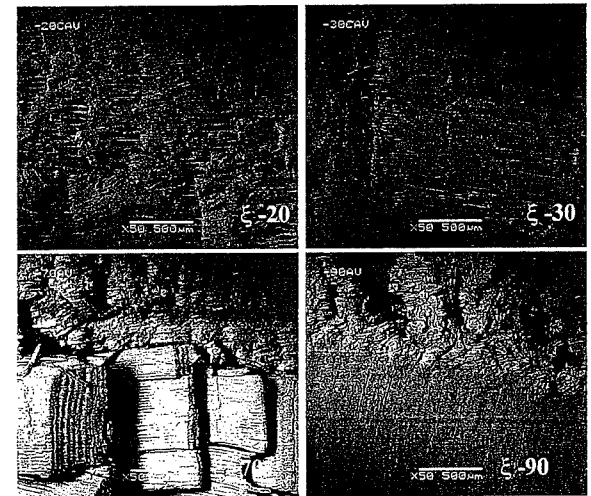

Figure 8 Douglas fir processed by down-milling, against the grain

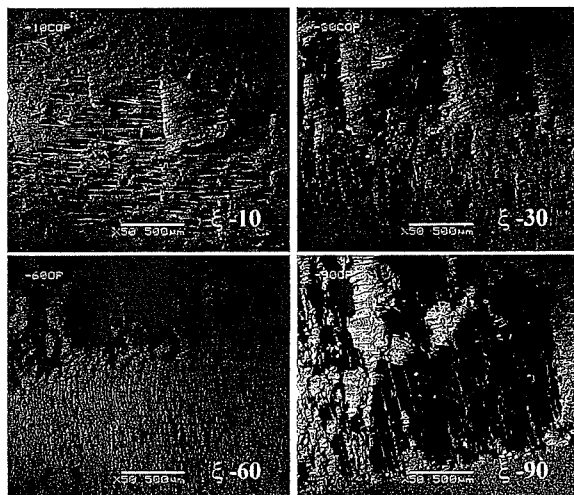

Figure 6 Douglas fir processed by up-milling, against the grain

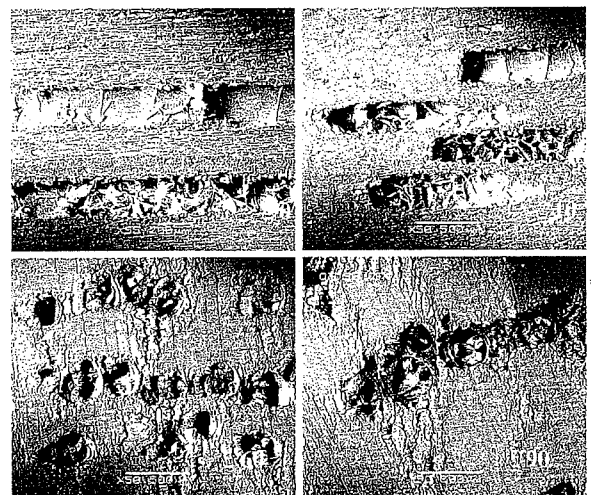

Figure 9 Oak processed by up-milling, along the grain

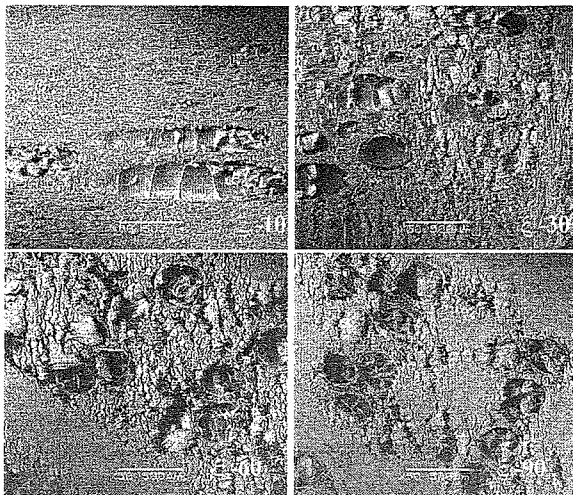

Figure 10 Oak processed by up-milling against the grain

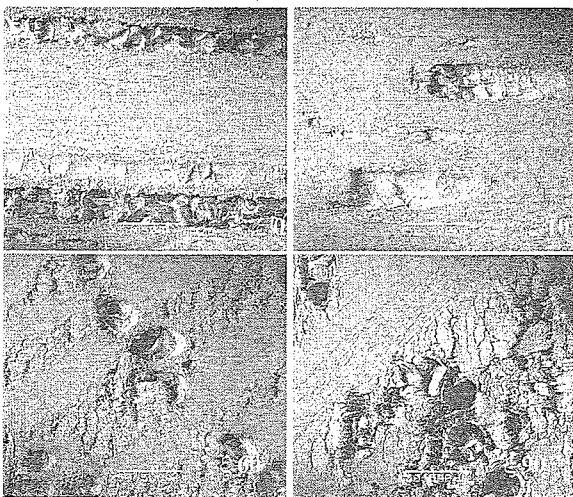

Figure 11 Oak processed by down-milling, along the grain

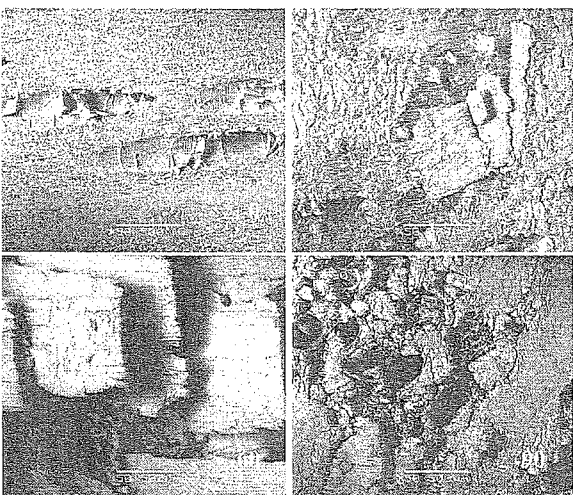

Figure 12 Oak processed by down-milling, against the grain

Up-milling

As it is evident from Figure 9 the aspect is very different from Douglas fir but the role of the density is well visible. Processing along the grain often carries a good quality. For narrow angles ($10^\circ/20^\circ$), while processing, the vessel wall is pushed inside the vessel

itself, and comes back above the surface level after the tool has passed. This defect is really unpleasant from a tactile point of view. Increasing the grain angle the parts characterised by a lower density show torn fiber and irregularities, while the more dense parts have always a good aspect.

The walls of vessels of wood processed against the grain at narrow angles ($10^\circ/20^\circ$) tend to be torn, whereas along the grain they are compressed, so the vessels are sharply cut, which results in an excellent final quality. Increasing the angle, torn parts become more important, but never too seriously, especially for the denser parts.

Down-milling

When down-milling along the grain the final quality is very close (as for Douglas fir) to the quality obtained by up-milling. For narrow angles we have the same behaviour as for up-milling; for greater angles torn parts become more important, especially in early wood. As for Douglas fir, for large angles the pre-compression leads a decrease of torn parts (Figure 11).

In wood processed against the grain, "tilted grain" becomes to be the main defect and is characteristic for the surface. Oak has a more homogeneous density, so the defect occurs on both early- and late-wood affecting heavily the final quality of the surface. For narrow angles ($10^\circ/20^\circ$) the quality is good and the vessels are sharply cut, at 30° the defect occurs, affecting the surface until 80° and occasionally also at 90° (see Figure 12).

Profile analysis

Here we compare the profile parameters for the two species and for the different cutting techniques and grain angles. The courses of Pa and Pt for the different species, cutting techniques and grain angles are very clear. For the analysis we chose to use the primary profile (i.e. the measured profile, after the nominal shape has been subtracted), because a) roughness and corrugation analysis are not necessary when the profile characteristics are so obvious, and b) it would be difficult to correctly set the filtering without negative impact on some measurements. From the measured profile, the parameters Pa and Pt have been computed; Pa has been plotted, whereas Pt is reported in tables just to give an idea of the maximal irregularity of the surface.

Douglas fir

Up-milled profiles are not very different on wood processed "along" and "against" the grain, since in both cases some defects occur: against the grain, wood particles are torn away, whereas along the grain the above mentioned conchoidal fractures occur.

Figure 13 and Table 3 show that as the grain angle increases, the surface quality (expressed by means of Pa parameter) decreases.

However, for $\xi=10^\circ$ and 20° Pa is larger when the wood is processed along the grain, although by visual examination this surface would be classified as better; it

is possible that these larger values of Pa occur because of the different elastic behaviour of early- and late-wood (after the passage of the knife the early-wood rises above the surface and forms bumps). It should therefore be noted that within this range ($\xi=10^\circ$ and 20°) Pa is not a good indicator of the surface quality, when processing Douglas fir along the grain with up-milling technique.

After 20° processing against the grain produces worse surfaces than along the grain, with the exception of -70° . Pt shows large irregularities (up to ~ 0.52 mm), that are greater when the wood is processed against the grain.

We may conclude that processing along the grain typically provides better surfaces than processing against the grain (the anomalous value at 70° has not yet been examined in depth). Such conclusion is supported by both the macroscopic examination and the Pa values (excluding for this purpose the above mentioned anomalous values of Pa for $\xi=10^\circ$ and 20°).

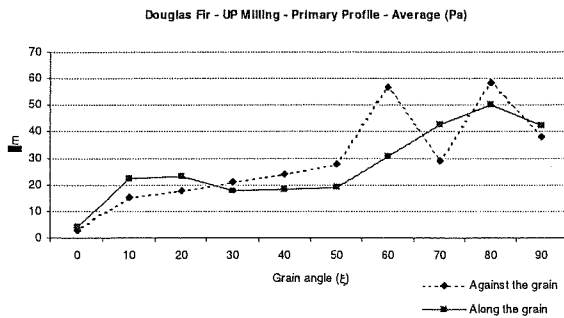

Figure 13 Pa values when processing Douglas fir with up-milling technique

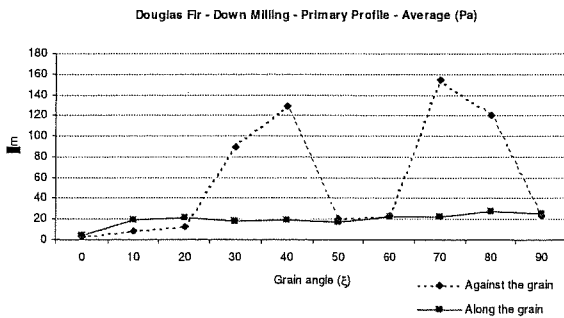

Figure 14 Pa values of Douglas fir processed by down-milling technique

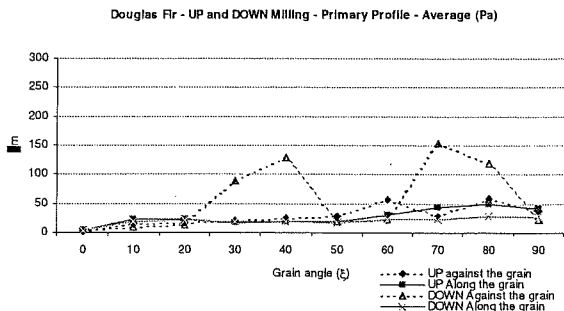

Figure 15 Comparison between Pa values of Douglas fir processed by up- and down-milling

Figure 14 and Table 4 show clearly how the "tilted grain" becomes important for the surface quality when the wood is processed by down-milling: at -30° the defect becomes obvious and Pa increases rapidly, then it decreases between -50° and -60° , where the surface quality increases, and again increases from -70° to -80° .

Pt values indicate that the difference between the highest peak and deepest depression may reach about 1.15 mm, thus showing the great irregularity of the surface.

The whole data sets are plotted together in Figures 15 and 16, which show that processing against the grain always provides worse surfaces than processing along the grain, and that down-milling always provides worse surfaces than up-milling.

Figure 17 and Table 5 clearly show that a surface obtained by up-milling against the grain is worse than a surface obtained by the same technique, but along the grain; however, the difference is not very large and final quality is not very different.

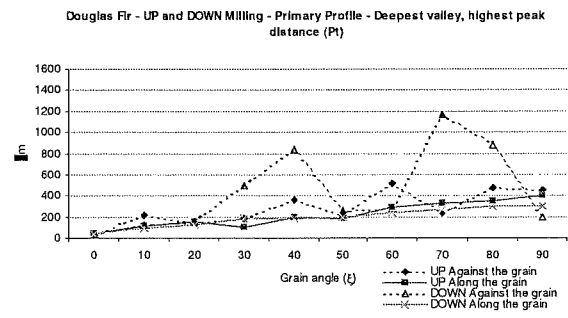

Figure 16 Comparison between Pa values of Douglas fir processed by up- and down-milling

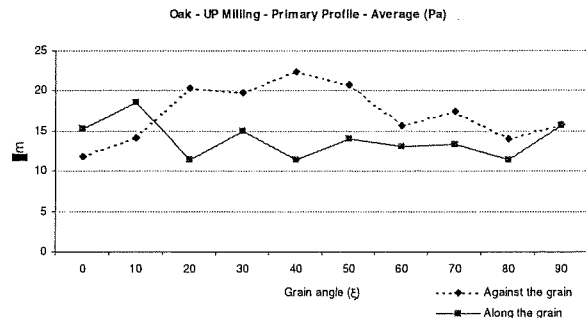

Figure 17 Pa values of oak wood processed by up-milling technique

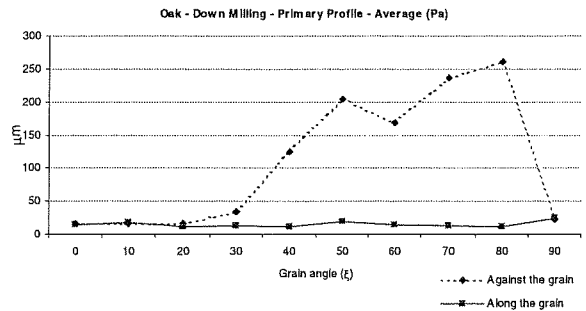

Figure 18 Pa values of oak processed by down-milling technique

Table 3 Pt values of Douglas fir processed by up-milling technique (values are reported in μm)

Grain angle (ξ)	0	10	20	30	40	50	60	70	80	90
Along the grain	46.046	111.92	154.60	107.50	195.03	183.60	288.48	333.38	353.58	400.02
Against the grain	36.07	216.45	149.24	190.92	362.93	215.08	520.51	233.84	472.26	458.67

Table 4 Pt values when processing Douglas fir with Down-milling technique (values are reported in μm)

Grain angle	0	10	20	30	40	50	60	70	80	90
Along the grain	42.603	96.75	120.56	181.70	188.67	198.42	234.82	269.21	299.65	302.35
Against the grain	36.34	121.62	150.55	491.11	837.36	258.12	279.07	1168.00	876.94	198.57

Table 5 Pt values of oak processed by up-milling technique (values are reported in μm)

Grain angle	0	10	20	30	40	50	60	70	80	90
Along the grain	182.35	193.69	187.22	210.89	247.25	216.11	276.95	243.19	233.60	237.37
Against the grain	210.05	187.88	217.67	225.26	272.28	236.12	182.30	274.33	200.70	218.96

Table 6 Pt values of oak processed by down-milling technique (values are reported in μm)

Grain angle	0	10	20	30	40	50	60	70	80	90
Along the grain	208,96	231,17	198,14	201,09	195,64	240,40	229,07	261,95	179,35	315,57
Against the grain	205,16	211,59	187,11	246,39	835,39	1238,00	1156,00	1514,00	1172,00	263,12

Pt shows no large irregularities (~ 0.27 mm), due to the homogeneity of the surface at the high wood density which can result in a smooth cut (note that this is only true for radial surfaces).

Oak

Analysing profiles of surfaces processed by down-milling against the grain, we can easily see how the "tilted grain" defect becomes important for surface quality, in Oak as in Douglas fir. Figure 18 and Table 6 show that at -30° Pa begins to grow up and rapidly increases until -80° ; as with Douglas fir there is a small decrease at -60° .

Pt values shows that the difference between the highest peak and deepest valley may reach $\sim 1,51$ mm, which is the worst value obtained until now.

The whole data sets are plotted together in Figures 19 and 20, that show that processing against the grain always provides worse surfaces than processing along the grain, and that down-milling always provides worse surfaces than up-milling.

CONCLUSIONS

Douglas fir with moisture content of $\sim 11\%$ and oak with moisture content of $\sim 12.5\%$ were studied in connection with wood processing by "up" and "down"-milling techniques at various grain angles. The surfaces were examined by macroscopic analysis, observed with SEM, and profiles were measured, processed and compared. The main results of this research may be summarised as follows.

1. Douglas fir shows a different behaviour between early- and late-wood, and between processing along the grain and against the grain. The surface quality decreases as the grain angle increases, and the surfaces processed along the grain are typically better than those processed against the grain.
2. Douglas fir processed along the grain with up-milling technique provides similar results as with down-milling, in terms of final quality. Up-milling is better for small grain angles (conchoidal fractures are less frequent), while down-milling is better for large grain angles (tendency to generate torn wood particles in the early-wood is smaller). Late-wood typically shows a good final quality.
3. Douglas fir processed against the grain by up-milling provides much better surfaces compared to down-milling. Down-milling produces a defect that is not described by the ASTM D-1666-87 standard. The "tilted grain", as we called this defect, significantly affects the final surface quality.

Oak - UP and DOWN Milling - Primary Profile - Average (Pa)

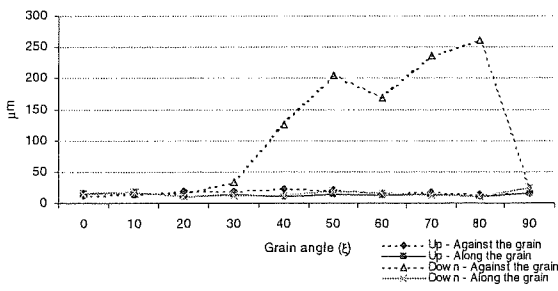

Figure 19 Comparison between Pa of oak with Up- and Down-milling

Oak - UP and DOWN Milling - Primary Profile - Deepest valley, highest peak distance (Pt)

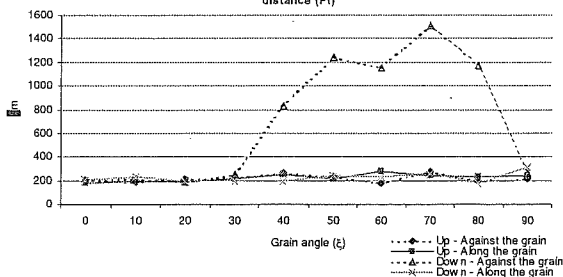
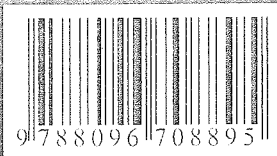

Figure 20 Comparison between Pt in processing Oak with Up- and Down-milling

4. Oak shows a different behaviour (however, the difference is smaller than for Douglas fir) between early- and late-wood, and between processing along the grain and against the grain. The surface quality decreases as the grain angle increases, and the quality of surfaces processed along the grain is in general better compared to those processed against the grain.
5. Oak processed along the grain with up-milling technique provides very similar results as with down-milling, in terms of final quality. However, the following minor defect (producing an unpleasant tactile effect) often occurs: the vessel wall is pushed inside the vessel itself, and comes back above the surface level after the tool has passed.
6. Oak processed against the grain by up-milling provides much better surfaces than by down-milling. Down-milling produces a defect that is not considered by the ASTM D-1666-87 standard – "tilted grain" – that significantly affects the final surface quality. For small grain angles ($-10, -20^\circ$) the surface quality is high and the cut very sharp.
7. For both species the worse surface quality is obtained by down-milling against the grain; followed by up-milling against the grain. Processing along the grain produces similar quality for both up- and down-milling.
8. Up-milling is in general the best technique for machining solid wood.

REFERENCES

- NEGRI, M. & GOLI, G. 2000: Qualità delle superfici lavorate del legno di Abete rosso e di Douglasia valutata con una opportuna classificazione visuale. *Legno Carta e Cellulosa* 6(1):10–21.
- PRECISION DEVICES, INC.: Surface Metrology Guide, web address: <http://www.predev.com/smg>
- CYRA G. & TANAKA C. 2000: The effects of wood-fiber directions on acoustic emission in routine. *Wood Sci. Technol.* 34:237–252.
- LOEHNERTZ, S. P. & VAZQUEZ COOZ, I. 1998: Sawtooth Forces in Cutting Tropical Hardwoods Native to South America, Forest Products Laboratory, Research Paper FPL-RP-567.
- ASTM D-1666. 1987: Standard methods for Conducting Machining Tests of Wood and Wood-Base Materials. Annual Book of ASTM Standards, Volume 04.09 Wood: 257–276.
- GOLI, G., BLERON, L., MARCHAL, R., UZIELLI, L. & NEGRI, M. 2002: Measurement of cutting forces, in moulding wood at various grain angles. Initial results with Douglas fir. To be published in the Proceedings of the Conference: Wood science and engineering in the third millennium – Brasov (RO) – November 17–18th 2002 (in print).



ISBN 80-967088-9-9