



UNIVERSITÀ
DEGLI STUDI
FIRENZE

FLORE

Repository istituzionale dell'Università degli Studi di Firenze

Design and Acoustic Performance of Building Constructions for Multi-Storey Housing: Compendium

Questa è la Versione finale referata (Post print/Accepted manuscript) della seguente pubblicazione:

Original Citation:

Design and Acoustic Performance of Building Constructions for Multi-Storey Housing: Compendium / P. Fausti; T. Carrascal García; B. Ingelaere; M. Machimbarrena; C. Monteiro; A. Santoni; S. Secchi; S. Smith. - ELETTRONICO. - (2014), pp. 213-244.

Availability:

The webpage <https://hdl.handle.net/2158/861594> of the repository was last updated on 2016-02-05T18:56:09Z

Publisher:

COST Action TU0901

Terms of use:

Open Access

La pubblicazione è resa disponibile sotto le norme e i termini della licenza di deposito, secondo quanto stabilito dalla Policy per l'accesso aperto dell'Università degli Studi di Firenze (<https://www.sba.unifi.it/upload/policy-oa-2016-1.pdf>)

Publisher copyright claim:

La data sopra indicata si riferisce all'ultimo aggiornamento della scheda del Repository FloRe - The above-mentioned date refers to the last update of the record in the Institutional Repository FloRe

(Article begins on next page)



Building acoustics throughout Europe

Volume 1: Towards a common framework in building acoustics throughout Europe

11

Design and Acoustic Performance of Building Constructions for Multi-Storey Housing: Compendium

Authors:

Patrizio Fausti¹

Teresa Carrascal García²

Bart Ingelaere³

María Machimbarrena⁴

Carolina Monteiro⁴

Andrea Santoni¹

Simone Secchi⁵

Sean Smith⁶

¹ Engineering Department, University of Ferrara, Italy

² Instituto de Ciencias de la Construcción Eduardo Torroja, IETcc-CSIC, Madrid, Spain

³ Belgian Building Research Institute (BBRI – CSTC – WTCB), Belgium

⁴ University of Valladolid /Applied Physics Department, Architecture School, Valladolid, Spain

⁵ Department of Industrial Engineering, University of Florence, Italy

⁶ Institute for Sustainable Construction, Edinburgh Napier University, Edinburgh, UK

CHAPTER

11

Design and Acoustic Performance of Building Constructions for Multi-Storey Housing: Compendium

11.1. Introduction

This chapter provides an overview of the range of construction types found across Europe to meet various sound insulation requirements for separating (party) walls and floors. The typical construction system, material properties and key influencing factors are described.

The historic nature of sound insulation regulations in each country has led to developments in improvements to the types of constructions. More recently with the advent of stronger sustainability measures and resource efficiency of materials many countries have seen an increase in the use of light-weight structures, such as using timber frame.

The chapter provides details on typical performances for a variety of acoustic descriptors and is a useful reference chapter for architects, acousticians, house-builders, researchers and government departments or local authorities dealing with building standards for sound insulation in housing.

Detailed information on acoustic performance of typical building solutions found all around Europe, can be found in volume 2 of this e book, where the 29 European COST TU0901 countries (plus Australia and New Zealand) have included a specific chapter, which will be referred to as “Country Chapters” hereinafter.

11.2. Compendium of acoustic performance of walls & floors

The typologies of walls, floors and facades built in different European countries are very different from each other and this causes a significant spread in the acoustic performances of buildings.

In particular, the differences are large when comparing countries of north-central and southern Europe. Some examples of typical walls, floors and joints between components in different countries are shown in section 11.3.

Tables 11.1, 11.2 and 11.3 compile data for airborne and impact sound insulation of typical walls and floors found around Europe.

All the data shown in Tables 11.1, 11.2 and 11.3 concerning countries' typical solutions and performance are self-reported by COST TU0901 representatives from each country. The translation of the country descriptor to $D_{nT,A} (50-5000 \text{ Hz})$ in tables 11.1 and 11.2 has been performed based on the equations described in Chapter 4. The figures cannot be considered exact, but rather a good estimation.

Table 11.1 shows in-situ airborne sound insulation data collected from twenty-two countries and focuses specifically on the typical separating walls currently being built involving solid blocks and cellular (hollow) clay blocks, single or double walls. The frequency range for the single weighted values shown is primarily 100 Hz to 3150 Hz.

With reference to masonry walls, the total width of the separating partitions between adjoining dwellings varies from 150 mm to 370 mm.

The performance range is from $D_{nT,w}$ 49 dB to 62 dB, with other values in terms of field sound reduction index R'_w . Noticeably the performance of these constructions is not always relative to their width or mass per unit area. This is primarily due to flanking sound transmission via the external walls and their junctions with the party wall leaf. In some countries the external wall is not "interrupted" at the junction with the separating wall. This continuous inner leaf (or external wall) can reduce significantly the performance.

Table 11.1. Example of current typical separating wall construction using block, clay and concrete in different countries (typical values supplied by TU0901 members).

Country	Wall Description	Approx. Total Width [mm]	Typical Airborne Sound Insulation		
			Country descriptor (100-3150 Hz)	$D_{nT,w}$ (100-3150 Hz)	$D_{nT,A}$ (50-5000 Hz)
Austria	250 mm cellular clay block, lined with 70 mm mineral wool backed gypsum board on dabs o/s and plaster o/s	340	$D_{nT,w}$ 61 dB	61 dB	59 dB
Croatia	20 mm plaster + 210 mm reinforced concrete + 20 mm plaster	250	R'_w 53 dB	52 dB	51 dB
Czech Republic	15 mm lime plaster, 250-300 mm hollow bricks, 15 mm lime plaster	280-330	R'_w 53 dB	52 dB	51 dB
Denmark	200 mm concrete	200	R'_w 55 dB	53 dB	53 dB
France	180 mm thick concrete	180-300	$D_{nT,w} + C$ 53 dB	53 dB	53 dB

Country	Wall Description	Approx. Total Width [mm]	Typical Airborne Sound Insulation		
			Country descriptor (100-3150 Hz)	$D_{nT\bar{w}}$ (100-3150 Hz)	D_{nTA} (50-5000 Hz)
Germany	240 mm brick (density equal or greater 2.000 kg/m ³), plastered b/s + 15 mm plaster	270	R'_w 53 dB	52 dB	51 dB
Iceland	200 mm on site concrete	200	R'_w 56 dB	56 dB	54 dB
Italy	2 x 120 mm cellular clay block (cavity wall) with 40mm cavity filled with mineral wool and lined with 15mm plaster b/s	300	R'_w 53 dB	52 dB	51 dB
Lithuania	2 x 100 mm cellular clay blocks (cavity wall) with 100 mm cavity and finished with 20 mm plaster b/s	340	$D_{nT\bar{w}}$ 56dB	56 dB	54 dB
Macedonia	2 x 120 mm cellular clay block (cavity wall) with 50 mm cavity filled with mineral wool and lined with 30mm gypsum	350	R'_w 53 dB	52 dB	51 dB
Netherlands	120 mm limestone - 60 mm cavity - 120 mm limestone	250-300	$R'_w + C$ 54 dB	55 dB	54 dB
Norway	200 mm on site concrete	200	R'_w 55 dB	53 dB	53 dB
Poland	240 mm calcium silicate wall, plastered on both sides with 10-15 mm thick gypsum plaster	260	$R'_w + C$ 51 dB	53 dB	52 dB
Portugal	2 x 150 mm cellular clay block (cavity wall) with 40 mm cavity filled with mineral wool and render/plaster lining to walls.	370	$D_{nT\bar{w}}$ 50dB	50 dB	49 dB
Serbia	150 mm on site concrete	150	R'_w 54 dB	54 dB	52 dB
Slovakia	200 mm reinforced concrete wall	200-240	R'_w 58 dB	57 dB	55 dB
Slovenia	200 mm reinforced concrete wall, with 50 mm aerated autoclaved concrete and 10 mm plaster finish.	260	R'_w 57 dB	57 dB	55 dB
Spain	80 mm cellular clay block (cavity wall) with 40 mm cavity filled with mineral wool and 10-15 mm plaster b/s. Both leaves resting on elastic bands. 15 mm elastified polystyrene	230	D_{nTA} 61 dB * 100-5000 Hz	62 dB	60 dB
Sweden	200 mm homogenous on-site cast concrete	200	$R'_w + C$ 57 dB	56 dB	54 dB
Turkey	gypsum Plaster b/s+ gypsum board + Metal Profile + 50 mm Glass wool+ 100 mm Concrete Hollow Block	180	R'_w 49 dB (calculated)	48 dB	47dB
UK	100 mm solid aggregate (1500kg/m ³) block (cavity wall) with 75 mm cavity, 8 mm render coat with 12.5 mm gypsum board, wall ties Type A	320	$D_{nT\bar{w}} + C_{tr}$ 53 dB	60 dB	56 dB

Country	Wall Description	Approx. Total Width [mm]	Typical Airborne Sound Insulation		
			Country descriptor (100-3150 Hz)	$D_{nT,w}$ (100-3150 Hz)	D_{nTA} (50-5000 Hz)
Australia	Two leaves of 110 mm clay brick masonry with 50 mm cavity and 50 mm thick glass wool/ polyester insulation and 13 mm plasterboard fixed to studs b/s	300	$D_{nT,w} + C_{tr}$ 45 dB	49 dB	49 dB

Key o/s = one room side; b/s = both room sides

In relation to the range of finishes adopted in each country for these wall types, in central and southern European countries the most predominant was gypsum based plaster, of thickness 10 mm to 30 mm.

As already mentioned, the typologies of floors built in different European countries are very different from each other. The main differences involve the type of finishes adopted (wooden, tiles, etc...) and the way the floating floor is realized.

Table 11.2 shows the airborne sound insulation of some typical separating floors collected from the same countries as Table 11.1. In this case, the total width varies from 200 mm to 450 mm, while $D_{nT,w}$ varies from 49 dB to 59 dB.

If impact performance of floors is considered, it is more complicated to present characteristic impact noise data for typical constructions. This is partly due to the fact that workmanship errors are more significant on impact floors performance than on the airborne sound insulation performance. In this case only a few examples are shown in Table 11.3. The indicated typical values are valid for floor constructions without any significant workmanship errors.

Table 11.2. Example of current separating floor construction in different countries (typical values supplied by TU0901 members)

Country	Description Floor construction	Approx. Total Width [mm]	Typical Airborne Insulation		
			Country descriptor (100-3150 Hz)	$D_{nT,w}$ (100-3150Hz)	D_{nTA} (50-5000 Hz)
Croatia	floor covering + cement glazing + PE foil + EEP + reinforced concrete + plaster	240	R'_w 55 dB	53 dB	52 dB
Czech Republic	180-250 mm concrete slab, mineral wool or elasticised polystyrene 20-40 mm, PE membrane, concrete or anhydrite layer 50 mm	250 -340	R'_w 58 dB	57 dB	55 dB
Denmark	Hollow concrete elements, weight 440 kg/m ² , with wooden floor on joists on elastic supports ($\Delta L_w \geq 20$ dB and $\Delta R_w \geq 3$ dB)	400-450	R'_w 56 dB	Not available	Not available

Country	Description Floor construction	Approx. Total Width [mm]	Typical Airborne Insulation		
			Country descriptor (100- 3150 Hz)	$D_{nT,w}$ (100-3150Hz)	D_{nTA} (50-5000 Hz)
France	200 mm concrete with plastic floor covering	200 -300	$D_{nT,w}+C$ 53dB	53 dB	53 dB
Germany	200 mm concrete with 55 mm floating floor, 20 mm mineral wool and 15 mm plaster	290	R'_w 56 dB	55 dB	54 dB
Iceland	240 mm on site cast concrete	240	R'_w 58dB	57 dB	55 dB
Italy	Beam and block system: 5-10 mm ceramic paving, 40 – 60 mm cement screed, 5-10 mm elastic layer, 200 mm hollow clay blocks + 40 mm concrete slab, and 15 mm plaster	320	R'_w 51 dB	49 dB	49 dB
Lithuania	50-60 mm sand cement screed, 20-50 mm mineral wool, 25-50 mm sand (1400 kg/m ³) and 220 mm reinforced hollow concrete slab	340	$D_{nT,w}$ 55 dB	54 dB	53 dB
Netherlands	240 mm concrete + 20 mm floating material + 50 mm anhydrite or 65 mm screed	320	R'_w+C 58 dB	59 dB	57 dB
Norway	260 mm massive concrete with parquet floor on 3mm ethafoam on top. Total	280	R'_w 55 dB	54 dB	53 dB
Poland	220 mm reinforced concrete slab + 50 mm thick concrete screed on a layer of 20 mm EPS-T polystyrene and 30 mm EPS polystyrene	320	R'_w+C 55 dB	55 dB	54 dB
Portugal	Reinforced concrete slab or beam-and-hollow clay blocks slab	250 -300	$D_{nT,w}$ 51 dB	51 dB	50 dB
Serbia	160 mm concrete slab + 70 mm floating floor	230	R'_w 55 dB	54 dB	53 dB
Slovakia	200 mm reinforced concrete slab + 40 mm mineral wool + 40 mm	280 -300	R'_w 58 dB	57 dB	55 dB
Slovenia	200 mm reinforced concrete slab + 60 mm concrete screed on thin PVC foil and 40 mm mineral wool	300	R'_w 60 dB	59 dB	57 dB
Spain	15 mm laminated wooden floor on 2 mm foam, 85 mm screed on 5 mm polyethylene, 300 mm grid floor with concrete blocks, 15 mm wet plaster finish	360	D_{nTA}^* 54 dB	54 dB	53 dB

* 100-5000 Hz

Country	Description Floor construction	Approx. Total Width [mm]	Typical Airborne Insulation		
			Country descriptor (100- 3150 Hz)	D_{nT_w} (100-3150Hz)	D_{nTA} (50-5000 Hz)
Sweden	250 mm homogenous on-site cast concrete + 15 mm parquet on 3 mm foam	250	$R'_w + C$ 59 dB	58 dB	56 dB
Turkey	14 mm laminated parquet + 2 mm mattress + 60 mm screed + geotextile fabric + 25 mm mineral wool + 180 mm reinforced concrete + 40 mm mortar + gypsum plaster	300	R'_w 53 dB (calculated)	52 dB	51 dB
UK	65 mm min sand cement screed+ 6 mm rubber isolation layer + 150 mm min precast concrete plank (300 kg/m ²) + 150 mm min ceiling void + 12.5 mm plasterboard ceiling	380	$D_{nT_w} + C_{tr}$ 51 dB	55 dB	54 dB
Australia	150 mm thick concrete slab with 28 mm metal furring channels and 65 mm thick polyester insulation and 13 mm plasterboard fixed to furring channels	200	$D_{nT_w} + C_{tr}$ 45 dB	49 dB	49 dB

Table 11.3. Example of impact sound on separating floor constructions in different countries (typical values supplied by TU0901 members).

Country	Description Floor construction	Approx. Total Width [mm]	Typical Impact Noise
Austria	70 mm concrete screed 20 mm mineral wool TDPS 25/20 80 mm loose fill 20 mm mineral wool TDPT 20/20 147 mm CLT cross laminated timber 350 kg/m ²	340	$L'_{nT_w} = 43 - 46$ dB
Denmark	Hollow core concrete slab with wooden floor on joists on PE wedges on elastic supports ($\Delta L_w \geq 20$ dB), with or without mineral wool in the cavity	400-450 mm	$L'_{n_w} = 46 - 52$ dB
Italy	200-280 mm beam and brick floor (plastered 10 mm). 100-120 mm of lightened mortar. Impact insulation resilient layer. 60-80 mm under floor heating system (thermal insulation + cement screed with reinforcing wire mesh). Ceramic tiles or parquet floor	400-450 (350-400 without under floor heating system)	$L'_{n_w} = 50-55$ dB ($L'_{n_w} = 53-58$ dB without under floor heating system)
Slovenia	Wooden floor Concrete screed (60 mm) Thin PVC foil Layer of mineral wool (40 mm) Reinforced concrete slab (200 mm)	320	$L'_{n_w} = 53$ dB

Country	Description Floor construction	Approx. Total Width [mm]	Typical Impact Noise
Spain	350 mm beam and block floor. Ceramic blocks. 10 mm plastered. Impact insulation layer. 5 mm polyethylene layer. 70 mm cement screed with 200x200 mm reinforcing wire mesh 3 mm PE foam 8 mm laminated wood	440	$L'_{n,w} = 46 - 49$ dB
Sweden	Timber joist floor with a heavy floating top floor and a resiliently suspended ceiling made of plasterboard (2 layers).	450	$L'_{n,w} = 49 - 50$ dB
UK	150 mm precast floor with 65mm screed on isolation layer, supported by 100 mm LWA blockwork walls, 12.5 mm plasterboard ceiling on 150 mm metal frame	430	$L'_{n,w} = 54$ dB

11.3. Compendium of Typical Building Constructions

As it can be seen in the “Country Chapters” that can be found in volume 2 [2], there are many different building construction solutions all around Europe. Some of them comply to achieve very high acoustic performance and others just meet the sound insulation requirements. The aim of this “compendium” is to collect and summarise the typical separating walls and floors presented in the “Country Chapters”. To make the structure clear and as straightforward as possible, the constructions are presented in two different sections entitled WALLS and FLOORS respectively.

11.3.1. Walls

11.3.1.1. Heavy-weight walls over interrupted floor structures

In some European countries, interrupted structures are common in single family attached houses or row houses, where each wall is a supporting wall. With this type of structure it is possible to achieve the highest level of sound insulation. The partition consists of two walls separated by a cavity of at least 40 mm. In between both walls, neither connections nor ties are permitted. The concrete slab must be interrupted by the cavity. The only exceptions are the connections at the foundation level and the roof. The concept significantly reduces flanking transmission. The system assures enhanced acoustic comfort between row houses for surface masses of the composing party walls ≥ 150 kg/m² in total.

The description and the picture (Figure 11.1) are taken from the Belgium chapter. This type of structure is used to fulfil the Belgium airborne sound

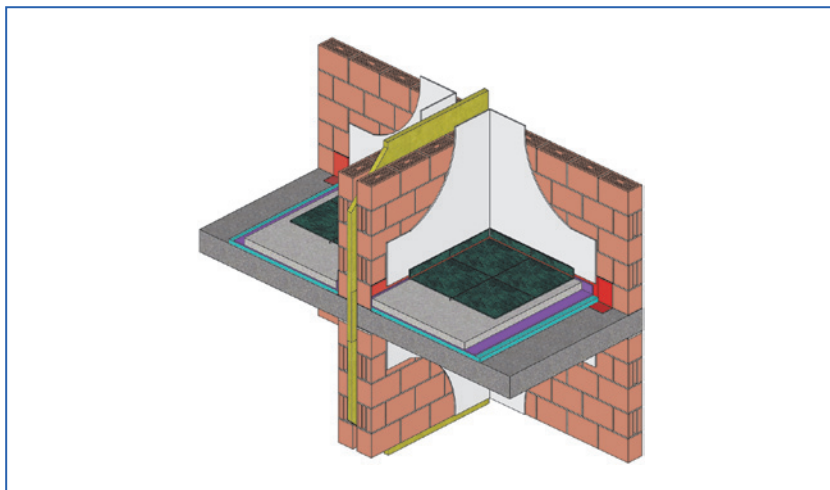

Figure 11.1. Building with interrupted floor slabs and masonry cavity separating wall. [[2] - (Belgium)].

insulation requirements $D_{nT,w} \geq 62$ dB. Similar solutions are used in other European countries: in Netherlands (see Figure 11.2), where the Building Decree (standard) gives the requirements for sound insulation between flats $R'_w \geq 52$ dB; in the UK where the building acoustic requirements are different for England, Wales ($D_{nT,w} + C_{tr} \geq 45$ dB) and for Scotland ($D_{nT,w} \geq 56$ dB); in Germany to fulfil the sound insulation requirement $R'_w \geq 57$ dB for row housing; in Denmark many terraced houses have cavity party walls made from concrete, lightweight concrete or aerated concrete elements (Figure 11.3), that ensure a sound reduction index $R'_w \geq 55$ dB, and if all constructions and junctions are made correctly, much higher performance may be obtained.

Typical new terraced houses have cavity walls made from masonry. Mainly calcium silicate, autoclaved aerated concrete (AAC) or lightweight concrete blocks and bricks are used. The surface mass of the two walls ranges from $m' = 100$ to 300 kg/m² (each). The cavity is typically between 30 and 50 mm and usually filled with mineral wool.

Typical cavity walls in Dutch terraced house, shown in Figure 11.2, are:

- 120 or 150 mm limestone, cavity 60 or 50 mm or 'light' precast concrete (both with a density of 1750 kg/m³) (i.e. 210 kg/m² or 265 kg/m² for each cavity leaf).

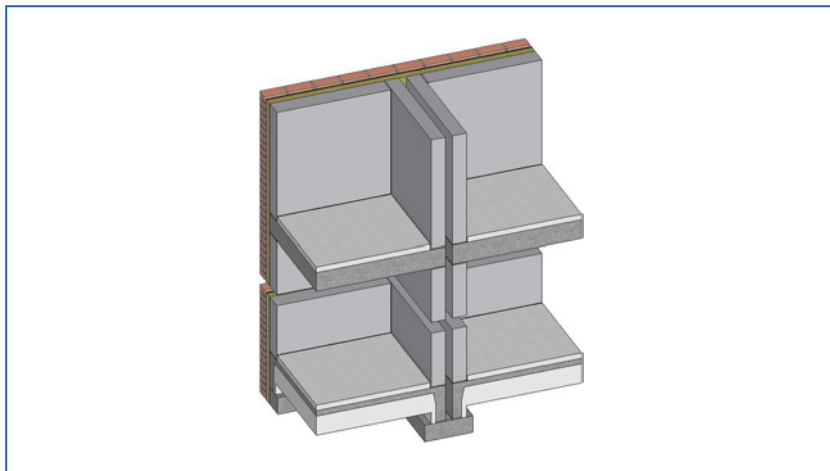

Figure 11.2. Ground floor and first floor details of a Dutch cavity wall in terraced houses. [[2] - (Netherlands)].

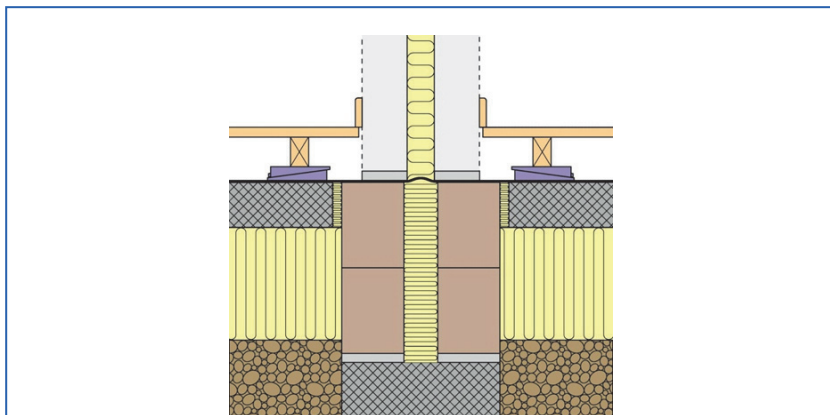

Figure 11.3. Example of Danish heavy cavity wall construction for new terraced housing fulfilling the Danish Building Regulations 2010. Cross section through party wall showing the foundations. [[2] - (Denmark)].

- 90 or 100 mm precast concrete ($\approx 2400 \text{ kg/m}^3$) with a cavity of 40 mm, (i.e. 215 or 240 kg/m^2 for each cavity leaf);
- 120 or 140 mm concrete (2300 kg/m^3) with a cavity of 60 or 80 mm (made at location) (i.e. 276 or 322 kg/m^2 for each cavity leaf).

11.3.1.2. Heavy-weight walls and continuous floor structures

Cavity walls

Masonry cavity walls on continuous slabs are very common in apartment blocks in Europe. Typically, the party wall between two apartments or row houses consists of two leaf masonry walls separated at least 40 mm, with a mineral wool layer. Between both walls, no connections or ties are allowed at all. In some cases, specific acoustic isolation strips are applied below and on top of each masonry leaf. This allows the separating wall to behave as an acoustic double wall even with the continuous concrete slab. Figure 11.4 shows an example of a common cavity wall used in Spain to comply with the sound insulation requirements between dwellings, $D_{nT,A} \geq 50$ dB. This

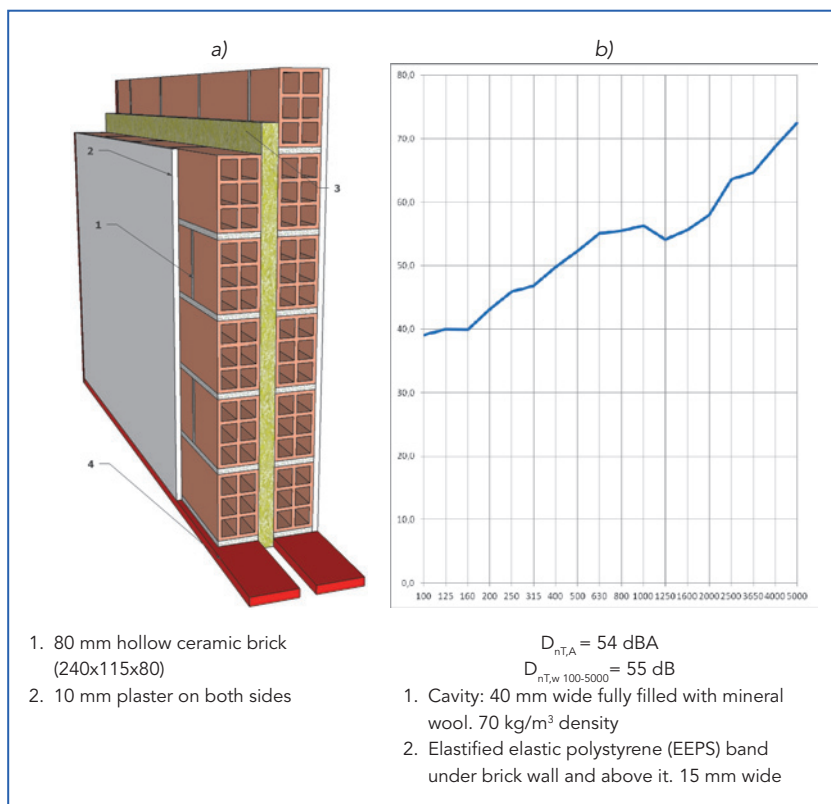

Figure 11.4. Building with continuous floor slabs and acoustic strip under a masonry cavity separating wall. [[2] - (Spain)].

type of walls are non-loadbearing and are usually made of clay blocks with a density of 930 kg/m^3 .

A similar construction technique, without the strips under and above the walls, has been also used in Italy to achieve the sound reduction index $R'_{w} \geq 50 \text{ dB}$. Now the preferred solution consists of a layer of hollow bricks 80 mm thick (with a density between 800 and 900 kg/m^3) and a layer of semi-full bricks 120 mm thick (with a density between 800 and 1000 kg/m^3), plastered with $10\text{-}15 \text{ mm}$ of mortar on both sides and on one side of the cavity. In the cavity there is $40\text{-}50 \text{ mm}$ of mineral wool and $20\text{-}30 \text{ mm}$ of air (Figure 11.5).

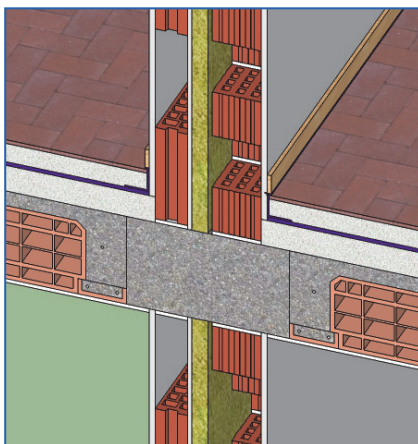

Figure 11.5. Building with continuous floor slabs and a masonry cavity separating wall. [[2] - (Italy)].

Another variation of this type of masonry wall, used in Portugal is a double wall built with “thermal” blocks, each layer 200 mm thick, plastered with 20 mm of mortar on both sides, with an air cavity of 30 mm containing thermal insulation of extruded polystyrene. This ensure to meet the sound insulation minimum requirement given in Decreto-Lei 96/2008, $D_{nT,w} \geq 50 \text{ dB}$ (Figure 11.6).

In the BBRI (Belgian Building Research Institute) Technical Notes, two different solutions are described, which use acoustic strips.

In both of the solutions the party wall between two apartments or row houses consists of two semi-heavy walls (each at least 125 kg/m^2 , e.g.

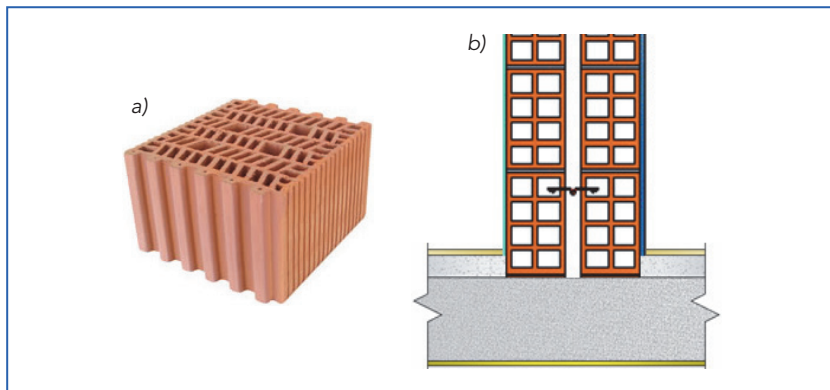

Figure 11.6. a) Example of thermal and acoustic block;
b) Wall-floor joint [[2]- (Portugal)].

140 mm bricks) separated by a cavity of at least 40 mm. Between both walls, no connections or ties are permitted.

In one case specific acoustic strips are applied below and on top of all load-bearing walls. This allows the double wall of the party wall to behave as an acoustic double wall even with the continuous concrete slab (Figure 11.7).

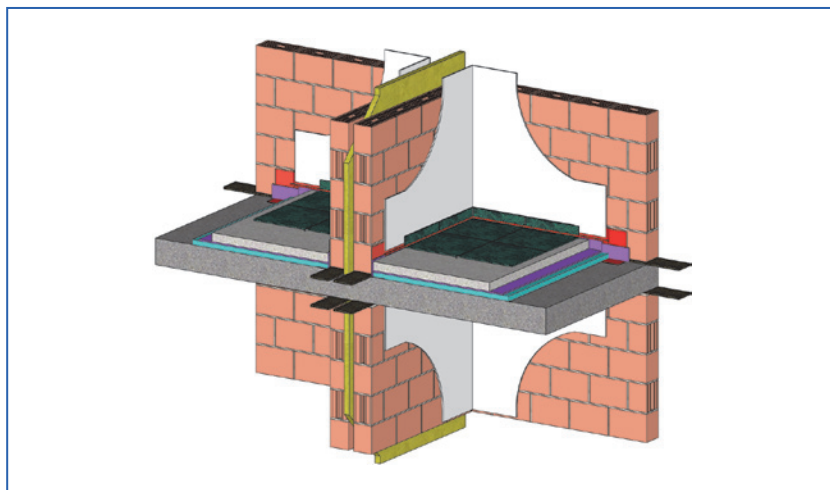

Figure 11.7. Building with continuous floor slabs, acoustic strip
and semi-heavy load bearing double walls. [[2] - (Belgium)].

In the other BBRI solution the party wall between two apartments or row houses consists of two semi-heavy walls (each at least 125 kg/m^2 , e.g. 140 mm bricks) separated by a cavity of at least 40 mm. Between both walls, no connections or ties are allowed at all. Specific acoustic strips are applied below and on top of all load-bearing walls. This allows the double wall of the party wall to behave as an acoustic double wall even with the continuous concrete slab (Figure 11.8).

In the UK the most common form of separating wall are cavity blockwork representing 65% of all walls. For cavity walls the core construction is two leaves of 100 mm blockwork separated by a cavity (Figure 11.9). Wall ties are

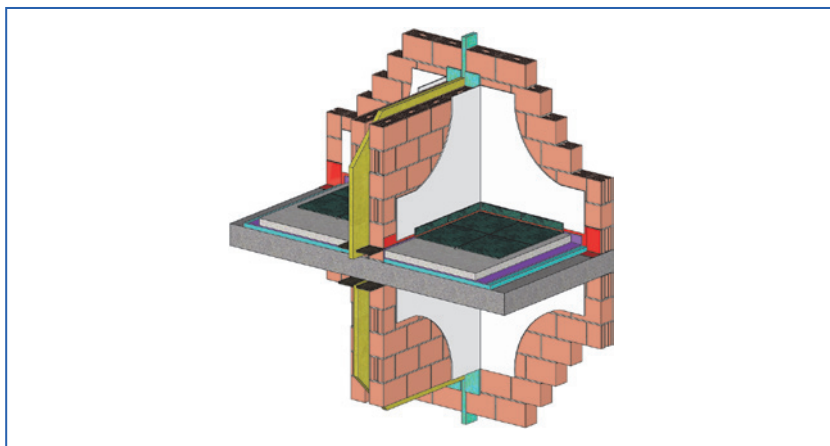

Figure 11.8. Building with continuous floor slabs, acoustic strips and semi-heavy not-load bearing double walls [[2] - (Belgium)].

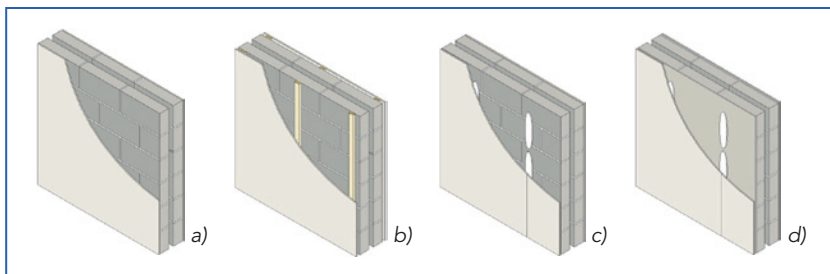

Figure 11.9. Typical blockwork cavity separating walls found in the UK: a) plaster finish ; b) strap and lined with gypsum board ; c) gypsum board on dabs ; d) 8 mm parge coat with gypsum board on dabs. [[2] - (U.K.)].

inserted in cavity walls to brace and stiffen the wall leaves for structural reasons. However, the structural connection formed by the ties can lead to a reduction in sound insulation performance. Hence specific “Type A” party wall ties must be used. Typically in 2013 most cavity masonry blockwork separating walls now have 100mm cavities and are fully filled with mineral wool to reduce cavity heat loss, which also improves sound insulation performance. This type of wall can be used both with continuous and interrupted slab.

In Hungary for walls separating two neighbouring dwellings, 250 mm wide HM-250 sand-lime blocks are used (density 2000 kg/m³), with 10 mm plaster on both sides. In this case the walls should be built on a 4-6 mm thick resilient layer made of agglomerated cork or elastic-cork to avoid rigid joints. The laboratory value of airborne sound insulation of a wall constructed from these bricks is 56 dB. With the resilient under-layer the field value is ensured to be above the requirement $R'_{w} > 51$ dB, that is expressed in field value in the case for walls separating dwellings.

Typical sound insulation performance of UK blockwork walls.

	$D_{nT,w}$	C_{tr}
Aircrete 100 mm block twin leaf wall, 75 mm cavity	59 dB	-6 dB
LWA 100 mm block twin leaf wall, 75 mm cavity	60 dB	-8 dB
Dense block aggregate twin leaf wall, 75 mm cavity	61 dB	-7 dB

Note: all walls have 8 mm parge coat with 12.5 mm gypsum board on dabs

Solid walls

Monolithic walls, in typical Italian partitions used between dwellings, are composed of expanded clay and concrete blocks characterized by an apparent density between 1200 and 1400 kg/m³, plastered with 10-15 mm of mortar on both sides (Figure 11.10). Other types of monolithic walls consist of clay blocks, frequently with big holes filled with concrete, or with additional components in order to improve the thermal insulation.

In the Netherlands, terraced houses and apartment buildings use solid walls made of concrete, or limestone (Figure 11.11) and are used to fulfil the sound insulation requirements. Typical solid walls (in terraced house and apartments) are the following:

- 300 mm limestone (1750 kg/m³ or 525 kg/m²) or 250 mm heavy limestone (2200 or 2300 kg/m³ or 575 kg/m²)
- 230 mm or mostly 250 mm of concrete (2300 kg/m³) or 220 mm precast concrete (\approx 2400 kg/m³) with a mass of 529 , 575 respectively 525 kg/m²

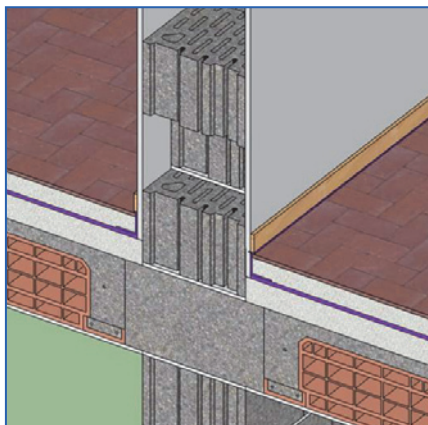

Figure 11.10. Italian monolithic wall with expanded clay and concrete blocks. [[2] - (Italy)].

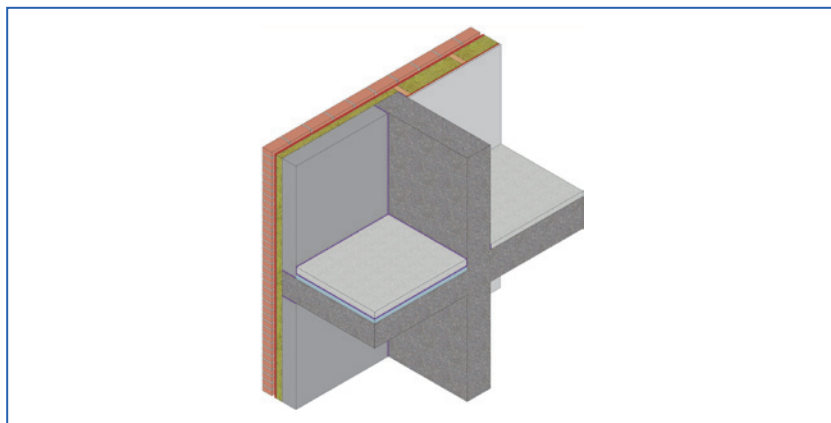

Figure 11.11. Detail of Dutch solid separating wall [[2] - (Netherlands)].

Solid walls made from concrete elements are used in Denmark as party walls in terraced housing and multi-storey housing to ensure a sound insulation $R'_w \geq 55$ dB, as required in the Danish Building Regulations 2010 (Figure 11.12).

In Hungary the most common solution is to use sand-lime bricks. Due to their high density (1400-2000 kg/m³) these bricks can be used on their own, without any additional layers (except for plaster).

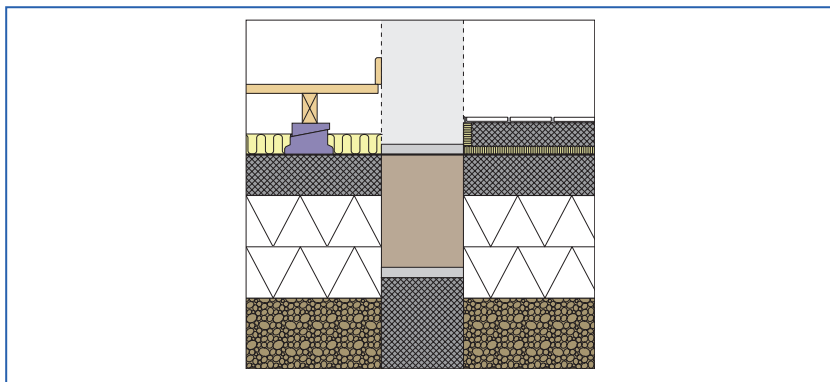

Figure 11.12. Example of Danish heavy solid wall construction for new terraced housing fulfilling the Danish Building Regulations 2010. [[2] - (Denmark)].

Lined walls

Spanish masonry between independent linings walls consists of a single leaf masonry wall with one or two layers of gypsum boards fixed to independent steel frames (Figure 11.13). Each independent lining in most

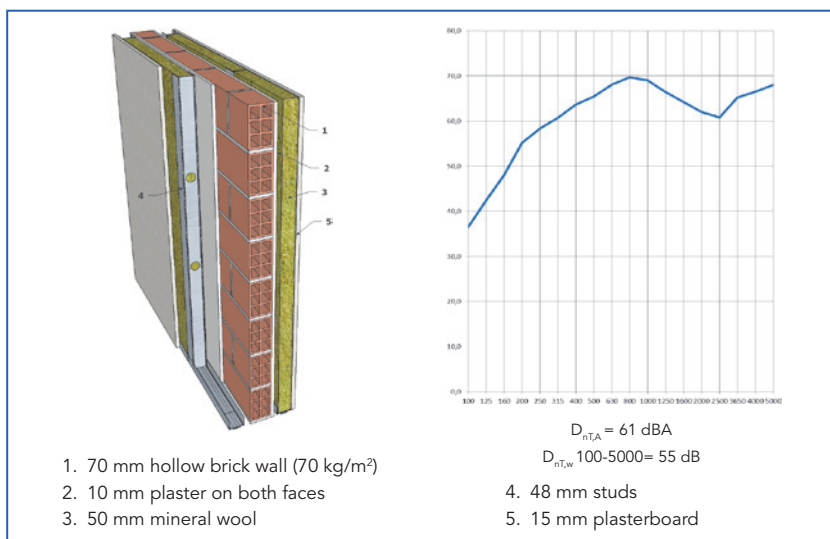

Figure 11.13. Masonry between independent panels;
b) Typical airborne sound insulation. [[2] - (Spain)].

cases increases the insulation of the masonry wall by around 10 dB. Using linings is also a common way to enhance the sound insulation performance of existing buildings.

In Belgium a similar solution is proposed. The party wall between two apartments or row houses consists of a load bearing wall and a gypsum board lining (of at least 2 x 12.5 mm gypsum) on a separated (or vibration disconnected) metal stud frame (Figure 11.14). The cavity width between the gypsum boards and the wall should be such that the mass-spring-mass resonance falls below 50 Hz. The cavity needs to be filled with mineral wool or similar. To optimise thermal inertia of the apartment as well as to limit the vertical flanking transmission, it is interesting to have a concept such that half of the apartment party walls are stone, the other half are gypsum board lining. This building concept is popular as it allows for party walls with a limited width compared to the other building systems.

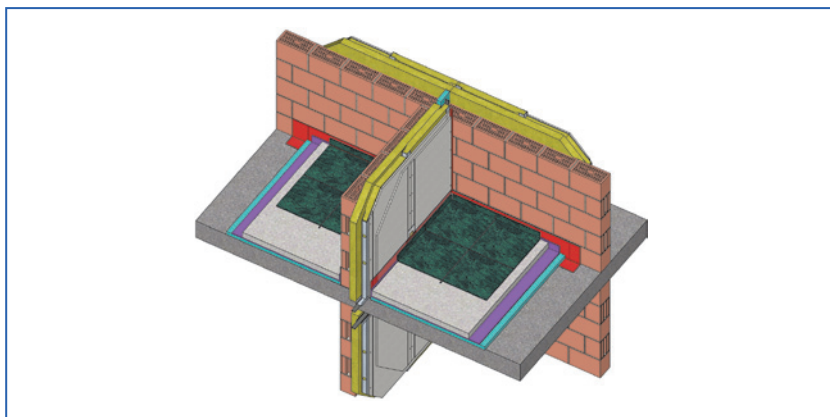

Figure 11.14. Building with continuous floor slabs and a party wall with a single load bearing wall with gypsum board linings [[2]- (Belgium)].

11.3.1.3. Light-weight walls

Many European countries developed light-weight wall constructions fulfilling the sound insulation requirements between dwellings. This section shows either steel or timber frame walls that could be considered a good overview of the different approaches across Europe.

In Austria the standardized sound level difference $D_{nT,w} \geq 55$ is the minimum requirement. Measuring the sound insulation in a multi-family



house where the walls and floors had been constructed according to the Figures 11.15, 11.16 and 11.17 the following weighted standardized sound level differences were found: $D_{nT,w} = 64$ dB between adjacent rooms and $D_{nT,w} = 56$ dB between rooms located on top of each other.

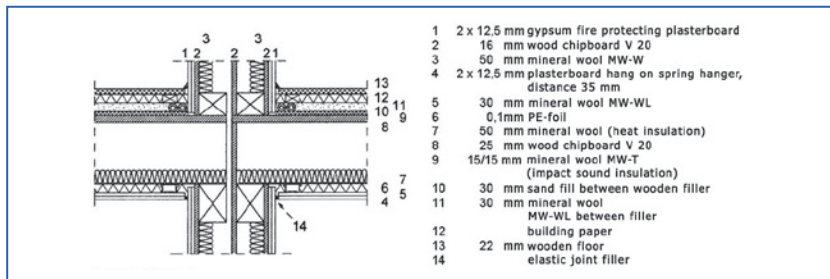

Figure 11.15. Connection between wall separating flats and floor (vertical section) [[2] - (Austria)].

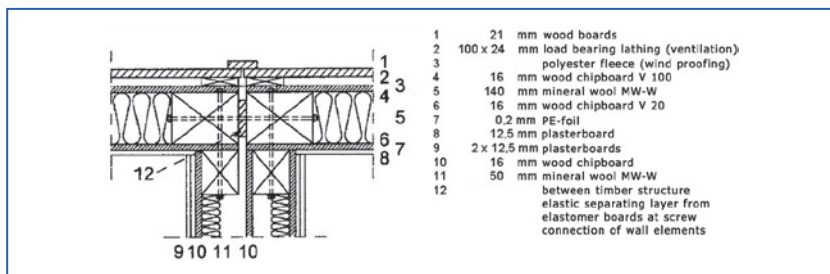

Figure 11.16. Connection between outer wall and wall separating flats (horizontal section) [[2] - (Austria)].

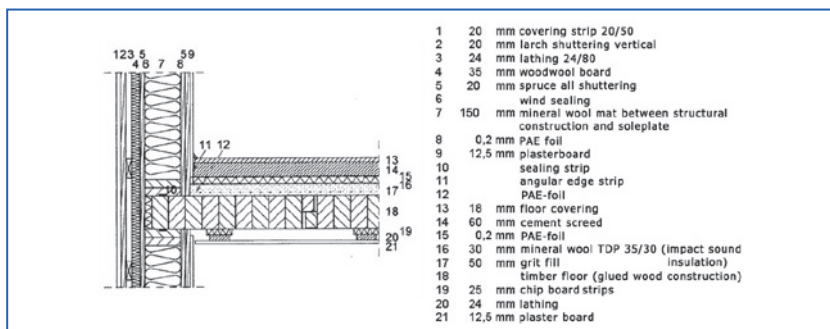

Figure 11.17. Connection between outer wall and floor (vertical section) [[2] - (Austria)].

In Belgium BBRI publishes Technical Notes and also refers to light weight structures. The party wall consists of a double gypsum block party wall (Figure 11.18). The composing walls must have different thicknesses. Cavity distance and surface mass of the blocks should be chosen in such a way that the mass-spring mass resonance shifts below 50 Hz. The load bearing brick wall should be interrupted at the cavity of the party wall to avoid horizontal flanking transmission. The (ceiling) concrete slab should have a surface mass of more than 650 kg/m² to limit the vertical and horizontal flanking transmission. Absolute attention should be paid to the decoupling of the gypsum blocks of the surrounding structure so as to maintain the acoustic double wall behaviour of the party wall.

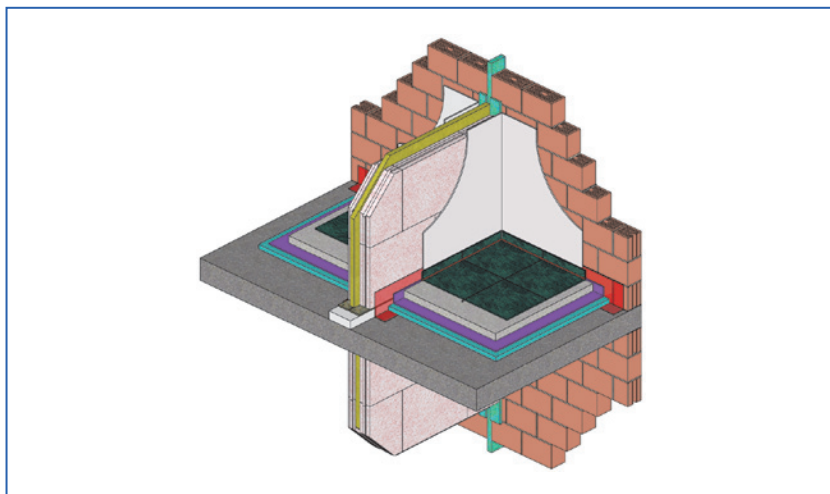

Figure 11.18. Building concepts continuous floor slabs and a party wall with non load bearing walls of gypsum blocks. [[2] - (Belgium)].

Spanish Basic Document DB HR (Protection against noise) also proposes a light-weight separating wall to fulfil the airborne insulation requirements. Steel framed walls with absorbent materials are not as traditional as masonry walls, but metal framed walls are increasingly being used in Spanish buildings. Type 3 walls (Figure 11.19) are two leaf gypsum based board walls, consisting of two 12,5 mm plasterboards screwed directly to double metal studs. Absorbent material batts must be placed between the studs. Typical studs are 48 mm or 70 mm. These walls are non-loadbearing walls built on top of a continuous concrete structure.

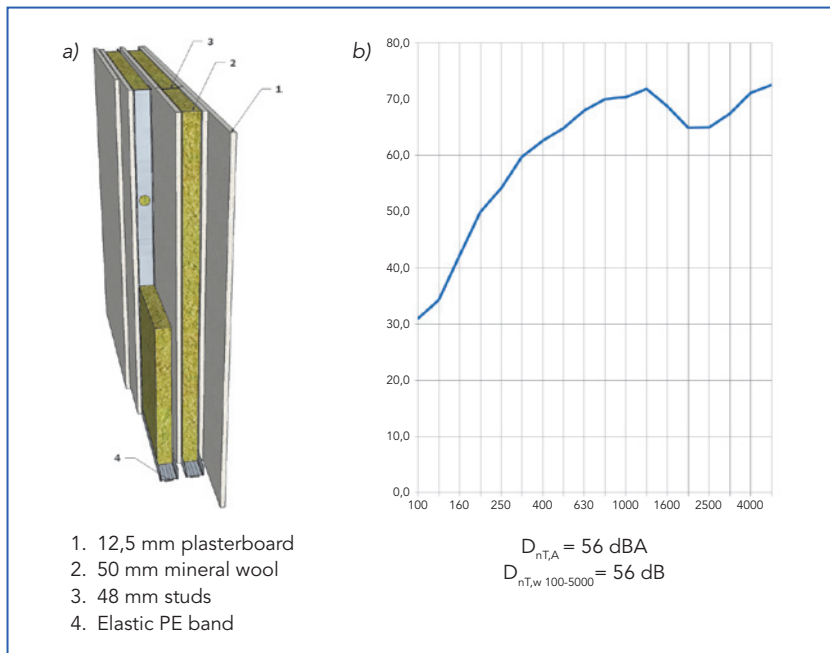

Figure 11.19. a) Separating wall. Type 3. Framed walls with absorbent materials; b) Typical airborne sound insulation. [[2]- (Spain)].

Depending on the height of the room and type of stud, the studs must be tied to ensure structural safety, which results in a decrease in sound insulation of approximately 8 dB. In this sense, it is better to seek the advice of the manufacturer or a consultant to avoid having to tie the studs.

In Denmark to ensure a sound reduction index $R'_w \geq 55 \text{ dB}$ in multi-storey housing, heavy floors could be combined with light-weight party walls. The light-weight wall is plasterboard wall with double framework (Figure 11.20). The surface mass of the plasterboards on each side should be approximately 20 kg/m^2 .

In the Netherlands timber-based buildings (TBB) are in use for terraced houses, always as a cavity wall (Figure 11.21).

Light-weight timber frame constructions in Belgium (Figure 11.22) have seen an expansion towards row houses and even small apartment constructions. Recent research in the BBRI led to significant improvements to these constructions, especially in their low frequency performance. First

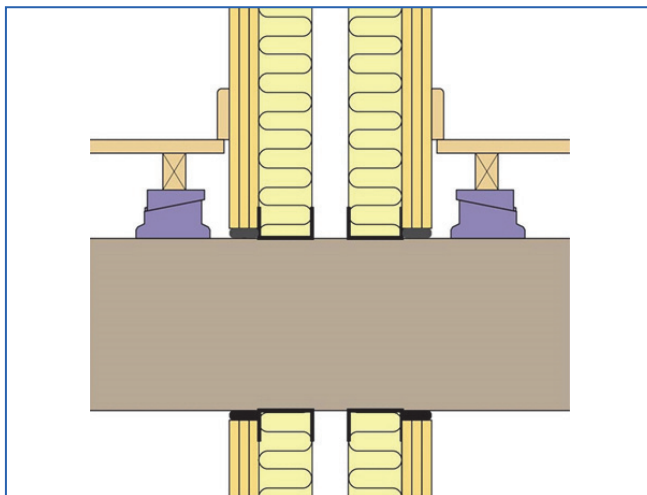

Figure 11.20. Example with a heavy floor combined with a light-weight party wall. [[2]- (Denmark)].

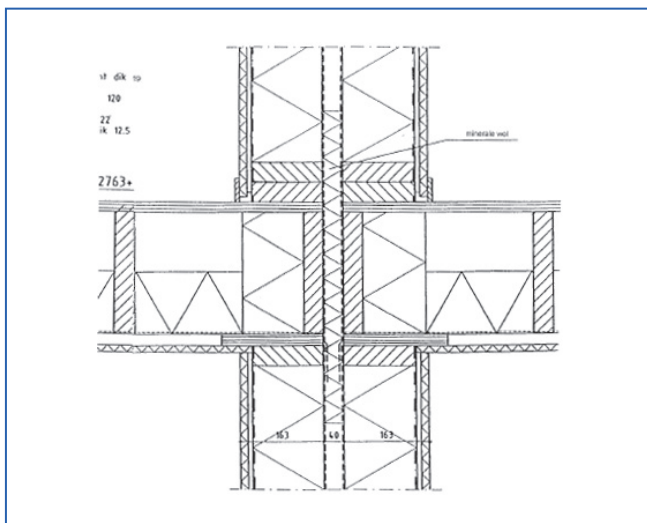

Figure 11.21. Timber based building with cavities of 200 till 300 mm detail of first floor see (SBR 2003) for Class 3 and class 2 (NEN 1070:1999) [[2] - (Netherlands)].

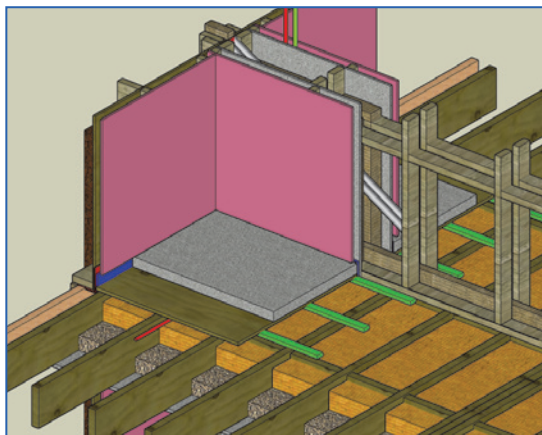

Figure 11.22. Light weight timber frame constructions [[2] - (Belgium)].

new party walls were developed ($R'_w + C_{50-3150} > 64$ dB), and in a second phase, new floors were developed ($R'_{w} + C_{50-3150} > 65$ dB and $L_{nT,w} + C_{1,50-2500} < 48$ dB).

In the UK timber frame separating walls are normally composed of two panels formed from timber 'studs' supported by timber sole plates and are closed by a head plate. The studs are typically 100 x 50 mm with the frames separated by a 30-50 mm cavity. Frames are sometimes strengthened by a sheathing board, which is mounted on the cavity side. Mineral wool is commonly placed on each side of the twin frames and typically minimum 60 mm thick. Timber frame separating walls are commonly finished with two or more layers of gypsum based board with staggered joints. The thickness of each layer ranges from 10 mm to 19 mm and typical two layer linings are 19 mm and 12.5mm gypsum board or 2 layers of 15 mm gypsum board, each side. Timber frame separating walls are either sheathed (Figure 11.23 a) or non-sheathed (Figure 11.23 b) (using minimum 9 mm OSB boarding), depending on structural racking strength requirements and sheathed walls are now the most common construction.

Typical sound insulation performance of UK timber separating walls.

Construction	Airborne $D_{nT,w}$	C_{tr}
Timber non-sheathed wall (240 mm between gypsum layers)	61 dB	-9 dB
Timber sheathed wall (240 mm between gypsum layers)	63 dB	-10 dB

Note: all walls have 60 mm mineral wool (each side) and 2 x 15 mm gypsum board.

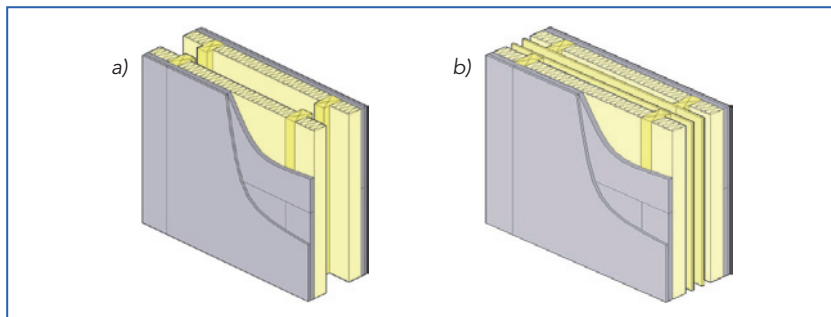

Figure 11.23. Examples of twin frame timber frame separating walls non sheathed (a) and sheathed (b). [[2] - (U.K.)].

11.3.2. Separating floors

11.3.2.1. Heavy-weight floors structure

Heavy-weight separating floors are popular all over the Europe and to obtain a good sound insulation performance, it is common to use floating floors both in continuous and separated structures. There are several types of heavy weight structures, for example in Estonia impact sound insulation requirement, $L'_{n,w} \leq 53$ dB, is usually ensured by concrete floating floors on hollow-core panels or on monolithic concrete slab (Figure 11.24). The weighted normalized impact sound pressure level is typically $L'_{n,w} \leq 48$ -50 dB but also exceptionally good results occurred $L'_{n,w} \leq 45$ dB.

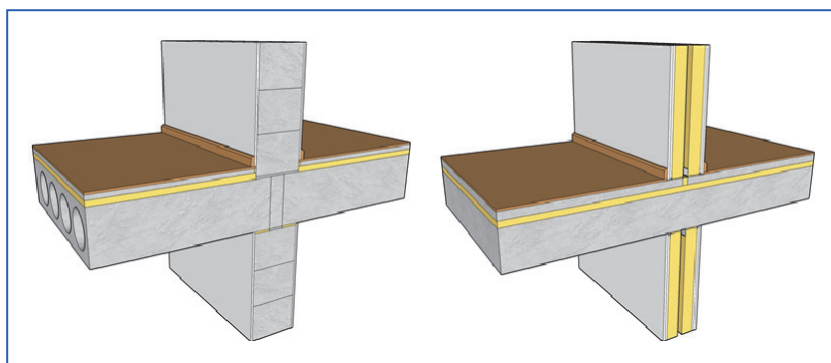

Figure 11.24. left) Massive wall structure and concrete floating floor on hollow-core panels; right) Lightweight wall structure and concrete floating floor on monolithic concrete slab [[2] - (Estonia)].

In Spain beam and block floors and grid floors are the most common. Floor blocks can be either ceramic or light aggregate concrete. Surface mass is 350 kg/m² in average. To control impact noise and fulfil the impact sound insulation requirements, $L'_{nT,w} \leq 65$ dB, it is recommended to build a floating floor consisting of at least 50 mm cement screed and a resilient layer (20 mm mineral wool, 5 mm polyethylene, 20-30 mm EEPS) (Figure 11.25, 11.26). Flanking strips have to be used in the perimeter to avoid flanking structure borne sound. This solution is used in many European countries such as Italy ($L'_{n,w} \leq 63$ dB), Germany ($L'_{n,w} \leq 53$ dB in multi-family houses, $L'_{n,w} \leq 48$ in semi-detached and row houses), Netherlands ($L_{nT,A} \leq 54$ dB), Belgium ($L'_{nT,w} \leq 50$ dB, EAC) and Portugal ($L'_{nT,w} \leq 50$ dB).

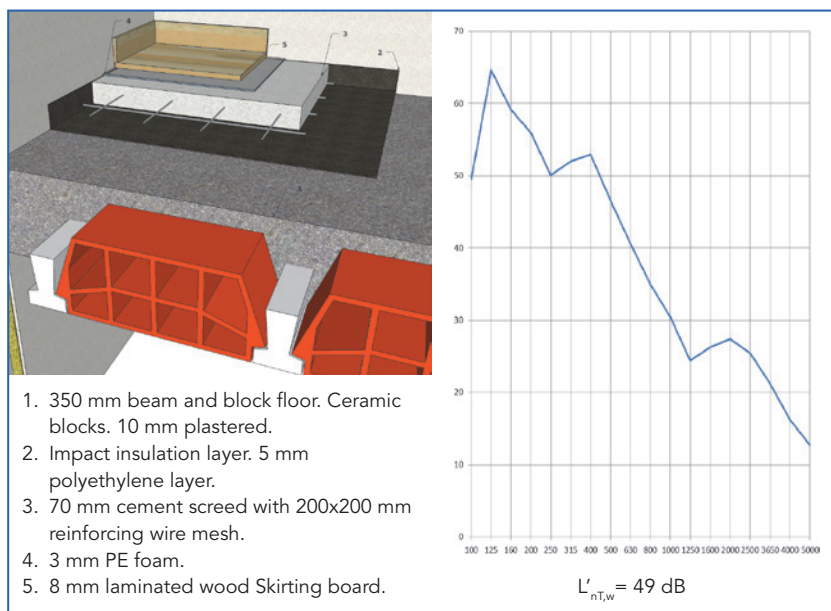

Figure 11.25. Example of a typical beam and block floor with a floating floor consisting of a screed on a polyethylene layer [[2] - (Spain)].

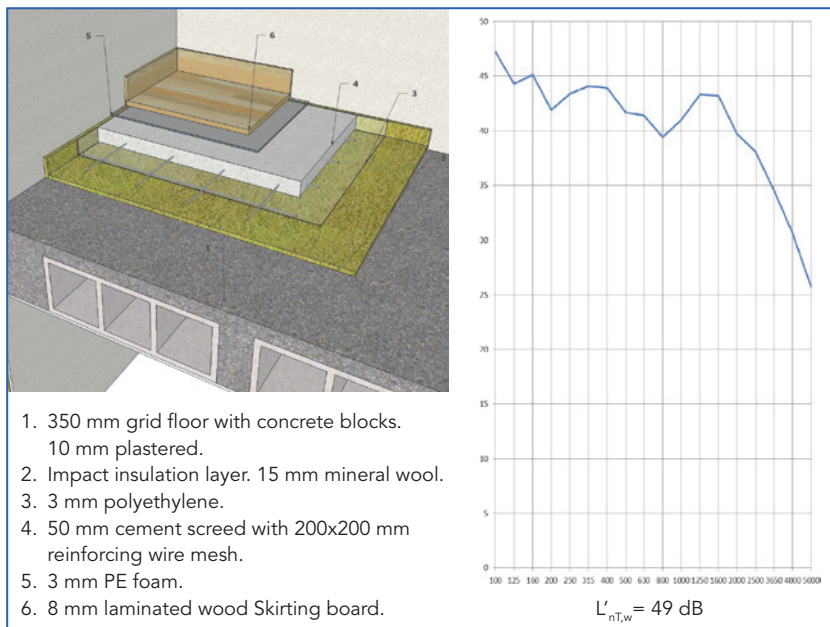

Figure 11.26. Example of a typical grid floor with a floating floor consisting of a screed on mineral wool [[2] - (Spain)].

In Denmark most new apartment houses are made from concrete elements. It is recommended that slabs have a surface mass of 440 kg/m^2 . The wooden floor finish on joists on PE floor wedges must have an impact sound pressure level reduction of $\Delta L_w \geq 20 \text{ dB}$. The wall is made from 200 mm concrete wall elements (Figure 11.27). This solution ensures compliance with the impact sound insulation requirements given in the Building Regulations 2010: $L'_{n,w} \leq 53 \text{ dB}$.

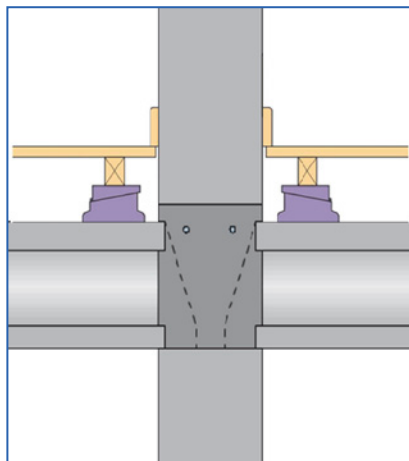

Figure 11.27. Example of heavy wall / heavy floor construction for new apartment houses fulfilling the Danish Building Regulations 2010. [[2] - (Denmark)].

The minimum impact sound insulation requirements for new build houses are $L'_{nT,w} \leq 62$ dB in England and in Wales and $L'_{nT,w} \leq 56$ dB in Scotland. The most common form of separating floor utilises precast concrete floor slabs typically 150 mm to 200 mm thick with a minimum mass per unit area of 300 kg/m^2 . Floor finishes may include floating screeds isolated on resilient layers, floating timber floor finishes on resilient battens or cradles with various timber or metal frame ceiling supports.

Most common separating precast concrete floor performance in UK.

Construction	Airborne $D_{nT,w}$	Ctr	$L'_{nT,w}$
150 mm precast floor with 65 mm screed on isolation layer, supported by 100 mm LWA blockwork walls,	59 dB	-6 dB	54 dB
12.5 mm plasterboard ceiling on 150mm metal frame			

In Finland the minimum requirements for airborne sound insulation and impact noise are $R'_w \geq 55$ and $L'_{n,w} \leq 53$. Typical heavy weight solutions (Figure 11.29) to fulfil these requirements are:

In Hungary the most common heavyweight separating floor construction is a beam and block system with floating floor. The height of the beams with the hollow ceramic or concrete blocks is 190 mm, which is covered with 40, 60 or 85 mm thick concrete layer (depending on the design). The impact sound

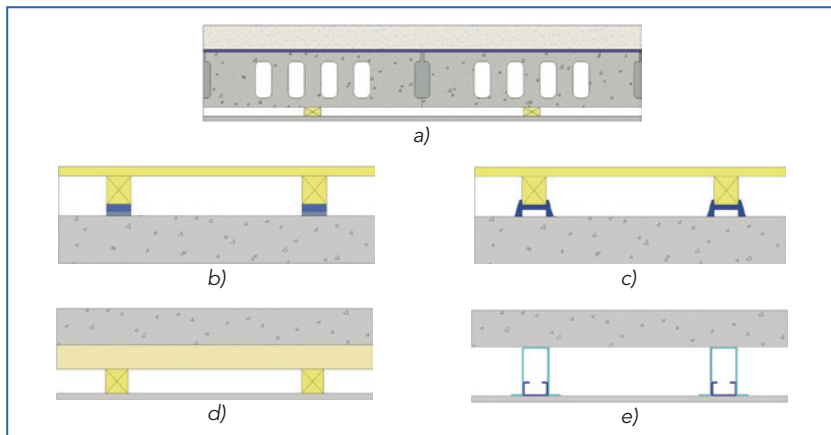

Figure 11.28. Examples of precast concrete separating floors with
a) screed finish on isolating layer; b) use of resilient flooring battens;
c) use of resilient cradle floor deck systems; d) Timber counter strapped
ceiling frames; e) metal frame ceilings. [[2] - (U.K.)].

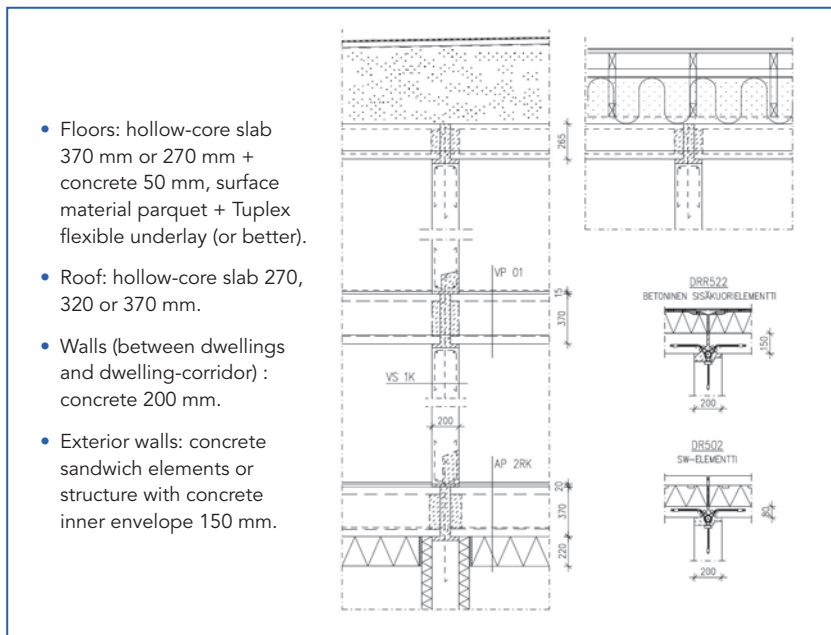

Figure 11.29. Details of typical separating floor. [[2] - (Finland)].

insulation layer is typically 30 mm thick mineral wool or a double layer consisting of a load bearing extruded polystyrene board, a thin insulation foil, and 30 mm thick mineral wool layer. In the latter case the polystyrene layer is used for hiding the pipes. The floating layer is typically 60 mm screed with 5 mm thick PE foam perimeter isolating strip. If the top layer is laminated floor, it is laid on 3 mm thick felt or PE layer, whereas the ceramic tiling is glued directly onto the screed (Figure 11.30). As the properly built floating floor increases the airborne sound insulation by 3-5 dB, the resulting floor construction satisfies both the airborne ($R'_w + C > 51$ dB) and the impact ($L'_{nw} < 55$ dB) sound insulation requirements for the separating floor.

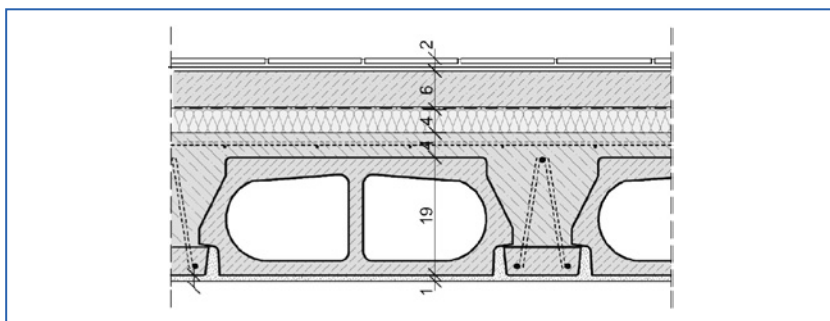

Figure 11.30. Cross-section of the most typical heavy-weight floor construction, the layers from top to bottom: floor tiling, screed, foil, impact sound insulation layer, beam-and-hollow-block floor system with concrete upper layer, parge coat. [[2] - (Hungary)].

11.3.2.2. Light-weight floor structure

Certainly heavy-weight constructions are widely used in Europe, however in some countries light-weight and timber based solutions are more common in some regions (e.g. Scotland - 70% is timber frame). More recently in some European countries lightweight constructions are increasingly being used. Some examples are shown in figures 11.31 to 11.33.

In Norway for example row houses/attached houses are most commonly built with lightweight constructions (Figure 11.31).

Description of typical separating wall:

- 2 x 13 mm gypsum boards on separate studs with 70 mm insulation, 20-30 mm air cavity, 2 x 13 mm gypsum boards on separate studs with 70 mm insulation.

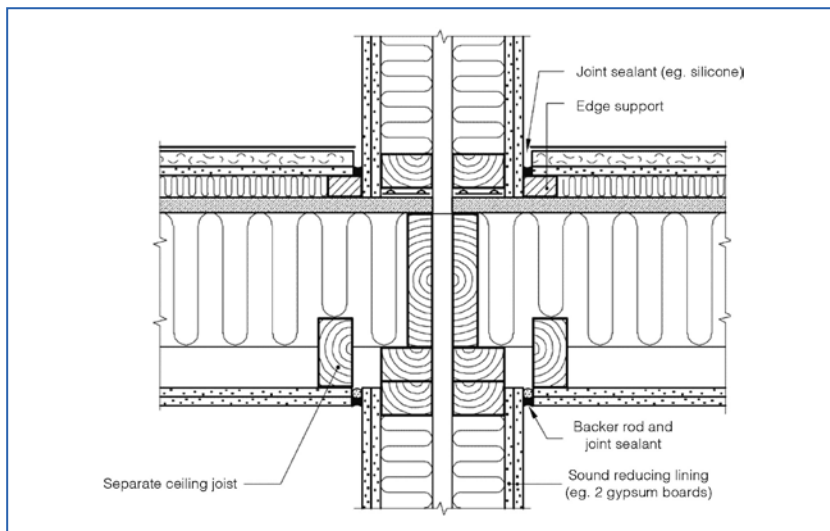

Figure 11.31. Generic detail showing typical separating wall and floor and the junction between them in terraced housing [[2] - (Norway)].

Description of typical separating floor:

- Lightweight floating floor (parquet, resilient layer, 22 mm flooring particle board, 20 mm mineral wool), load-bearing wood beams with mineral wool in cavity, 2 x 13 mm gypsum boards on separate beams or resilient bars/hangers.

The constructions will in most cases fulfil the minimum requirements, but complaints have been registered, especially where measured values for impact sound pressure levels are just within the requirements. The reason for this is most likely related to high levels in the frequency range 50-100 Hz, as the $C_{i,50-2500}$ adaptation term can be as high as +8 dB, resulting in $L'_{n,w} + C_{i,50-2500} > 58$ dB.

In the UK recently, timber core floor design has diversified into a variety of other materials and engineered solutions, such as engineered 'I-joists' and metal web joists. Depths are typically 220 mm to 302 mm for 'I-joists' and commonly 253 mm for metal web joists (Figures 11.32 and 11.33).

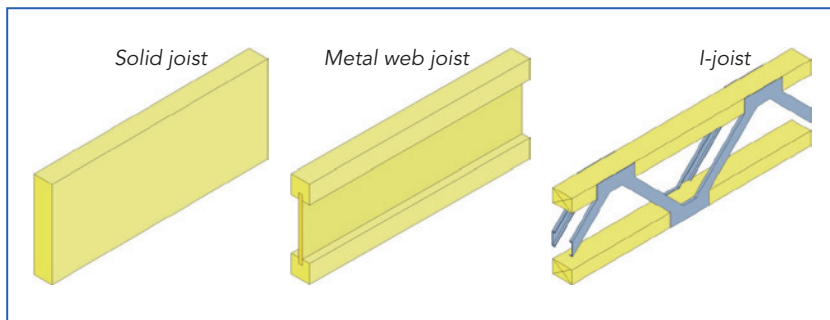

Figure 11.32. Examples of separating floor joists [[2] - (U.K)].

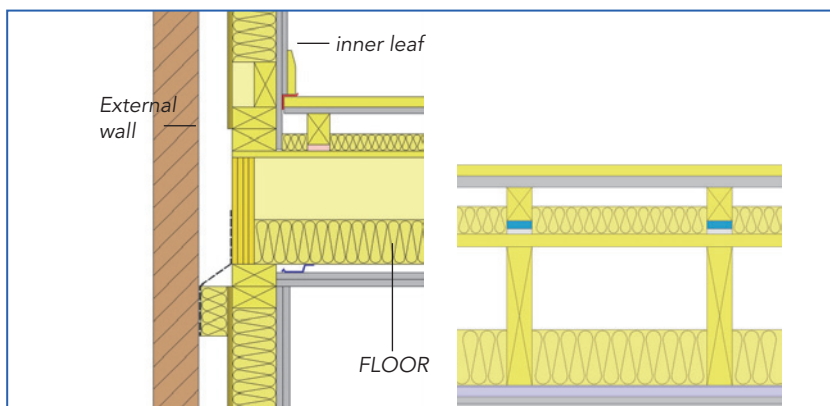

Figure 11.33. Left: Junction with external wall Right: Section of separating floor [[2] - (U.K)].

The floor is usually built using 16 mm resilient ceiling bars to support the ceiling, floating resilient battens with a layer of 19 mm gypsum and 18 mm wood fibre board above.

Typical sound insulation performance of UK timber separating floors.

Construction	Airborne $D_{nT,w}$	C_{tr}	$L'_{nT,w}$
18 mm board, 19 mm gypsum, 70 mm resilient battens, 25 mm insulation, 18 mm subdeck, 240 mm i-joist floor,	62 dB	-11 dB	53 dB
100 mm insulation, 16 mm resilient bars, 2 x 15 mm gypsum			

11.4. Acknowledgements

The authors of this chapter want to thank all COST TU0901 members for their input for Tables 11.1, 11.2 and 11.3 and for allowing reproducing contents from the corresponding Country Chapter in this “compendium chapter”.

11.5. References

- [1] COST Action TU0901 «*Integrating and Harmonizing Sound Insulation Aspects in Sustainable Urban Housing Constructions*». www.costtu0901.eu.
- [2] Building acoustics throughout Europe- Volume 2: Housing and construction types country by country- (Figures and corresponding references can be found in chapters 1, 2, 5, 6, 7, 11, 13, 17, 18, 20, 25, 27 and 29).