



UNIVERSITÀ
DEGLI STUDI
FIRENZE

FLORE

Repository istituzionale dell'Università degli Studi di Firenze

Redesign of a historical masonry stronghold incorporating a base isolated floor

Questa è la Versione finale referata (Post print/Accepted manuscript) della seguente pubblicazione:

Original Citation:

Redesign of a historical masonry stronghold incorporating a base isolated floor / S. Sorace; G. Terenzi. -
ELETTRONICO. - (2008), pp. 148-1-148-10. (Intervento presentato al convegno 14th International Brick &
Block Masonry Conference tenutosi a Sydney, Australia nel 17-20 February 2008).

Availability:

This version is available at: 2158/322839 since: 2018-11-21T18:58:23Z

Publisher:

University of Newcastle

Terms of use:

Open Access

La pubblicazione è resa disponibile sotto le norme e i termini della licenza di deposito, secondo quanto
stabilito dalla Policy per l'accesso aperto dell'Università degli Studi di Firenze
(<https://www.sba.unifi.it/upload/policy-oa-2016-1.pdf>)

Publisher copyright claim:

(Article begins on next page)

REDESIGN OF A HISTORICAL MASONRY STRONGHOLD INCORPORATING A BASE ISOLATED FLOOR

S. SORACE⁽¹⁾, G. TERENCE⁽²⁾

⁽¹⁾Department of Civil Engineering
University of Udine
Udine, Italy

⁽²⁾Department of Civil and Environmental Engineering
University of Florence
Florence, Italy

SUMMARY

The central wing of an earthquake-damaged historical castle in Italy is redesigned in this study, by assigning it a new destination as a museum. Traditional techniques are used for rebuilding the masonry walls and the wooden floors. At the same time, a base isolation solution is adopted for the ground floor, where the main exhibition hall, including two marble statues, is accommodated. The seismic performance of the statues is comparatively assessed for the base isolated floor and a conventional fixed base configuration, by referring to three limit states postulated herein, represented by the attainment of rocking, damage and collapse response conditions.

INTRODUCTION

Redesign and rebuilding of historical buildings is a current issue in areas hit by severe earthquakes. This is also the case of the region of Friuli in north-eastern Italy, where several medieval castles belonging to private owners have not yet been fully repaired or rebuilt after the devastating 1976 earthquake. One of the most important strongholds in the region, the Castle of Prampero, was only recently submitted to an early rebuilding intervention of the northern tower. An intervention on the central portion of the castle will follow soon.

In this study, a complete architectural and structural redesign of the main portion of the castle is developed, by suggesting for it a new use as a museum. Within this design, two large exhibition halls are planned on the ground and first floors, as compared to the original arrangements of the interiors. Because the hall situated at ground level is expected to exhibit two important statues of the new museum collection, a seismic isolation solution is formulated for this floor, by separating it from relevant perimeter walls, and creating a basement level to hold the bearing columns of the base isolation.

The structural analyses developed for the mobile floor include a computational investigation of the possible rocking effects of the statues. These effects were preliminarily investigated in (Sorace and Terenzi 2007) by a simplified schematisation of the statues as rigidly supported masses, and the incorporation of gap elements at their bases.

In this paper, a more advanced investigation is proposed, including a complete three-dimensional modelling of the statues, and a special assembly of sliding elements at their

pedestals. The performance of the statues is comparatively assessed in base isolated and standard fixed base configurations by referring to three limit states specially postulated within this study, represented by the attainment of rocking, damage and collapse response conditions.

The essential aspects of the architectural redesign project; the structural solutions adopted for the masonry walls and wooden floor to be rebuilt; the characteristics of the base isolation system of the ground floor and its technical and construction details; the finite element models of the mobile floor, the statues and the pedestal-floor contacts; and a synthesis of the non-linear dynamic analyses carried out to assess the seismic performance of the adopted protection technology, are presented in the next sections.

REDESIGN OF PRAMPERO CASTLE CENTRAL WING

The current conditions of the castle are schematized in the rendering in Figure 1, which shows that only the farthest wing, named northern tower, was rebuilt, whereas the remaining parts are either totally destroyed, or reduced to a heap of ruins. Only some stumps of the ground floor and walls on the first floor remain for the central portion of the castle, which makes the object of this redesign project.

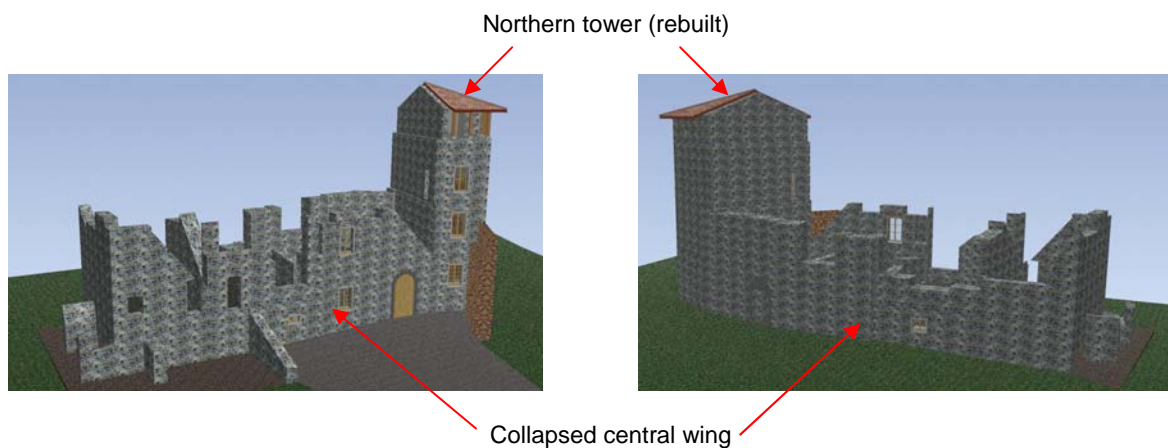

Figure 1. Remaining parts of the castle

A global photographic view of the northern tower during the restoration works, and detailed views of its front, including the survived main door of the central part of the castle, and the stone blocks already arranged to be connected to the perimeter walls of the central zone, when it will be rebuilt, are shown in Figure 2. It can be observed that the original stones recovered from the collapsed walls will be used for reconstruction, in combination with high-strength hydraulic-lime mortars. More photographic images of the ruined walls of the central portion of the building, currently surrounded by vegetation, are displayed in Figure 3.

The rebuilding hypothesis of the central zone is illustrated in Figure 4, where the renderings of the façade and the longitudinal cross section of the building, which incorporate also the northern tower, are drawn. As illustrated in Figure 5 and the section in Figure 4, the only internal change introduced in this design, with respect to the original configuration, consists in eliminating the median wall on the two lower stories, in order to obtain two single exhibition halls at these levels. This choice implies a rotation of the pre-existing plot of the wooden floors, which consequently reach a new maximum span slightly exceeding 8 meters.

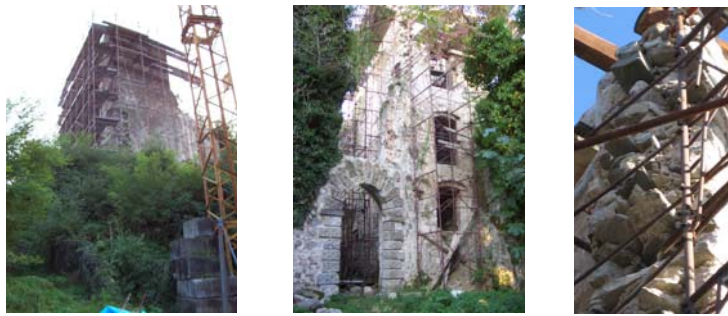

Figure 2. Views of the northern tower during the rebuilding works

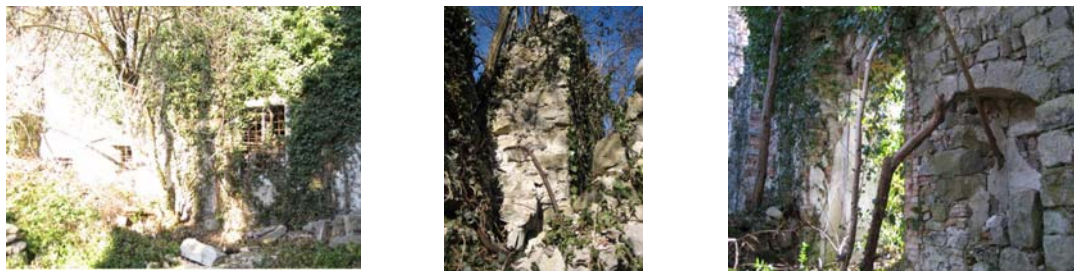

Figure 3. Views of the ruins of the central zone

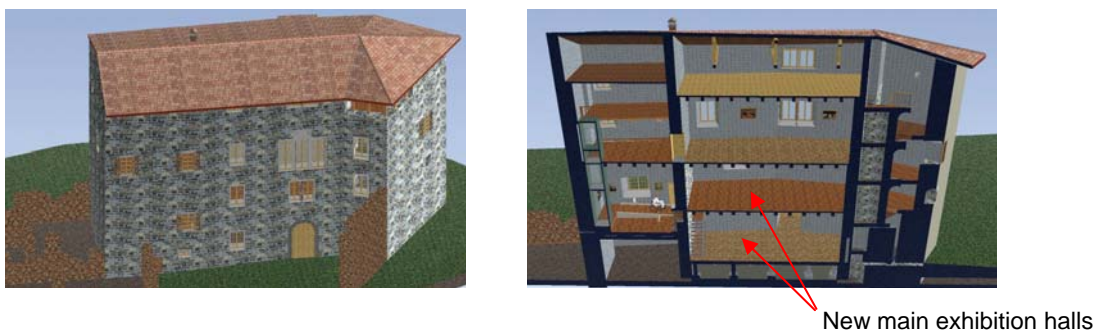

Figure 4. Rendering of the redesigned central wing

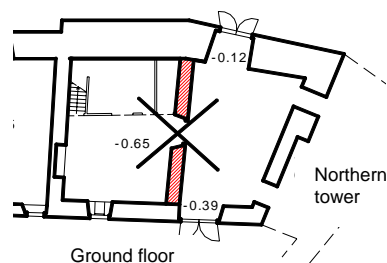

Figure 5. Ground floor plan and removal of the original median wall

A wooden-reinforced concrete composite structure is adopted for the new floors, with steel connectors inserted in the wooden beam extrados by “dry” screwing, as shown in the cross section in Figure 6. This solution ensures remarkable stiffness and strength characteristics to the floors, with regard to vertical as well as seismic loads. At the same time, the beam dimensions – equal to (28x36) cmxcm – and their respective distances (1 m), are kept within

reasonable limits. The beams are anchored at each floor to continuous reinforced concrete beams, with an average width equal to $2/3$ of the wall thicknesses, which offer an effective connection to the upper reinforced concrete slab of the floor (Figure 6).

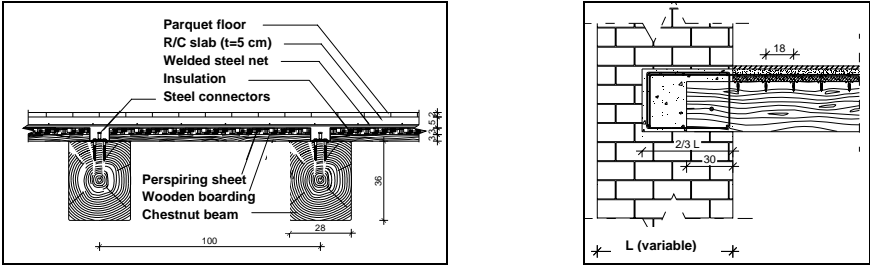

Figure 6. New wooden floors

DESIGN OF THE BASE ISOLATED GROUND FLOOR

The ground floor design plan is drawn in Figure 7, where the positions of the two similar statues to be accommodated in the main exhibition hall, according to the new museum layout, are highlighted with red dots.

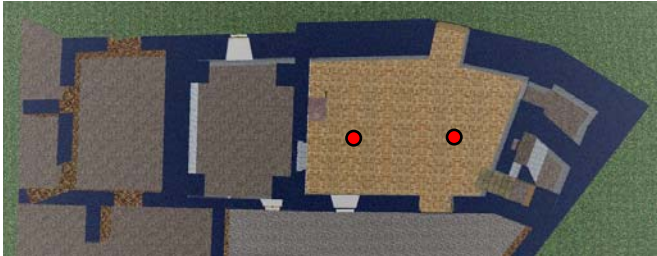

Figure 7. Architectural plan of the ground floor and positions of the two statues

The solution adopted for the base isolation system consists in a steel floor, whose structural plan is represented in Figure 8, supported by four high damping rubber bearings (HDRBs) and eleven steel-Teflon sliders. All bearings are placed on top of short reinforced concrete columns built on the basement level, as illustrated in the rendering in Figure 9, which also shows the plot of the main steel beams, and the installation of the secondary beams and the upper HI-bond corrugated steel sheet before the casting of a top reinforced concrete slab.

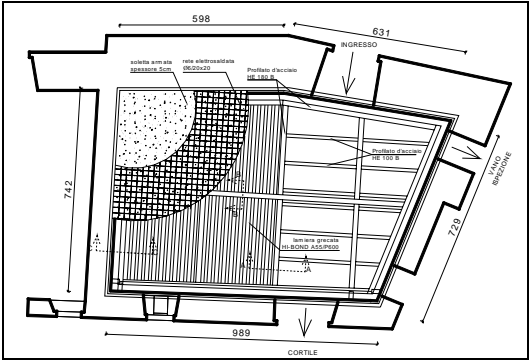

Figure 8. Structural plan of the ground floor

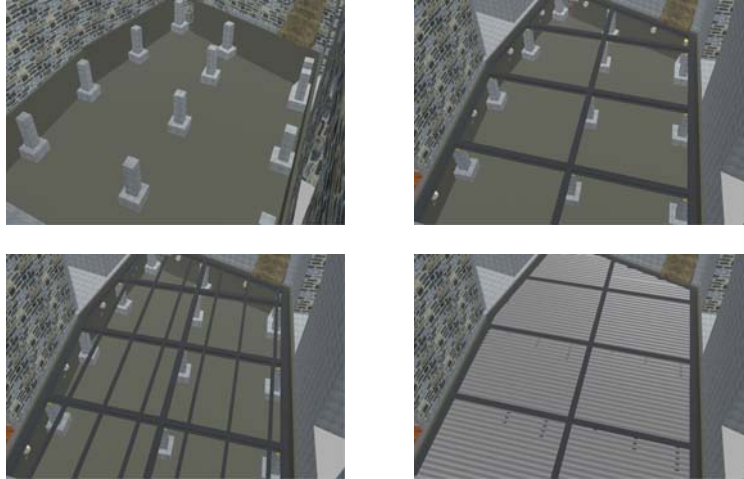

Figure 9. Construction steps of the ground floor

Two views of the basement level are reported in Figure 10, showing the main entrance and the bottom side of the floor, with the technical volume created at this level, to be used for the necessary inspection, check and maintenance activities of the isolation system.



Figure 10. Basement level and bottom side of the ground floor

CHARACTERISTICS OF THE BASE ISOLATION DEVICES

The four HDRB isolators adopted in this design have a total height H of 206 mm, top and bottom steel plates included, and a diameter D of 300 mm. The plates are square in shape, with 380 mm long sides. The remaining geometrical parameters (t_e = total rubber thickness; t_i = single rubber layer thickness; t_s = single steel layer thickness; n_1 = number of layers; S_1 = primary shape factor = A'/L , where A' = steel layer net area; S_2 = secondary shape factor = D/t_e) and mechanical parameters (G_{dyn} = dynamic modulus of elasticity; K_e = horizontal stiffness at 100% strain) are summed up in Table 1. All these quantities meet the requirements of the new Italian seismic Standards [OPCM-3431 2005] for base isolated buildings, except for S_2 , which is slightly below the relevant lower limit (2.5 instead of 3). However, it should be considered that some exceptions are normally permitted for the base isolation systems of single structural or non-structural members, with respect to the limitations imposed to whole buildings.

A detailed transversal section of the floor in proximity to a HDRB is offered in Figure 11. The groove introduced in the perimeter walls is aimed at offsetting the maximum floor displacements evaluated by the non-linear design analyses discussed in the next sections. The design of the protection system was aimed at reaching a vibration period of 2.5 s in isolated conditions. The equivalent viscous damping of the HDRB devices is equal to 10%.

Table 1. Geometrical and mechanical parameters of the HDRB devices

H	206 mm
D	300 mm
t_e	120 mm
t_i	5.0 mm
t_s	2.0 mm
n_1	24
S_1	15
S_2	2.5
G_{dyn}	0.4 N/mm ²
K_e	95.5 N/mm

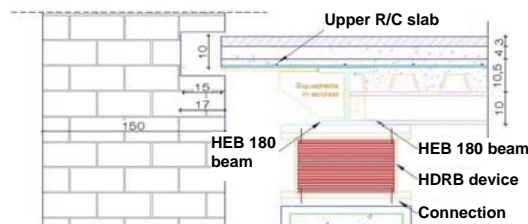

Figure 11. Transversal section of the ground floor in correspondence with a HDRB

The steel-Teflon bearings act as pure sliders, with very low dynamic friction damping (below 2%, for the normal pressures acting in this case study). They are composed of a bottom steel plate, a 5 mm thick lubricated Teflon disk, and a top steel plate, interfacing the Teflon disk by means of a 2 mm thick austenitic steel plate with a mirror finish. Further information on the mechanical properties and the experimental characterization of this type of sliders can be found in (Sorace and Terenzi 2005).

COMPUTATIONAL MODELS OF THE BASE ISOLATED FLOOR AND THE BORNE STATUES

The computational model of the base isolated floor, generated by the commercial program SAP2000NL (CSI 2007), is shown in the left graph in Figure 12 where the positions of the four HDRB isolators are highlighted with small circles. The figure also illustrates the finite element model of one of the two twin statues to be placed on the floor, whose mesh overlaps the available digital survey of their surfaces. The pedestals are connected to the floor by four pairs of monolateral sliders (i.e., reacting only under compression), which are also highlighted in the right picture in Figure 12. These elements are introduced to simulate the rocking effects that may affect the response of the statues and their bases, beyond a certain input acceleration. This model also allows reproducing the rocking-induced horizontal displacements, in addition to the vertical displacements already accounted for by the simplified model formulated in (Sorace and Terenzi 2007), incorporating “gap” elements along the perimeter of the pedestals. The finite element assemblage sketched in Figure 13 was adopted to model the response of the HDRB devices. It consists of two “gap”, two “hook” and one “plastic Wen” non-linear link elements placed in parallel, which generate the typical four-branch hyper-elastic characteristic curve of rubber bearings. The steel-Teflon sliders were modelled by the same type of links introduced at the pedestal-floor interface, whose response is governed by the

Coulomb friction law. The calibration of the relevant friction coefficient as a function of normal pressure and velocity, is discussed in (Sorace and Terenzi 2005).

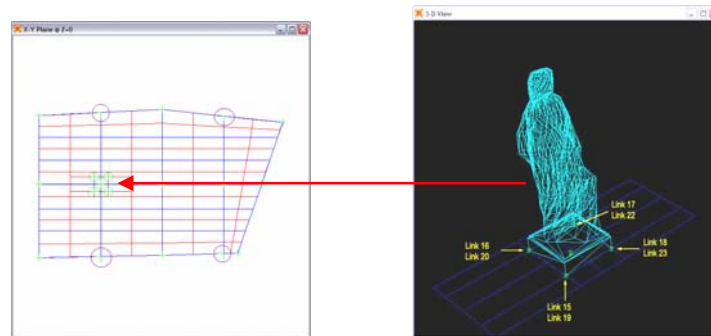

Figure 12. Computational models of the ground floor and one of the statues

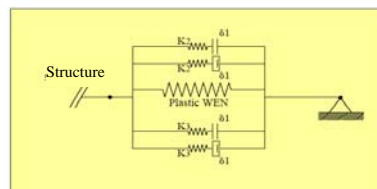

Figure 13. Finite element model of the HDRB devices

SEISMIC PERFORMANCE LEVELS FORMULATED FOR THE RESPONSE OF THE STATUES

Special evaluation criteria should be adopted when assessing the seismic response of art objects. Three special limit states are postulated in this study for marble statues, as the ones considered in this design, attested by the attainment of rocking, damage, and collapse conditions.

The first limit, which corresponds to a neat rocking-affected response (not merely the decompression of the pedestal-floor links), is characterized by a potentially unstable configuration of the pedestal. Furthermore, a remarkable amplification of the acceleration of the statue, as compared to the absence of rocking action, is observed. However, the statue still remains substantially undamaged (only some minor cracks are observed). A remedy against rocking could consist in anchoring the pedestal to the floor, but this solution can be intrusive and detrimental to the artistic value of the pedestal itself, and is generally unacceptable from an aesthetical viewpoint. The damage limit state is determined by the presence of cracks with depth no greater than half the width of the most critical section(s). Finally, the collapse limit state coincides with a total loss of strength and stability of the statue.

NON-LINEAR DYNAMIC DESIGN ANALYSES

The castle is situated in seismic zone 1, according to the current classification of the Italian territory, characterised by a reference peak ground acceleration (PGA) of 0.35 g for the basic design earthquake (BDE, having 10% probability of being exceeded over 50 years). Moreover, due to the postulated use as a museum, a magnifying protection coefficient equal to 1.2 must be adopted. Then, a value of 0.42 g is introduced as resulting input PGA in

calculations for the BDE. A non-linear dynamic approach was adopted for the design analysis of the base isolated floor. Five artificial accelerograms generated from the response spectrum of the Italian seismic Standards (OPCM-3431 2005) were assumed as basic input. Five ground motion records derived from the main shock of the 1976 earthquake, scaled at the same modified PGA of the BDE, were used to check the system performance in more detail. As a general result of this additional enquiry, the response to the historical records was always lower than the one induced by the artificial signals.

A synthesis of the analyses carried out at the BDE level is offered in Figure 14, where the response acceleration time-histories obtained from the most demanding of the five artificial accelerograms, for the ground floor and the top of one of the two statues, in base isolated and fixed base conditions, are plotted for the X and Y reference axes in plan.

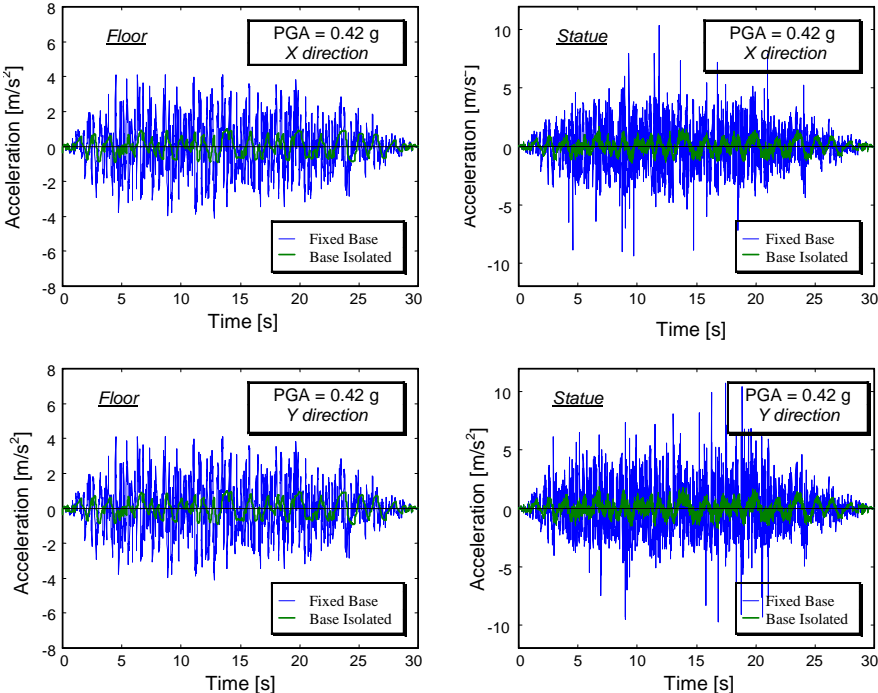

Figure 14. Acceleration time-histories of the floor and a statue in fixed base and base isolated conditions, for the BDE (X and Y direction)

Similar results are observed for the two directions, with slightly greater acceleration peaks for the Y axis. By referring to it, the benefits induced by the protection system are expressed by a fall in maximum accelerations equal to 4.16 for the floor (0.99 m/s^2 instead of 4.12 m/s^2), and 6.26 for the statue (1.72 m/s^2 instead of 10.76 m/s^2), when passing from fixed base to base isolated conditions. As a consequence of these acceleration levels, the statues overcome the rocking and even the damage limit states, in unprotected configuration, whereas they are far below rocking in the presence of the isolation system, as commented with more details in the next section.

PERFORMANCE ASSESSMENT OF THE BASE ISOLATION SYSTEM VIA INCREMENTAL DYNAMIC ANALYSIS

The response of the statues was further assessed by an incremental dynamic analysis where the PGA of the input accelerograms was progressively increased, so as to precisely locate the values corresponding to the attainment of the three postulated limit states. The rocking state

was evaluated by examining the acceleration response of the top of the statues, whereas the damage and collapse states were surveyed by monitoring the stress levels in the most vulnerable section, represented by the neck. The results are recapitulated in Table 2 for the Y direction, highlighting amplification factors ranging from 3.28 (rocking) to 4.51 (collapse) on the corresponding PGA values, for base isolated conditions, as compared to the fixed base solution. Concerning the latter, the rocking and damage-related PGAs, equal to 0.25 g and 0.371 g, are below the BDE peak acceleration, confirming the observations in the previous section. At the same time, in the presence of the base isolation, the PGA values causing the attainment of at least the lowest limit state, represented by rocking, are far beyond the amplitude of a maximum feasible earthquake for the seismic zone and the site of the castle.

Table 2. PGA, floor and statue acceleration values corresponding to the attainment of the three reference limit states

		Base Isolated	Fixed Base
Rocking limit state	PGA	0.821 g	0.250 g
	Floor acceleration	0.287 g	0.250 g
	Statue acceleration	0.417 g	0.432 g
Damage limit state	PGA	1.142 g	0.371 g
	Floor acceleration	0.630 g	0.371 g
	Statue acceleration	0.762 g	0.74 g
Collapse limit state	PGA	2.676 g	0.560 g
	Floor acceleration	2.523 g	0.560 g
	Statue acceleration	2.643 g	2.575 g

As way of example of the results of the incremental dynamic analysis, the acceleration response time-histories of the floor and a statue obtained from the most demanding artificial accelerogram, at the rocking limit state, are displayed in Figure 15, for the Y direction.

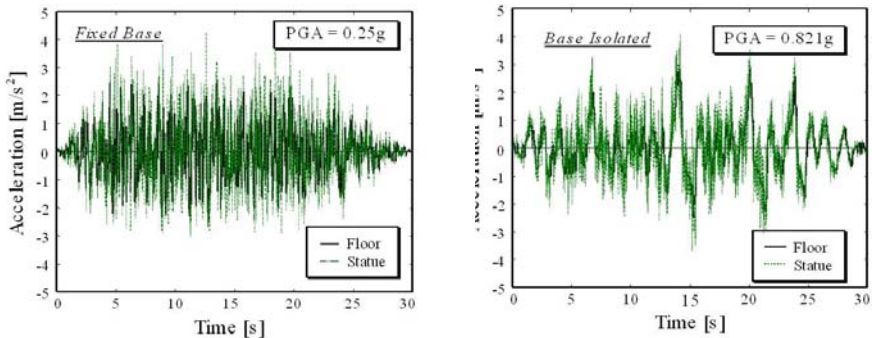

Figure 15. Acceleration time-histories of the floor and a statue in fixed base and base isolated conditions, at the rocking limit state (Y direction)

The corresponding distributions of the normal stress components relevant to the second local axis of the elements of the mesh, which nearly coincide with the vertical axis of the global reference system, are displayed in Figure 16 for the base isolated configuration (similar distributions are obtained in fixed base conditions, for a PGA of 0.25 g, instead of 0.821 g, as reported in Table 2). The maximum tensile stress values in the neck, as well as in the remaining parts of the statue, are lower than the tensile strength of the constituting marble,

approximately equal to 1 MPa. This confirms that, for this case study, the attainment of the rocking limit state does not cause significant damages in the statues, which are deferred to around 50% greater acceleration levels (0.371 g, instead of 0.25 g – fixed base; 1.142 g, instead of 0.821 g – base isolated).

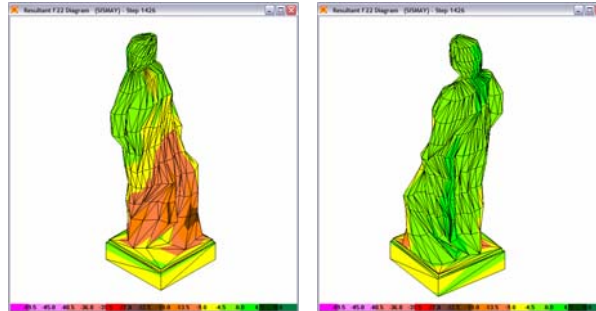

Figure 16. Normal stress distributions relevant to the second local axis of the elements of the mesh, corresponding to the rocking limit state, in base isolated conditions

CONCLUDING REMARKS

The redesign hypothesis of the Prampero castle presented herein was aimed at showing the possibility of combining traditional updated rebuilding techniques, for masonry walls and wooden floors, and advanced seismic protection strategies, for the ground floor of the main exhibition spaces of the building. In particular, a novel solution was proposed for this floor, since base isolation of single statues and artistic objects, rather than of an entire bearing floor, have been generally proposed for museum buildings. The simple and low-cost base isolation system adopted in this design allows reaching totally safe response conditions for the borne statues, also under the action of a maximum feasible earthquake for the seismic zone and the site of the castle. These results prompt the use of this solution for wider applications in the field of seismic protection of art exhibits in museum halls situated on the ground floor.

ACKNOWLEDGEMENTS

The study reported in this paper was financed by the Italian Department of Civil Protection within the Reluis-DPC Project 2005/2008. The authors gratefully acknowledge this financial support.

REFERENCES

- CSI, “SAP2000NL. Structural Analysis Programs - Theoretical and Users Manual”, Version No. 10.14, CSI, Berkeley, CA, 2007.
- OPCM-3431, “Norme tecniche per il progetto, la valutazione e l’adeguamento sismico degli edifici”, G.U., Rome, Italy, 3 May, 2005.
- Sorace S., Terenzi G., “Application of a combined base isolation/supplemental damping seismic protection strategy to a public building in Florence”, *Proc. International Conference “250th Anniversary of the 1755 Lisbon Earthquake”*, Lisbon, November, 2005, pp. 481-486.
- Sorace S., Terenzi G., “Rebuilding of an ancient castle including a base-isolated museum hall”, *Proc. International Conference STREMAH 2007*, Prague, July, 2007, pp. 419-428.