



UNIVERSITÀ  
DEGLI STUDI  
FIRENZE

## FLORE

# Repository istituzionale dell'Università degli Studi di Firenze

### **Analysis of Time Domain Ultra-wide-band Radar Signals Reflected by Buried Objects**

Questa è la Versione finale referata (Post print/Accepted manuscript) della seguente pubblicazione:

*Original Citation:*

Analysis of Time Domain Ultra-wide-band Radar Signals Reflected by Buried Objects / P. Falorni; L. Capineri; L. Masotti; C.G. Windsor. - In: PIERS ONLINE. - ISSN 1931-7360. - ELETTRONICO. - Vol. 3, No. 5:(2007), pp. 662-665. (Intervento presentato al convegno PIERS 2007 tenutosi a Beijing, CHINA nel 26-30 March, 2007) [10.2529/PIERS061004063107].

*Availability:*

This version is available at: 2158/362034 since: 2019-07-25T17:53:26Z

*Publisher:*

PIERS

*Published version:*

DOI: 10.2529/PIERS061004063107

*Terms of use:*

Open Access

La pubblicazione è resa disponibile sotto le norme e i termini della licenza di deposito, secondo quanto stabilito dalla Policy per l'accesso aperto dell'Università degli Studi di Firenze (<https://www.sba.unifi.it/upload/policy-oa-2016-1.pdf>)

*Publisher copyright claim:*

(Article begins on next page)

# Analysis of Time Domain Ultra-Wide-Band Radar Signals Reflected by Buried Objects

P. Falorni<sup>1</sup>, L. Capineri<sup>1</sup>, L. Masotti<sup>1</sup>, and C. G. Windsor<sup>2</sup>

<sup>1</sup>Laboratorio Ultrasuoni e Controlli Non Distruttivi, Dipartimento Elettronica e Telecomunicazioni  
Università di Firenze, 50139 Firenze, Italy

<sup>2</sup>116, New Road, East Hagbourne, OX11 9LD, UK

**Abstract**— The aim of this work is the analysis of the signal composition observed in a single radar sweep during an underground investigation with an ultra-wide-band (UWB) radar. The electromagnetic (EM) response of a buried object, the radar pulse spectrum and the antenna set-up, all strongly influence the accuracy of the time of flight estimate. The analysis of the time domain signal will discuss the effects of the antenna coupling with the ground (first arrival pulse from air-soil interface) and the interference of overlapping pulses due to multiple interfaces and multiple reflections. The results of this analysis are based on simulations with parameters characteristic of an investigation of layered medium and signal processing schemes to extract information about soil and buried objects composition will be addressed.

DOI: 10.2529/PIERS061004063107

## 1. INTRODUCTION

The aim of this work is the analysis of the signal composition observed in a single radar sweep during an underground investigation with an UWB radar. The electromagnetic response of a buried object, the radar pulse spectrum and the antenna set-up, all strongly influence the accuracy of the time of flight estimate. The analysis of the time domain signal will discuss the effects of the antenna coupling with the ground (first arrival pulse from air-soil interface) and the interference of overlapping pulses due to multiple interfaces and multiple reflections. The electromagnetic response of this experimental configuration has been already described in previous works (e.g., Dai and Young in [1]). In many practical cases the experimental conditions can be assumed for a linear response and therefore the time domain signals are generated by time convolution between the transmitted current pulse and the characteristic response of the layered medium [7].

In this work the effects described above have been simulated and illustrated by computer modeling. The assumed model considers the propagation in a layered soil and transmitting-receiving antenna placed at different positions above the ground surface. Losses in the medium have been also considered by the complex dielectric constant and multiple reflections in each layer are calculated recursively.

## 2. ELECTROMAGNETIC MODELING OF LAYERED MEDIA

The adopted model considers a layered media where the layers are defined by their electromagnetic properties — i. e., relative dielectric constant  $\epsilon_R$ , magnetic permeability  $\mu_R$  conductivity  $\sigma$  — and thickness  $d$ . The simple mono-dimensional model assumes a source generating a plane wave with assigned spectrum ( $E$ ) and placed in a given layer and a receiving antenna placed in a layer that can also be the same of the transmitter.

In each layer it is assumed that the transversal component of the electric field is due to the contribution of the components from the two adjacent layers plus the eventually present transmitting source. Outer layers of the model should be defined as semi-infinite. The calculated solution for the received signal is obtained by a recursive process that returns the EM field spectrum at the receiving antenna position. Inverse Fourier transform is then applied to the received spectrum for obtaining the time domain signal.

At each run, the recursive function propagates the EM field into current layer, than recall itself to propagate the EM field through next layer and into current layer but in the opposite direction. The returned EM field at the antenna position is summed to its current value and returned to the caller function.

The recursion stops if executed into a semi-infinite layer — because no further back-propagation can occur — or if the energy carried by the EM field is lower than a predefined signal-to-noise ratio of the receiving antenna. If the current layer contains the receiving antenna, the recursive function evaluates the EM field at the antenna position and uses it as return value for the caller.

With reference to Figure 1, let assume that the EM field is propagating into layer  $K$  in the FORW direction; the recursive function propagates the EM field through layer  $K$ , than:

- Evaluates the EM field transmitted into layer  $K + 1$  (EM-FORW) than recall itself to process layer  $K + 1$  in the FORW direction using EM-FORW as starting value.
- Evaluates the EM field reflected into layer  $K$  (EM-BACKW) than recall itself to process layer  $K$  in the BACKW direction using EM-BACKW as starting value.

At each run the recursive function checks the stop conditions and, if necessary, calculates the EM field at the receiving antenna position.

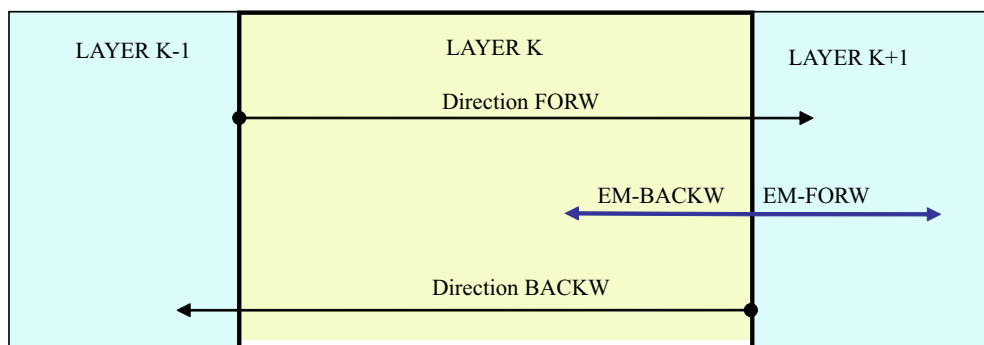

Figure 1: Electromagnetic model of layered media based on the recursive calculation of the propagating electric field.

The electromagnetic modeling has been used to generate the signal shown in Figure 2. A propagation medium composed of a 0.26 m thick layer of sand in air, monostatic antenna placed in air at 0.5 m from the sand ( $\epsilon_R = 3$ ,  $\mu_R = 1$ ,  $\sigma = 7 \times 10^{-3} (\Omega\text{m})^{-1}$ ) layer. The dashed line is the transmitted pulse with central frequency  $f_{\text{central}} = 550$  MHz and  $-3$  dB bandwidth of 650 MHz. The solid line is the time domain received signal. The simulation is carried out without superimposed noise on amplitude samples. The sampling frequency used is 6 GHz and the number of time samples is 121; the transmitted pulse has been delayed by 4 ns and the radar acquisition system is configured with a signal to noise ratio of 100 dB. The aliasing in the time domain has been removed setting to zero all the frequency samples having a total delay greater than the simulation time window.

### 3. ANALYSIS OF PULSE RESPONSE FOR TIME-OF-FLIGHT ESTIMATION

Recalling that the time-of-flight ( $tof$ ) for an homogenous layer with propagation velocity  $V$  and thickness  $d$  is defined by:  $tof = 2d/V$ , the main issue for  $tof$  estimation is the finite duration of the transmitted pulse.

The finite duration of the probing pulse introduces an uncertainty because the direct estimate (time differences) deals with wavelets instead of delta functions.

The estimation of  $tof$  could be also carried out by using correlation techniques operating on the “mainbang” (first large amplitude reflection from air-soil interface) and the target signal; these methods do not give accurate results mainly because the two signals have been differently modified during propagation. Several works have been published in order to get an accurate estimation of the time domain response by EM modelling of the GPR experiments [1, 6]. The phenomena that modify the transmitted pulse are the propagation characteristics of the layer and overlapping wavelets due to close (comparable to wavelength) interfaces. Furthermore, in the case of a bistatic antenna in contact with soil, the “mainbang” signal is the summation of two signals, one propagating in air and the other propagating into soil [1].

This situation, in general leads to a different shape for the “mainbang” with respect to the signals reflected by a planar target. Hence the “mainbang” is not a good template for accurate  $tof$  estimation with correlation methods. A possible approach investigated here is the signal homomorphic deconvolution [5] applied to the summation between a reference signal  $r(t)$  and the received

signal  $s(t)$ . Using a bi-static antenna, the measurement of the reference signal can be obtained with the free space response, taking care to avoid saturation phenomena during the analog to digital conversion.

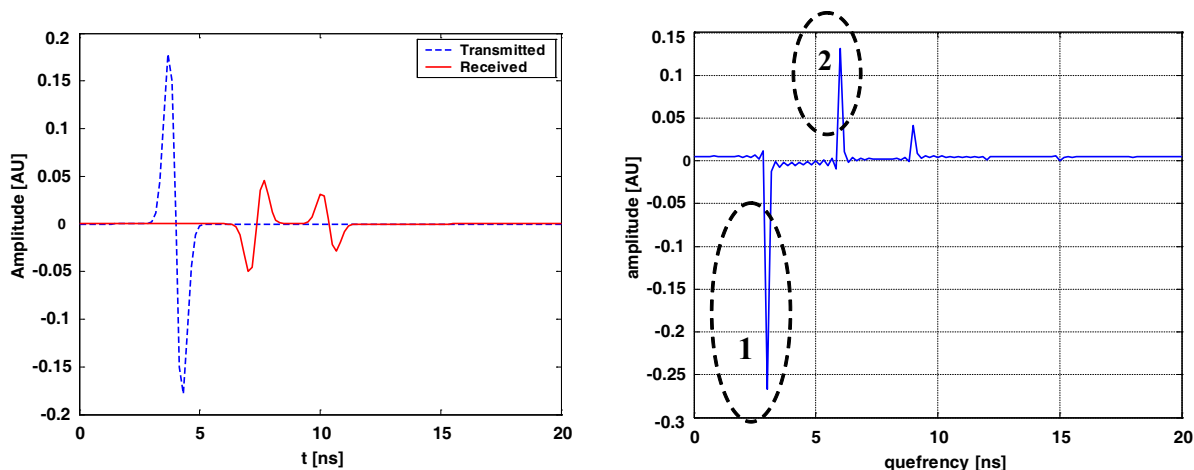

Figure 2: (LEFT) Simulation of the received signals for a propagation medium composed by a 0.26 m thick layer of sand in air, monostatic antenna placed in air at 0.5 m from the sand ( $\epsilon_r = 3$ ,  $\mu_r = 1$ ,  $\sigma = 7 \times 10^{-3} (\Omega\text{m})^{-1}$ ) layer. Dashed line: the transmitted Gaussian pulse with central frequency equal to 550 MHz and  $-3$  dB bandwidth of 650 MHz. Solid line: time domain received signal. The simulation is carried out without any superimposed noise on amplitude samples. (RIGHT) Application of the signal deconvolution (CEPSTRUM method) based on a reference signal. Time difference between the two delta-like functions 1 and 2 corresponds to the time of flight relative to the path inside the sand layer. The estimated time of flight is 3 ns which corresponds to 0.259 m of sand layer thickness.

In this work we study the possibility of using the reference signal  $r(t)$  to overcome the problems due to the ill-conditioned features in the transformed space, named *cepstral* domain or *quefrequency* domain. In Figure 2 (RIGHT) it is shown the result of applying the deconvolution method to a simulated radar trace and a reference signal for a simple monostatic antenna setup: the time of flight for the pulse propagating into the 0.26 m thick sand layer can be directly evaluated from the time difference of the peaks 1 and 2 of Figure 2 (RIGHT).

Instead, using a bi-static antenna setup — e.g., with a gap between transmitting and receiving antenna of 0.2 m — for a radar scanning in contact with the ground, we obtain two peaks (Figure 3) related to the “mainbang”; these signals are due to the existence of a double path for direct coupling of transmitting and receiving antenna, one path in air and the other into ground (i.e., for the case of Figure 3, sand). The time difference  $t_D$  between the two peaks can also be used to evaluate sand propagation velocity.

Furthermore, it can be seen in Figure 3 (LEFT) that the received signal is different from the transmitted pulse; in this case, the method was able to separate the *AIR* and *SOIL* signals even for a time delay  $t_D$  that is significantly lesser than the pulse duration.

#### 4. AN APPLICATION OF TIME-OF-FLIGHT ESTIMATION TO BURIED OBJECT CHARACTERIZATION

The depth, lateral position and radius of a large buried pipe in a soil with unknown propagation velocity is a challenging problem that can be solved with signal processing methods based on the time-of-flight hyperbolic equation [2–4]:

$$t\hat{o}f_i = tof_i + t_{MB} = \frac{2}{V} \left( \sqrt{(y_i - Y_0)^2 + Z_0^2} - R \right) + t_{MB} \quad (1)$$

where  $Y_0$ ,  $Z_0$  are the coordinate of the pipe centre,  $R$  is the pipe radius ( $R > \lambda_{\text{central}} = V/f_{\text{central}}$ ),  $V$  is the medium propagation velocity;  $tof_i$  is the time-of-flight measured at the lateral position  $y_i$  of a monostatic antenna. According to the analysis of the inversion of the Equation (1) [8], the estimation of the unknown parameters is strongly affected by errors in the  $tof$  estimation.

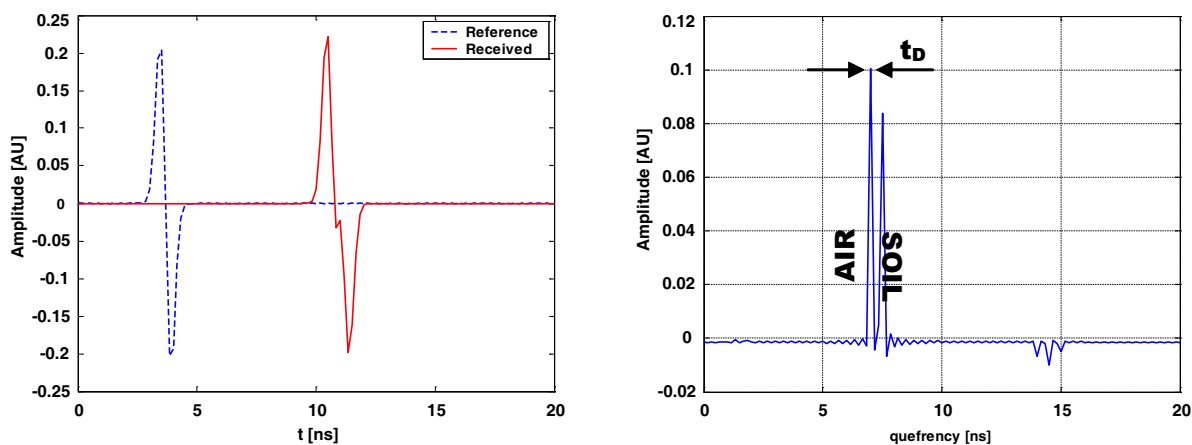

Figure 3: (LEFT) Simulation of the received signal from an infinite layer of sand using an in contact scanning with an UWB radar configured in bistatic mode (0.2 m TX-RX separation). The characteristics of radar and medium are the same as in Figure 2. (RIGHT) The application of the signal deconvolution (CEPSTRUM method) shows two peaks related to the “mainbang”; the first peak corresponds to a wave propagating in the 0.2 m air gap and the second peak corresponds to a wave propagating in the 0.2 m sand gap.

Moreover, the uncertainty on the estimation of the term  $t_{MB}$ , which represents the delay time of the “mainbang” signal, directly reflects on the  $tof_i$

With the deconvolution method the estimation of the  $tof_i$  is straightforward and avoids the problem of estimating  $t_{MB}$ , which is rather cumbersome even with instrument calibration procedures; anyway its accuracy is limited by the finite pulse duration.

#### REFERENCES

1. Dai, R. and C. T. Young, “Transient fields of a horizontal electric dipole on a multilayered dielectric medium,” *IEEE Trans. on Ant. And Prop.*, Vol. 45, No. 6, 1023–1031, June 1997.
2. Falorni, P., L. Capineri, L. Masotti, and G. Pinelli, “3-D radar imaging of buried utilities by features estimation of hyperbolic diffraction patterns in radar scans,” *Tenth International Conference on Ground Penetrating Radar*, Delft, The Netherlands, 21–24 June, 2004.
3. Grandjean, G., J. C. Gourry, and A. Bitri, “Evaluation of GPR techniques for civil-engineering applications: study on a test site,” *Journal of Applied Geophysics*, Vol. 45, 141–156, 2000.
4. Shihab, S., W. Al-Nuaimy, and A. Eriksen. “Radius estimation for subsurface cylindrical objects detected by ground penetrating radar,” *Tenth Intern. Conference on Ground Penetrating Radar*, 319–322, Delft, The Netherlands, June 21–24, 2004.
5. Oppenheim, A. V., R. W. Shafer, and T. G. Stockham, “Non linear filtering of multiplied and convolved signals,” *Proceedings of the IEEE*, Vol. 56, No. 8, 1264–1291, 1968.
6. Van der Kruk, J., E. C. Slob, and J. T. Fokkema, “Background of ground-penetrating radar measurements,” *Geologie en Mijnbouw*, Vol. 77, 177–188, 1999.
7. Fokkema J. T., “Analysis of georadar reflection responses,” *2nd Intern. Workshop on Advanced GPR*, 1–4, Delft, The Netherlands, 14–16 May, 2003.
8. Windsor, C., L. Capineri, P. Falorni, S. Matucci, and G. Borgioli, “The estimation of buried pipe diameters using ground penetrating radar,” *Insight*, Vol. 47, No. 7, 394–399, July 2005.