



UNIVERSITÀ
DEGLI STUDI
FIRENZE

FLORE

Repository istituzionale dell'Università degli Studi di Firenze

Strontium optical-atomic-clock

Questa è la Versione finale referata (Post print/Accepted manuscript) della seguente pubblicazione:

Original Citation:

Strontium optical-atomic-clock / N. Poli; R. E. Drullinger; G. Ferrari; M. Prevedelli; F. Sorrentino; G. M. Tino. - ELETTRONICO. - (2005), pp. 0-0. (Intervento presentato al convegno Proceedings of the 1st ESA International Workshop on Optical Clocks tenutosi a ESTEC , Noordwijk, The Netherlands nel 8-10 June 2005).

Availability:

The webpage <https://hdl.handle.net/2158/776518> of the repository was last updated on

Publisher:

European Space Agency (ESA), ESTEC , Noordwijk, The Netherlands

Terms of use:

Open Access

La pubblicazione è resa disponibile sotto le norme e i termini della licenza di deposito, secondo quanto stabilito dalla Policy per l'accesso aperto dell'Università degli Studi di Firenze (<https://www.sba.unifi.it/upload/policy-oa-2016-1.pdf>)

Publisher copyright claim:

La data sopra indicata si riferisce all'ultimo aggiornamento della scheda del Repository FloRe - The above-mentioned date refers to the last update of the record in the Institutional Repository FloRe

(Article begins on next page)

Strontium optical-atomic-clock

N. Poli¹, R.E. Drullinger¹, G. Ferrari¹, M. Prevedelli², F. Sorrentino¹ and G. M. Tino¹

⁽¹⁾*Dipartimento di Fisica and LENS, Università di Firenze,*

Via dello Carrara 1, 50019 Sesto Fiorentino, Italy

⁽²⁾*Dipartimento di Chimica Fisica, Università di Bologna, Via del Risorgimento 4, 40136 Bologna, Italy*

E-mail: poli@lens.unifi.it, Guglielmo.Tino@fi.infn.it

(Dated: September 16, 2005)

We report on our progress toward the realization of an optical frequency standard referenced to strontium intercombination lines. First we directly measured the frequency of the visible $5s^2\ ^1S_0 - 5s5p\ ^3P_1$ intercombination line in an atomic beam, using a GPS referenced optical frequency comb. The values measured for the two most abundant isotopes are 434 829 121 311 (10) kHz for ^{88}Sr and 434 828 957 494 (10) kHz for ^{86}Sr . To improve the stability and accuracy of the lock to the atomic line, we prepared an ultracold sample of Sr atoms. The atoms are slowed and trapped on the allowed $5s^2\ ^1S_0 - 5s5p\ ^1P_1$ transition, and a second cooling stage is applied on the $5s^2\ ^1S_0 - 5s5p\ ^3P_1$ intercombination line finally obtaining more than 10^6 ^{88}Sr atoms at less than $1\ \mu\text{K}$. The cold atoms are then transferred into a pure optical dipole trap at the “magic” wavelength for the $5s^2\ ^1S_0 - 5s5p\ ^3P_1$ transition.

I. INTRODUCTION

Strontium has become the object of much recent study in atomic physics ranging from cold collisions [1] to multiple scattering [2] and frequency metrology [3]. The level scheme (see Fig. 1) gives the possibility to directly cool strontium with standard Doppler cooling techniques to temperature well below $1\ \mu\text{K}$ in hundreds of ms. Thanks to the ultra-narrow intercombination transitions, strontium is the object of intense study in the field of frequency metrology. These studies open the way to the realization of a new optical frequency standard with unprecedented stability and accuracy. Proposals based on different interrogation schemes have been put forward (optical lattice clock [4], free falling atoms [5], engineered atom clock [6, 7]) suggesting the possibility to reach the 10^{-17} level of overall accuracy. Indeed, thanks to the higher oscillator frequency, a clock in the optical domain could potentially reach a stability level of 10^{-18} at 1 s [4] which represents a factor of 10^4 better with respect to the best microwave standards [8]. A clock with such a level of stability and accuracy could be used as a powerful test for relativistic theory, searching for deviation of fine structure constant, and more fundamentally to define a new atomic time standard. Such a clock could open the way to a wide range of applications such as deep space navigation, remote sensing, secure telecommunications and ultra-precise geodesy.

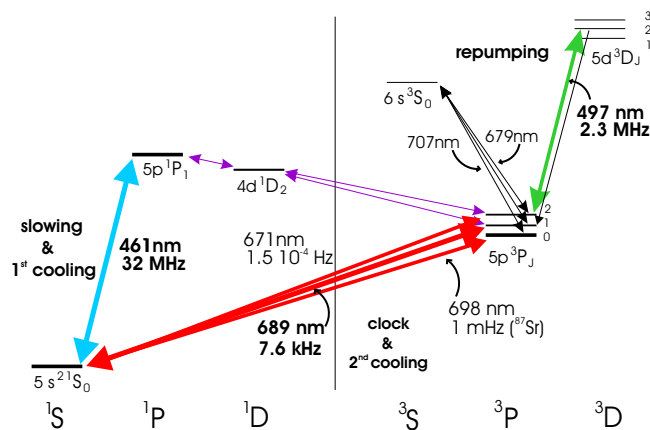

FIG. 1: *Simplified energy levels and optical transition for strontium.*

Two different kinds of atomic systems are under study for the realization of more accurate and stable optical frequency standards: single ions and neutral atoms. The idea first proposed by Katori [3] of the so called optical lattice clock could realize the two main advantages of using optical transitions as a quantum reference: good short term stability resulting from the large number of atoms as quantum absorber ($> 10^6$) and high accuracy, through the control of the wavelength used for trapping the atoms. Such a dipole trap in fact could not only

eliminate the mechanical effect of the light on the atoms, but also limit the AC Stark shift due to the trap light itself. This kind of interrogation scheme is now successfully employed with very promising results [4, 9].

At present, our work is progressing along two parallel avenues; 1) trapping and cooling of strontium and 2) working toward a suitable local oscillator for an optical clock based on optical intercombination transitions of strontium.

II. STABLE LASER AT 689 NM

The scheme of our stable master source resonant with the intercombination 1S_0 - 3P_1 transition for the bosonic strontium isotope is reported in Fig. 2. The master laser is a commercial 689 nm diode laser mounted in

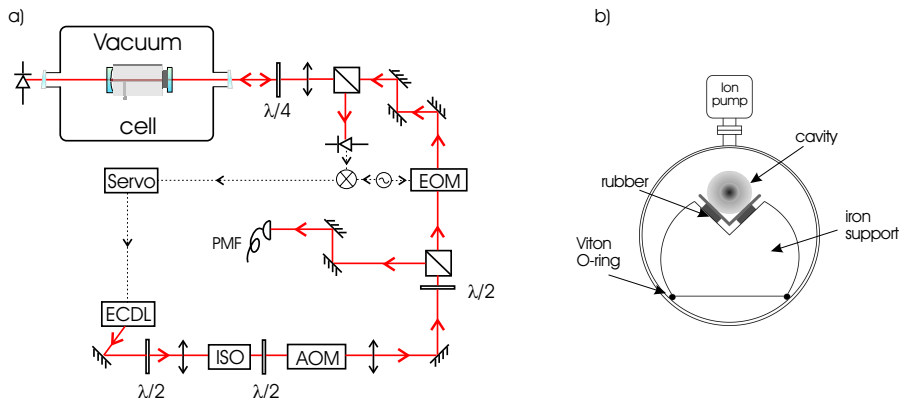

FIG. 2: a) Experimental setup for the stable 689 nm laser, ECDL: extended cavity diode laser, AOM: acousto-optic modulator, ISO: 30 dB optical isolator, EOM: electro optic modulator, PMF: polarization maintaining fiber. b) Detail of the cavity suspension; the diameter of the outside cell is 20 cm.

extended cavity configuration (Littrow). The reduction of the fast linewidth is realized by locking the laser to a resonance of a reference cavity with standard Pound-Drever-Hall technique. The laser electric field is phase modulated at 11 MHz with a EOM (Linios) with a modulation index $m = 1$, while the error signal is derived by demodulating the light signal reflected from the cavity. In order to reduce the feedback light from the cavity going back to the laser, we use an optical isolator and an AOM in cascade at the output of the laser which give an attenuation of 80 dB.

The cavity is composed of a 10 cm quartz spacer to which are attached the two mirrors ($R=0.9995$ at 689 nm) one is flat and the other has a radius of curvature of 50 cm. The cavity stands on a massive iron V-block (20 kg approx.) and is horizontally aligned. The vacuum chamber that contains the cavity and the iron block is evacuated (10^{-6} Pa) and the vacuum is maintained with a 2 l/s ion pump. In order to attenuate vibration from the optical table induced into the cavity, pieces of Viton O-ring and rubber are used between the cavity and the iron and between the iron and the vacuum cell. The optical table is also supported with a passive air damping system.

The reflected light from the cavity is collected with a Si photodiode (Hamamatsu S5832-811), amplified with a fast and low current noise transimpedance amplifier (Philips NE5210) and finally down-converted with a mixer (Minicircuits TSM-3). The level of the voltage noise at the output of the detector is -110 dBV/ $\sqrt{\text{Hz}}$ which corresponds to the shot noise of 100 μW of incident light. The cavity resonance has a FWHM of 170 kHz. In that condition the slope of the error signal is 3.4 V/MHz. The error signal has then $S/N \sim 200$ on a bandwidth of 3 MHz. The error signal for locking the laser to the cavity is then sent to the laser via three channels: 1) to the PZT of the external cavity of the laser with a bandwidth up to 2 kHz, 2) to the laser current driver with a bandwidth up to 50 kHz, 3) directly to the diode with a bandwidth up to 3 MHz.

The signal to noise ratio in our case would be sufficient to achieve laser linewidth of less than 1 Hz. Actually the laser linewidth is limited by noise induced in the cavity (mainly acoustic and sub-acoustic vibration) which is then transferred as frequency fluctuations directly to the laser. By using a resonance mode of a second cavity as a frequency discriminator, we could determine the absolute frequency noise of our master laser. This cavity has the same geometry of the first cavity, it stands on the same optical table but is aligned perpendicular with

respect to the first cavity. The measurements are reported in Fig. 3 respectively for laser unlocked, laser locked to the cavity, and laser locked to the cavity with the passive damping working.

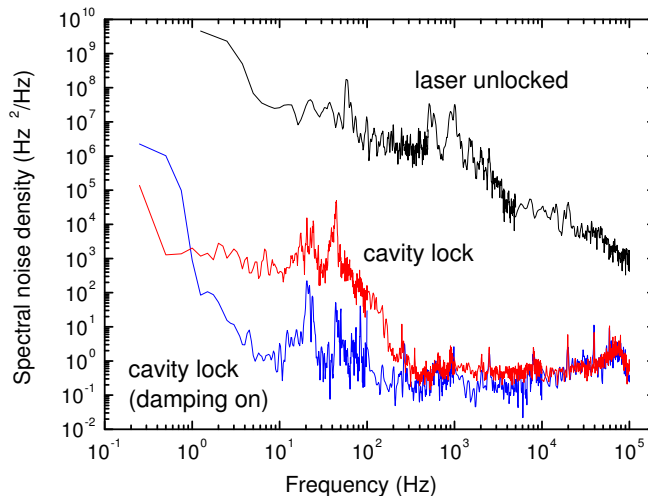

FIG. 3: Frequency noise of the laser locked to the cavity. From the lower line we can infer a laser linewidth of about 20 Hz.

From the integrated noise measured on the second cavity we can infer a fast linewidth $\Delta\nu \sim 20$ Hz, mainly limited by some excess noise peaked around 20 Hz and 40 Hz. These two peaks are due to our noisy laboratory. One possible source could be environmental noise coming from compressors used for cooling the lab, which is then not completely attenuated by the damping system of the optical table. While the resulting laser linewidth is sufficiently narrow for doing spectroscopy on the broad 1S_0 - 3P_1 line for ^{88}Sr , for spectroscopy on ultra-narrow strontium transitions, we are setting up a second stage of stabilization to a higher finesse cavity sustained with a better isolation from acoustic noise [10].

For the long term stability of the laser we actively stabilize the length of the reference cavity with a lock to an atomic signal (thermal beam, heatpipe). For this purpose we use a PZT transducer (Noliac) for tuning the cavity length (PZT sensitivity 38 MHz/V). In order to reduce electronic noise induced by the PZT, two different voltages are applied to the two side of the PZT transducer: the first for coarse tuning of the cavity (up to 2 GHz) comes from a battery while the small cavity length correction (up to 2 MHz) are delivered from low noise electronics.

The overall system (master laser, vacuum cell and optics) is quite compact and it fits on a single 60 cm \times 60 cm aluminium breadboard.

III. ABSOLUTE FREQUENCY MEASUREMENT

In our first work we have used a fs-optical-comb-generator to make absolute frequency measurements of the 1S_0 - 3P_1 transition at 689 nm. Details of the experimental apparatus can also be found in [11, 12]. Part of the light coming from the pre-stabilized 689 nm source is coupled into a polarization maintaining fiber and delivered to a strontium thermal atomic beam, while a second light beam is sent towards the comb with a 20 m fiber. With standard saturation spectroscopy techniques we obtained a sub-Doppler signal used for long term stabilization of the length of the cavity. The values measured for the two most abundant isotopes are 434 829 121 311 (10) kHz for ^{88}Sr and 434 828 957 494 (10) kHz for ^{86}Sr which has been derived by difference from the measurement of the ^{88}Sr - ^{86}Sr isotopic shift (163 817.4 (0.2) kHz).

In the absolute frequency measurement one of the main limitation to the accuracy was found to be an instability of our GPS referenced quartz used as an LO for the comb. This limitation was clearly shown by making a direct comparison of the two Allan deviations respectively for the absolute frequency measurement and the isotopic shift measurement. While for the first measurement the deviation was limited to 2 kHz (5×10^{-11})

at 100 s, in the second measurement the frequency deviation decreases as $\tau^{-1/2}$ reaching 100 Hz at 100 s (10^{-13}) (see Fig. 5 in [12]).

Through a collaboration with the time and frequency group of Galileo Ferraris-IEN in Torino our GPS based frequency reference system has now been improved with a new design of the servo loop for the BVA quartz. By locking the BVA quartz oscillator to a new rubidium clock the stability is 10^{-13} out to 10^4 s. As before the long term stability ($t > 10^4$ s) is obtained by a second stabilization loop with the GPS signal.

IV. STRONTIUM HEATPIPE

In order to obtain a better signal to noise ratio for the lock to the atoms, we recently replace the thermal beam with a strontium heatpipe. The heatpipe is made up with a 2.5 cm diameter tube with a length of 60 cm. The central part is filled with strontium pieces and is maintained at 500 °C. At both ends of the tube standard un-coated BK7 windows, glued at Brewster angle, are used to pass the probe and pump light. In order to prevent chemical attack or condensation of the strontium vapour on the window, a buffer gas (normally He or Ar) is loaded at a pressure of 7×10^{-3} mbar and the tube is water cooled on both sides at 10 cm from the hot center. The mean free path of strontium atoms in this condition is of the order of 1 cm, less than the distance to the window from the hot center, while the linewidth we expect from pressure broadening is about 50 kHz [13].

To avoid interference between probe and pump beams, the pump beam is shifted of 160 MHz with a double pass AOM, which also is used for the low frequency modulation (~ 10 kHz) of the pump beam. The two beams have similar diameter of about 1 cm and a power respectively of 200 μ W and 50 μ W. The pump beam absorption on resonance is about 10% which is compatible with the Sr atom density of 4×10^{10} cm^{-3} obtained at this temperature. The quantization axis is defined parallel to the polarization axis of the laser beams applying a magnetic field of $B \sim 10$ mT with four permanent magnets.

Probe beam light is then collected with a Si photodiode and amplified. The sub-Doppler signal obtained has a FWHM of 200 kHz mainly limited by power broadening, first-order Doppler effect due to a misalignment of the pump and probe beam, transit time broadening, and pressure broadening. This signal is then demodulated with the low frequency modulation used for the pump beam and the error signal obtained has typically a S/N ratio of 60 in a 10 Hz bandwidth. While this S/N ratio is enough in order to lock the laser to the line center with an uncertainty of 2 kHz, we are working in order to obtain a narrower lock signal.

The drift of the cavity in normal operation is of the order of 20 Hz/hour. In order to correct for this slow drift, we send the integrated error signal to the PZT of the cavity with an overall bandwidth of less than 5 Hz. In normal operation condition the dynamic range of the servo electronics assures a stable lock for about a day.

V. COOLING AND TRAPPING STRONTIUM

The trapping/cooling apparatus [14] is conventional in that it starts with a thermal oven and capillary array collimator. This is followed by a zone of 2D transverse molasses, a Zeeman slower and MOT. The blue light for driving the strongly allowed $^1\text{S}_0$ - $^1\text{P}_1$ transition comes from a 922 nm semiconductor device (DFB + tapered amplifier) frequency doubled in a cavity enhanced PPKTP crystal [12]. It is frequency referenced to a saturated absorption feature in a second Sr heatpipe. With the addition of a repumper at 497 nm (resonant with the $^3\text{P}_2$ - $^3\text{D}_2$), we are able to load 3×10^8 atoms into the MOT in 160 ms. The temperature at this stage is limited to the mK range by the strongly allowed nature of the cooling transition. After the first stage cooling, the blue MOT is switched off and the cooled atoms are recaptured into a red MOT operated on the $^1\text{S}_0$ - $^3\text{P}_1$ intersystem crossing transition at 689 nm.

A slave laser is injection-locked to the stable master ECDL is used to drive the red MOT. The red beam is overlapped to the blue beam on a dichroic mirror. From this point the two beams share the same broadband optics (mirror, cubes, waveplates) up to the atoms. The recapture process involves a 200 ms long broadband phase to capture and further cool the atoms after which they are held in a single-frequency MOT which lasts for 40 ms. During this last phase the red MOT beam intensity is decreased in order to further cool the atoms. Figure 4 presents a typical time of flight measurement of the number of atoms trapped in the red MOT and their temperature, as a function of the total MOT beam intensity. Typically we can trap 5×10^5 (4×10^6 with repumper beam) ^{88}Sr atoms at 1 μK , the maximum transfer efficiency of the atoms from the blue MOT to the red MOT is about 20%, and the minimum temperature we have reached is 350 nK.

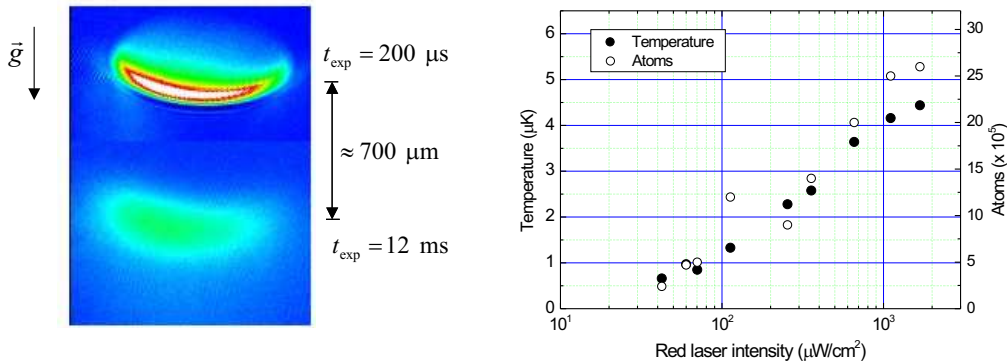

FIG. 4: Time of flight measurement of the temperature and number of ^{88}Sr atoms trapped in the red MOT as a function of the total trapping beam intensity. These data are taken without the use of the repumper light during the capture in the blue MOT.

Finally, the cloud is then transferred into a FORT realized by focusing a far detuned 922-nm laser beam on the center of the trap. At this wavelength, setting the optical-field polarization orthogonal to the magnetic field, the differential Stark shift between the $^1\text{S}_0$ and $^3\text{P}_1$ levels is small with respect to the transition linewidth, allowing precision spectroscopy and laser cooling even on optically confined atoms [15]. At this point, the density is high enough that collision physics (two body, three body and light assisted collisions) become the dominant mechanism controlling temperature, density, trapping lifetimes, etc. The combination of red MOT and various geometries of dipole trapping afford an excellent environment in which to study this important physics and we have taken advantage of this possibility [16].

With a slight modification to the loading procedure, we are able to load multiple isotopes simultaneously [14]. We first load ^{88}Sr or ^{86}Sr into the blue MOT with the repumper turned off. This has the effect of magnetically trapping the atoms in the “dark” metastable $^3\text{P}_2$ level. When the desired number of atoms has been captured, we step the blue laser to the resonance of another isotope and load them into the magnetic trap. Following this loading procedure, the blue laser is turned off and the repumper is flashed on for a few ms. This puts the atoms back in their ground state where we recapture them into the red MOT operated with two slave lasers tuned to the different isotopes. We see no deleterious effect of the mixed species on the trap operation. In this way we are able to measure most of the collisional rates (elastic and inelastic) as they relate to both inter and intra species [16]. In addition to giving us valuable information about collisional interactions that will be operational in any subsequent clock, this technique gives us additional degrees of freedom to reach higher phase space density.

VI. CONCLUSION

We have presented the experimental apparatus used for absolute frequency measurement of intercombination lines of strontium at the 10^{-13} level. The new setup also allows the possibility to trap more than 10^6 ^{88}Sr atoms below $1 \mu\text{K}$. This setup represents the first step in order to build a new optical frequency reference based on optical ultranarrow strontium lines.

The ultimate performance of an optical clock working on a the $^1\text{S}_0$ - $^3\text{P}_1$ transition for the most abundant ^{88}Sr isotope is limited by the linewidth of the transition (stability 10^{-14} at 1 s, accuracy 10^{-15} [17]). While such a clock does not represents the ultimate candidate for a new primary standard, thanks to the improved stability with respect to actual microwave standards it could be used as a secondary representation of the SI second. A recent measurement on that transition done with free falling atoms at $1 \mu\text{K}$ has already showed an accuracy of 33 Hz (8×10^{-14})[9]. This can be improved by at least one order of magnitude reducing the temperature of the atoms and with a better control of the intensity of the light beam used for spectroscopy.

Indeed, all the light sources used in our experiment are solid state; the compactness and reliability of such sources represent one of the first steps towards the realization of a transportable optical standard to be employed

in future tests of fundamental physics on Earth and in space.

For the ultimate performance of a clock based on strontium, the most interesting transition would seem to be the doubly forbidden 1S_0 - 3P_0 transition in either ^{87}Sr or ^{88}Sr isotopes. While unprecedented levels of stability and accuracy have been predicted for these two transitions, such a system at this moment is a challenging task in terms of LO requirements and the time needed for the spectroscopy.

This work is supported by INFN, ASI, MIUR, CRF, and LENS.

-
- [1] A. Derevianko, S. G. Porsev, S. Kotochigova, E. Tiesinga, and P. S. Julienne, “Ultracold collision properties of metastable alkaline-earth atoms”, *Phys. Rev. Lett.* **90**, 063002 (2003)
 - [2] Y. Bidel, B. Klappauf, J. C. Bernard, D. Delande, G. Labeyrie, C. Miniatura, D. Wilkowski, and R. Kaiser, “Coherent light transport in a cold strontium cloud”, *Phys. Rev. Lett.* **88**, 203902 (2002)
 - [3] H. Katori, M. Takamoto, V. G. Pal’chikov, and V. D. Ovsiannikov, “Ultrastable optical clock with neutral atoms in an engineered light shift trap”, *Phys. Rev. Lett.* **91**, 173005 (2003)
 - [4] M. Takamoto, F.-L. Hong, R. Higashi and H. Katori, “An optical lattice clock”, *Nature* **435**, 03541 (2005)
 - [5] U. Sterr, C. Degenhardt, H. Stoehr, Ch. Lisdat, H. Schnatz, J. Helmcke, F. Riehle, G. Wilpers, Ch. Oates, L. Hollberg, “The optical calcium frequency standards of PTB and NIST”, *C. R. Physique* **5**, 845 (2004)
 - [6] T. Hong, C. Gramer, W. Nagourney, and E. N. Fortson, “Optical clocks based on ultranarrow three-photon resonances in alkaline earth atoms”, *Phys. Rev. Lett.* **94**, 050801 (2005)
 - [7] R. Santra, E. Arimondo, T. Ido, C. H. Greene, and J. Ye, “High accuracy optical clock via three-level coherence in neutral bosonic ^{88}Sr ”, *Phys. Rev. Lett.* **94**, 173002 (2005)
 - [8] H. Marion, F. Pereira Dos Santos, M. Abgrall, S. Zhang, Y. Sortais, S. Bize, I. Maksimovic, D. Calonico, J. Grünert, C. Mandache, P. Lemonde, G. Santarelli, Ph. Laurent, and A. Clairon, C. Salomon, “Search for variations of fundamental constants using atomic fountain clocks”, *Phys. Rev. Lett.* **90**, 150801 (2003)
 - [9] T. Ido, T. H. Loftus, M. M. Boyd, A. D. Ludlow, K. W. Holman, and J. Ye, “Precision spectroscopy and density-dependent frequency shifts in ultracold Sr”, *Phys. Rev. Lett.* **94**, 153001 (2005)
 - [10] B.C. Young, F.C. Cruz, W.M. Itano, J.C. Bergquist, “Visible lasers with subhertz linewidth”, *Phys. Rev. Lett.* **82**, 3799 (1999)
 - [11] G. Ferrari, P. Cancio, R. Drullinger, G. Giusfredi, N. Poli, M. Prevedelli, C. Toninelli, and G.M. Tino, “Precision frequency measurement of visible intercombination lines of strontium”, *Phys. Rev. Lett.* **91**, 243002 (2003)
 - [12] G. Ferrari, T. Brzozowski, R. Drullinger, N. Poli, M. Prevedelli, C. Toninelli, and G. M. Tino, “Laser sources for precision spectroscopy on atomic strontium”, *Proc. SPIE* **5478**, 210 (2004)
 - [13] J. K. Crane, M. J. Shaw and R. W. Presta, “Measurement of the cross section for collisional broadening of the intercombination transition in calcium and strontium”, *Phys. Rev. A* **49**, 1666 (1994)
 - [14] N. Poli, R. E. Drullinger, G. Ferrari, J. Léonard, F. Sorrentino, and G. M. Tino, “Cooling and trapping of ultracold strontium mixtures”, *Phys. Rev. A* **71**, 061403(R) (2005)
 - [15] T. Ido and H. Katori, “Recoil-free spectroscopy of neutral Sr atoms in the Lamb-Dicke regime”, *Phys. Rev. Lett.* **91**, 053001 (2003)
 - [16] G. Ferrari et al., unpublished
 - [17] those values are calculated assuming a quantum projection noise limited measurement done with 10^6 free falling atoms at 400 nK with a cycle time of 350 ms.