



UNIVERSITÀ
DEGLI STUDI
FIRENZE

FLORE

Repository istituzionale dell'Università degli Studi di Firenze

Remotely Controllable Robotic System to Detect Shallow Buried Objects with High Efficiency by Using an Holographic 4 GHz Radar

Questa è la Versione finale referata (Post print/Accepted manuscript) della seguente pubblicazione:

Original Citation:

Remotely Controllable Robotic System to Detect Shallow Buried Objects with High Efficiency by Using an Holographic 4 GHz Radar / Arezzini, I.; Calzolari, Marco; Lombardi, L.; Capineri, Lorenzo; Kansal, Y.. - ELETTRONICO. - (2012), pp. 1207-1211. (Intervento presentato al convegno PIERS 2012 tenutosi a kuala lumpur nel 27-30 March 2012).

Availability:

This version is available at: 2158/651696 since: 2020-01-08T14:13:11Z

Publisher:

PIERS

Terms of use:

Open Access

La pubblicazione è resa disponibile sotto le norme e i termini della licenza di deposito, secondo quanto stabilito dalla Policy per l'accesso aperto dell'Università degli Studi di Firenze (<https://www.sba.unifi.it/upload/policy-oa-2016-1.pdf>)

Publisher copyright claim:

(Article begins on next page)

Remotely Controllable Robotic System to Detect Shallow Buried Objects with High Efficiency by Using an Holographic 4 GHz Radar

I. Arezzini¹, M. Calzolari¹, L. Lombardi¹, L. Capineri¹, and Y. Kansal²

¹Dipartimento Elettronica e Telecomunicazioni, Università di Firenze, Firenze 50139, Italy

²Birla Institute of Technology and Science, Pilani, India

Abstract— The ambit of non-destructive testing has several diagnostic methods, each with its own characteristics. The microwave high resolution imaging methods allows the detection of shallow buried objects with high plane resolution. The diagnostic method that uses the holographic subsurface radar up to 4 GHz (RASCAN 4/4000) allows obtaining images of the dielectric contrast at a high spatial resolution (about 1 cm). The scanning of large areas of several square meters with a subsurface radar requires an automatic scanning tool that must also associate the obtained dielectric contrast data with the relative position of measurement. The necessity of an automated scanning system has led to the creation of a robotic platform, equipped with a wireless remote connection, with a high degree of expandability and flexibility, also for use with other types of sensors (acoustic, ultrasonic, ...).

The mechanical part of the robotic system consists of a motorized platform, which is entrusted with the advancement; and of a system for the scanning motion of radar head, transverse to the direction of advancement. The electronic part consists of several modules connected together by a bus 485 and connected remotely to a computer by a Bluetooth wireless connection. The developed computer software sends control instructions to the robot and plots the obtained dielectric contrast data along with the relative position of measurement to obtain a picture of the scan.

The holographic radar, Rascan type 4/4000 can be programmed to scan the surface with up to 10 discrete frequencies in order to get high phase contrast for objects buried at different depths.

The developed robotic system successfully scans large areas of land to detect shallow buried objects, while being remotely controlled through a computer.

The trajectory control was carried out on Flex board, with *dsPIC*® processor onboard and programmed with *Scicoslab*, an integrated development environment equipped with visual programming tools.

The position of robotic platform is measured with optical position sensors and used also in the trajectory control system.

1. INTRODUCTION

Non-destructive testing methods for the detection of shallow buried objects or cavities include ultrasound, infrared and ground penetrating radar techniques. The advantage of the ground penetrating radar is the fast acquisition and possibility to operate without any contact with the surface. These characteristics ascertain that the probing antenna can be mounted on a robotic vehicle that can scan large surfaces in lesser time than the standard method of manual scanning.

The sub-superficial radar through a holographic technique allows obtaining images of the microwave dielectric constant with a high spatial resolution (1 cm). The microwave holographic radar used is RASCAN 4/4000 with working frequency up to 4 GHz [1].

The produced system is a robotic platform designed to be used with the holographic radar RASCAN 4/4000 while maintaining certain flexibility for use with other types of sensors (acoustic, optical, infrared). In Fig. 1 is shown the architecture of the robot.

The robot is a differential drive rover, with the direction and movement being determined by the speed of the two front wheels.

The movement of the robot is performed by two frontal motors (model *615 30Q 1/64* from *Bernio Elettromeccanica s.n.c.*), on the rear part are two pivoting wheels.

The robot is also provided with speed and position control in which the individual velocity and position of each of the two engines is monitored via optical encoders (model *SE22-300-2-CPU-S* from *VEMtech s.c.r.l.*) mounted on each of the two motors.

The realization of the control system is based on a model of the robot in which there are three distinct elements:

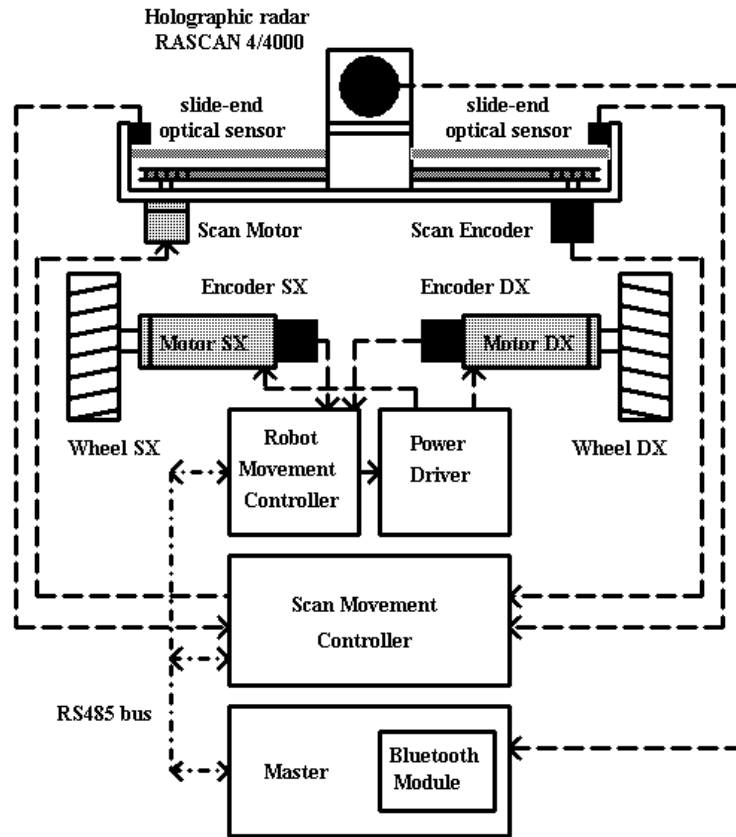

Figure 1: Block Scheme of the robotic radar object scanner.

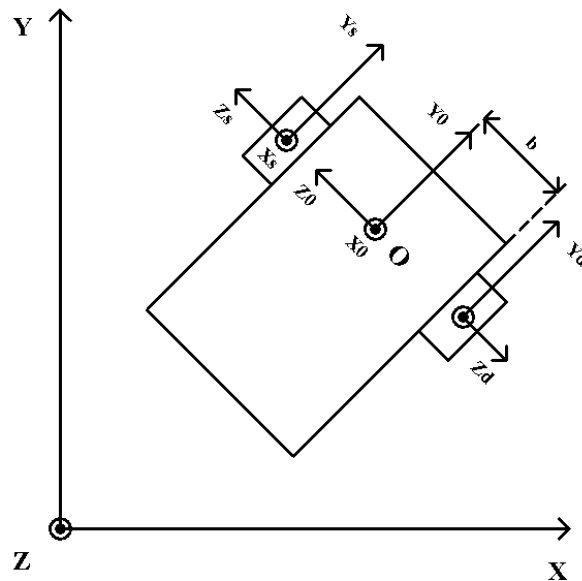

Figure 2: Configuration space robot.

- The body of robot.
- The left wheel of the robot.
- The right wheel of the robot.

Figure 2 shows the configuration space of the robot with respect to the absolute axes. The wheels and the body of the robot make an angle θ with the Cartesian abscissa, and determine the pose of the robot relative to the point O.

The movement controller of the robot consists of a high-level and two low-level controllers, one for each wheel. The high-level control system for tracking the trajectory was designed using a Lyapunov controller.

In Fig. 3 is shown the expression of low-level controller in the Laplace domain.

In Table 1 are mentioned the quantities used in the low-level controller and their explanation. It also specifies the following values and makes the following assumptions:

- $T_v \approx T_m$.
- $K_p = 7$ obtained from experimental testing.
- $K_v = 34$.

The controller described has been implemented on *Flex* board and developed in *Scicoslab* [2] integrated environment, using a visual programming language appropriately customized with new graphical blocks.

The control board is flanked by the power board that mounts two *TB6549 Toshiba* drivers.

The electronics on board of the robot is composed of a control card, the power of the control board for the lateral movement of the radar and the holographic master card, both of which are connected to the control board through RS485 Flex. The master board communicates with a remote PC via Bluetooth.

Both the RS485 bus communications, between the circuit boards mounted on the robot and the between the master card and the remote PC via Bluetooth use the same type of communication protocol, the structure and description of the frame of which are shown in Table 2.

The holographic radar has two receiving antennas, for parallel and perpendicular polarization, with each antenna is associated an output analog channel.

The frequency of the radar is selected by an external voltage that controls an internal VCO.

$$L(s) = \frac{K_v K_m}{s^2} \frac{T_v s + 1}{T_m s + 1} (s + K_p)$$

$$K_m = \frac{1}{K_e} \quad T_m = \frac{R_a J}{K_e K_t}$$

Figure 3: Expression of low-level controller.

Table 1: Quantities used in low-level controller and their explanation.

R_a	amour resistance (1.45Ω)
K_e	motors dielectric constant (1 Vs/rad)
K_t	motor torque constant (1 Nm/A)
J	moment of inertia respect to the axis of the motor (0.0193 kgm^2)



Figure 4: Measurement setup with indicate TIN and PMA-2 position.

The Master Communication Card manages communications, measures the two output analog channels from the holographic radar and also generates the necessary VCO voltage to select the desired operating frequency.

A test is performed with setup shown in Fig. 4 with metallic a TIN buried at 2 cm of depth and PMA-2 plastic simulant mine buried at 3 cm of depth.

The blue disk indicates the position of the TIN and yellow disk indicates the position of PMA-2. The disks are obviously removed during robot scanning.

In Fig. 5 are shown the viewgrams of output signals from holographic radar RASCAN 4/4000 obtained during an experiment done on the field (see Fig. 4). The samples are acquired along one scan line with length of about 1m and passing thro the center of the tin and PMA-2 targets. The scan has been repeated three times to check the repeatability of the measurements. Two metal

Table 2: Frame Structure of the communication protocol.

<i>Name of field</i>	<i>Length [byte]</i>	<i>Description</i>										
<i>Header</i>	2	<i>Header</i> identifies the beginning of the frame. The values of the 2 bytes are fixed and their values are: DLE = 16 STX = 2										
<i>Packet type</i>	1	<i>Packet type</i> is the value that identifies the packet type. The following table shows packet types and their identifiers. <table border="1" style="margin-left: auto; margin-right: auto;"> <thead> <tr> <th>PACKET TYPE</th> <th>IDENTIFIER</th> </tr> </thead> <tbody> <tr> <td>Data</td> <td>17</td> </tr> <tr> <td>Command</td> <td>18</td> </tr> <tr> <td>Flux</td> <td>19</td> </tr> <tr> <td>Signals</td> <td>20</td> </tr> </tbody> </table>	PACKET TYPE	IDENTIFIER	Data	17	Command	18	Flux	19	Signals	20
PACKET TYPE	IDENTIFIER											
Data	17											
Command	18											
Flux	19											
Signals	20											
<i>Paralen</i>	1	<i>Paralen</i> indicates the length in bytes of the packet.										
<i>Message</i>	variable	<i>Message</i> represents the information content.										
<i>CRC</i>	1	<i>CRC</i> allows error checking, is calculated by initially putting CRC = 0 and then make the XOR with the previous bytes excluding the 2-byte header.										
<i>Trailer</i>	2	<i>Trailer</i> Identifies the end of the frame. The values of the 2 bytes are fixed and their values are: DLE = 16, STX = 3										

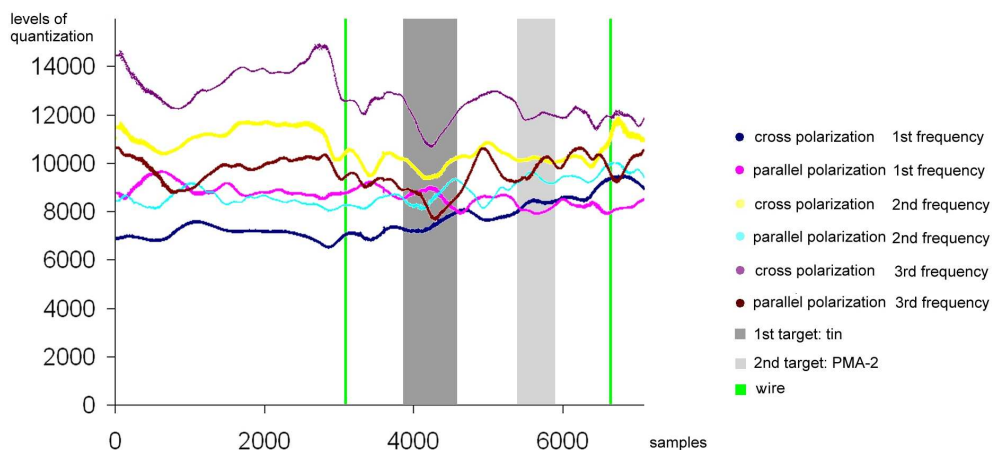

Figure 5: Signals from two output channels for 3 programmed frequencies: Grey color band indicate TIN and PMA-2 positions and green color lines two metal wires.

wires perpendicular to scanning line are placed on the ground surface to have a reference target to align multiple measurements. These two targets are shown with green lines in Fig. 5, while the tin and the small plastic PMA-2 are shown with grey bands with dimensions corresponding to their diameter. There is a good correlation between the tin position and the variation of the phase contrast signal while it is less evident the PMA-2 target. The full acquisition of the surface will be implemented and the corresponding phase contrast images will be further processed with feature extraction and classification algorithms that have been already developed for interpretation of holographic images [3].

ACKNOWLEDGMENT

The authors wish to acknowledge the contribution of Pierluigi Falorni and Francesco Fiesoli for the organization of the experimental tests.

REFERENCES

1. Ivashov, S., V. V. Razevig, I. A. Vasiliev, A. V. Zhuravlev, T. D. Bechtel, and L. Capineri, "Holographic subsurface radar of RASCAN type: Development and applications," *IEEE Journal of Selected Topics in Earth Observations and Remote Sensing*, accepted on June 5, 2011, in Print Digital Object Identifier JSTARS-2010-00097.
2. <http://erika.tuxfamily.org/scilabscicos.html>.
3. Windsor, C. G. and L. Capineri, "Distinguishing buried mines from battlefield clutter using holographic radar," *Progress In Electromagnetics Research Symposium Abstracts*, March 20–23, 2011, Marrakesh, Morocco.