



## 2. Genotype – phenotype correlations

(<http://homes.esat.kuleuven.be/~bioiuser/gpp/tools.php>) by using the three tools ToppGene, Endeavour and Suspects, allowing a prioritization of candidate genes based on functional similarity with a training gene list. Prioritization identified a candidate variant in DST gene (OMIM#614653), which encodes *dystonin*, a large protein member of the plakin protein family, which bridges the cytoskeletal filament networks. Different DST transcripts are expressed in the central nervous system, muscle, and skin, although mutations in this gene are not usually associated with cardiomyopathies. We therefore excluded the present gene from our analysis.

After data filtering and integration of filtered results with patient's clinical features, 4 potential mutations were selected. Only two of them co-segregated in the family: c.878A>T, p.Glu293Val variant in the *Desmoplakin gene* and c.626A>C, p.Tyr209Ser variant in the cytochrome c oxidase assembly gene (SCO2). Since the cardiomyopathy related to SCO2 gene mutation is usually associated with encephalopathy and is fatal in children, we excluded the causative role of such gene in our family. Therefore, we considered the DSPGlu293Val variant as disease causing and we hypothesized a modifier role for the SCO2 variant.

### *Naxos disease and Carvajal syndrome*

In 1986, an association of cardiomyopathy with wooly hair and palmoplantar keratoderma was first reported in families from the Greek island of Naxos [67]. This autosomal recessive cardiocutaneous syndrome ("Naxos disease")[68] presented clinical and histopathological characteristics of arrhythmogenic right ventricular cardiomyopathy [69]. In 1998 Carvajal [70] reported a variant of Naxos disease in families from India and Ecuador, respectively, in which the heart disorder presented

## *2. Genotype – phenotype correlations*

with a more pronounced left ventricular involvement and early morbidity. Naxos disease and Carvajal syndrome are now considered as one entity with clinical and genetic heterogeneity.

Molecular genetic investigations in families with this cardiocutaneous phenotype have identified mutations in genes encoding the cell adhesion proteins plakoglobin and desmoplakin. The structural and functional integrity of cardiac tissue is supported by desmosomes, adherens junctions and gap junctions located at intercalated disks [71]. In desmosomes, plakoglobin, plakophilin2 and desmoplakin anchor desmin intermediate filaments to desmosomal cadherins, securing the mechanical cell–cell adhesion. Desmosomal cadherins (desmoglein and desmocollin) are transmembrane proteins forming an extracellular zipper - like dimer with the corresponding part of desmosomal cadherins of the adjacent myocardial cell. Plakoglobin and plakophilin2 are armadillo proteins located at the outer dense plaque of desmosomes which bind with the N - terminal of desmoplakin and with the C - terminal of desmosomal cadherins. Desmoplakin is a larger dumbbell - shaped molecule which makes up the inner dense plaque with its middle coiled - coiled rod domain and binds via its C - terminal with desmin intermediate filaments. Plakoglobin is the only desmosomal protein which is also found at adherens junctions where it is involved in linking with the actin cytoskeleton of adjacent myocardial cells.

Normal functioning and integrity of desmosomes is of utmost importance in myocardium and skin particularly of palms and soles, tissues that experience constant mechanical stress. Intercellular junctions not only maintain tissue integrity but also integrate mechanical and signaling pathways in the regulation of cell growth, differentiation and development.

***A family with early onset of LV aneurysm and ventricular arrhythmias***

The proband was a 28 year-old man who experienced repeated episodes of sustained ventricular tachycardia, treated in the ER with DC shock. The ECG showed pathological Q waves in the infero-lateral leads [Figure 2.3-5], while the echocardiogram revealed a small aneurysm of the basal segment of the infero-lateral wall. The coronary angiogram performed showed normal coronary artery. The cardiac magnetic resonance, performed after a few months, confirmed the presence of the LV aneurysm [Figure 2.3-6]. The patient had no relevant clinical history and a normal cardiovascular risk profile. Therefore a diagnosis of myocarditis was made.

A couple of months later, his father underwent cardiological evaluation as a part of pre-operative assessment. His ECG was indistinguishable from that of his son and the echocardiogram showed an infero-lateral aneurism. He was asymptomatic, with no history of angina, dyspnea or palpitations. Therefore, we supposed a familial form of cardiomyopathy. The brother of the proband was also examined and he presented the same clinical phenotype.

**Figure 2.3-5: ECG of the proband (next page)**

ECG showing pathological Q waves in the inferior (II-III- avF) and lateral leads (V5-V6).

**Figure 2.3-6: Pedigree and clinical phenotype**

**Top left panel:** family pedigree showing a dominant inheritance

**Top right and bottom panels:** cardiac magnetic resonance images showing a small aneurysm of the basal segment of the infero-lateral wall, with transmural fibrosis (LGE).

## 2. Genotype – phenotype correlations

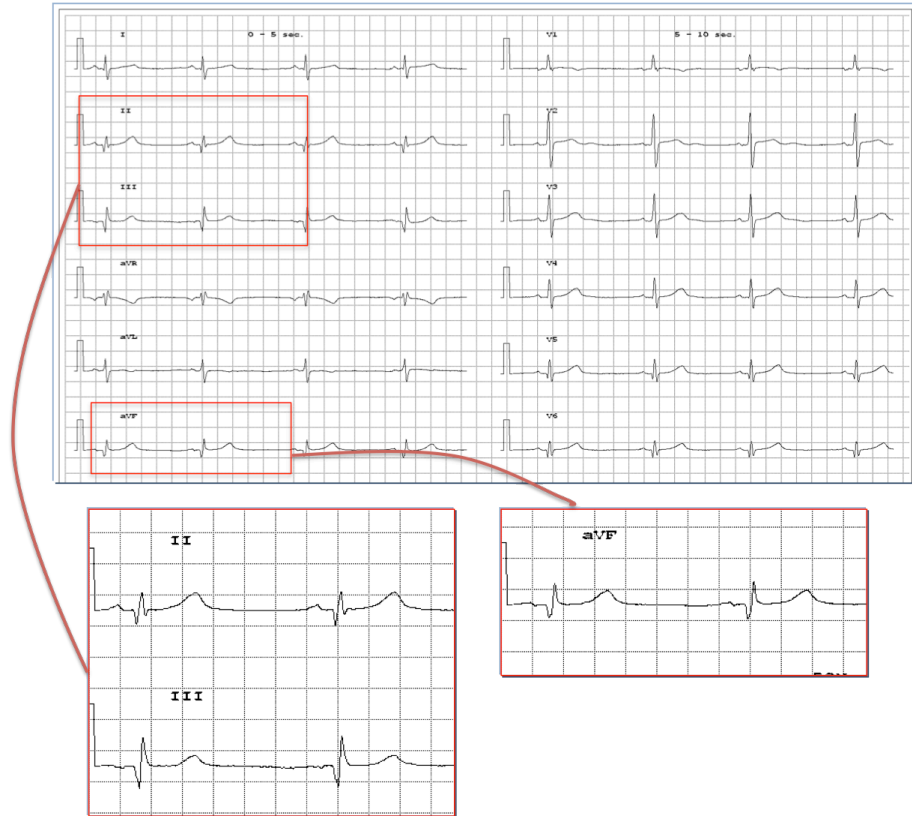

Figure 2.3-5: ECG of the proband

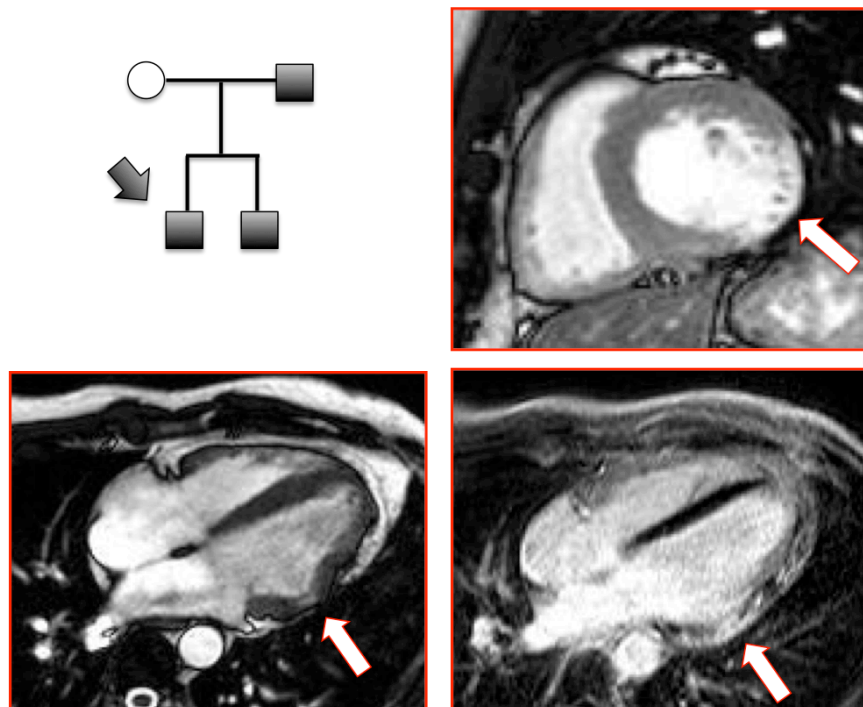

Figure 2.3-6: Pedigree and clinical phenotype

## 2. Genotype – phenotype correlations

While the familial nature of the cardiac disease was clear, the clinical phenotype was atypical and undetermined. Therefore, since standard genetic analysis could not be performed, we employed NGS to perform a whole exome sequencing study.

Data analysis identified 64115 variants, 19209 of which located in coding regions and intron-exon junctions. After frequency filtering (variants with minor allele frequency < 5% in 1000 Genomes Project), 1343 variants were selected. Among these, 955 variants were not present in dbSNP Release. Prioritization identified a candidate variant in DSG2 gene (OMIM#610193), *desmoglein 2*, c.1912G>A p.Gly638Arg, that co-segregated in the family. *Desmoglein* is an essential component of desmosomes and it is known to be associated with arrhythmogenic cardiomyopathy, as described in the previous paragraph.

Genetic analysis allowed the definition (re-definition) of the clinical phenotype as an atypical, non-syndromic form of ARVC with localized involvement of the LV. This atypical presentation, initially suspected to be novel phenotypes, has been reassigned as atypical presentations of a well-known genetic disorder, expanding its phenotypic spectrum.

### 2.3.3 Targeted approach

#### ***Family with HCM, noncompaction and supraventricular arrhythmias***

We assessed 19 subjects from a large four-generation Italian family living in central and northern Italy, who remained undiagnosed following conventional Sanger sequencing testing. Affected individuals of this family had evidence of cardiomyopathic involvement, transmitted with an

## 2. Genotype – phenotype correlations

autosomal dominant inheritance pattern, comprising variable combinations of 3 distinctive features: asymmetric LV hypertrophy (LVH) consistent with HCM, early onset of supraventricular arrhythmias and atrioventricular (AV) block, and regional LV noncompaction [Figure 2.3-7: family pedigree and figure legend].

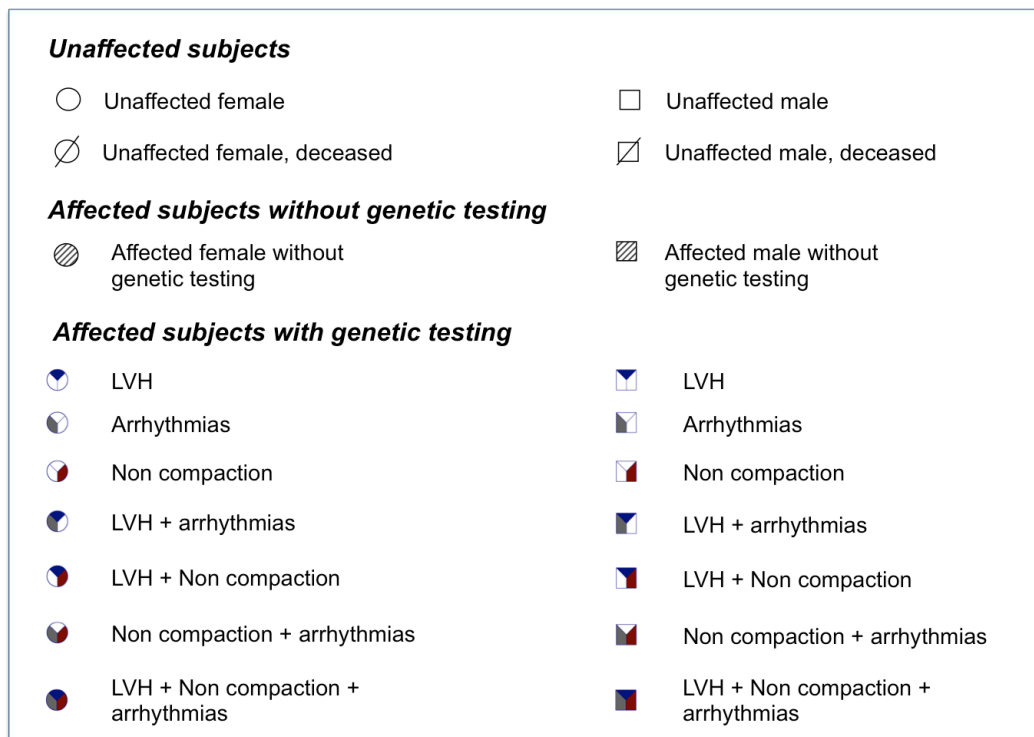

**Figure 2.3-7: pedigree (next page) and figure legend.**

Pedigree including the results of ACTN2 Met 228Thr cosegregation in 18 family members. Arrow: proband. +/- presence of the heterozygous Met228Thr; -/- absence of the heterozygous Met228Thr .

## 2. Genotype – phenotype correlations

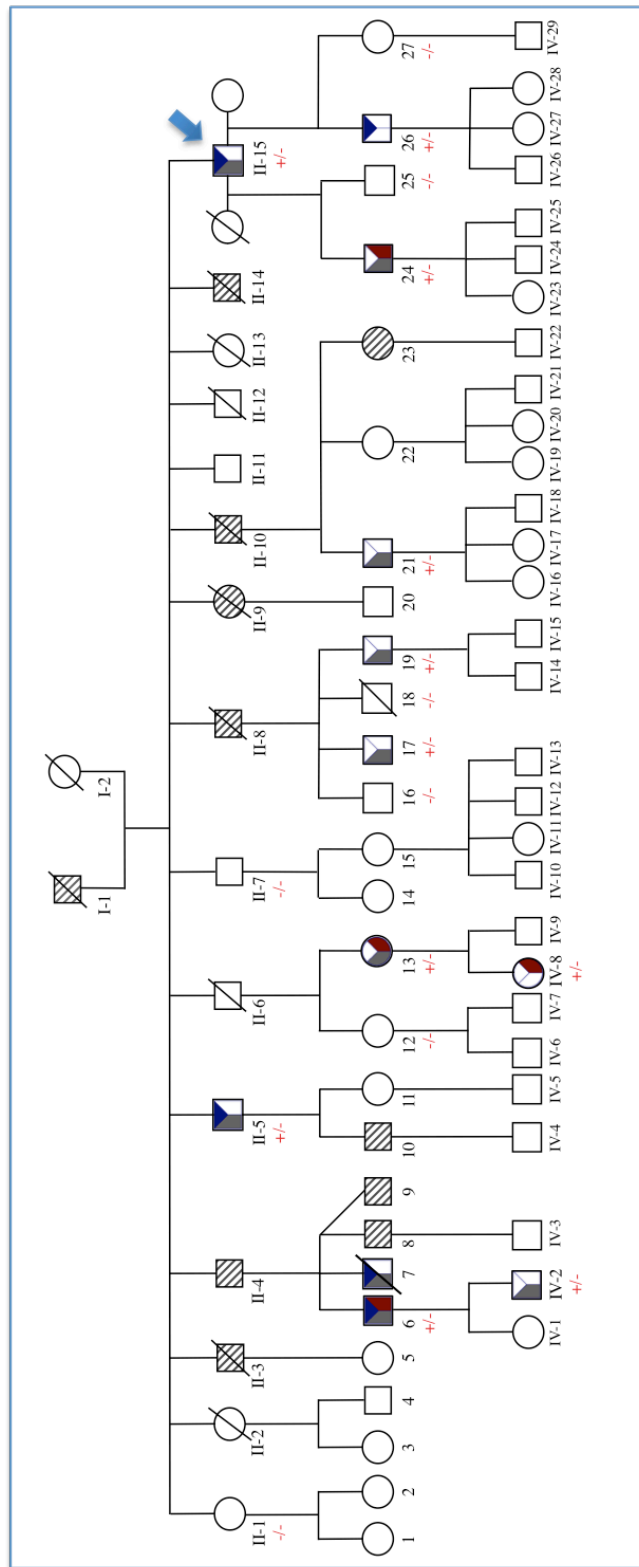



## *2. Genotype – phenotype correlations*

The proband (II-15) was an 82 year-old man with mild, asymmetric LV hypertrophy localized to the basal and mid-septum, marked bi-atrial dilatation and a restrictive LV filling pattern with preserved systolic function. He had been diagnosed with nonobstructive HCM almost three decades earlier, and followed at our Institution since 2005. Remarkably, he had a history of paroxysmal atrial fibrillation (AF) which presented at the age of 30, which subsequently evolved into permanent AF with advanced AV block, requiring VVI pacing at the age of 68 [Figure 2.3-8]. In 2008 he proved to be negative for mutations in the coding regions and splice sites of the 8 most prevalent sarcomere genes. Despite his early onset of disease manifestations and adverse cardiac remodelling, consistent with restrictive evolution of HCM, he remained fully active with only mild functional limitation (functional class NYHA class II). Furthermore, he remained free from cardioembolic complications although he repeatedly refused treatment with oral anticoagulants. He currently remains on diltiazem, loop diuretics, kanrenone and low-dose aspirin. His pacemaker had been replaced 4 times, and has never been upgraded to an implantable defibrillator; no significant ventricular arrhythmias have been noted on repeated 24-hour ECG Holter monitoring. His Pro-BNP in 2009 was 1013 pg/ml.

## 2. Genotype – phenotype correlations

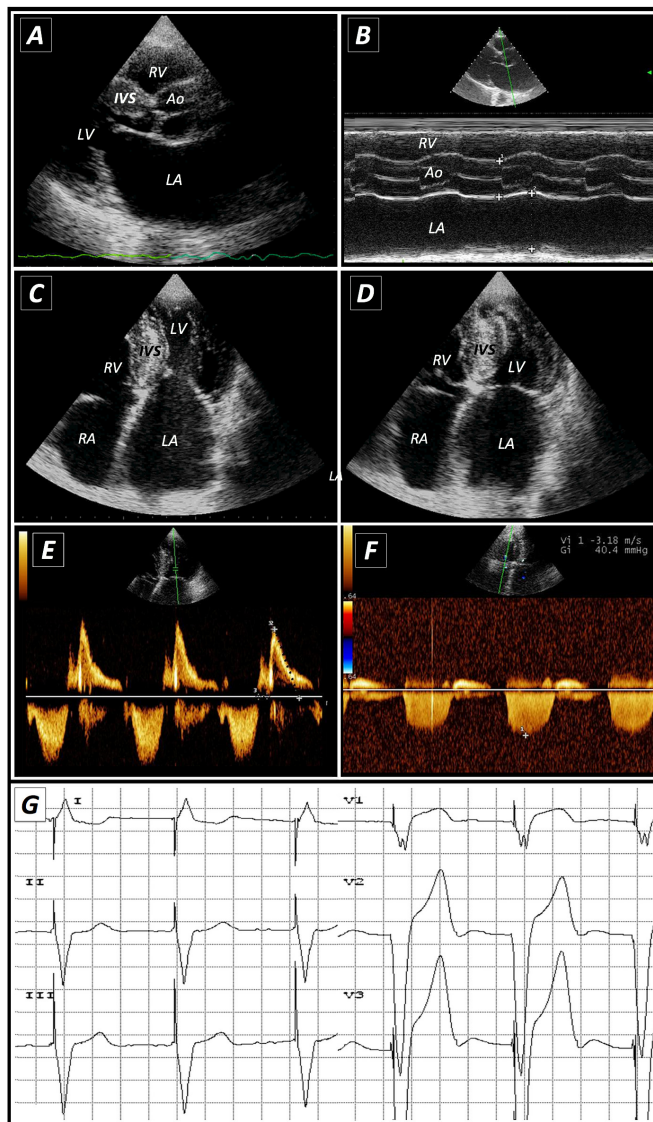

**Figure 2.3-8: Clinical features of the proband (II-15)**

A-B: Parasternal long axis (2d and M-mode) of the proband, showing marked left atrial dilatation (52 mm), with mild hypertrophy of the septum (16 mm) and small LV cavity (telediastolic diameter 40 mm).

C-D: Apical 4 chamber view (diastole and systole). Asymmetric LV hypertrophy, with maximal LV wall thickness of the basal and mid-septum, small LV cavity (telediastolic volume 63 ml) and marked bi-atrial dilatation (LA volume 220 ml). Ejection fraction was normal (70%).

E: Restrictive mitral inflow filling pattern, with deceleration time of 144 ms (rhythm: AF with ventricular pacing).

## 2. Genotype – phenotype correlations

F: Tricuspid regurgitation jet velocity showing pulmonary hypertension, with an RV/RA gradient of 44 mmHg. Inferior vena cava diameter (not showed) was 3.1 cm, with respiratory variation of diameter <50%.

G: ECG (DI, DII and DIII, V1-3 leads) showed AF with complete AV block and VVI pacing.

Three additional family members had similar echocardiographic and clinical features, characterized by nonobstructive HCM with restrictive evolution, AV block and biatrial dilatation: the proband's brother (II-5), aged 80, who developed permanent AF at the age of 64 years and required VVI pacing for advanced AV block at 68 years; and two of his nephews (III-6 and III-7). Patient III-6 was a 50-year old man with a long-standing history of frequent ventricular ectopic beats and sustained supraventricular arrhythmias associated with apical HCM and regional LV noncompaction; he recently developed paroxysmal AF and advanced AV block requiring permanent pacing. His brother (III-7) required surgery at the age of 15 due to a large atrial septal defect (ostium secundum) associated with severe right-sided heart failure. At that age, he already showed first degree AV block and frequent supraventricular ectopic beats; his echocardiogram showed apical HCM with marked bi-atrial dilatation [Figure 2.3-9]. He unfortunately died of heart failure-related complications a few years later.

**Figure 2.3-9: Marked clinical heterogeneity in family members (next page).**

**Panel A-F: morphological features of some family members.**

A: Patient III-17 showed mild left atrial dilatation (index volume 44 ml/m<sup>2</sup>).

B: The 15 year-old proband's nephew (III-7) had apical HCM with marked bi-atrial dilatation; he required surgery at the age of 15 due to a large atrial septal defect (ostium secundum). At that age, he already showed 1st degree AV block and frequent supraventricular ectopic beats. He died a few years later due to right-sided heart failure complications.

C: Patient III-6 was a 50-year old man had HCM with restrictive evolution, marked biatrial dilatation and regional LV noncompaction. He had a long-standing history of frequent ventricular ectopic beats and sustained supraventricular arrhythmias, including paroxysmal AF. He also required permanent pacing due to advanced AV block (see also panel B6).

D: The proband's brother (II-5), aged 80, had nonobstructive HCM with restrictive evolution, and biatrial dilatation: he developed permanent AF at the age of 64 years and required VVI pacing for advanced AV block at 68 (see also panel B5).

E-F: Echocardiogram and cardiac MRI of two female patients (patient III-13 and IV-8 respectively), showing LV non compaction of the apex, distal septum and lateral wall.

**Panel G-N: broad spectrum of electrocardiographic abnormalities and supraventricular arrhythmias.**

G: Isolated and short run of supraventricular ectopic beats on Holter ECG monitoring (individual III-13).

H: Second Degree sinoatrial block, Type II, of individual III-6, at the age of 9. (Arrow indicates the dropped P wave).

I: Supraventricular tachycardia (individual III-17). Arrows indicate P waves.

L: First degree atrio-ventricular block (individual III-19).

M: Atrial fibrillation with a slow ventricular response (individual III-24).

N: Junctional rhythm (P waves are absent), of individual III-6, who required permanent pacing at the age of 50.

## 2. Genotype – phenotype correlations

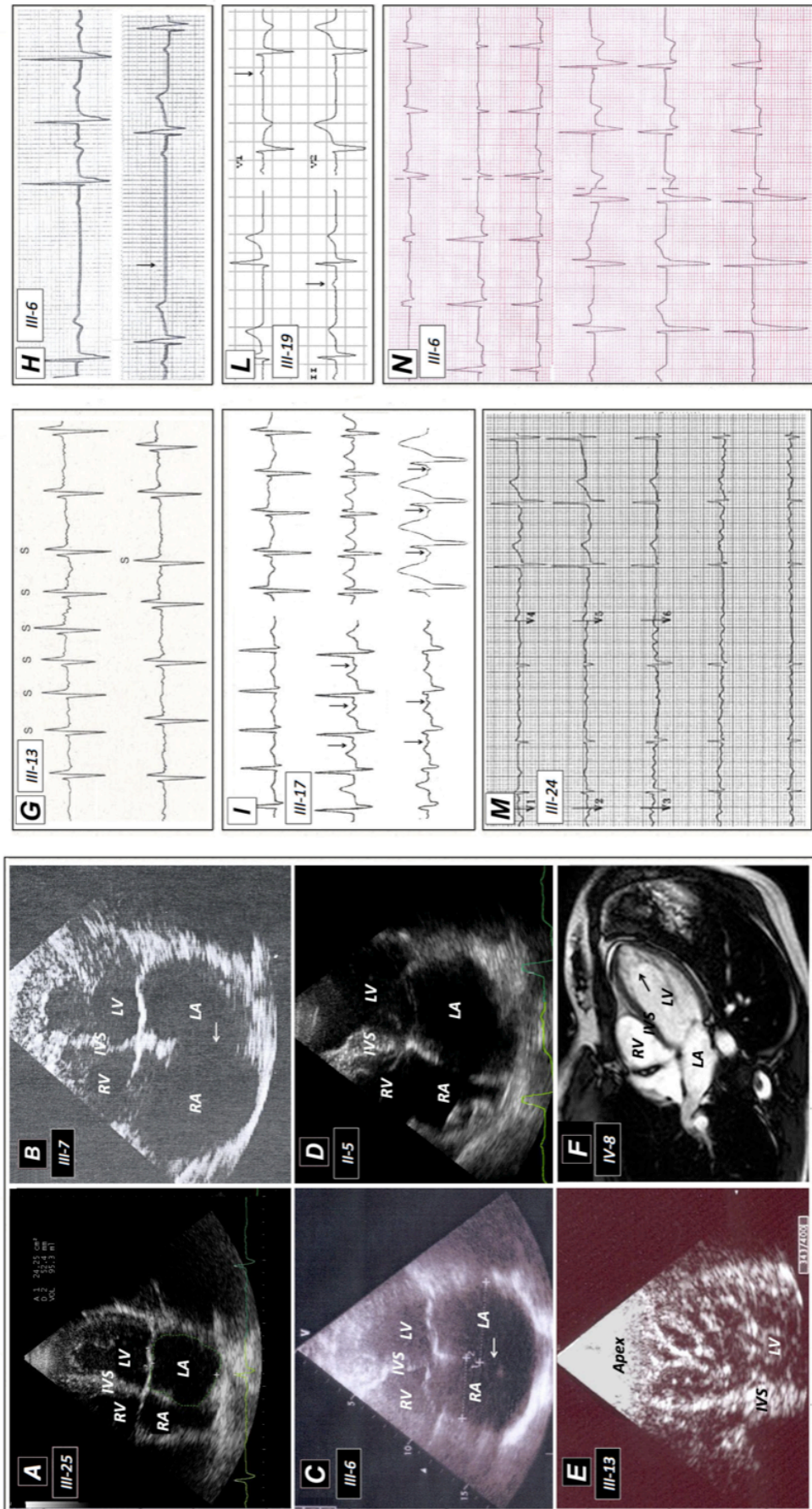

## 2. Genotype – phenotype correlations

The 4-year old son of patient III-6 (IV-2) presented at birth with esophageal atresia and tracheal fistula associated with ostium secundum atrial septal defect, requiring multiple surgery. He had multiple runs of supraventricular tachycardia, but no evidence of LVH or noncompaction. In addition cardiomyocytes show hypertrophy by intraoperative surgical biopsy of the ventricular septum [Figure 2.3-10].

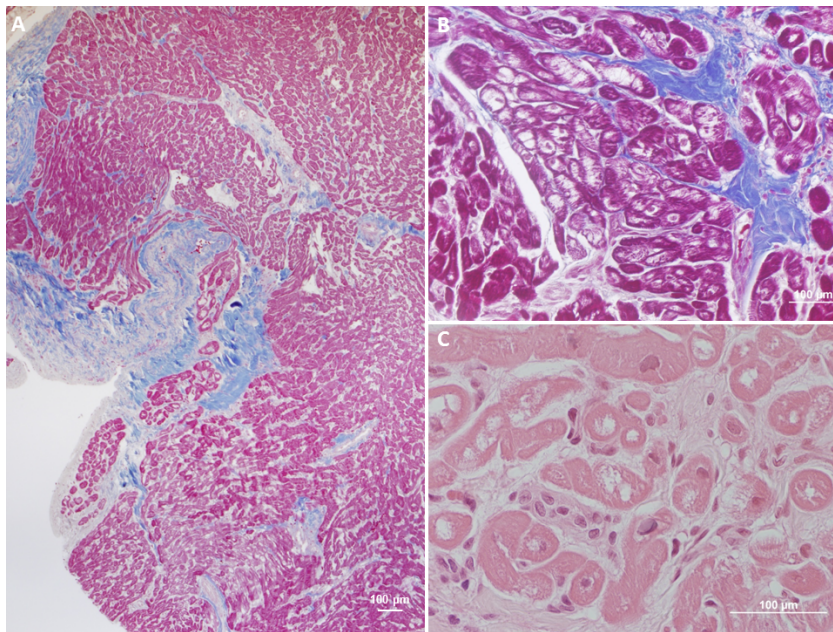

**Figure 2.3-10: Intraoperative surgical biopsy of the ventricular septum**

A) panoramic view of the surgical biopsy sample with endocardial fibrous thickening and mild disarray (trichrome stain).

B,C) cardiomyocytes show hypertrophy (mean diameter 20 micron), diffuse cytoplasmic vacuolization with perinuclear halo and dysmetric and dysmorphic nuclei, associated with focal fibrosis" (haematoxylin eosin stain, scale bar =100 micron).

The remaining patients all showed milder forms of cardiac disease, including mild apical LVH (patient III-26); regional LV non-compaction (patient III-13 and IV-8, associated with first degree AV block in the former); left atrial dilatation and supraventricular arrhythmias (patients

## 2. Genotype – phenotype correlations

III-17, III-21 and III-24, associated with first degree AV block in the latter); and left atrial dilatation with 1st degree AV block (patient III-19). None of the other family members assessed had evidence of heart disease suggesting genetic transmission of the cardiomyopathic trait. Individual III-18 died suddenly at the age of 49: autopsy showed evidence of ischemic heart disease associated with coronary atherosclerosis, with no evidence of LVH, disarray or interstitial fibrosis.

### Genetic analysis

Following genetic counseling and informed consent, proband's DNA was screened by targeted massively parallel sequencing of 36 cardiomyopathy-associated genes [Table 2.3-2].

Data analysis identified 1467 variants, 50 of which are located in coding regions and intron-exon junctions. In order to identify clinically relevant variants, data obtained from the analysis were filtered based on frequency using dbSNP Release 137, Exome Sequencing Project (ESP), 1000 Genomes Project (1KGP) and HGMDTM Professional. Then they were filtered according to the function (coding, 5' or 3' junctions), the evolutionary conservation of the affected nucleotide (PhyloP score) and pathogenic potential by in silico predictive algorithms (MutationTaster), SIFT, PolyPhen2. Following bioinformatics analysis, four likely pathogenic variants were identified: TTN NM\_003319.4:c.21977G>A (p.Arg7326Gln); TTN NM\_003319.4:c.8749A>C (p.Thr2917Pro); ACTN2 NM\_001103.2:c.683T>C (p.Met228Thr) and OBSCN NM\_052843.2:c.13475T>G (p.Leu4492Arg). The novel variant ACTN2 p.Met228Thr, located in the Actin-binding domain, proved to be the only mutation fully co-segregating with the cardiomyopathic trait in 18 additional family members (of whom 11 clinically affected).

## 2. Genotype – phenotype correlations

ACTN2\_Met228Thr was absent in 570 alleles of healthy controls and in 1000 Genomes Project, and was labelled as “Causative” by in silico analysis using PolyPhen-2, as “Deleterious” by SIFT and as “Disease-Causing” by MutationTaster.

**Table 2.3-2: List f 36 Hypertrophic Cardiomyopathy-associated genes**

Gene Symbol	NM	Gene name
ACTA1	NM_001100.3	Actin, alpha 1 , skeletal muscle
ACTC1	NM_005159.4	Actin alpha, cardiac muscle1
ACTN2	NM_001103.2	Actin,alpha 2
CALM3	NM_005184.2	Calmodulin 3 (phosphorylase kinase, delta)
CALR3	NM_145046.3	Calreticulin 3
CASQ2	NM_001232.3	Calsequestrin 2 (cardiac muscle)
CAV3	NM_033337.2	Caveolin 3
COX15	NM_078470.4	Cytochrome c oxidase subunit 15
ANKRD1	NM_014391.2	Ankyrin repeat domain 1 (cardiac muscle)
CSRP3	NM_003476.2	Cysteine and glycine-rich protein 3
DES	NM_001927.3	Desmin
FXN	NM_000144.4	Frataxin
GLA	NM_000169.2	Galactosidase-alpha
JPH2	NM_020433.4	Junctophilin 2
LAMP2	NM_002294.2	Lysosomal-associated membrane protein 2
MYBPC3	NM_000256.3	Myosin binding protein C, cardiac
MYH6	NM_002471.3	Myosin heavy chain 6, cardiac muscle,alpha
MYH3	NM_002470.2	Myosin heavy chain 6, skeletal muscle
MYH7	NM_000257.2	Myosin heavy chain 7, cardiac muscle,beta
MYL2	NM_000432.3	Myosin light chain 2, regulatory, cardiac
MYL3	NM_000258.2	Myosin light chain 3
MYLK2	NM_033118.3	Myosin light chain kinase 2, skeletal muscle
MYO6	NM_004999.3	Myosin VI
MYOZ2	NM_021245.2	Myozenin 2
NDUFV2	NM_021074.4	NADH dehydrogenase (ubiquinone) Flavoprotein 2
OBSCN	NM_0010986 23.1	Obscurin, cytoskeletal calmodulin and titin- interacting RhoGEF
PLN	NM_002667.3	Phospholamban
PRKAG2	NM_016203.3	Protein kinase, AMP-activated, gamma 2
RAF1	NM_002880.3	V-raf-1 murine leukemia viral oncogene homolog
SRI	NM_003130.2	Sorcin
TCAP	NM_003673.3	Titin-cap or Telethonin
TNNI3	NM_000363.4	Troponin I type3 (cardiac)
TNNT2	NM_000364.2	Troponin T type2 (cardiac)
TPM1	NM_000366.5	Tropomyosin 1 (alpha)
TTN	NM_0012568 50	Titin



### **ACTN2 and Z-disc protein genes as a cause of HCM**

Over the last decade, many genes that do not strictly belong to the sarcomere have been associated with rare forms of HCM [72]. These include genes coding for proteins involved in intracellular calcium handling or constituting the Z-disc - the interface between the cardiomyocyte contractile apparatus and the cytoskeleton [73].

These results support the role of Z-disc protein as a rare cause of LVH, and suggest a potential involvement of ACTN2 mutations in the genesis of supraventricular arrhythmias. Notably, our family displayed several atypical features compared to classic HCM. First, HCM patients presented with mild to moderate mid-apical LVH, with slow but distinctive progression towards a restrictive pathophysiology; none of our patients had LVH preferentially localized to the basal septum or anterior wall, and none had dynamic LV outflow obstruction. These features are consistent with ACTN2-related HCM recently described in an Australian family [74]. Furthermore, our family displayed a spectrum of clinical manifestations beyond LVH itself, including supraventricular arrhythmias and regional LV non-compaction, which were associated with HCM in the most affected family members including the proband, but were present in isolation (i.e. in the absence of LVH) in subjects with milder disease. In addition, ostium secundum atrial septal defect was present in two brothers and one of their sons: the latter finding, however, was confined to a single branch of the family, suggesting fortuitous association with a distinct genetic defect superimposed to the ACTN2 mutation. Conversely, we found little propensity to malignant ventricular arrhythmias in our patients, in that none of the affected individuals died suddenly or had sustained VT or cardiac arrest, even when marked progression of disease was noted. The most striking example is represented by the proband,

## *2. Genotype – phenotype correlations*

who remains active and with only mild functional limitation at 90 years of age. The only patient who died prematurely had undergone repair of an extensive atrial septal defect during adolescence, and his demise largely resulted from right heart failure secondary to the congenital defect on a cardiomyopathic substrate. The relatively favourable long-term clinical course in our family is in contrast with that of the ACTN2 pedigree described by Chiu et al, characterized by elevated prevalence of progressive heart failure and sudden cardiac death. Such discrepancy is evident despite the fact that both ACTN2 mutations occur within the actin-binding domain, in two adjacent calponin homology domains, suggesting that different mutations in this gene may dictate radically diverse clinical evolution and arrhythmic profile. This is in line with the heterogeneity of phenotypes associated with ACTN2, which include HCM with sigmoidal type hypertrophy and even dilated cardiomyopathy [74]. In a larger perspective, such diversity highlights the broad pathophysiological implications of mutations affecting the molecular apparatus connecting the cardiomyocyte contractile apparatus to the cytoskeleton and muscle membrane, involving other HCM –associated genes such as titin, telethonin, muscle LIM, and myozenin.

### **2.3.4. Translation of NGS into a diagnostic tool for patients with genetic cardiovascular disease: the targeted approach**

Unlike traditional approaches, where genes are generally studied one at a time, high throughput approaches can provide a global view of all the genes in a genome in a relatively fast and cost - effective manner. Among various high throughput methods, a targeted NGS approach

## 2. Genotype – phenotype correlations

describes a strategy where a specific set of genes related to the patient's phenotype are analyzed within the context of a genetic “test”.

By including virtually all known cardiomyopathy-associated genes, these panels can serve as a first line, one-fits-all approach in the clinic for any given patient, irrespective of his/her phenotype. This approach has brought several advantages: a) most diagnoses may find molecular confirmation at any center implementing NGS, avoiding the need for traveling and repeated blood sampling; b) global costs are reduced; c) even rare forms and phenocopies, such as Anderson-Fabry disease for HCM, generally requiring several years for correct identification, may be diagnosed at first attempt (and even when not clinically suspected); d) very large genes, such as titin causing DCM, technically off-limits by Sanger techniques, may be explored.

A very important implication of these enhanced possibilities is that unclassified, atypical phenotypes, for which a candidate gene approach could not be proposed, are being serendipitously diagnosed by using the powerful targeted NGS approach. For example, systematic screening exploring desmosomal genes have led to the recognition of forms of ARVC with prevalent or even isolated LV involvement (thus the proposal to rename ARVC simply as “arrhythmogenic cardiomyopathy”). Thus, NGS is helping clinicians redefine the phenotypic spectrum of single cardiomyopathies by expanding the gold standard of genetic diagnosis beyond the limits suggested by clinical investigation.

The implementation of other NGS-based approaches such as whole-exome sequencing (WES) and whole-genome sequencing (WGS) is well underway. At the present time, these approaches remain expensive, time-consuming and fraught with interpretational difficulties, largely

## *2. Genotype – phenotype correlations*

limiting their use to research purpose aimed at identifying novel disease-causing genes. Ultimately, WES or WGS will become part of a standard assessment for most patients. The pace of this transition will depend on the presence of the requisite infrastructure, regulatory standards, training and best practice guidelines for reporting.

### **2.3.5. Challenges and opportunities: the evolving role of the medical geneticist.**

The many assets of NGS come at the cost of increasing complexity. The multidisciplinary team required to interpret the biostatistical, genetic and clinical implication of NGS findings, even when a focused targeted approach is employed, are extremely demanding. Two are the main challenges: the first is to confidently discriminate disease-causing variants from rare, benign mutations with no clinical relevance. The wealth of information derived from NGS is not yet paralleled by the clinical knowledge needed to gauge the value of each identified mutation. For novel mutations (i.e. the majority), this mandates clinical studies of familial co-segregation involving dedicated physicians. Unfortunately, large, informative families are not always available. The second challenge (pertaining more to the whole-exome and –genome studies) is represented by the ethical implications of unexpected findings that may not be directly relevant to the original question (for example a mutation in a cancer-causing gene during investigations for familial cardiomyopathies). Clinical implications, often uncertain, need to be balanced against the certainty of onerous psychological consequences and a substantial risk of overdiagnosis diseases that may never occur.

## *2. Genotype – phenotype correlations*

The NGS era of gene discovery and, ultimately, molecular diagnoses heralds a fundamental change for medical genetics and medical geneticists. In addition to continuing to define phenotypes, the medical geneticist of the NGS era will have an unprecedented opportunity to identify human disease-causing genes, enable the translation of NGS into diagnostic tools and understand the role of disease modifiers to advance the care of patients with rare diseases. These geneticists will also become vital members of collaborative teams along with providers from other specialties as they use genomic results to guide patient care. As such, medical geneticists will need to complement their clinical skills with expertise in the clinical interpretation of NGS data.

In the future, medical geneticists will instead phenotype patients to facilitate the interpretation of the large data set generated by WES or WGS. Perhaps most importantly, as increasing molecular insight inevitably suggests novel therapeutic avenues, some medical geneticists will also become interventionists, configuring, trialing and instituting treatments for genetic disorders.

In conclusion, NGS represents the (ultimate) revolution for mutational screening, and is bound to change our practice in the near future. However, the wealth of information derived from NGS is not yet paralleled by the clinical knowledge needed to gauge the value of each identified mutation. As for each prior revolution in genetic diagnosis, the only reliable key to understanding is represented by our patients and their pedigrees. The psychological and ethical challenges associated with the massive potential of NGS, as well as the issue of over-diagnosis, require specific investigation in patients with inherited heart disease.

## 2. *Genotype – phenotype correlations*

### ***3. Environmental Modifiers***

---

### 3. Environmental Modifiers

*“In nature we never see anything isolated,  
but everything in connection with something else  
which is before it, beside it, under it and over it.”*

*Johann Wolfgang von Goethe*



### **3.1 The role of environmental modifiers on the phenotypic expression and outcome of hypertrophic cardiomyopathy: the “weight” of obesity**

Say you are studying three individuals who carry the same disease-causing mutation; two of these individuals suffer from the disease but exhibit different symptoms, while the third person is completely unaffected. For many inherited diseases, the same mutation is not always expressed in all individuals who carry it; moreover, when the mutation is expressed, it is not always expressed in the same way, even among different individuals of the same family. How would you explain this phenomenon? How is it possible that one family member carrying a sarcomere mutation has HCM, while another carrying the same mutation does not? What accounts for such a difference in disease expression? Answering these questions is not an easy task. Nonetheless, research has shown that variable phenotypes can be caused by a number of factors, including complex interactions between genetic and environmental factors.

This is the case of our research, conducted in a cohort of patients with hypertrophic cardiomyopathy (HCM). HCM is the most common genetic heart disease, characterized by heterogeneous phenotypic expression with extreme diversity in the pattern and extent of left ventricular hypertrophy (LVH) [1-5]. The reasons of such diversity are related to molecular pathways and triggers that remain largely unexplained. In the vast majority of genotype-positive patients, HCM is associated with mutations in genes encoding proteins of the cardiac sarcomere, most commonly beta-myosin heavy chain and myosin-binding protein C. While these molecular defects are considered responsible for

the development of LVH, there is currently no conclusive evidence to explain the variability in phenotypic expression of HCM, ranging from massive degrees to absence of LVH even within the same family [6]. Among several hypotheses, the interplay of modifier genes and environmental factors has been commonly offered as a potential explanation for phenotypic diversity [7,8]. However, the extreme heterogeneity of phenotypic expression among HCM patients, even in family members sharing the same mutation, implies that other determinants of cardiac morphology must be operative. The increased cardiac mass in patients with obstructive HCM is a striking example proving that extrinsic factors can play a primary role in the modulation of the phenotype [9, 10]. In order to address this issue, we hypothesized that obesity, an established cardiovascular risk factor known to promote LVH in the general population [11-14], could be associated with an increased left ventricular mass and cavity remodeling in this genetically determined condition.

#### **3.1 Obesity as a modulator of HCM phenotype**

Obesity is a leading preventable cause of death worldwide, and it is considered one of the most serious public health problems of the 21st century. It is classified as a disease, though it was widely perceived as a symbol of wealth and fertility at other times in history [15, 16]. As of 2008 the WHO estimates that at least 500 million adults (greater than 10%) are obese [Figure 3-1]. Obesity is known to promote LVH in the general population due to numerous pathophysiological mechanisms, such as increased sympathetic tone and leptin levels, myocardial fatty infiltration, insulin resistance, and enhanced renin-angiotensin activity. Obesity may

also cause heart failure, and has been shown to result in worsening diastolic function independent of other comorbid conditions [17].

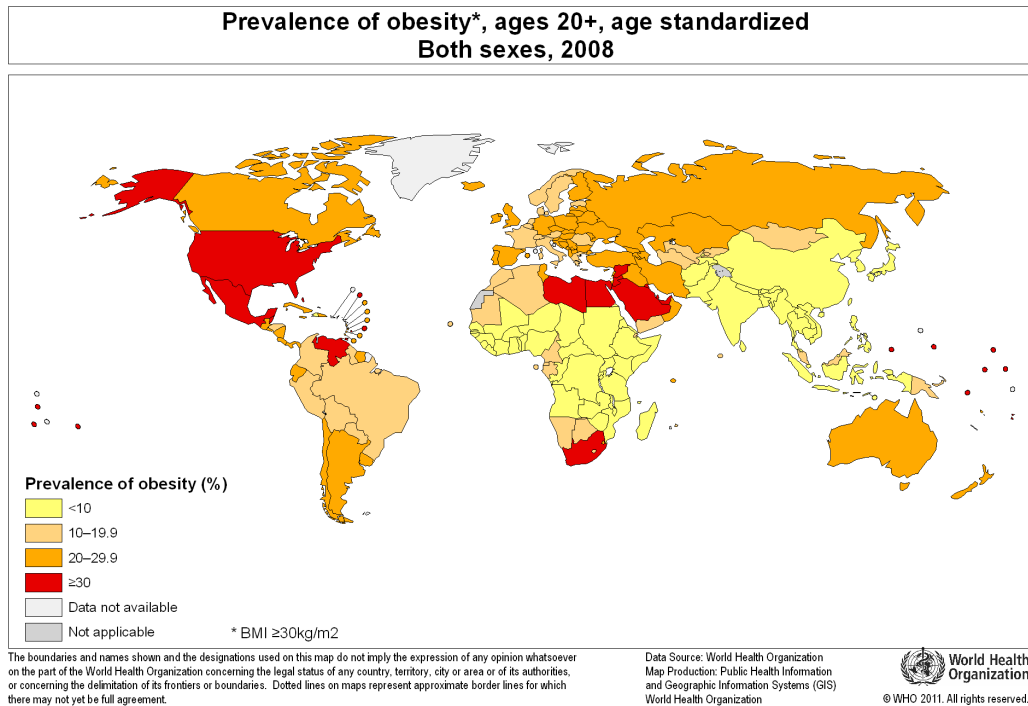

**Figure 3-1: A world map showing the prevalence and distribution of obesity**

The hypothesis that obesity could influence the magnitude of LV mass and prognosis in patients with HCM, although intuitive, had never been studied, and in 2009 it was considered a mere speculation. We therefore decided to design an observational multicenter study in order to prove this hypothesis.

Three major referral HCM centers were involved: Minneapolis Heart Institute Foundation (Minneapolis, Minnesota), Tufts Medical Center (Boston, Massachusetts) and Careggi University Hospital (Florence, Italy). The study cohort comprised 275 adult patients with HCM

consecutively referred at the 3 participating referral centers. All patients enrolled underwent a thorough clinical and instrumental evaluation, including ECG, echocardiography, cardiac magnetic resonance. The population was divided into three groups, based on body mass index (BMI): normal weight (BMI <25Kg/m<sup>2</sup>), pre-obese (BMI 25-30 Kg/m<sup>2</sup>) and obese (BMI >30Kg/m<sup>2</sup>). Only 25% of patients were classified as normal, while the majority of individuals were pre-obese or obese (respectively 38 and 37%).

The analysis of cardiac morphology and function showed that LV mass index progressively increased in pre-obese and obese patients, reflecting a direct relationship between BMI and LV mass measured by CMR [Figure 3-2]. Not only the heart of obese and pre-obese patients was more hypertrophied, but was also characterized by greater LV cavity size and volume, indicating profound remodeling of cardiac morphology [Figure 3-3]. Conversely, maximum LV wall thickness and systolic function were identical in the three subgroups.

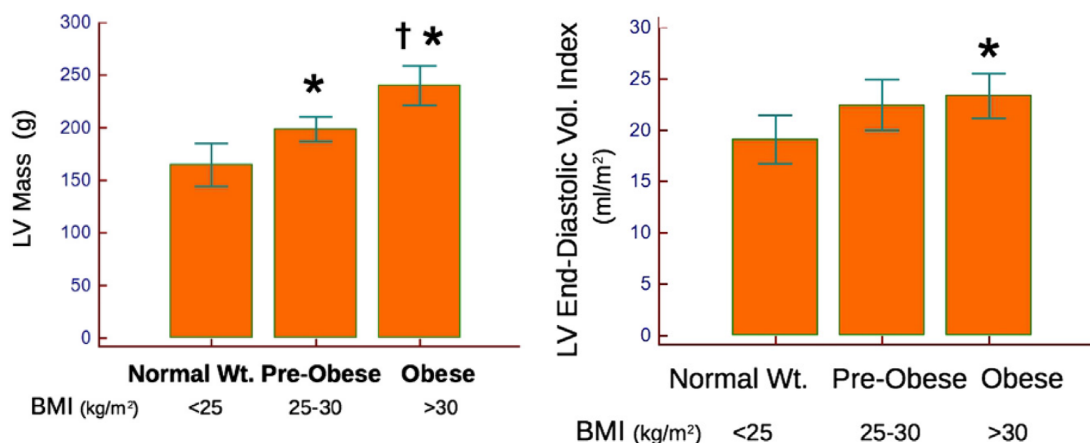

**Figure 3-2 (left) and 3-3 (right): Impact of BMI on LV Mass and volume**

Each panel shows mean for unadjusted LV mass and end-diastolic volume index, in each of the 3 BMI classes. Overall p value for hypertrophic cardiomyopathy patients was 0.005 (obese patients  $p < 0.05$  vs. each of the other 2 groups). \* $p < 0.05$  versus normal weight; † $p < 0.05$  versus pre-obese.

The heart of obese patients in the general population is characterized by profound remodeling of the LV, with chamber enlargement and greater end-diastolic volume, which are the primary cause of mass increase[18-20]. Nevertheless, preserved systolic function allows the stroke volume to remain normal, ensuring an adequate blood supply even in the presence of increased oxygen requirement [Figure 3-4]. Therefore, such changes are an obligate consequence of obesity and reflect a physiologic adaptation to increased body weight, triggered by the hemodynamic and neurohormonal pathways of secondary hypertrophy.

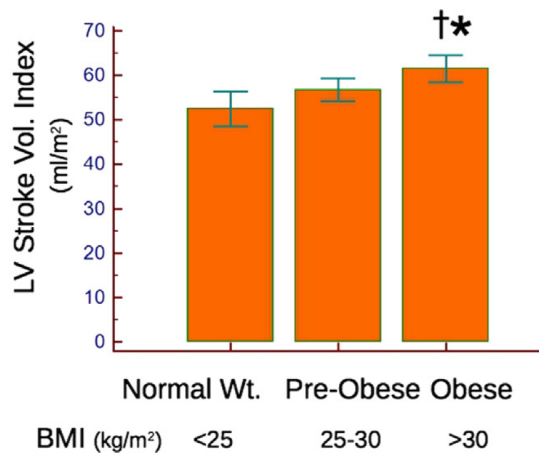

**Figure 3-4: Impact of BMI on LV stroke volume**

This panel shows mean for LV stroke volume index, in each of the 3 BMI classes. Overall p value for hypertrophic cardiomyopathy patients was 0.005 (obese patients  $p < 0.05$  vs. each of the other 2 groups). \* $p < 0.05$  versus normal weight; † $p < 0.05$  versus pre-obese.

Notably, in our cohort the absolute LV wall thickness was unaffected by body weight, suggesting that the degree of regional and asymmetrical hypertrophy, distinct feature of HCM, is primarily driven by genetic factors and remain largely unaffected by environmental modulation. Therefore, neither the current clinical diagnostic criteria for HCM [3] nor decision-making for primary prevention of sudden death with implantable cardioverter-defibrillators (both based on maximum absolute LV wall thickness) require adjustment with respect to BMI in adult.

Myocardial fibrosis, represented by areas of late gadolinium enhancement (LGE) at CMR, was more prevalent in obese and pre-obese patients. However, average percentage of fibrosis, expressed as % of LV mass occupied by LGE, was comparable among the subgroups. The multivariate model identified four variables as independently associated with an increased LV mass: showed BMI, male sex, hypertension and outflow obstruction. In particular pre-obese and obese HCM patients showed respectively a 65% and 300% increased likelihood of assignment to the highest LV mass index quartile.

Not only the cardiac morphology and function, but also the outcome was related to the BMI class. Although all-cause mortality did not differ among the three different subgroups, obese patients who were alive at the end of follow-up showed an increased risk of developing severe functional limitation (NYHA functional class III to IV - HR 3.6) [Figures 3-5 and 3-6]. However, the presence of severe symptoms was not due to progressive systolic dysfunction (the so-called “end-stage HCM”), since mean ejection fraction of the obese patients remains in the normal range. Therefore, it is challenging to ascertain whether the functional

limitation was directly related to obesity or to the presence of HCM. Both these factors may be closely related and embraced in a negative cycle of event in which obesity leads to a sedentary life-style, further increases in BMI, and, ultimately, worsening of heart failure symptoms.

Despite the impact on symptomatic status, the presence of obesity itself did not confer a survival disadvantage in patients with HCM. While this is partially counterintuitive, it is in line with the well know phenomenon of “obesity paradox”, which states that, in patients with chronic heart disease, the presence of obesity is a strong predictor of favorable outcome [21]. Conversely, in the general population, obesity is associated with increased mortality and morbidity [11, 17, 22].

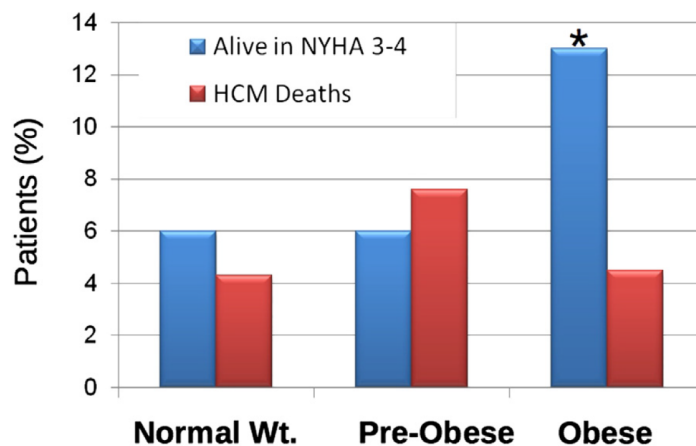

**Figure 3-5: Prevalence of HCM-related mortality and severe heart failure symptoms (NYHA functional classes III or IV) among survivors at the end of follow-up period**

HCM: hypertrophic cardiomyopathy; NYHA: New York Heart Association; Wt: weight. CMR. cardiac magnetic resonance

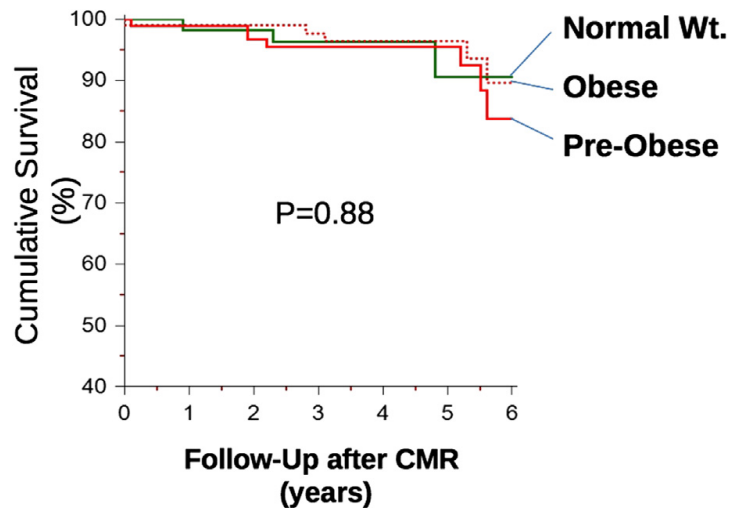

**Figure 3-6: Cumulative risk of all-cause mortality in normal weight, pre-obese, and obese patients during follow-up**

(Abbreviations as in figure 3.5)

HCM is a genetic-determined cardiac disease, whose phenotype was thought to be entirely the expression of sarcomeric mutations. This study proved, for the first time, that phenotype and outcome of patients with a genetically determined cardiac hypertrophy can be modulated and influenced by environmental and modifiable factors such as obesity. These data also raise the possibility that control of modifiable risk factors may be beneficial to cardiomyopathy, although further study are mandatory in order to determine whether reduction of BMI could lead to an improvement in clinical course.

Beyond the understanding of the physiopathological mechanisms leading to a different phenotypic expression of the disease, this data may be useful in our everyday clinical practice. Nowadays the primary target in the treatment of HCM is symptoms relief, since neither drugs nor surgery capable of treating the disease itself are currently available [23]. Therapy usually employed to relief symptoms in HCM might be effective when targeting hemodynamic alterations. In obese HCM patients, symptoms may be caused not only by the hemodynamic changes, but mostly by



deconditioning and excess oxygen requirements, which are primarily related to the obesity. In that case, both medical and even invasive therapies risk to be ineffective and could have a limited impact on symptoms.

So, when treating an obese patient with HCM and deciding whether to start, increase, or decrease therapy, it is extremely important taking into account that his symptoms are the result of the balance between hemodynamics and excess body weight. Yet, treating the hemodynamic abnormalities will lead to less than satisfying results unless weight loss and healthy habits are taught to and adopted by the patients.

Readers with sharp eyes would have noticed that only a minority of patients enrolled was in the normal weight range, like HCM and obesity were somehow related. However, the challenging question is: which one comes first? Is it a more severe expression of HCM that leads to obesity, or is it the general trend of increasing body weight in Western society that complicates HCM? The cross-sectional design of the study didn't allow the understanding of this association. However, both patients and physicians should be aware of the negative implications of obesity in outcome of HCM and should therefore prevent it. The inappropriate suggestion to avoid physical exercise arises from the fact that the incidence of sudden cardiac death in HCM patients involved in competitive sports is much higher than in those who are not. However, the extension of such recommendation to regular, non-competitive exercise might lead to an unhealthy lifestyle, including weight gain and increased cardiovascular risk.

*Full text of the publication may be found in chapter 7.*



***4. Natural History and Predictors  
of Outcome***

---

#### *4. Natural History and Predictors of Outcome*

*“Risk stratification for any disease is, in many ways,  
medicine’s attempt to predict the future”.*

*Rod Passman and Jeffrey J. Goldberger*

## **4.1 Predicting the Risk of Sudden Cardiac Death using Cardiac Magnetic Resonance**

Risk stratification for sudden cardiac death (SCD) has always been painful for cardiologists, especially for those involved in the field of cardiomyopathies. Cardiomyopathies are disease of the heart muscle with high arrhythmogenic propensity, usually affecting young subjects and entire families. SCD is the most visible and devastating complication of cardiomyopathies and the attempt to stratify patients, identifying those who are at higher risk for malignant arrhythmias, is difficult. Although the huge amount of risk factors individuated and the effort to assemble risk score system, the issue of risk stratification and prevention of SCD remains incomplete and very far from perfect [1-10]. The need to better stratify patients, with the aspiration to prevent SCD, has been realized with the systematic use of implantable cardioverter defibrillators (ICDs) only in the past 10 years.

Estimates of the SCD rate in HCM emerged from hospital-based cohorts were as high as 6%/year. This incredibly high incidence of SCD is now recognized as an overestimate, was based on data collected in tertiary center contaminated by the preferential referral of high-risk patients. Recent reports, originated from less selected regional or community-based cohorts placed annual HCM mortality rates at a much more realistic  $\leq 1\%$ . Nevertheless, the traditional profile of SCD in HCM remains unchanged; that is, it usually occurs without warning in asymptomatic or mildly symptomatic young patients (predominantly <25 years of age).

While is now universally accepted the need for secondary prevention with ICDs for patients who have survived a cardiac arrest with

#### *4. Natural History and Predictors of Outcome*

documented VF or an episode of sustained VT [12, 13], there has been a substantial effort in reliably identifying the relatively small subset of patients within the wide HCM spectrum who are at unacceptably high risk for SCD and could benefit for ICD in primary prevention.

The conventional primary prevention risk factors in HCM, are [14]:

- (1) family history of  $\geq 1$  HCM-related SCDs;
- (2)  $\geq 1$  episode of unexplained, recent syncope;
- (3) massive LV hypertrophy (thickness  $\geq 30$  mm);
- (4) frequent nonsustained VT on serial ambulatory 24-h Holter;
- (5) hypotensive or attenuated blood pressure response to exercise

Furthermore, certain morphological and functional features of HCM can contribute to risk stratification, since they are known to be associated with higher risk of arrhythmic event:

(1) LV Apical Aneurysms: the fibrotic thin-walled aneurysm, which is usually present in patients with mid-ventricular obstruction, creates the arrhythmogenic substrate triggering VT and VF [15].

(2) End-stage disease: this small subset of patients (around 5% of HCM population) develops a systolic dysfunction characterized by wall thinning and cavity dilatation, due to a widespread and often transmural LV scarring. Inevitably, an adverse clinical course with progressive heart failure and atrial and ventricular tachyarrhythmias occurs [16].

(3) LV Outflow Obstruction: a gradient  $\geq 30$  mmHg at rest is a quantitative measure of elevated intraventricular pressure and wall stress. Some studies showed that obstruction had a very modest, though statistically significant, relationship to SCD risk [17, 18].

#### *4. Natural History and Predictors of Outcome*

(4) Percutaneous Alcohol Septal Ablation: this is a technique used as an alternative therapeutic strategy for selected obstructive HCM patients to the preferred option of surgical myectomy. It has the capability of reducing the LV outflow gradient by creating a transmural scar by alcohol injection in a septal coronary artery. There is accumulating evidence and concern that the potential arrhythmogenicity of the scar created by alcohol septal ablation can augment risk in the HCM population [19, 20].

(5) Genotype: Although now commercially available, genetic testing has not achieved the initial expectation that it would become a reliable strategy for predicting prognosis or selecting patients for primary prevention ICDs. However, the presence of multiple mutations, with the hypothesis of “gene dosage effect”, has been proved to be associated with higher risk of negative outcome, especially development of systolic dysfunction [21].

Because current risk stratification cannot precisely guide SCD prevention for each HCM patient, and SCD is known to occur in occasional patients without any conventional risk factors, there is the ongoing aspiration to identify more sensitive and specific clinical markers. Ideally, this would lead to a single, noninvasive, repeatable and accurate quantitative test.

Ventricular tachyarrhythmias, emanating from regions of structurally abnormal myocardium (including areas of disorganized architecture and myocardial fibrosis), represent the likely mechanism of SD in HCM [22, 23]. Contrast-enhanced cardiovascular magnetic resonance (CMR) imaging with late gadolinium enhancement (LGE) is capable of noninvasive identification of myocardial fibrosis. While recent investigations in HCM have demonstrated strong association between the

presence of LGE and ventricular tachyarrhythmias, the utility of LGE as a predictor of SD events remains unresolved [24-26].

Therefore, we have assembled a large multicenter HCM cohort to investigate the independent prognostic value of LGE with respect to SD and other adverse disease consequences. We prospectively evaluated 1300 HCM patients presenting to 7 HCM centers. HCM patients at each institution consecutively eligible for CMR imaging comprised the initial study cohort.

#### **4.1.1 Extension of LGE as a powerful predictor of SCD**

Most of the contrast-enhanced CMR studies in HCM have focused almost entirely on the association between presence of LGE and SD. However, the mere presence of any amount of LGE cannot be regarded as a risk marker, since this designation gives equal weight to LGE across a broad spectrum of amounts, from minimal to extensive [25]. Furthermore, attributing increased risk to the presence of LGE per se conveys an impractical and also imprudent message, since in some studies up to 70% of all HCM patients have some LGE [26], all of whom could be regarded as potential candidates for primary prevention ICDs, including a very large proportion who would not benefit from this therapy and could be exposed only to potential device complications.

Indeed, our data showed that SD risk increased in direct relation to extent of LGE, with 10% increase in LGE associated with 40% increase in relative SD risk. Notably, LGE  $\geq 20\%$  conferred a 2-fold greater risk compared to the absence of LGE [Figure 4.1-1]. Multivariable analysis identified extent of LGE as a strong independent predictor of SD, independent of patient age, and of all cause mortality ( $p=0.007$ ).



#### 4. Natural History and Predictors of Outcome

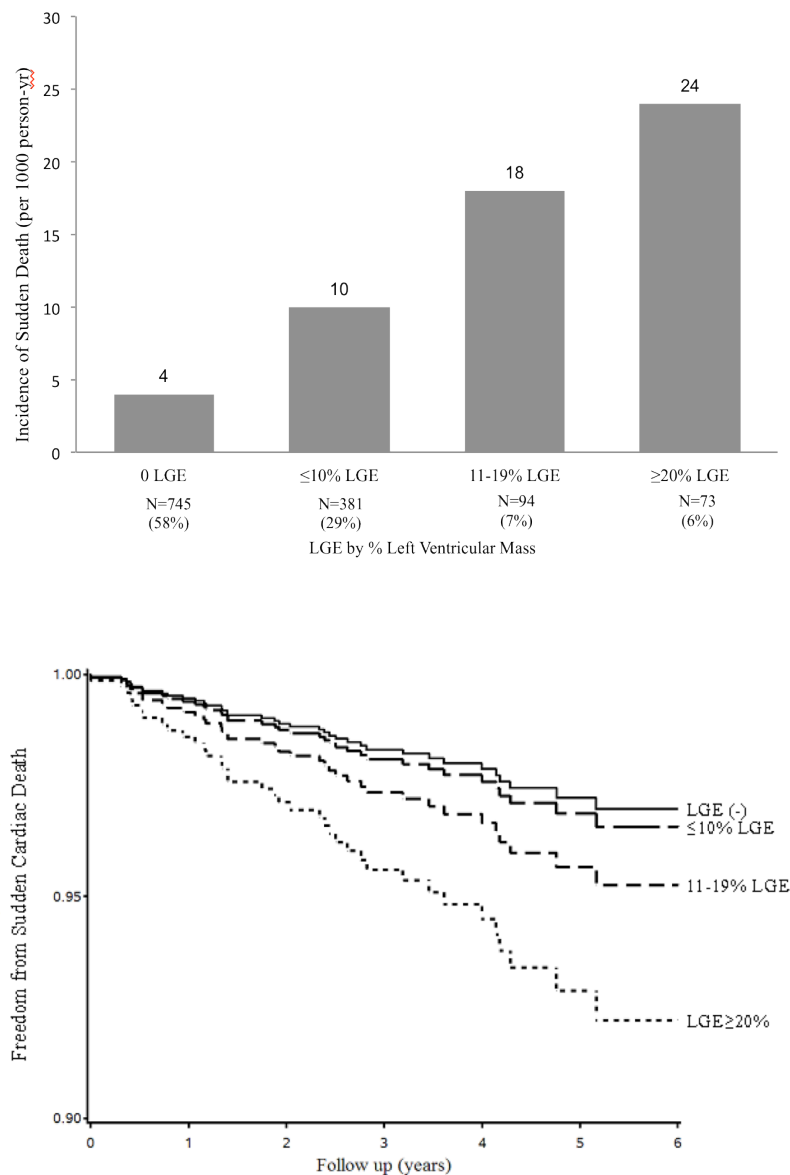

**Figure 4.1-1. Relation between extent of late gadolinium enhancement (LGE) and sudden death (SD) in 1293 patients with HCM.**

*Top panel:* Incidence of SD events increased progressively and in direct relation to extent of LGE ( $p < 0.001$  for chi-square trend test).

*Bottom panel:* Hazard plot based on multivariable Cox regression analysis ( $p = 0.02$ ).

More than half patients with SD events had none of the conventional risk markers. Among these patients, SD risk increased in direct proportion to extent of LGE, with 20% LGE conferring nearly a 3-fold greater risk of SCD [Figure 4.1-2]. Therefore, extensive LGE provided

#### 4. Natural History and Predictors of Outcome

the only opportunity to identify some young asymptomatic patients otherwise not regarded at increased risk, given absence of conventional risk markers, and who would have remained unprotected against SD without an ICD. Since approximately one-half of all clinically identified HCM patients do not have conventional risk factors [27], CMR could potentially identify a number of otherwise under-recognized patients at increased risk who would potentially benefit from this enhanced risk stratification model.

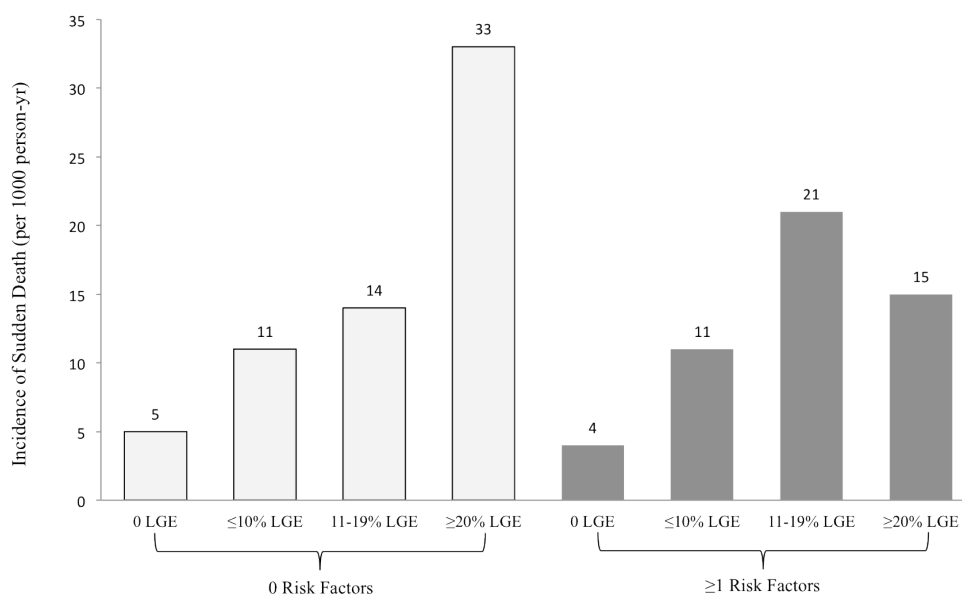

**Figure 4.1-2: Relation between extent of LGE, conventional risk factors, and sudden death risk in 1293 patients with HCM.**

Incidence of sudden death events increased progressively with increasing amounts of LGE in patients without conventional risk factors, while in HCM patients with  $\geq 1$  risk factor the incidence of sudden death events was highest in patients with  $>10\%$  LGE compared to those with less LGE.

Comparably, amongst all patients with  $\geq 1$  risk factors, sudden death risk increased in direct relation to the extent of LGE, with at least moderate amounts of LGE ( $\geq 10\%$ ), conferring a 30% increase in SD risk compared to those with no LGE. For patients in this “grey area” of HCM risk stratification, we found that LGE can act as a potential arbitrator for

#### *4. Natural History and Predictors of Outcome*

resolving ambiguous ICD decisions [Figure 4.1-2]. These data support a role for contrast enhanced CMR in more precisely defining patients at risk for SD, even in the presence of conventional risk factors, with important implications for ICD decision-making.

On the other hand, the absence of LGE was associated with a low risk of SD and a potential source of reassurance to patients. However, this finding did not absolutely immunize our patients against SD risk, suggesting that susceptibility to potentially lethal ventricular tachyarrhythmias can be influenced by factors other than myocardial fibrosis [28].

##### **4.1.2 Identification of progressive disease**

The present data also identified an association between marked and diffuse LGE and systolic dysfunction with progressive heart failure [Figure 4.1-3 A and 4.1-4].

The amount of LGE was greater in the 26 patients who developed end-stage during the follow-up compared to the 1206 HCM patients in whom systolic function remained normal. Therefore, such extensive LGE can be predictive of subsequent evolution into the end-stage, even when initially identified in patients with normal ejection fraction and without severe symptoms, with each 10% increase in LGE associated with 80% increase in relative risk of developing end-stage HCM. Indeed, there was a 3-fold increase in risk for end-stage progression when LGE was  $\geq 20\%$ . Notably, this same degree of fibrosis was also strongly associated with the much different risk for SD in HCM (usually in the absence of progressive heart failure), highlighting the power of extensive LGE as a noninvasive marker with dual value in predicting sudden death and end-stage HCM.

#### *4. Natural History and Predictors of Outcome*

The ability to prospectively identify patients who will progress to end-stage has clinical relevance. Indeed, this patient subset experiences an unpredictable clinical course associated with unfavorable (albeit treatable) disease consequences, including rapidly progressive heart failure, that require alteration in management strategies including tailored drugs and early consideration for heart transplant and prophylactic defibrillators [16].

On the other hand, advanced heart failure with normal EF (both with and without obstruction) was associated with no or small amounts of LGE, suggesting that myocardial fibrosis is not an important determinant of heart failure in the presence of preserved systolic function [Figure 4.1-3 B]. As expected, patients with progressive heart failure due to LV outflow obstruction showed a very low amount of LGE, of only 2%. From a physiopathological standpoint, this result is quite intuitive, since the heart muscle needs to be very efficient in order to create a significant outflow gradient.

4. Natural History and Predictors of Outcome

Figure 4.1-3 A-C: relationship between LGE and progression to End-Stage.

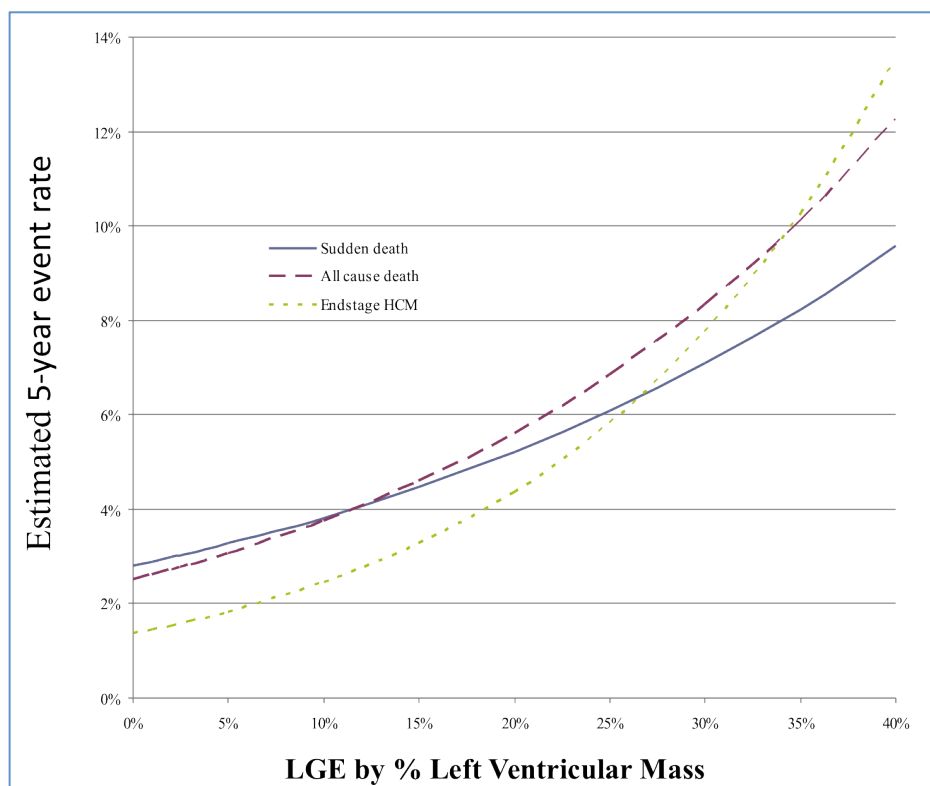
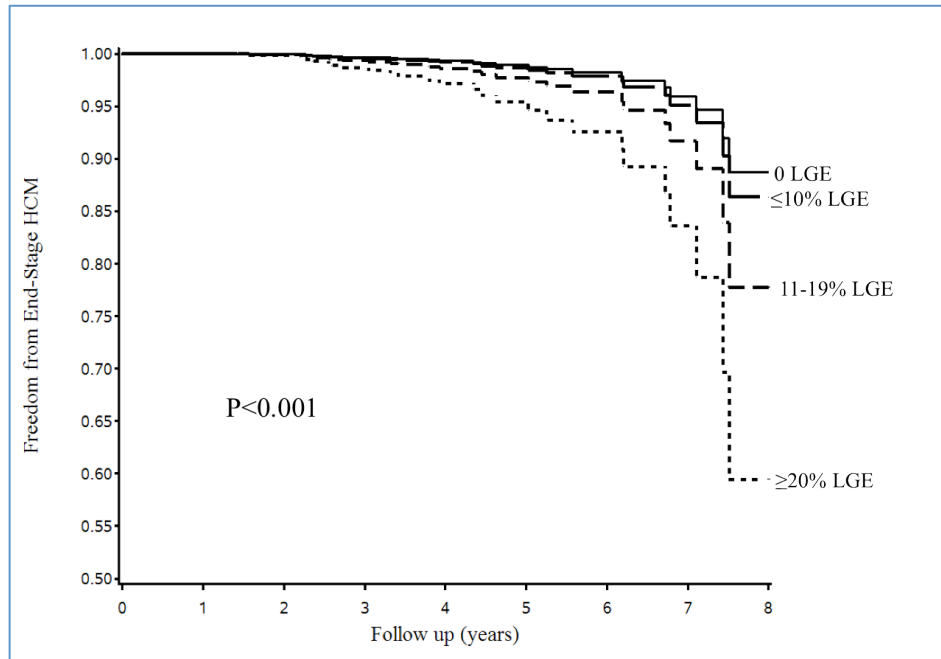

#### 4. Natural History and Predictors of Outcome

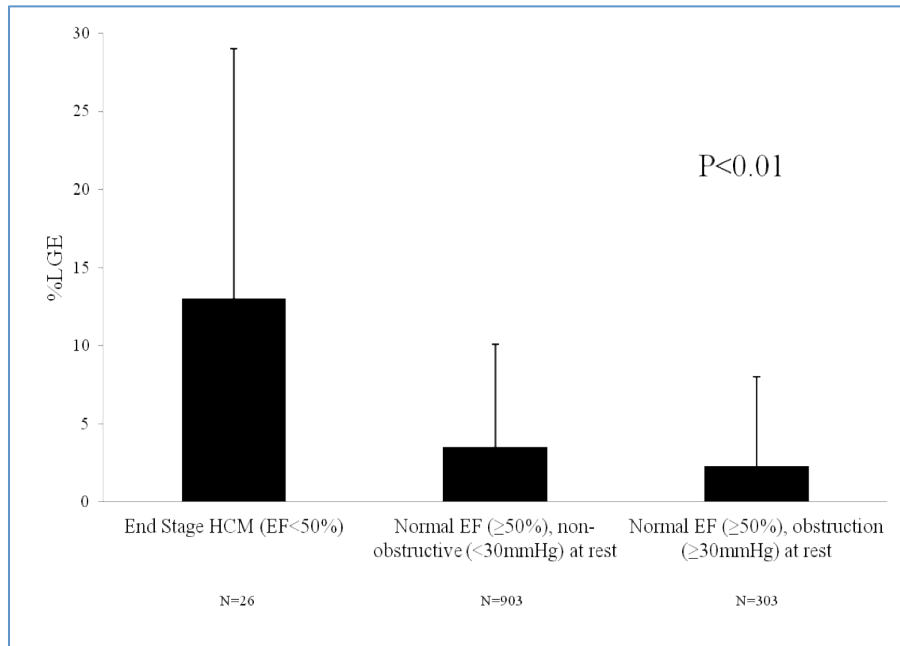
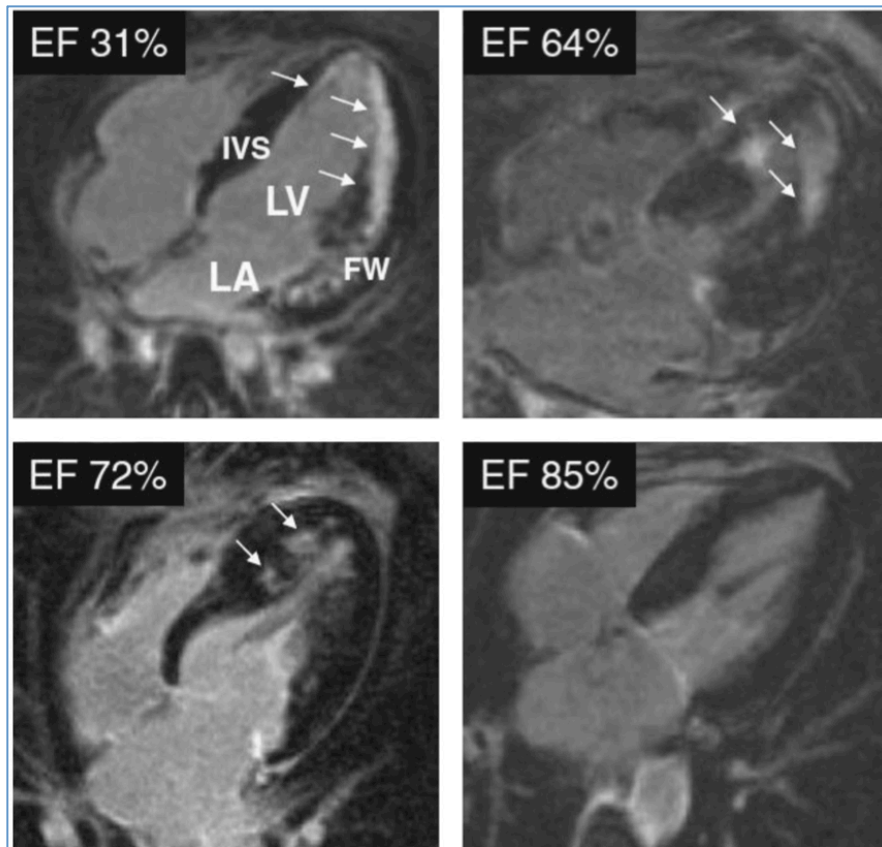

**Figure 4.1-3 A-C: relationship between LGE and progression to End-Stage.**

A. Hazard plot based on multivariable Cox regression showing the risk of developing the end-stage among 1232 HCM patients with normal systolic function at study entry. Incidence of end-stage development increased progressively with greater amounts of LGE ( $p<0.001$ )

B. Graph illustrating the strong relationship between the extent of LGE and the risk of progression to overt systolic dysfunction (end-stage), of all-cause death and sudden cardiac death.

C. Extent of LGE among 26 patients who developed end-stage HCM, 903 patients with normal EF without outflow obstruction, and 303 patients with normal EF and outflow obstruction ( $p<0.01$ ).



**Figure 4.1-4: LGE in 4-chamber vertical long-axis images of representative patients from the 4 LVEF categories.**

*Top left*, Twenty-year-old woman with end-stage progression showing extensive transmurular myocardial fibrosis (LGE occupying 43% of LV wall; arrows).

*Top right*, Sixty-one-year-old woman with low-normal EF showing transmurular LGE occupying 24% of the LV.

*Bottom left*, Thirty-five-year-old man with preserved systolic function showing limited nontransmurular fibrosis occupying 8% of the LV.

*Bottom right*, Forty-five–45-year-old man with supernormal systolic function showing absence of LGE.

#### 4.1.3 Utility of risk assessment in clinical decision-making

ICDs have partially changed the natural history of HCM for many patients and provided an opportunity to longevity [29]. Indeed, prevention of SCD has now become a new paradigm in the management of HCM.

Targeting candidates for prophylactic ICD therapy can be complex, due to the unpredictability of the arrhythmogenic substrate, the absence of a dominant risk factor, and difficulty in assembling randomized trials. Clinical dilemmas inevitably arise concerning ICD recommendations, because many HCM patients fall into ambiguous gray zones in which the level of risk cannot be assessed with precision using conventional risk factors, and a measure of individual clinical judgment and experience of the managing physician with direct knowledge of the patient's clinical profile and desires is necessary.

Implanting an ICD in primary prevention is not an easy call, nor for patients nor for physicians. Despite the advances in ICD technology, ICD-related complications are well documented and include infection, pocket hematoma, pneumothorax and venous thrombosis [11]. Furthermore, 25% of HCM patients experience inappropriate shocks (5%/year), resulting from lead fracture or dislodgement, oversensing, double counting and programming malfunctions, or when triggered improperly by sinus tachycardia or AF [11]. Unfortunately, the highest rate of complications is in younger HCM patients, largely because their activity level and body growth places a continual strain on the leads, which are regarded as the weakest point in the system.

The reputation of the ICD as a "shock box" may even push the patient to delay or refuse the device. Because of fear of present and/or future discharges, some patients increasingly limit their range of activities



#### *4. Natural History and Predictors of Outcome*

and inadvertently diminish the benefits of the ICD in terms of quality of life [30]. In such patients, especially those under the age of 50, the benefits of a life-saving device may be attenuated by symptoms of anxiety and depression due to significant difficulties in emotional adjustment after ICD implantation [30].

In conclusion, while the present data do not resolve all remaining questions in the arena of risk stratification in HCM, the imaging capability of contrast-enhanced CMR with extensive LGE advances the risk stratification strategy in HCM by providing the opportunity to identify additional patients at increased SCD risk in whom prophylactic ICD therapy would otherwise not be considered. Conversely, the absence of LGE was associated with lower SCD risk. In addition, extensive LGE was also predictive of adverse LV remodeling with systolic dysfunction (endstage) and therefore is associated with 2 diverse consequences of HCM. These novel findings support greater application of CMR in the routine clinical evaluation and risk stratification of patients with HCM.

## **4.2 A hundred tales the blood can tell: NT-pro BNP as a clinical barometer of disease stability in HCM**

There is an embarrassing gap between the availability of information derived from serum biomarkers and our ability to understand their true significance in order to create appropriate personalized remedies.

Natriuretic peptides have been validated as markers of severity and decompensation in various cardiac disorders and represent powerful predictors of outcome in heart failure [31, 32]. The value of BNP or NT-proBNP to identify those at highest risk for adverse outcome, has led to the concept of using measurement of these biomarkers to 'monitor' and 'guide' adequacy of therapy. They have also been useful as screening tools in large populations at risk of developing cardiovascular events, including diabetic and elderly patients [32].

NT-proBNP, the N-terminal part of the BNP pro-hormone, is released during hemodynamic stress by stretched cardiac myocytes and split by proteolytic enzymes into 2 peptides; the C-terminal fragment (BNP) represents the biologically active hormone [31, 33]. Because of a different clearance mechanism (renal for NT-proBNP and receptor mediated for BNP), NT-proBNP represents a more reliable predictor of outcome than BNP [33].

To date, the prognostic accuracy of natriuretic peptides in patients with hypertrophic cardiomyopathy (HCM), the most common genetic heart disease, is unknown [34, 35]. Therefore, the serum NT-proBNP levels were determined in 218 consecutive outpatients with HCM who

had been referred to the Referral Center for Cardiomyopathies in Florence (Italy) before January 2011.

##### 4.2.1 Enrollment of patients and clinical follow-up

Of the 218 patients, 35 with known coronary artery disease (n=15) or evidence of systolic dysfunction at the first evaluation (defined as a LV ejection fraction <50%; n=20) were excluded. The remaining 183 patients with HC constituted the study group enrolled in the present project. All had had a stable clinical course, without episodes of acute HF or worsening of symptoms, in the previous 3 months.

After enrollment, the patients were evaluated annually or more often if dictated by the clinical status, using 12-lead electrocardiography, echocardiography, and 24-hour electrocardiographic Holter monitoring. Therapy was prescribed as appropriate, according to the current HCM guidelines.

The *primary end point* (PE) was defined as a composite of cardiovascular death (including sudden cardiac death), heart transplantation, and resuscitated cardiac arrest.

The *secondary end point* (SE) was a composite of HF-related events, including HF death, pulmonary edema requiring hospitalization, progression to advanced symptomatic status (New York Heart Association class III or IV), end-stage disease, onset of atrial fibrillation, and stroke.

#### 4.2.2 Results

The median NT-ProBNP value for the study group was 615 pg/ml (range 22 to 16,013). Patients in the upper tertile, with higher NT-proBNP values, had a larger left atrial diameter and maximum LV wall thickness and were more likely to have advanced symptoms (New York Heart Association class III), atrial fibrillation, and dynamic LV outflow tract obstruction. The women had greater NT-proBNP values than the men and represented most patients in the upper tertile. These data are in agreement with those derived from previous studies, confirming that NT-proBNP values correlate with the degree of symptomatic impairment and functional capacity, LV mass index, left atrial volume, and LV outflow tract obstruction [36-38].

In our HC cohort, followed up for an average of almost 4 years, NT-proBNP proved to be an independent predictor of cardiovascular mortality (our primary end point), with a six-fold increase in the likelihood for each increment in the log NT-proBNP [Figure 4.2-1]. The cumulative rate of the primary end point at the end of the follow-up period was 5% (1.3%/yr) and 8% (2.1%/yr) in the middle and upper tertile, respectively. Furthermore, the presence of a restrictive LV filling pattern conferred additional prognostic stratification for patients in the middle NT-proBNP tertile, although it had no additional value for patients in the upper tertile.

In the present analysis, however, sudden death represented a potential confounder with regard to the predictive values of NT-proBNP, because life-threatening ventricular arrhythmias can occur in stable and often asymptomatic or only mildly symptomatic patients, lacking LV overload and hemodynamic decompensation at death and, thus, might not be predictable using the biomarkers of HF.

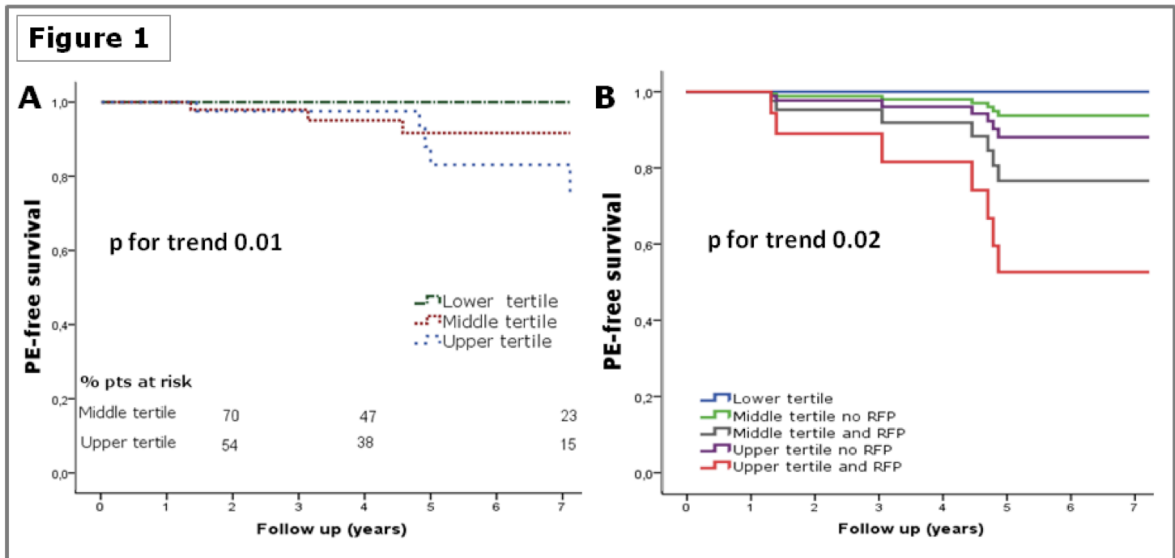
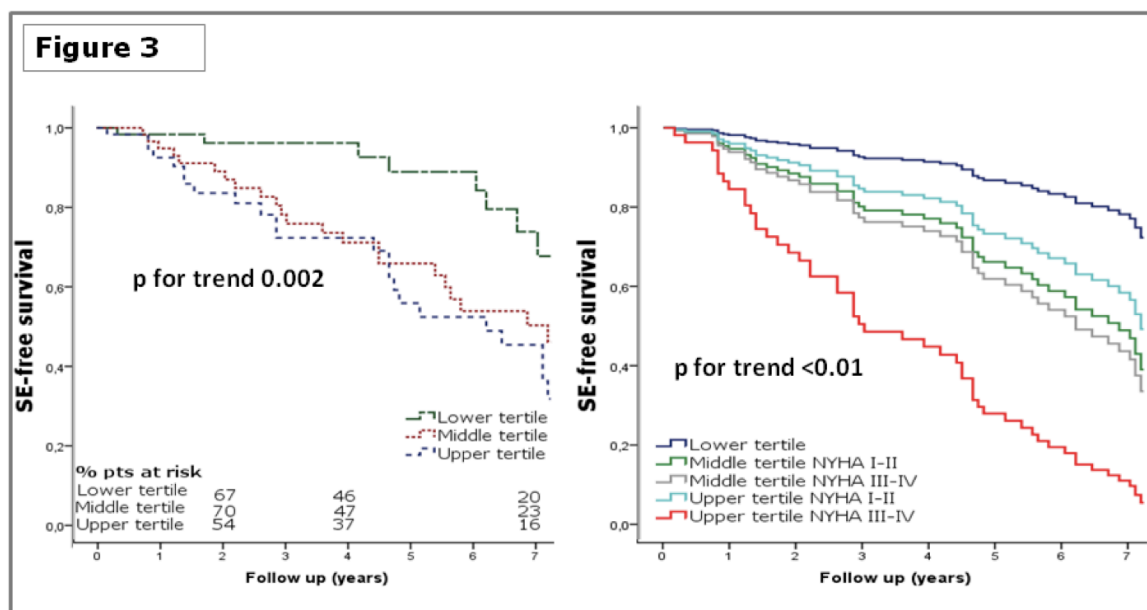

**Figure 4.2-1.**

(A) Survival free from the primary end point (PE; a composite of cardiovascular death, heart transplantation, and resuscitated cardiac arrest) stratified by NT-proBNP tertiles (overall log-rank  $p \leq 0.01$ ). After pairwise comparison with Bonferroni correction, only the lower to upper tertile comparison reached statistical significance ( $p \leq 0.01$ ; HR 9.26, 95% CI 1.58 to 53.9).

(B) Freedom from PE stratified by NT-proBNP tertiles and presence or absence of mitral pulsed wave restrictive filling pattern (RFP).

The secondary end point, specifically focused on HF-related events, was more accurately predicted by the NT-proBNP levels, with favorable rate of survival free from the SE in the lower NT-proBNP tertile compared with the middle and upper tertiles [Figure 4.2-2]. The cumulative rates of SE were 18% (4.6%/yr) in the lower, 47% (12.0%/yr) in the middle and 44% (11.2%/yr) in the upper tertile. With regard to the SE, the presence of congestive symptoms at enrollment (expressed as New York Heart Association functional class) significantly contributed to the risk stratification of patients within the middle and upper NT-proBNP tertiles [Figure 4.2-2].



**Figure 4.4-2.**

(A) Survival free from the SE (a composite of HF death, acute decompensation, progression to end-stage disease, and stroke) stratified by NT-proBNP tertiles (overall log-rank  $p \leq 0.002$ ). After Bonferroni correction, the lower to middle and lower to upper tertile comparisons reached statistical significance ( $p \leq 0.001$  and  $p \leq 0.002$ , respectively).

(B) In a Cox regression model including other independent predictors of SE, only the initial New York Heart Association (NYHA) functional class helped to further stratify high-risk patients.

Receiver operating characteristic curve analysis demonstrated moderate power for NT-proBNP in the prediction of the primary and secondary end point [Figure 4.2-3].

The relatively high NT-proBNP value of 810 pg/ml proved the best cutoff for the identification of patients at risk of cardiovascular death (PE), although with limited specificity (61%). Comparably, an NT-proBNP level  $<310$  pg/ml was associated with a 75% reduction in risk of HF-related events compared with values of  $>310$  pg/ml [Figure 4.2-3], with high sensitivity (85%) but low specificity (45%).

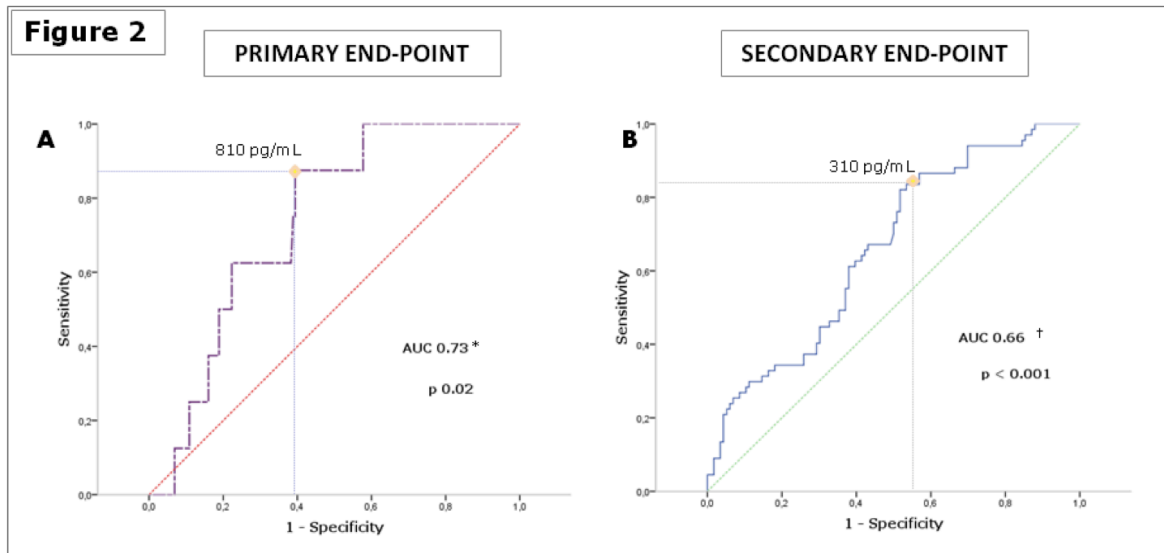

**Figure 4.2-3.**

Receiver operating characteristic curves evaluating accuracy of NT-proBNP levels for prediction of (A) primary end point and (B) SE. \*95% CI 0.61 to 0.86; †95% CI 0.58 to 0.74.

The threshold of 310 pg/ml, representing the cutoff value for the lower tertile, had very high negative predictive accuracy (85%) and retained important prognostic value even after adjustment for other powerful adverse clinical features, such as age, New York Heart Association functional class, and LV outflow tract obstruction. Similarly, the positive predictive accuracy for end-stage progression was low (25%), despite an excellent negative predictive value (88%).

Therefore, NT-proBNP appeared most useful for its high negative predictive value, as a screening test to identify low-risk patients, rather than to single out those with a greater risk of events.

#### 4.2.3 Understanding the language of serum biomarkers

In stable outpatients with HC, plasma NT-proBNP proved a powerful independent predictor of death and HF-related events. While

#### *4. Natural History and Predictors of Outcome*

the positive predictive accuracy of the elevated NT-proBNP values was modest, low values reflected true clinical stability,

Low NT-proBNP values can identify truly stable disease and allow cautious reassurance of patients with HC regarding the risk of disease progression and HF, even in the presence of potentially adverse clinical features, suggesting the possibility of avoiding or postponing aggressive treatment options. For patients with HC and dynamic LV outflow tract obstruction, for example, low NT-proBNP values might represent a useful arbitrator, supporting the decision to avoid or postpone invasive septal reduction therapies, particularly when the symptoms are sufficiently well-controlled by pharmacologic treatment.

In contrast, greater NT-proBNP values represent a rather nonspecific “red flag,” lacking sufficient specificity for the identification of the truly high-risk subset, and needs to be complemented by additional clinical and instrumental workup.



### **4.3 Long term outcome of idiopathic dilated cardiomyopathy: the real world**

Idiopathic dilated cardiomyopathy (IDCM) is a primary myocardial disease of unknown cause characterized by cardiac enlargement and impaired systolic function of one or both ventricles, in the absence of abnormal load conditions (such as hypertension, valve disease, or congenital heart disease) or coronary artery disease of sufficient severity to cause global impairment of ventricular function [39-41]. Different causes can lead to DCM, including inherited, infectious, and inflammatory diseases. However, the majority of cases remain unexplained after a thorough review for secondary cause. IDCM is an important cause of sudden cardiac death (SCD) and heart failure (HF) and is one of the leading indications for cardiac transplantation in children and adults worldwide [41].

Over the last three decades, the outcome of IDCM has radically changed due to major advances in pharmacological and device-based therapeutic strategies. However, studies addressing the outcome of HF have been characterized by patients with DCM, with a relatively small representation of individuals with IDCM, so that limited data exists with specific regard to this condition [42-45]. Furthermore, the everyday practice can be very different from that described in the trials, with rates of patient's compliance usually considerably lower than that reported in clinical trials [46-48].

The present study is based on a real clinical experience, whereby 603 patients with angiographically proven idiopathic dilated cardiomyopathy have been followed during the past 30 years in the Regional referral center for cardiomyopathies in Florence. This cohort of

unselected, consecutively enrolled and angiographically negative IDCM patients was evaluated in a systematic fashion by the same team, providing substantial continuity of care during an extended time period.

#### **4.3.1. Enrollment of patients and follow-up**

All study patients were evaluated and followed up at our institution by clinical and family history, physical examination, 12-lead ECG, standard chest radiograph, routine laboratory tests, 24-hour Holter ECG monitoring (since early 1980s), M-mode and 2D echocardiography (since 1970s), and Doppler echocardiography (since mid-1980s). Patients were regularly followed up by outpatient visits every 6 months (or more frequently when clinically indicated) and, when necessary, by interviews with referring physicians or by telephone contacts.

HF treatment has radically changed during the past decades, following major randomized clinical trials and their subsequent impact on international HF guidelines[44, 49]. The use of neurohormonal inhibitors has become established during the past 2 decades. While in the 1980s HF treatment was virtually confined to diuretics and digoxin, the 1990s have seen an explosion in the use of neurohormonal blockers.

Therefore, to assess long-term changes in outcome in relation to treatment options, we subdivided our patients with IDCM into 4 periods, coinciding with different therapeutic eras of HF treatment:

- period 1: 66 patients (11%) enrolled from 1977 to 1984, defined as the pre-ACE inhibition era, when standard therapy consisted of diuretic agents, digoxin, and early vasodilators;
- period 2: 102 patients (17%) enrolled from 1985 to 1990, marking the beginning of the ACEI era;

#### 4. Natural History and Predictors of Outcome

- period 3: 197 patients (33%) enrolled from 1991 to 2000, characterized by increasing use of ACEI and ARBs and the introduction of  $\beta$ -blockers;
- period 4: 238 patients (39%) enrolled from 2001 to 2011, the device-era, characterized by the introduction of ICD and CRT on top of extensive neurohormonal blockade

##### 4.3.2 Evolving treatment opportunities and outcome improvement

At initial evaluation, the 4 groups of patients were comparable with regard to sex and NYHA class. However, there was a slight trend toward enrollment of older patients, with less severe LV dilatation and dysfunction during the years, with permanent atrial fibrillation at initial diagnosis less prevalent over time.

At the end of follow-up, patients enrolled in periods 3 and 4 showed a better clinical profile, both in terms of cardiac function and symptoms. The improvement in systolic LV function, together with a reduction in end-diastolic diameter index, both expression of LV reverse remodeling, was paralleled by a clear improvement of functional status over time. Conversely, patients enrolled in periods 1 and 2 showed progression of symptoms and limited improvement in systolic function [Figure 4.3-1].

##### **Figure 4.3-1 (following page):**

Changes in New York Heart Association (NYHA) class [*top panel*], left ventricular ejection fraction (LVEF) [*middle panel*], and end-diastolic diameter index (iEDD) [*bottom panel*], from initial evaluation to end of follow-up based on enrollment period. Each bar indicates the change from enrollment (horizontal line) to final evaluation (blunt bar extremity).

#### 4. Natural History and Predictors of Outcome

