

Maurice Lévy's original contribution to the analysis of masonry domes

Giacomo Tempesta

Department of Architecture, University of Florence, Italy,
E-mail: giacomo.tempesta@unifi.it

Michele Paradiso

Department of Architecture, University of Florence, Italy
E-mail: michele.paradiso@unifi.it

Stefano Galassi

Department of Architecture, University of Florence, Italy
E-mail: stefanogalassi@hotmail.it

Eva Pieroni

Department of Architecture, University of Florence, Italy
E-mail: betulla.dt@alice.it

In the fourth section of his book “*La statique graphique et ses applications aux constructions*”, Chapter II, Cupoles en maçonnerie, published in Paris in 1888, Maurice Lévy deals with the problem related to the stability of masonry domes provided with variable thickness. Lévy's idea is based on the fact that in any type of dome there are two types of behaviour: the first refers to the portion of shell where, both along the meridians and parallels, there are only compressive stresses, the second relates to the part in which the parallels are in traction. The unknown of the problem is to determine the location of the parallel where the transition occurs between the two different conditions, that is, what Lévy calls the “*point neutre*”. Lévy suggests the use of an original graphical method, that he describes in detail, which initial setting is largely due to a previous work of H.T. Eddy.

Keywords: *masonry dome, graphical methods, limit analysis*

Introduzione

Some nineteenth-century scientific memoirs, published by the *Academiae Royale des Sciences* of Paris, formed the beginning of the studies concerning the equilibrium analysis of masonry domes. The problem was previously treated, from Vitruvius to Scamozzi, via Palladio and Leon Battista Alberti, only from a strictly geometrical point of view or, at most, only as a technical-constructive problem. Indeed, for a scientific approach that deals explicitly with the static problem of the masonry domes, supported by a rigorous mathematical reasoning, one needs to wait for 1734, the year in which Pierre Bouguer presented his memoir entitled “*Sur les lignes courbes qui sont propres à former les voutes en dôme*”. The first aspect of the problem to be examined was the search for the optimum shape to be given to a masonry dome loaded only by self-weight. The problem posed by Bouguer (defined as “*first question*” in the text

of his memoir) can be described as follows: which is that curve such that the surface generated by its rotation around a vertical axis, once it has been assigned an appropriate thickness, corresponds to a dome which is capable of supporting its own weight (fig. 1)? Imposing the assumption of complete absence of friction, Bouguer proposed for the first time the equation of the *funicular meridian*: he stated that, for the dome to be in equilibrium, the meridian curve must coincide with the funicular curve corresponding to the self-weight loads of a slice of the dome. In this regard, it should be remembered that some years earlier, in 1704, J. Bernoulli had shown that an arch with a shape of an inverted *catenary*, whatever its thickness, resists its own weight: the argument developed by Bouguer relies on the fact that a dome, which shape is obtained by rotating the *funicular meridian* around a vertical axis, has the same property of the arch analysed by Bernoulli. Later, Charles Bossut

(Bossut 1778), Lorenzo Mascheroni (Mascheroni 1785) and Giuseppe Venturoli (Venturoli 1883) reached similar conclusions. All the solutions suggested by these authors have a common characteristic: the dome is considered, *de facto*, as a one-dimensional behaviour structure, to be seen as composed of a series of distinct segments or slices or “lunes”, wider at the base and tapering to zero at the crown, placed in mutual contact with each other but without any interactions among them. In conclusion, since the equilibrium of each slice is investigated separately, if it can be shown that each element of the sliced structure is stable, then it is argued that the original structure must be stable. Under these assumptions the analysis of masonry domes does not present any difference compared with the analysis of masonry arches. The problem is, therefore, part of the investigations on the relationship between the shape of the *thrust curve* and the *catenary curve*, between the shape of a barrel vault and the *velaria*, between dome and the *hanging veil* “... un velo lento pendente da un cerchio orizzontale che senza rughe si disponesse per il proprio peso nella forma di un catino”.

It is interesting to note that the fact of not considering any action among the slices of the dome, corresponding to the hypothesis of zero hoop stresses, means that the problem lies, actually, in the field of modern limit analysis, as applied by J. Heyman (Heyman 1967) in

his fundamental studies on masonry structures. Moreover, in his introductory assumptions, Heyman himself makes explicit reference to the eighteenth-century model, considering that it was still perfectly suitable to deal with the general solution of the problem. The model of limit analysis proposed by Heyman does not differ in any way from the analysis performed by Poleni (Poleni 1734) or by the *Three Mathematicians* (Le Seur et al. 1742) for evaluating the stability of the dome of St. Peter in the Vatican. The similarity between the “*settore solido*” of Poleni and the “*orange slice*” of Heyman is very clear.

Later, directing the analysis to the study of the equilibrium of a spherical dome, Bouguer deals with the “*second question*”: how to determine the stress state in a dome with assigned thickness and shape. While the first problem mainly concerns the issue of the design of the dome, the latter is addressed to consider the aspects concerning the analysis of the stability of an existing dome. Both Bouguer and Venturoli, in this regard, introduce, although in a qualitative way, the issue of two-dimensional behaviour of the dome.

In 1888, the book “*La statique graphique et ses applications aux constructions*”, written by Maurice Lévy, is published. In the second chapter, entitled *Cupoles en maçonnerie*, Lévy deals with the stability of masonry domes provided with variable thickness (fig. 2). The

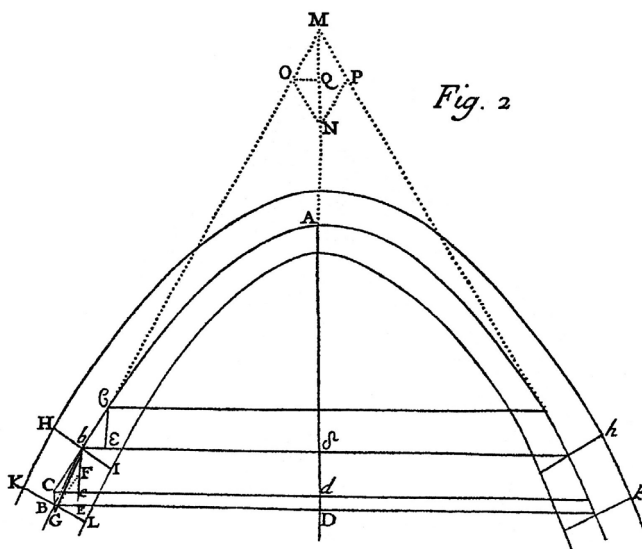

Fig. 2

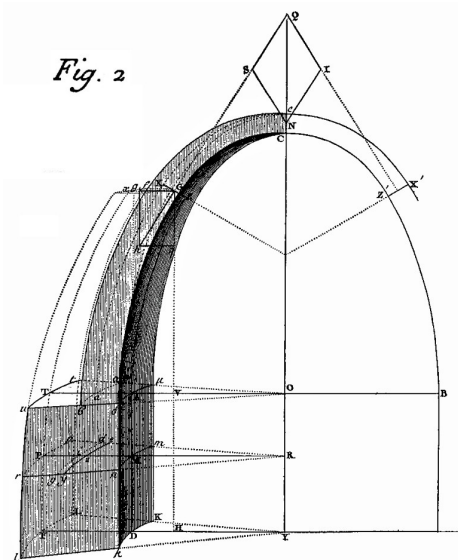

Fig. 2

Fig. 1. The funicular meridian of Bouguer (left) and the slice of dome analyzed by Bossut (right).

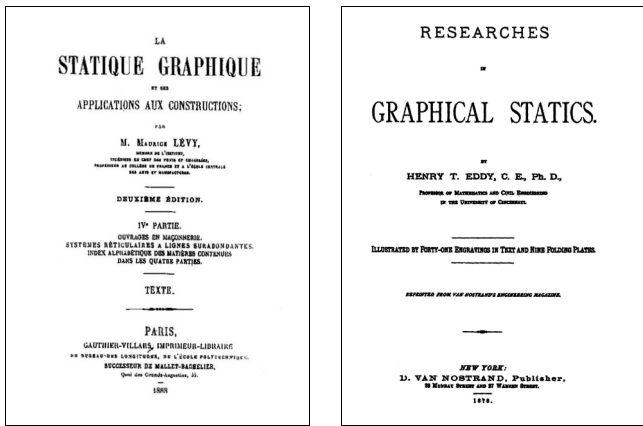

Fig. 2. Cover pages of the original texts of Lévy (left) and Eddy (right).

proposed method of analysis, absolutely original, is developed using a fully graphical procedure. The general hypotheses used by Lévy concern the absence of friction between the stones and the assumption of masonry as a no-tension material. Although it should be remembered that a good part of the discussion (the author makes a fleeting mention of this in the text) draws profusely on what has already been dealt with and resolved by H. T. Eddy in his book “*Researches in Graphical Statics*,” published in New York a few years before (fig. 2), Lévy suggests very clearly a new perspective in the analysis of masonry domes. Lévy’s idea is based on the fact that in any dome there are two types of behaviour: the first refers to the portion of shell where, both along the meridians and parallels, there are only compressive stresses; the second one relates to the part in which the parallels are subject to tensile stresses. The unknown of the problem is to determine the location of the parallel in which the hoop compressions vanish and the hoop tensions begin to develop. This is what Lévy calls the “*point neutre*”, because it is the hoop with zero tension. Since we must assume that the masonry cannot resist any hoop tensions, it follows that, below this point (i.e. in the lower portion of the dome) cracks will form and will be spread along the meridians.

Ultimately, the result is that the upper part of the dome will be carried, below this point, by the united action of a series of slices or masonry arch-lunes standing side by side (but acting independently from each other).

The double behaviour had already been hypothesized

by J. Wilhelm Schwedler (Schwedler 1859). In fact, Schwedler, around the mid-nineteenth century, proposed a graphical method for determining the state of stress in a dome (fig. 3).

Nevertheless, such a method does no more than to translate, in a graphical procedure, the solution that will be possible to obtain in general form, some years later, by the equations of the equilibrium of membranes, of membranes and also making the solution easier to obtain in the case in which the shape of the dome is not regular or which has a more complex curvature. Also in this case the proposed method involves the identification of two parts of the dome that have a different behaviour. In the graphical procedure, we accept the coincidence between the geometrical axis of the structure and the surface of stress of that part of the dome in which we have a bi-dimensional stress state; the axis changes only in the lower part of the dome, where the parallels would result stretched.

It would be nice to say that Schwedler was the first to introduce the double-masonry behaviour in the dome. However, the issue that had not yet been understood was that the inversion point of the hoop stresses is, actually, an unknown factor and can not be predetermined by saying, as Schwedler did, that it coincides with the point obtained by using the analysis of the membrane.

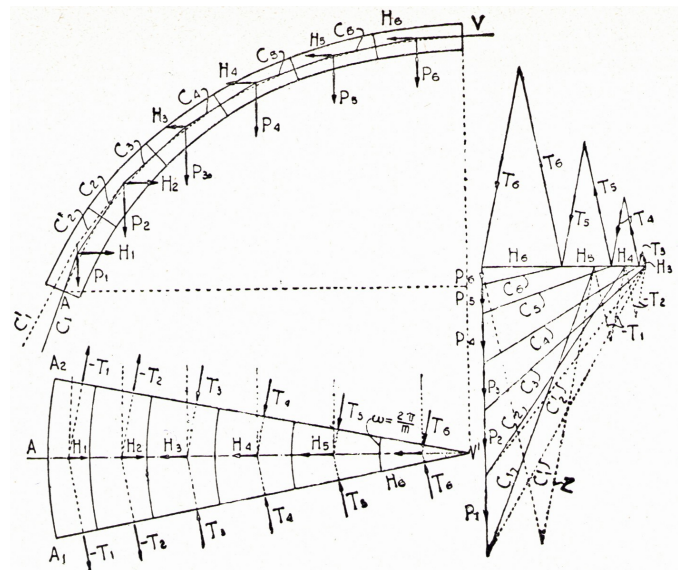

Fig. 3. Schwedler's graphical construction. The part of dome, which is not considered, is subject to non-admissible hoop stresses.

Lévy's graphical solution

As previously stated, the fundamental idea behind this procedure is based on the awareness of the existence of two unknown elements within the problem: the actual reacting structure and the location of the “*point neutre*” to which a “*parallèle neutre*” corresponds. Since masonry, for instance, is not capable of carrying tensile stresses, Lévy claims that the portion of the dome which is located above the “*point neutre*” tolerates the $q' d\theta$ horizontal compressive stresses that are transmitted by the adjacent sections of the vault, while the one located below such a point, cannot tolerate any hoop stress. In this instance, we do not assume an entirely one-dimensional behaviour on behalf of the dome, since we do not presumptively impose that the hoop stresses be neutral everywhere; Lévy takes into account the contribution that the hoop stresses give to the stability of the entire section of dome where such stresses are admissible, according to the mechanical characteristics of masonry material. By imposing the admissibility of such a solution in every area we obtain, as a fundamental consequence, the variation in distribution of the stress inside the entire vault. From this indetermination follows the inability to identify the location of the cracking joint, that is the “*point neutre*”. The latter is, therefore, the principal unknown factor regarding the analysis of a masonry dome: «*Il en résulte une tout autre*

répartition des pressions et, pour le point neutre, une position également autre que celle qui existerait dans une couple métallique de même forme. Il faut déterminer la nouvelle position de ce point».

Lévy also points out that the thrust line of that portion of the dome, which is located below the “*point neutre*”, can be nothing but the funicular curve associated to each sliced sector of the dome located under that point. This, of course, depends on the fact that underneath the “*point neutre*” the hoop stresses must be disregarded because they are inadmissible. In this regard Lévy states “*La partie de la Voûte comprise entre ce point et le joint de naissance ne supportant pas d'action sur ses têtes et étant, par suite, de tous points assimilable à une voûte en berceau ordinaire, sa courbe des pressions ne peut être qu'une courbe funiculaire des charges agissantes, tandis que la courbe des pressions de la partie supérieure peut, sans que les conditions statiques d'équilibre cessant d'être satisfaites, être prise à volonté à l'intérieur de la voûte*”.

The funicular curves are determined by using graphical static methods and, as mentioned above, an important part of the graphical procedure refers to the studies published in the United States some years before by H. T. Eddy. In brief, with referring to figure 4, the steps of the graphical procedure are:

- compute the weight of the blocks obtained by dividing the meridian cross section in a arbitrary num-

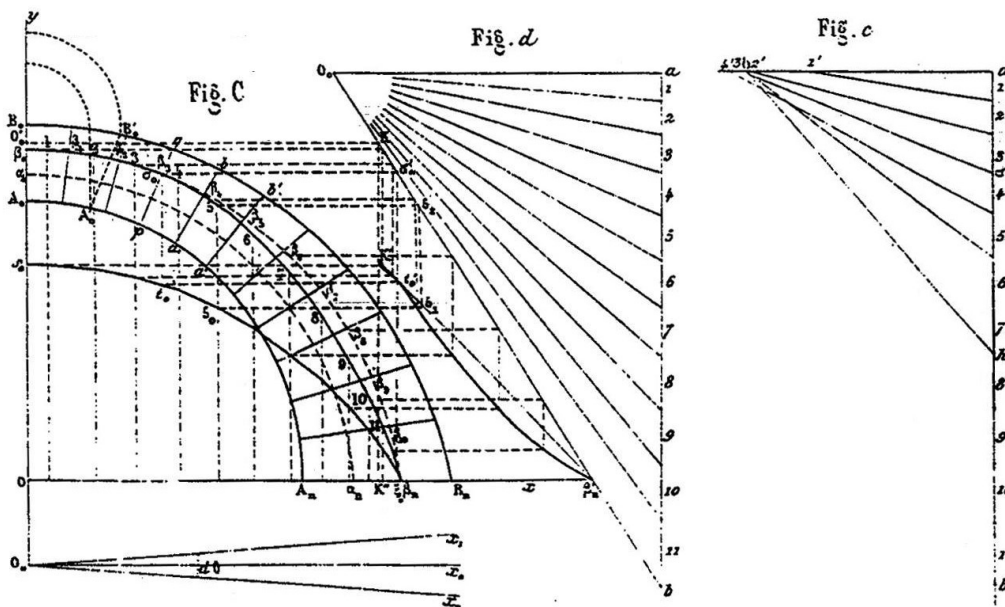

Fig. 4. Lévy's method. Graphical construction taken from “*La statique graphique et ses applications aux constructions*”, second chapter; *Cupoles en maçonnerie*.

ber of elements. The weights, for the calculation of which Guldino's Theorem is used, are acting on the vertical axes passing through the centre of mass of each element;

- draw a tentative funicular polygon which is obligated to pass through the extrados of the third middle at the base of the dome;
- draw the horizontal lines for the ordinates of the extrados of the third middle to meet the line O_0b of the tentative polygon;
- draw the vertical lines passing through the points determined above to meet the respective vertexes of the tentative funicular polygon; in such a way a curve which passes through the point β'_n is obtained;
- draw, passing through β'_n , a tangent to the curve: the point of tangency is t'_0 ; from that point; draw the horizontal line to meet the tentative funicular polygon in t_0 ;
- the vertical line, drawn from t_0 , intersects the extrados curve of the third middle in σ_0 ; this point represents the location of the parallel in which the hoop stresses are zero (*point neutre*), identifying the passage between the two parts of the dome that have different behaviour.

In order to draw the funicular curve relating to the lower portion of the dome, it is convenient to find the new polar distance. To identify this distance, let us draw, from O , a segment whose length $\overline{OO'_0}$ is equal to the $\overline{O_0a}$ polar distance. Then let us draw the horizontal line from this point until it reaches the line O_0b in K . Next, let us draw, from K , the vertical line that intercepts the line $\beta'_n t'_0$ in K' and the segment $O\beta'_n$ in K'' . The distance $\overline{K'K''}$, corresponding to the segment \overline{Oa} , represents, in the polygon of forces, the final polar distance. The funicular curve of the complete dome consists of two distinctive parts, one located above and one below the section in which the hoop stresses are zero. The actions exerted beyond σ_0 along the meridians are expressed by the polar radii drawn from O ; those exerted above σ_0 are expressed by the parallel lines to the edge $\beta_0\sigma_0$.

The graphical construction proposed by Eddy, to whom Lévy is largely in debt to, is not much different from that described above. Figure 5 shows the graphical construction in the case of a spherical dome with a constant thickness (Eddy 1878).

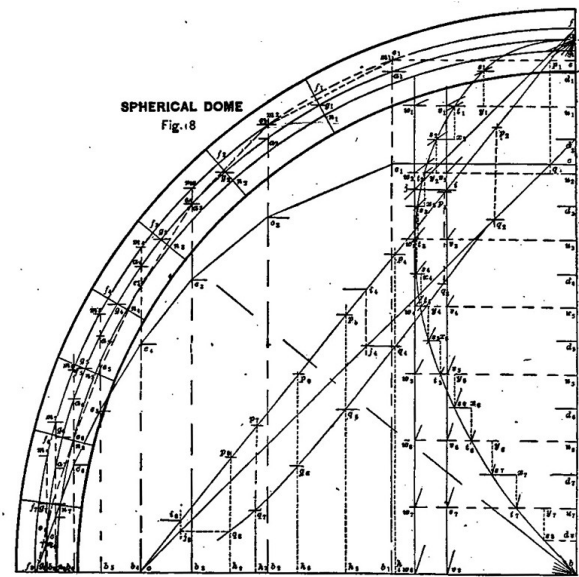

Figure 5 - Eddy's Graphical construction.

The analytical meaning of Levy's method

Analytically the solution may be obtained by defining two equations: the function $H_1(\varphi)$ which expresses the thrust of the upper part of the dome, and the function

$H_2(\varphi)$ which expresses the thrust (or funicular meridian) of the lower slice (Tempesta et al. 1998).

Firstly, in order to find equation $H_1(\varphi)$ we should determine the value of the angular coefficient of a generic line tangent to the dome extrados:

$$y'(x) = m1 = -\frac{x}{\sqrt{R_E^2 - x^2}} = -\frac{R_E \sin \varphi}{\sqrt{R_E^2 - R_E^2 \sin^2 \varphi}} = \tan \varphi \quad (1)$$

The equation of the generic line tangent to the dome extrados is therefore:

$$y - R_E \cos \varphi = -\tan \varphi (x - R_E \sin \varphi) \quad (2)$$

We shall then find the value of the angular coefficient of the generic line of the polygon of forces, that is parallel to the line of the previous equation. In order to achieve this, we shall determine the load (specific weight of the material set equal to 1) of the cup comprised between

the point 0 and a non-specified parallel identified by the φ angle.

$$P_1(\varphi) = \int_0^{\bar{x}} r \sqrt{1 + y'^2} dr = R^2 \int_0^{\phi} \sin \phi d\phi \tag{3}$$

The angular coefficient of the generic straight line is therefore:

$$m2 = - \frac{P_1(\varphi)}{H_1} = - \frac{R^2(1 - \cos \varphi)}{H_1} \tag{4}$$

Since the lines are parallel, the angular coefficients must be equal; by imposing the equality of the two expressions that we obtained, we derive the $H_1(\varphi)$ function, that is the equation that expresses the value of the thrust in every point of the polygon of the subsequent resultants of this tract:

$$m1 = m2 \rightarrow H_1(\varphi) = \frac{R^2(1 - \cos \varphi)}{\tan \varphi} \tag{5}$$

The equation of the thrust line in this lower part of the dome assumes the form:

$$H_2(\varphi) = \frac{R^2 \cos \varphi}{(- \tan \varphi_{n+1} - \tan \varphi)} \tag{6}$$

The “*point neutre*” can be obtained, as a function of the φ angle and the radius of curvature R , by the intersection between the curves represented by the two equations (fig. 6).

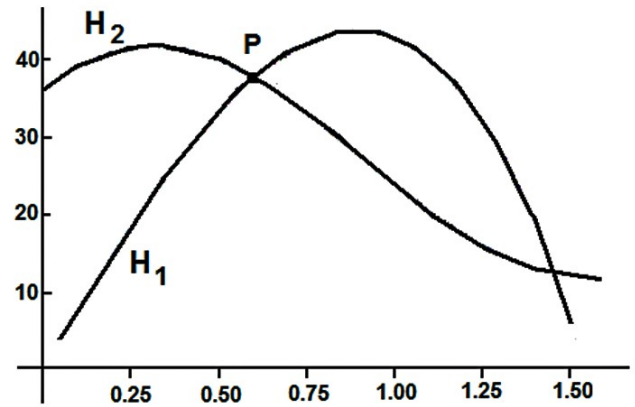

Fig. 6. The curves which represent the analytical functions H_1 and H_2 .

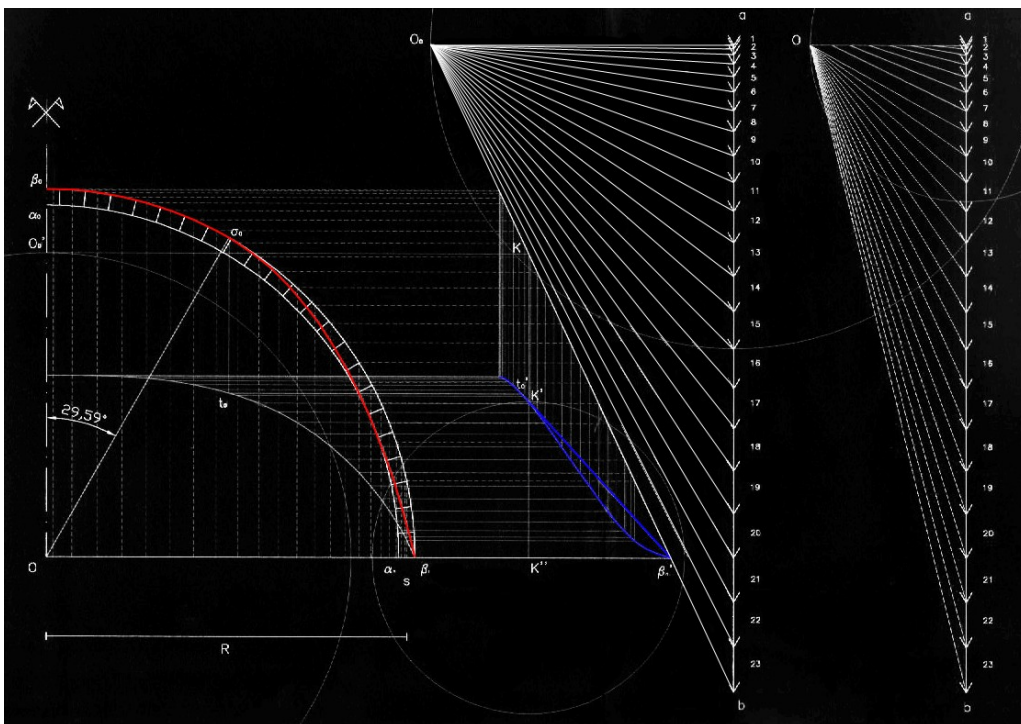

Fig. 7. Lévy's method. Example of graphical construction using Auto-Cad application.

Conclusions

In general, one can say that modern graphics editors make the graphical methods developed in the eighteenth and nineteenth centuries current again.

In the case of the graphical constructions proposed by Lévy and Eddy it is possible to obtain very accurate results for any masonry dome of any shape and curvature, considering also external loads due, for example, to the presence of a lantern on top of the dome.

Figure 7 shows a simple application of the graphical procedure for searching the limit thickness in the case of a spherical dome subject to self weight loads. The result is expressed in term of a ratio s/R , where s is the thickness and R is the medium radius of the curvature of the dome. It is obtained that the limit thickness is $s = 0.044 R$ and the “point neutre” is located at a φ angle equal to 29.59° . Such a solution is equivalent to that which one can achieve by using very sophisticated and complex numerical methods under the no-tension hypotheses.

References

- Bouguer, P. (1734). *Sur les lignes courbes qui sont propres à former les voûtes en dôme*, *Memoires. Academie Royale des Sciences*, 149-166.
- Poleni, G., (1734). *Memorie istoriche della Gran Cupola del tempio Vaticano*, Padova.
- Le Seur, T., Jacquier, F., and Boscovich, R., G., (1742). *Parere di Tre Matematici Sopra i danni, che si sono trovati nella cupola di San Pietro sul fine dell'anno MDCCXLII. Dato per ordine di Nostro Signore Papa Benedetto XIV.*
- Bossut, C. (1778). *Nouvelles Recherches sur l'équilibre des voûtes en dôme*, *Memoires. Academie Royale des Sciences*, 587-596.
- Mascheroni, L. (1785). *Nuove ricerche sull'equilibrio delle volte*, Bergamo.
- Bergami, G. (1883). *Elementi di meccanica*, Napoli, (I ed. 1806).
- Bernoulli, J. (1744). *Curvatura veli*, Articolo XLVIII, Opera, Tomo I, pp.481-490, Ginevra.
- Bernoulli, J. (1744). *Explicationes, Annotationes et Additiones: de Velaria*, Articolo LXVI, Opera, Tomo I, pp. 652-658, Ginevra.
- Schwedler J.W., (1859). *Theorie der Stützlinie. Ein Beitrag zur Form und Stärke gewölbter Bögen*, “*Zeitschrift für Bauwesen*”, Bd. 9, 1859, coll. 109-126.
- Eddy, H.T. (1878). *Spherical Dome of Masonry*, Chapter XVI, *Researches in Graphical Statics*, pp. 56-59, Van Nostrand, New York.
- Lévy, M. (1888). *Cupoles en maçonnerie, Chapter II, La statique graphique esesapplications aux constructions*, IV Partie, pp.42-51, Gauthier -Villars Imprimeur - Librairie, Paris.
- Beltrami, E. (1882). *Sull'equilibrio delle superfici flessibili ed inestensibili*, Tomo III, Opera.
- Heyman, J., (1967). “On shell solution for masonry domes”, *International Journal of Solids and Structures*, 3, 227-241.
- Oppenheim, I.,J., Gunaratnam, D.,J., and Allen, R.,H., (1989). “Limit state analysis of masonry domes”, *ASCE Journal of Structural Engineering*, 115, 868-882.
- Tempesta, G., and Rapallini, M., (1997). “Henry T. Eddy's contribution to the calculus of masonry arches and domes”, *Proceedings of XXth International Congress of History of Science*, Liège.
- Paradiso M., and Tempesta, G., (2003). “Limit Analysis of Masonry Domes. A Numerical Method”, *XVI Congresso AIMETA di Meccanica Teorica e Applicata*, Ferrara.
- Paradiso, M., Pieroni, E., and Tempesta, G., (2006). “Masonry domes. topical nineteenth century graphical solutions and new approaches”, *Wondermasonry Workshop on Design for Rehabilitation of Masonry Structures*, Modellazione e Progetto di Interventi sul Costruito in Muratura, Firenze.

