

MULTIPOLARISATION RADAR RECEIVER FOR TARGET DETECTION

D. Giuli, L. Facheris, L. Baldini, M. Gherardelli

University of Florence, Italy

INTRODUCTION

The exploitation of polarisation state information for enhancing target detection performance in radar systems has recently become a recurring subject of interest (1), (2), (3). Performance improvements are due to the possibility of complementing the Doppler and spatial domain processing, with the polarisation domain signal processing: the potential of this integrated elaboration is mainly connected with the fact that the overall energy contained in the electromagnetic wave field backscattered by targets can be collected by a dual polarisation receiving system, since it is equipped with two orthogonally polarised channels and no loss of information occurs.

Optimum dual polarisation radar receivers can be derived through a statistical theory approach (4) developed for the detection of targets in the clear, that is when disturbance is supposed a white unpolarised background noise only. According to the mentioned approach, the optimum receiver schemes maximize the probability of detection P_D for given values of the probability of false alarm P_{FA} and for selected statistical characteristics of the received signals.

In the single hit detection case, the observation period of the received waveform is limited to the radar pulse duration; therefore the polarisation vector (including absolute phase and amplitude terms), although random, is constant throughout the observation period. The expression of the sufficient statistics and, consequently, the structure of the receiver that implements it are greatly simplified.

In the pulse train detection case, a decision test is performed after an observation period equal to the dwell time of the antenna on the target: the signal polarisation can be no longer considered constant, and a partially polarised target return must be considered.

When a single hit detection problem is considered, the front part of the dual polarisation receiver is composed of two identical filters matched to the transmitted waveform (time domain matching), while the second part of the receiver applies a linear transformation in the polarisation domain (polarisation matching) (4). The hypothesis of completely polarised echo allows further simplification in the receiver structure. This means that an optimum polarisation selection is simply synthesized after time-domain matched filtering. The main problem now is to determine the matrix elements of the polarisation

transformation to be used, which obviously depend on the received signal polarisation. Because the target echo polarisation state is generally a-priori unknown, the above matrix elements have possibly to be determined by means of an adaptive estimation process, which can easily be implemented only if target behavior is stationary or slowly variable in time.

In this paper we still consider the single hit detection problem, while assuming that the target echo polarisation is constant during pulse observation time, but unknown due to its randomness. A particular target detection technique is proposed and analysed in order to mitigate the effect of target polarisation randomness. Such a technique is based on a bank of linear polarisation filters providing maximum signal response for different and pre-set polarisations. The number of these filters and the location of their optimum polarisation in the polarisation space is to be chosen according to the expected statistical distribution of the received signal polarisation. To some extent, this technique applies a concept similar to that exploited in receivers using a bank of Doppler filters.

The performance of such a multipolarisation receiver is evaluated in terms of false alarm probability and target detection probability. Such evaluation is performed for a target in a Gaussian white zero-mean background noise and with six polarisation filters having their optimum polarisations symmetrically located on the Poincaré sphere.

PROPOSED SCHEME FOR TARGET DETECTION

The receiver scheme that we propose for detection of targets in presence of background noise is represented in Fig. 1, where R_H and R_V represent the dual polarisation signal samples after demodulation, filtering and sampling of the two orthogonally polarised signals. Such a scheme is based on a bank of polarisation filters performing a simple linear combination through complex valued weights α_n and β_n , of the same two complex valued signals received by the two orthogonally polarised channels. The optimum polarisation of the n -th filter is determined by α_n and β_n .

A bank of polarisation filters is implemented with different optimum polarisations. The latter are symmetrically displaced on the Poincaré sphere as shown in Fig. 2. The amplitude of each polarisation filter output is then squared and compared with a threshold set equal at each filter output. The target detection is based on a simple "or" logic

applied to all thresholding outcomes.

Our analysis, aims at evaluating the performance of this multipolarisation receiver, by finding the expression of false alarm probability and target detection probability, respectively.

False alarm probability evaluation

The purpose of the following analysis is to obtain the expression of the probability of false alarm as a function of the noise power and of the threshold used in the bank of filters. We suppose that the complex received dual polarisation noise signals R_H and R_V are statistically independent, zero-mean Gaussian distributed complex valued white random samples. The real and imaginary components of each signal sample are assumed as statistically independent of each other and having the same variance σ^2 . Under these conditions, when the first two polarisation filters outputs $v_1(t)$ and $v_2(t)$ are expressed as:

$$v_1 = \rho_1 e^{j\Phi_1} \quad (1a)$$

$$v_2 = \rho_2 e^{j\Phi_2}$$

and it is also assumed, with no loss of generality, that:

$$\alpha_1 = 1, \beta_1 = 0 \quad (1b)$$

$$\alpha_2 = 0, \beta_2 = 1$$

it results that ρ_1 and ρ_2 are distributed according to Rayleigh, with Φ_1, Φ_2 uniformly distributed in the interval $[0, 2\pi]$ while $\rho_1, \rho_2, \Phi_1, \Phi_2$ being independent random variables Papoulis (5).

This implies that the squared outputs of the first two polarisation filters γ_1 and γ_2 are independent and both have the same exponential distribution, while the power outputs of the other filters depend on γ_1, γ_2 and the relative phase $\xi = \Phi_2 - \Phi_1$. In fact, assuming that K is the number of filters in the bank, it is easily verified that for any integer n from 3 to K the power output of the filter can be expressed through the following relationship:

$$\gamma_n = f_n(\gamma_1, \gamma_2, \xi) \quad (2)$$

with

$$f_n(x, y, z) = |\alpha_n|^2 x + |\beta_n|^2 y + 2\sqrt{xy} |\alpha_n \beta_n| \cos(z - \Psi_n) \quad (3)$$

where:

$$\Psi_n = \begin{cases} \operatorname{tg}^{-1} \frac{\operatorname{Im}\{\alpha_n \beta_n^*\}}{\operatorname{Re}\{\alpha_n \beta_n^*\}} & \text{if } \operatorname{Re}\{\alpha_n \beta_n^*\} > 0 \\ \operatorname{tg}^{-1} \frac{\operatorname{Im}\{\alpha_n \beta_n^*\}}{\operatorname{Re}\{\alpha_n \beta_n^*\}} + \pi & \text{if } \operatorname{Re}\{\alpha_n \beta_n^*\} < 0 \end{cases}$$

where the symbol * denotes complex conjugation. It can also be proved that γ_1, γ_2 and ξ are independent random variables and that ξ is still uniformly distributed in $[0, 2\pi]$.

The false alarm probability P_{FA} is the

probability that at least one of the power outputs exceeds the threshold T ; therefore

$$P_{FA} = 1 - P_N \quad (4)$$

where:

$$P_N = \int_0^T d\gamma_1 \cdots \int_0^T p(\gamma_1, \dots, \gamma_k) \cdots d\gamma_k \quad (5)$$

Noting that $p(\gamma_n | \gamma_1, \gamma_2, \xi) = \delta[\gamma_n - f_n(\gamma_1, \gamma_2, \xi)]$, where δ is the Dirac operator, we obtain:

$$P_N = \int_0^{2\pi} d\xi \int_0^T d\gamma_1 \int_0^T p(\gamma_1, \gamma_2, \xi) S(\gamma_1, \gamma_2, \xi) d\gamma_2 \quad (6)$$

where

$$p(\gamma_1, \gamma_2, \xi) = \frac{1}{8\pi\sigma^4} \exp[-(\gamma_1 + \gamma_2)/2\sigma^2]$$

and

$$S(\gamma_1, \gamma_2, \xi) = \prod_{n=3}^K S_n(\gamma_1, \gamma_2, \xi)$$

with

$$S_n(\gamma_1, \gamma_2, \xi) = \begin{cases} 1 & \text{if } f_n(\gamma_1, \gamma_2, \xi) < T \\ 0 & \text{elsewhere} \end{cases}$$

Introducing the normalized random variables $z_1 = \gamma_1/\sigma^2$ and $z_2 = \gamma_2/\sigma^2$, and defining $H = T/\sigma^2$, we obtain:

$$P_N = \int_0^{2\pi} d\xi \int_0^H dz_1 \int_0^H p(z_1, z_2, \xi) S_N(z_1, z_2, \xi) dz_2 \quad (7)$$

where

$$p(z_1, z_2, \xi) = \frac{1}{8\pi} \exp[-(z_1 + z_2)/2] \quad (8)$$

and

$$S_N(z_1, z_2, \xi) = \prod_{n=3}^K S_{Nn}(z_1, z_2, \xi)$$

with

$$S_{Nn}(z_1, z_2, \xi) = \begin{cases} 1 & \text{if } f_n(z_1, z_2, \xi) < H \\ 0 & \text{elsewhere} \end{cases}$$

Where $f_n(z_1, z_2, \xi)$ is defined in (3). The independence of z_1, z_2, ξ allows to further simplify the expression of P_N . In fact, the step-valued function $S_N(z_1, z_2, \xi)$ can be used to define the integration limits of z_2 when z_1 and ξ are given, thus leading, after some manipulations, to the following final expression for P_{FA} :

$$P_{FA} = \exp(-H/2) + \frac{1}{4\pi} \int_0^{2\pi} d\xi \int_0^H \exp[-z_{\beta_{\min}}(z_1, \xi)/2] \cdot \exp(-z_1/2) dz_1 \quad (9)$$

where

$$z_{\beta \min}(z_1, \xi) = \min_{n=3, K} \{z_{\beta}^{(n)}(z_1, \xi)\}$$

with

$$z_{\beta}^{(n)}(z_1, \xi) = \min \left\{ H, \frac{1}{|\beta_n|^2} \left[|\alpha_n| \sqrt{z_1} \cos(\xi - \psi_n) + \sqrt{|\alpha_n|^2 z_1 [\cos^2(\xi - \psi_n) - 1] + H} \right]^2 \right\}$$

Probability detection evaluation

Let us suppose that the above considered additive noise corrupts a signal of known intensity and polarisation on reception. Therefore, the received dual polarisation samples are now given by:

$$\begin{aligned} R_H &= S_H + N_H \\ R_V &= S_V + N_V \end{aligned} \quad (10)$$

where N_H and N_V are the noise samples with the same statistics as before, while the target signal samples are now given by:

$$\begin{aligned} S_H &= \alpha A \exp(j\Phi_{1c}) \\ S_V &= \beta A \exp(j\Phi_{2c}) = \beta A \exp[j(\Phi_{1c} + \phi_r)] \end{aligned} \quad (11)$$

with

$$\alpha^2 + \beta^2 = 1$$

Where the total target signal power is $E = A^2$, and the real valued parameter α (or β) and ϕ_r represent the received target echo polarisation. The detection probability P_D can be expressed as:

$$P_D = 1 - P_{MD} \quad (12)$$

where P_{MD} is given by the same expression (7) giving P_N in the previous case, but with the following different expression for the joint probability distribution:

$$p(z_1, z_2, \xi) = \frac{1}{8\pi} \exp\left[-\frac{E}{2\sigma^2}\right] \exp\left[-(z_1 + z_2)/2\right] I_0[N(z_1, z_2, \xi)] \quad (13)$$

where

$$N(z_1, z_2, \xi) = \sqrt{\frac{E}{\sigma^2}} \cdot \sqrt{\alpha^2 z_1 + \beta^2 z_2 + 2\alpha\beta\sqrt{z_1 z_2} \cos(\xi - \phi_r)}$$

and

$$S_N(z_1, z_2, \xi) = \prod_{n=3}^K S_{Nn}(z_1, z_2, \xi)$$

with

$$S_{Nn}(z_1, z_2, \xi) = \begin{cases} 1 & \text{if } I_n(z_1, z_2, \xi) < H \\ 0 & \text{elsewhere} \end{cases}$$

while $I_0(x)$ being the modified Bessel function of the first kind of order zero. The quantity E/σ^2 is defined as the signal to noise ratio S/N .

Notice that in (13) the value of $S_N(z_1, z_2, \xi)$, given the normalized threshold T/σ^2 , depends exclusively on the polarisation parameters of the filters with n from 3 to K , while $p(z_1, z_2, \xi)$ is

determined only by the signal to noise ratio and by the polarisation of the received waveform.

RESULTS AND CONCLUSIONS

The above analysis applies to any number of polarisation filter. Some numerical results are shown referring to the case of six polarisation filters having their optimum polarisation symmetrically located over the Poincaré sphere (Fig. 2). The values of P_{FA} as a function of the normalized threshold T/σ^2 and the values of P_D as a function of T/σ^2 , of the signal to noise ratio S/N and of the target polarisation parameters (α, ϕ_r) have been numerically computed through (4) and (12).

In Fig. 3, which refers to the case $P_{FA} = 10^{-9}$ and $S/N(\text{dB}) = 16$, P_D is plotted as a function of the target polarisation along the Poincaré sphere semicircle shown in Fig. 2. The values of P_D are shown for the case of six polarisation filters (continuous line) and two polarisation filters only (dashed line; optimum polarisations: H and V).

In the same above conditions, the behavior of P_D is shown in Fig. 4 as a function of the signal to noise ratio S/N for a set polarisation represented by the point P shown in Fig. 2 (ellipticity angle: 22.5° , orientation angle: 22.5°).

Above results, even limited, show how the proposed multipolarisation receiver, while outperforming with respect to a single dual polarisation receiver (but also with respect to a single polarisation receiver), can improve target detection while providing less sensitivity to target polarisation randomness.

REFERENCES

1. Giuli, D., 1986, *Proc. IEEE*, 74, 245-269.
2. Poelman, A.J., 1975, *IEEE Trans. on AES*, 11, 660-663.
3. Poelman, A.J., 1977, "Reconsideration of the target detection criterion based on adaptive antenna polarisations", AGARD Conf. on New Devices, Techniques and Systems in Radar, Conf. Rept. 197, Paper n. 30.
4. Giuli, D., and Rossettini, A., 1987, "Analysis of radar receivers for Dual Polarisation Target Detection", IEE Int Conf. RADAR 87, London (U.K.)
5. Papoulis, A., 1984, "Probability, random variables, and stochastic processes", Mac Graw Hill Book Company (USA).

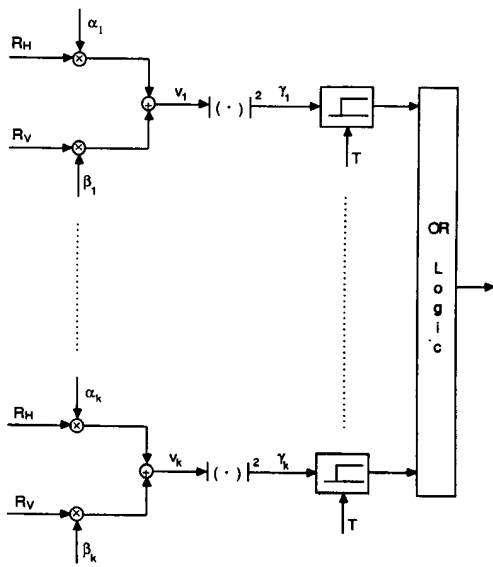

Figure 1 Multipolarisation receiver scheme (after demodulation)

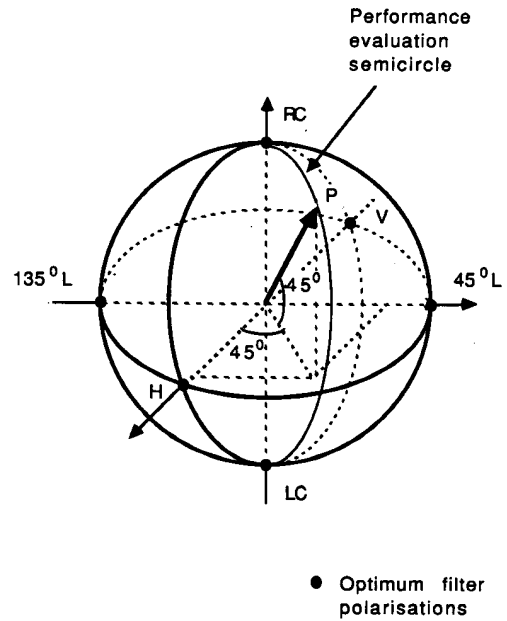

Figure 2 The Poincaré sphere

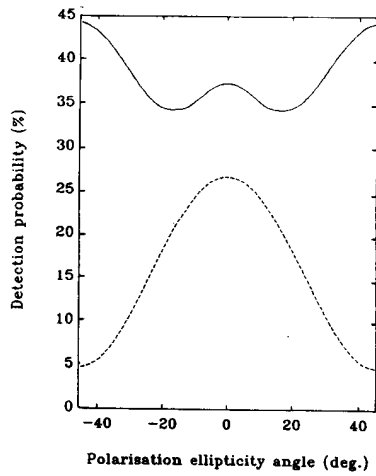

Figure 3 Target detection probability versus target polarisation (ellipse orientation angle: 22.5° ; ellipticity angle $\in [-45^\circ, 45^\circ]$), for $S/N=16$ dB and $P_{FA}=10^{-9}$. Continuous line: six polarisation filters; dashed line: two polarisation filters

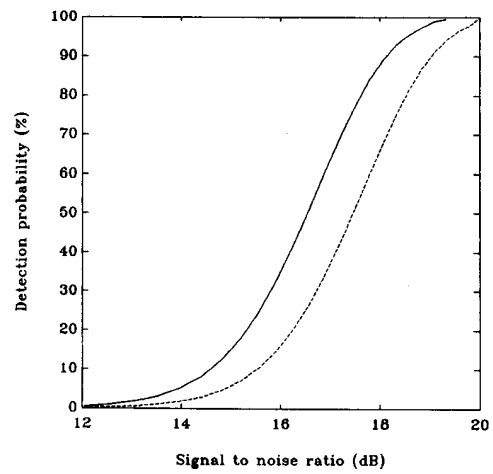

Figure 4 Target detection probability versus signal to noise ratio for $P_{FA}=10^{-9}$ and set polarisation (ellipse orientation angle: 22.5° ; ellipticity angle: 22.5°). Continuous line: six polarisation filters; dashed line: two polarisation filters