



UNIVERSITÀ  
DEGLI STUDI  
FIRENZE

# FLORE

## Repository istituzionale dell'Università degli Studi di Firenze

### **RotoSAR for Monitoring Bridges**

Questa è la Versione finale referata (Post print/Accepted manuscript) della seguente pubblicazione:

*Original Citation:*

RotoSAR for Monitoring Bridges / Pieraccini, Massimiliano; Miccinesi, Lapo. - ELETTRONICO. - (2018), pp. 0-0. (Intervento presentato al convegno 14th European Radar Conference 2017 EuRAD tenutosi a Nuremberg, Germany, Germany nel 11-13 Oct. 2017) [10.23919/EURAD.2017.8249209].

*Availability:*

This version is available at: 2158/1094656 since: 2018-05-11T10:43:28Z

*Publisher:*

Institute of Electrical and Electronics Engineers

*Published version:*

DOI: 10.23919/EURAD.2017.8249209

*Terms of use:*

Open Access

La pubblicazione è resa disponibile sotto le norme e i termini della licenza di deposito, secondo quanto stabilito dalla Policy per l'accesso aperto dell'Università degli Studi di Firenze (<https://www.sba.unifi.it/upload/policy-oa-2016-1.pdf>)

*Publisher copyright claim:*

(Article begins on next page)

# RotoSAR for Monitoring Bridges

Massimiliano Pieraccini, and Lapo Miccinesi

Department of Information Engineering  
 University of Florence  
 Via Santa Marta, 3 50139 Firenze, Italy  
[massimiliano.pieraccini@unifi.it](mailto:massimiliano.pieraccini@unifi.it)

**Abstract**— RotoSAR is a ground-based SAR (Synthetic Aperture Radar) able to detect the three displacement components of large structures like bridge, towers, dams, and buildings. In this paper the RotoSAR theory has been applied to a specific case of engineering interest: the static testing of bridges. An in-field test of the technique and the prototype has been performed during the static test of a bridge in Florence (Italy).

**Keywords**— GB-SAR; Radar; remote sensing; SAR

## I. INTRODUCTION

Ground-Based Interferometric SAR (Synthetic Aperture Radar) systems are popular remote sensing instruments to detect small displacements of large structures like bridges [1]-[4], towers [5]-[6], dams [7],[8], buildings [9]. These radars are able to provide displacement maps of the structure under test, but have a critical limitation: they detect only the displacement component along the range direction. But the movement of an architectonic structure can be rather complex, and it is not always possible to make *a-priori* assumptions on the displacement direction as demonstrated, as an example, in [4]. For this reason in the engineering practice it is of great interest an interferometric radar able to provide the whole displacement vector. With this aim in previous works [10]-[13] one of the authors of this paper proposed a SAR system (RotoSAR) based on a radar head fixed at a rotating arm with the antennas aimed in direction orthogonal to the rotation plane. This system is able to provide both SAR images and the displacement vector.

In this paper the RotoSAR is used for the static testing of bridges. The radar technique is discussed with reference to the specific application. Finally, an experimental in-field test during the static test of a bridge is presented.

## II. THE ROTOSAR PROTOTYPE

The prototype we used is shown in Fig. 1 [10]- [13]. A couple of antennas have been fixed on a rotating arm controlled by a step motor. The distance between center of rotation and median point of the centers of phase of antennas is  $r_0 = 0.88$  m. A vector network analyzer (VNA) HP8720D operates as transceiver providing a continuous wave stepped frequency signal (CWSF) in X-band with central frequency  $f_c = 10$  GHz and bandwidth  $B = 160$  MHz. Two RF cables link the VNA to the front-end fixed at the rotating arm. The antennas are two horns.

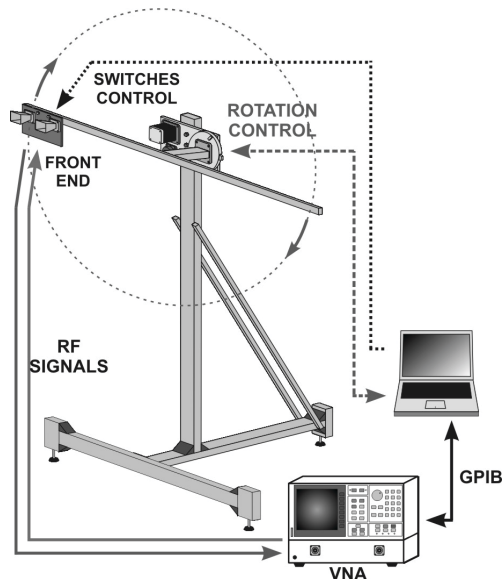

Fig. 1. RotoSAR prototype

With reference to Fig. 2, the VNA output power is 0 dBm, the one-way cable loss is -5 dB, the TX amplifier gains 10 dB. Two single-pole double-throw (SPDT) switches provide a direct path (through a -40 dB attenuator) between the transmitter and the receiver in order to perform calibrated measurements. The aim of the calibration is to avoid that the movements of the cables could affect the phase of the measurement. The gain of the RX amplifier is 20dB.

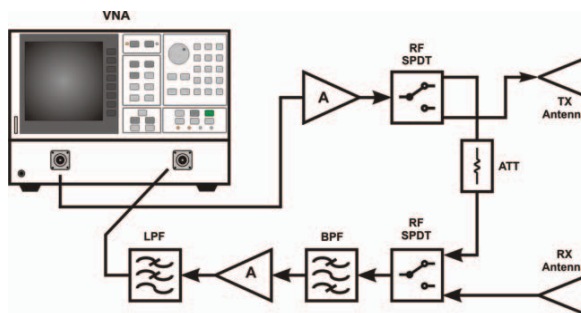

Fig. 2. Block scheme of radar

The prototype operates step-by-step both in frequency and in rotation. The number of frequencies  $N_f$  has been set for avoiding range ambiguity in radar image. The unambiguous range  $R_u$  is given by

$$R_u = \frac{c}{2B}(N_f - 1) \quad (1)$$

with  $c$  speed of light. Therefore setting  $N_f = 401$ , it results  $R_u = 375$  m, that is a reasonable value for the scenario where the prototype has been used. The acquired data are focused with the algorithm described in [14].

### III. ROTOSAR FOR DETECTING 2D-DISPLACEMENTS

A unique advantage of RotoSAR is its capability to detect more than a single component of the displacement. With reference to Fig. 3, we consider a target that can have both vertical and longitudinal displacements, but not a transversal displacement (as it is typical of most bridges under static test).

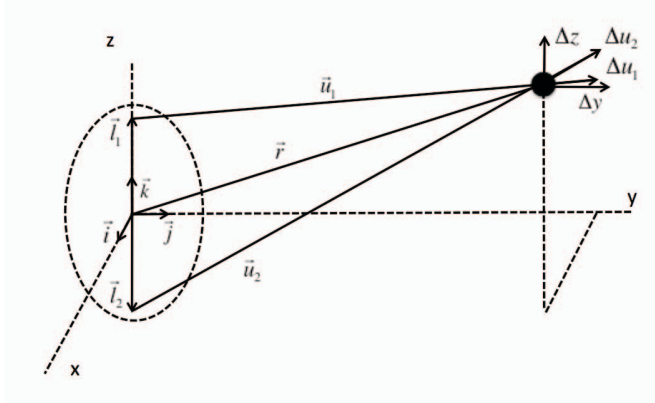

Fig. 3. Displacement components detection

Generally speaking, the detected differential phase ( $\Delta\phi$ ) and displacement ( $\Delta u$ ) are linked by the well-known relationship [1],[2]:

$$\Delta u = \frac{\lambda}{4\pi} \Delta\phi \quad (2)$$

The RotoSAR completes two full rotations (before and after a possible displacement of the target). By processing separately the upper and lower half-circle, we obtain four images. From the interferogram between the two images taken from the upper arc, we obtain the component ( $\Delta u_1$ ) of the displacement along the direction between the target and the upper phase center. From the interferogram between the two images taken from the lower arc, we obtain the component ( $\Delta u_2$ ) of the displacement along the direction between the target and the lower phase center. Both the phase centers are in the  $z$ -axis.

By supposing that displacement has only the vertical ( $\Delta z$ ) and the longitudinal ( $\Delta y$ ) components, with reference to Fig. 3 we can write

$$\begin{pmatrix} \Delta u_1 \\ \Delta u_2 \end{pmatrix} = M \begin{pmatrix} \Delta y \\ \Delta z \end{pmatrix} \quad (3)$$

with

$$M = \begin{bmatrix} \cos \vartheta_y^{(1)} & \cos \vartheta_z^{(1)} \\ \cos \vartheta_y^{(2)} & \cos \vartheta_z^{(2)} \end{bmatrix} \quad (4)$$

$$\cos \vartheta_y^{(m)} = \frac{\vec{u}_m \cdot \vec{j}}{|\vec{u}_m|} \quad m=1,2 \quad \cos \vartheta_z^{(m)} = \frac{\vec{u}_m \cdot \vec{k}}{|\vec{u}_m|} \quad m=1,2 \quad (5)$$

Therefore

$$\begin{pmatrix} \Delta y \\ \Delta z \end{pmatrix} = M^{-1} \begin{pmatrix} \Delta u_1 \\ \Delta u_2 \end{pmatrix} \quad (6)$$

The later equation allows to calculate the longitudinal and vertical displacement from the measured displacements  $\Delta u_1$  and  $\Delta u_2$ .

### IV. SIMULATION OF THE APPLICATION OF ROTOSAR FOR BRIDGE MONITORING

In order to test the method in a realistic scenario, we have taken in consideration a model of bridge as in Fig. 4.

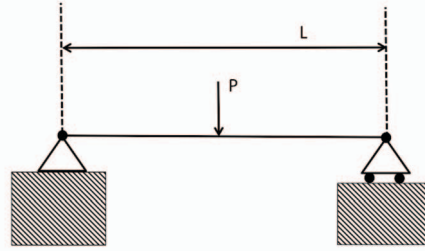

Fig. 4. Bridge modeling

The structural data we used are in Table I.

TABLE I. SIMULATION PARAMETERS

Structural data	units	value
Length (L)	m	35
Elastic modulus	t/m <sup>2</sup>	3000000
Inertial momentum	m <sup>4</sup>	1
Applied load (P)	ton	42
Position of the load (P)	m	17,5

Generally speaking the points in the neutral axis of the bridge exhibit only vertical displacements, but in a practical implementation of the method the measurement points are in the lower deck, i.e. at a distance not null from the neutral axis. In the simulation we suppose that measurements points are 1 m under the neutral axis of the bridge. The obtained simulated displacements in vertical and horizontal directions are plotted in Fig. 5.

With reference to Fig. 6, we have supposed the RotoSAR is positioned close to a pillar (4 m below the deck) and it is rotated back of 20° for a better view of the bridge deck. The deck has been simulated with 21 equal point scatters.

The radius of RotoSAR was 1 m and the interferogram has been calculated only in the pixel where the power amplitude was larger then 50% of the maximum. By using the method

described in the previous section we obtained the plots in Fig. 7 and 8, that demonstrate RotoSAR is able to detect correctly both the components of the displacement.

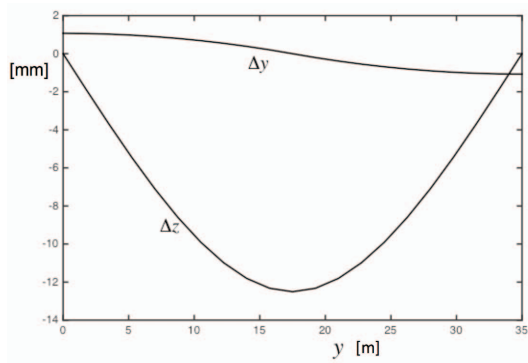

Fig. 5. Displacement of the lower deck of the modeled bridge

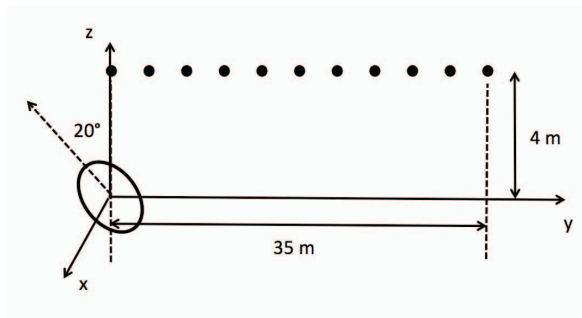

Fig. 6. Measurement geometry

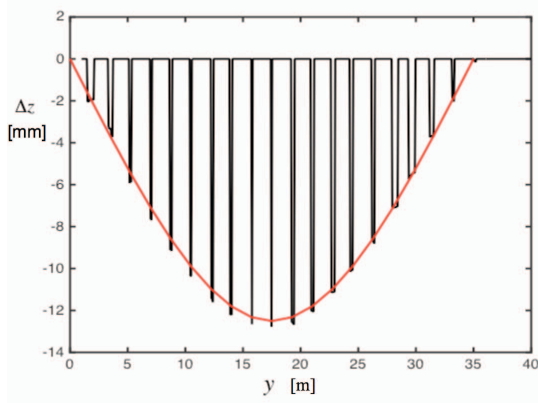

Fig. 7. Vertical displacement detected by RotoSAR. In red the true values.

The aim of this simulation has been even to assess how much the longitudinal movement of the lower deck of a bridge can affect the radar measurement of the vertical displacement. In previous works [1]-[4] the vertical displacement has been derived by the range displacement by supposing negligible the longitudinal displacement. In effect, this assumption is true only if the measurement points are in the neutral axis of the bridge, but this is not always true. In particular, for the case we considered in this simulation (based on realistic hypotheses

about the structural behavior of the bridge), if we suppose the longitudinal displacement negligible, we obtain the plot in Fig. 9, where is evident that displacements of the farthest points are heavily overestimated

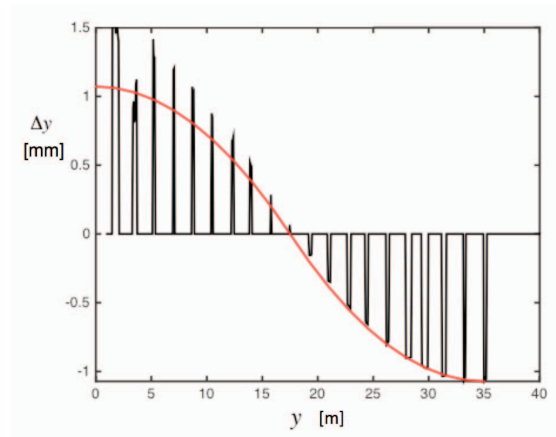

Fig. 8. Longitudinal displacement detected by RotoSAR. In red the true values.

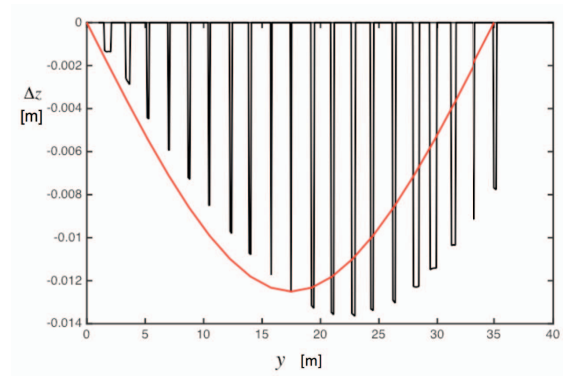

Fig. 9. Vertical displacement detected by RotoSAR neglecting the longitudinal displacement.

Indeed, although the longitudinal displacement is small in comparison with the vertical displacement, when the radar operates at grazing angles its component in range is large and can affect heavily the measurement result.

#### V. A PRELIMINARY IN-FIELD TEST OF ROTOSAR

On the occasion of the static test of the “Statuto” bridge in Florence (Italy), the RotoSAR has been allowed to operate in-field for the first time. A set of four telescopic deflection measuring systems has been installed under the deck. They used displacement transducers with 50 mm travel and accuracy 0.01 mm, linked to a digital acquisition unit through 10 m cables. In order to identify a high signal point-target in the radar image a Corner Reflector (CR) has been positioned on the deck very close to the point of contact of one of the telescopic transducer. Fig. 10 and Fig. 11 show a draw and a picture of the in-field installation.

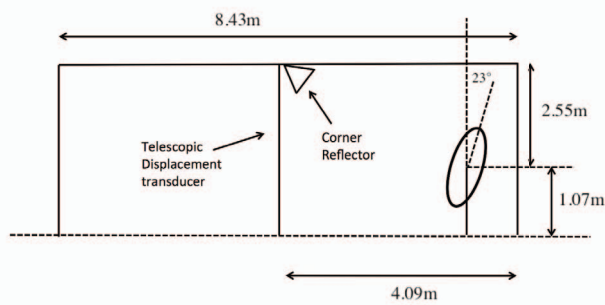

Fig. 10. Draw of the experimental set-up.

A unique advantage of RotoSAR is its capability to detect more than a single component of the displacement. With reference to Fig. 3, we consider a target that can have both vertical and longitudinal displacements, but not a transversal displacement (as it is typical of most bridges under static test).

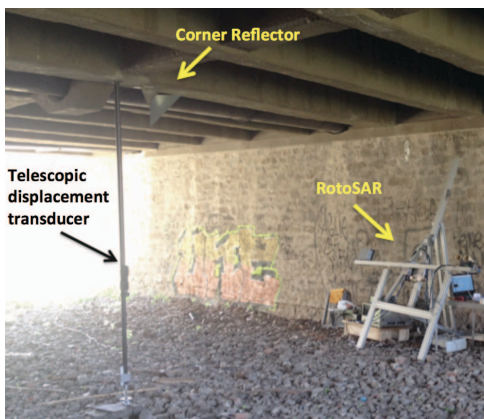

Fig. 11. Picture of the in-field installation.

Two radar measurements (i.e. two complete rotations of the arm) have been performed: the first when the bridge was unloaded and the second with a load of 4 trucks parked side by side, 44 ton each. The obtained radar image, focused on the plane at 2.55 m above the center of RotoSAR, is shown in Fig. 12.

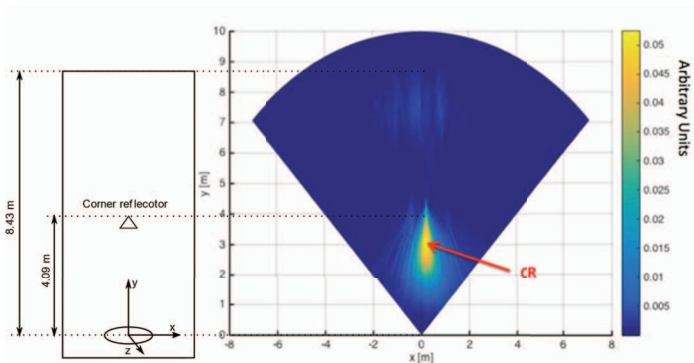

Fig. 12. Radar image of the lower deck.

A power threshold equal to 55% of the maximum has been applied for obtaining the vertical displacement and the

longitudinal displacement:  $\Delta z = -1.25$  mm and  $\Delta y = 0.525$  mm. The vertical displacement can be confronted with the value obtained with the telescopic transducer that has given  $\Delta z = -1.01$  mm.

## VI. CONCLUSION

Theory and practice of RotoSAR for monitoring large structures has been discussed in detail. The prototype has been experimental tested in-field during the static testing of a bridge. The vertical displacement measured by the radar has been in agreement with the value obtained with a telescopic deflection transducer. Better accuracy (comparable with the standard geotechnical equipment) could be obtained using higher frequency. As an example, using 77 GHz instead of 10 GHz could improve the accuracy of a factor 7.7.

## REFERENCES

- [1] M. Pieraccini, D. Tarchi, H. Rudolf, D. Leva, G. Luzi, G. Bartoli, C. Atzeni, "Structural static testing by interferometric synthetic radar". *NDT & E International*, Vol. 33, No. 8, pp. 565-570, 2000
- [2] D. Dei, M. Pieraccini, M. Fratini, C. Atzeni, G. Bartoli, "Detection of vertical bending and torsional movements of a bridge using a coherent radar", *NDT&E International* Vol. 42, pp. 741-747, 2009
- [3] Z. Qiu, J. Yue, X. Wang, S. Yue, "Deformation monitoring of bridge structures by ground-based SAR interferometry", *Communications in Computer and Information Science*, Vol. 569, pp. 872-881, 2016
- [4] D. Dei, D. Mecatti, and M. Pieraccini, "Static Testing of a Bridge Using an Interferometric Radar: The Case Study of "Ponte degli Alpini," Belluno, Italy", *The Scientific World Journal*, Vol. 2013, Article ID 504958, 2013
- [5] C. Atzeni, A. Bicci, D. Dei, M. Fratini, M. Pieraccini, "Remote survey of the leaning tower of Pisa by interferometric sensing", *IEEE Geoscience and Remote Sensing Letters*, Vol. 7, No. 1, pp. 185-189, 2010
- [6] G. Luzi, M. Crosetto, M. Cuevas-González, "A radar-based monitoring of the Collserola tower (Barcelona)." *Mechanical Systems and Signal Processing*, Vol. 49, No. 1-2, pp. 234-248, 2014
- [7] Q. Huang, J. Yue, J. Gong, "Monitoring of Geheyan Dam deformation using GBInSAR technology", *Advances in Science and Technology of Water Resources*, Vol. 36, No. 3, pp. 47-51, 2016
- [8] W. Jenkins, B. Rosenblad, F. Gomez, J. Legarsky, and E. Loehr, "Deformation measurements of earth dams using a ground based interferometric radar," in: Proceedings of the 2012 ASDSO Annual Conference on Dam Safety, p. 15, (GBIR) Association of State Dam Safety Officials-Dam Safety, Denver, Colo, United States, September 2012.
- [9] M. Pieraccini, G. Luzi, D. Mecatti, M. Fratini, L. Noferini, L. Carissimi, G. Franchioni, C. Atzeni, "Remote sensing of building structural displacements using a microwave interferometer with imaging capability", *NDT&E International* Vol. 37, pp. 545-550, 2004
- [10] M. Pieraccini, F. Papi, and S. Rocchio. "Interferometric RotoSAR." *Electronics Letters* Vol. 51 No.18 pp. 1451-1453, 2015
- [11] M. Pieraccini, N. Agostini, F. Papi, S. Rocchio, "A rotating antenna ground-based SAR" in IEEE 2015 European Microwave Conference (EuMC), pp. 1515-1518, 2015
- [12] M. Pieraccini, F. Papi, S. Rocchio "SAR imagery by RotoSAR" in: 2015 IEEE International Conference on Microwaves, Communications, Antennas and Electronic Systems (COMCAS), pp. 1-5, 2015
- [13] M. Pieraccini, "Polarimetric RotoSAR", in: 2016 IEEE Radar Conference (RadarConf), 2-6 May 2016, Philadelphia, PA, pp. 1-5, 2016
- [14] M. Pieraccini, L. Miccinesi. "ArcSAR: Theory, Simulations, and Experimental Verification." *IEEE Transactions on Microwave Theory and Techniques* (2017), Vol. 65, No. 1, pp. 293-301, January 2017