

# Quiet and light spoked wheel centres made of Austempered Ductile Iron

Andrea BRACCIALI<sup>1</sup>, Stefano MASAGGIA<sup>2</sup>, Gianluca MEGNA<sup>1</sup>, Enrico VENERI<sup>2</sup>

<sup>1</sup>Department of Industrial Engineering, Università di Firenze, Florence, Italy

<sup>2</sup>Zanardi Fonderie S.p.A., Minerbe, Verona, Italy

[gianluca.megna@unifi.it](mailto:gianluca.megna@unifi.it)

## Abstract:

Monobloc wheels are today the main choice of all manufacturers and system operators (trains and metros) thanks to their low weight, simple maintenance and easy approval processes. However, tyred wheels could be competitive again in some situations if a proper redesign is performed, considering that nowadays disk braking is used in almost all vehicles. Both wheel centres and tyres can be manufactured differently in order to eliminate the critical features of their old fashioned design. Materials and shapes can be managed to optimize both mass and maintenance. In this paper, the design process of new wheel centres made of Austempered Ductile Iron (ADI) for a Diesel Multiple Unit (DMU) is described, with particular reference to casting simulations, static and fatigue structural assessment. Mechanical properties of ADI are also introduced and compared to those of steels normally used for railway wheels.

**Keywords:** tyred wheel; wheel centre; austempered ductile iron; lightweight design; low noise wheel

## 1. INTRODUCTION

The use of unconventional or innovative materials for wheelsets is strongly limited in Europe by the current standardization frame. EU Directives and Regulations on safety and interoperability on railways of the Union allow only the use of materials described in the EN standards “supporting” them. Steel grades for rails and wheels are prescribed as these elements are the interface between two subsystems (infrastructure and rolling stock) and their compatibility must be ensured across Europe. On the opposite, standards that define the performances and not the materials are, for example, those about bogie frames and carbodies, in which acceptance tests are defined but the designer has the freedom to choose the architecture and the materials according to the needs.

In this research, a new material for tyred wheel centres is evaluated. As long as wheels centres are not considered in the current EU regulation frame, different materials could be used.

Multi-material tyred wheels have been proposed in the past in order to achieve a lower noise emission [1] and lower mass [2]. However, in both cases, aluminium wheel centres were used and to the author’s knowledge no prototypes were tested in service.

An innovative tyred wheel with spoked wheel centre casted with Austempered Ductile Iron (ADI) is developed in this research to cope with both problems of unsprung mass and noise. ADI is a recently developed material, standardized according to [4] and [5], with mechanical properties similar to steels, while aluminium suffers from low Young’s modulus and an undefined fatigue endurance limit. ADI consists of a ductile iron subjected to an isothermal heat treatment called *austempering* whose peculiar properties make this material a serious competitor of alloyed high strength steels (e.g. 42CrMo4), with the advantages to be lighter than steel (7.25 kg/dm<sup>3</sup> instead of 7.85 kg/dm<sup>3</sup>) and easily castable with excellent castings quality [3]. Widespread NDT can be used similarly to steel to check sanity and integrity of castings.

## 2. THE NEW WHEEL CENTRE

During the redesign process of the tyred wheel for a metro vehicle, the replacement of the original corrugated forged wheel centre with a casted one was proposed. ADI castings were chosen to reduce mass and improve mechanical properties at the same time. However, the starting wheel centre was already optimized in terms of mass, as it is known that corrugated wheel webs are very stiff in lateral direction and therefore the thickness of the web is the lowest possible. This practice is very common, for example, in Japanese vehicles [8]. The final mass reduction was only 10 kg, but these preliminary checks proved that a solution with two inclined ranks of spokes was feasible.

The same philosophy was then applied to the redesign of the tyred wheel of the widespread ALn668 DMU. The 920 mm diameter original wheel mass is 385 kg, and the axisymmetric forged and laminated steel wheel centre contributes to it for 47%. In another paper [9], two of the authors performed the optimization of the tyre thickness showing that it can be reduced if there is no thermal input on the tread by braking, resulting in a large tyre mass reduction. In the present case the wheels are tread braked and therefore it was initially decided to maintain the same tyre thickness and the same tyre / wheel centre mating diameter.

The design of the new tyred wheel (Fig. 1) allows a mass reduction of 50 kg. Further interesting new features of this design concerns the methods by which the tyre is fitted on the wheel centre. However, these aspects are explained in the companion paper [10].

The structural design of the wheel centre allowed minimizing the amount of material used. As a result, the lateral external surface is about 50% of the original wheel centre. Therefore, it is expected that this wheel centre will be particularly quiet because of the limited surface and of the higher damping offered by cast iron compared to steel.

### 2.1. ADI mechanical properties

Material used for axisymmetric wheel centres usually exhibit a high ductility and a relatively low yield strength, resulting in possible permanent deformations after the tyre

fitting process, which induces high stresses and strains due to the high value of interference [11]. Wheel centres for ALn668 are still produced in Fe42 steel according to Italian standard UNI 7175:1973.

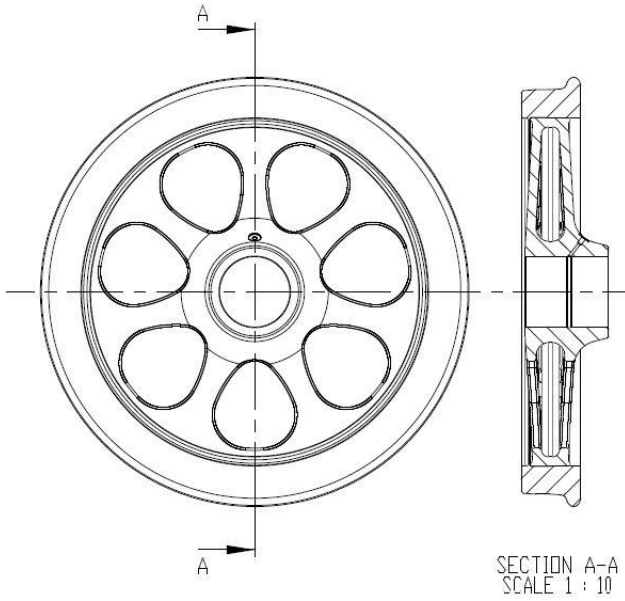

Fig. 1 New tired wheel with ADI casted wheel centre and steel tyre designed as replacement the ALn668 DMU original wheel.

The mechanical properties of ADI selected to replace the current steel are described according to [4]. With the austempering process a microstructure, named Ausferrite, is obtained. It consists of acicular ferrite and retained austenite, and offers outstanding properties in terms of strength and ductility, up to twice those of conventional spheroidal cast irons (Table I). It is worth highlighting that the plastic behaviour of very ductile materials is quite unpredictable when the yield stress is exceeded, while ADI shows a work hardening behaviour as shown in Fig. 2.

TABLE I. COMPARISON OF MECHANICAL PROPERTIES OF SPHEROIDAL, ADI CAST IRON AND STEELS FOR WHEEL CENTRES

Mechanical properties	JS/800-2 ISO 1083	JS/800-10 ISO 17804	Fe 42 UNI 7175-73
Young's modulus [GPa]	176	170	210
Poisson's ratio [-]	0.28	0.27	0.3
Minimum yield strength $R_{p0.2}$ [MPa]	480	500	235
Minimum tensile strength $R_m$ [MPa]	800	800	410
Minimum elongation at fracture $A_5$ [%]	2	10	22
Fatigue limit $S_e$ (50% probability of survival) [MPa]	304	375	-

A common criticism about cast iron properties is the reduced value of the absorbed energy during the Charpy impact test. Extensive testing performed at extremely high strain speed with the SHTB (Split Hopkinson Test Bar), as shown in [6] and [7], confirmed the return of experience of ADI components subjected to heavy shocks that survive

more than expected as failure strain increases with strain rate.

Impact strength is a useful parameter to compare different materials belonging to the same family (e.g. steel grades), but it does not provide any information to be used in dynamic Finite Element models with explicit solvers (such as LS-DYNA). ADI exhibits no necking during tensile tests, i.e. its behaviour is brittle at macroscopic scale, although fracture strain may be large. However, at microscopic level, fracture surface exhibits dimples formation, that is ductile behaviour. The use of ADI is extremely favourable, therefore, when loads are reasonably known such as in the railway case, in which also steels, that are ductile, normally fracture with a brittle behaviour due to fatigue.

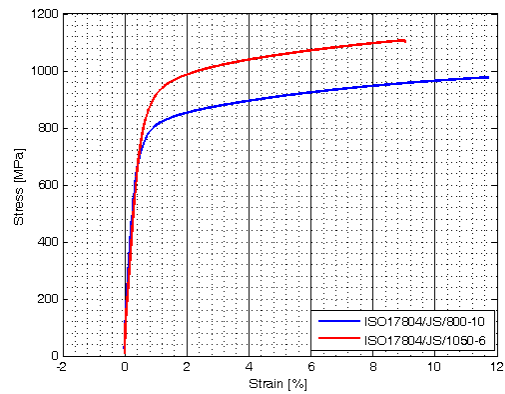

Fig. 2 Experimental strain – stress curves for two different grades of ADI from a tensile test (data supplied by Zanardi foundry).

### 3. DESIGN STEPS

#### 3.1. Casting simulation

One of the main advantages of a cast iron casting is the possibility to achieve almost any shape, even if relevant thickness changes are present.

However, in order to reach a good quality casting without internal porosity, the design of the mould is a very important step. Filling and cooling are therefore optimized by computer simulations in order to verify that shrinkage is localized outside the main casting areas. Additional chillers may be designed to drive solidification increasing the cooling rate of the thicker zones, and to avoid interferences between the various feeding points.

The results of the simulations applied to the new wheel centre have shown that the shape is castable and with a few adjustments a very good quality is achievable. Images of the final casted wheel centre will be shown in [12].

#### 3.2. Mechanical assessment

The methods to assess the mechanical behaviour of a tired wheel are not defined by current European standards. Old UIC codes (UIC 810-1, UIC 810-2, UIC 810-3, UIC 812-1, UIC 812-4, UIC 812-5 and UIC 813) only cover quality requirements, tyre fitting and tolerances.

Casted monobloc steel wheels are considered in two technical specifications (CEN/TS 13979-2:2011 and CEN/TS 15718:2011), without major differences from the main standards for forged and rolled monobloc wheels ([13], [14]).

Static and high-cycle fatigue validation are therefore discussed in this paper, starting from the load cases described in [13] for a wheel load of 58.86 kN, which are independent from the type of wheel (tyred or monobloc) (Table II). The main difference is the initial stress state of the wheel centre, induced by fitting of the tyre (whose thickness is 65 mm in new conditions and 35 mm in worn conditions). Differently from the original wheel centre, in the new design spokes are subjected only to compression after fitting of the tyre. These initial compression stresses are high due to the large interference value ( $\Delta D=0.94\div 1.145$  mm) and high thickness of a new tyre, with relevant influence on both static and fatigue assessment.

Finite Element Method (FEM) was used to perform calculations in both linear-elastic and elasto-plastic strain ranges, including frictional contacts at the mating surfaces. FE model validation is described in both static and fatigue conditions in [12].

TABLE II. LOAD CASES FOR THE MECHANICAL ASSESSMENT [13]

Load case	$F_z$ [N]	$F_{y2}$ [N]	$F_{y3}$ [N]
1) Straight track	73575	-	-
2) Curved track	73575	41202	-
3) Switch	73575	-	24741

### 3.2.1. Fitting assessment

The tyre fitting on the wheel centre and the axle fitting are simulated considering mean values of the tolerance range. Non-linear frictional contacts at the mating surfaces are modelled with a coefficient of friction of 0.3. An example of the stresses induced by this process is shown in Fig. 3. The equivalent Von Mises stress at each node is always lower than the yield limit. Fig. 4 shows the detail of a spoke, in which the vectors representing the principal stresses are plotted for each node and it is possible to see that the minimum principal stress (compression) is dominant over the other components.

#### 3.2.1. Static assessment

The external forces shown in Table II are superimposed to the initial stress state due to both tyre and hub fitting in different angular position. The equivalent Von Mises stress is compared to the yield stress of the material, identifying areas potentially subjected to plastic deformation. In this case, all stresses are lower than the yield limit with a safety factor  $> 1.13$ . The curved track load case is the most critical one due to the greater lateral forces towards the inner part of the wheel. However, the initial compression stress is not totally recovered on the external spoke of the wheel centre, as shown in Fig. 5.

#### 3.2.1. Fatigue assessment

Fatigue assessment is made by comparing the fatigue limit with the alternating stress resulting from the application of cyclic loads. Fatigue limit is usually derived by simple uniaxial and pure alternating tests (tension-compression or rotating bending with  $R = \sigma_{min} / \sigma_{max} = -1$ ). However, mechanical components are often subjected to complex stress distribution, i.e. multiaxial fatigue, which

can be reduced to an equivalent uniaxial stress. This may not be straightforward, depending on the geometry of the component and the stress field, justifying the existence of the many multiaxial fatigue methods available [15].

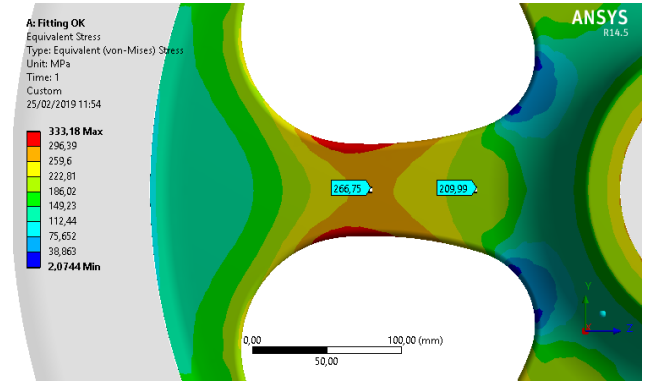

Fig. 3 Equivalent Von Mises stresses due to the tyre fitting process, to be compared with the yield limit of the material.

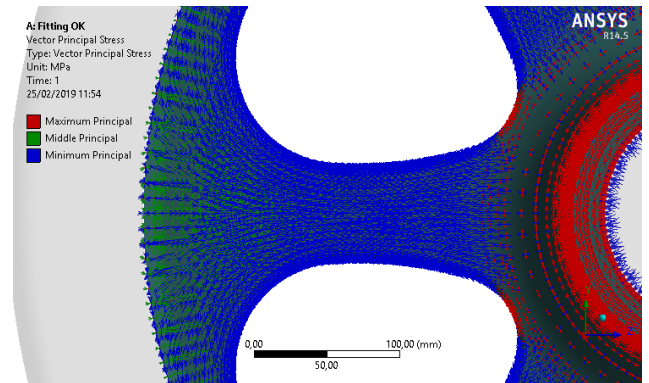

Fig. 4 Plot of the vector principal stress of each node. Except for the fitting zones, minimum principal stress is dominant on the other stress components.

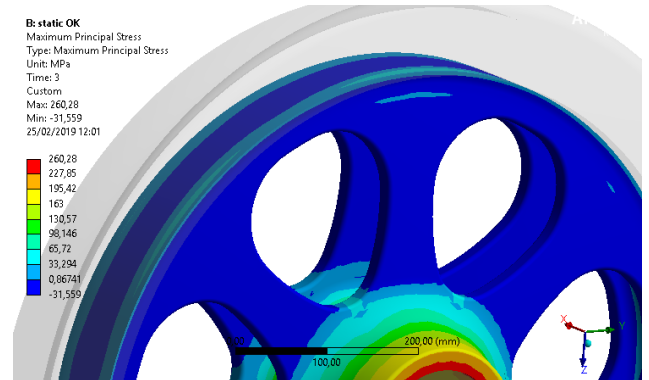

Fig. 5 Maximum principal stresses after the application of external loads derived from case 2. The initial compression state is not fully recovered.

Stress fields can be classified by means of the *biaxiality index a* (or *principal stress ratio*), defined as the ratio of the smaller principal stress and the larger principal stress for each node. If  $a = 0$  the stress is *uniaxial*, if  $a = 1$  the stress is *equibiaxial* and if  $a = -1$  the stress is *pure shear*. The plot of the biaxiality index for the wheel centre is shown in Fig. 6.

As the wheel centre is designed to work mainly in compression, most of the parts of the wheel centre have a biaxiality index near zero even if external loads are applied,



especially for the central part and base of the spokes, which are the most stressed areas.

The effect of mean stress on fatigue life of mechanical components is usually important for notched parts, where high stress concentrations may occur. These may be the reason why the assessment of monobloc wheels is usually done comparing the alternating stress with the alternating fatigue limit independently from the mean stress value. Even if this method could be questionable, it is used since many years and proved to be reliable for the steel grades ER7 or ER8 commonly used for monobloc wheels ( $R_{p0.2} = 355$  MPa,  $S_e = 180$  MPa for machined web and  $S_e = 145$  MPa for unmachined web). These fatigue limits are the result of a large number of pure alternating stress tests (force applied on the rim along the wheel axis) in which the specimen is the wheel itself.

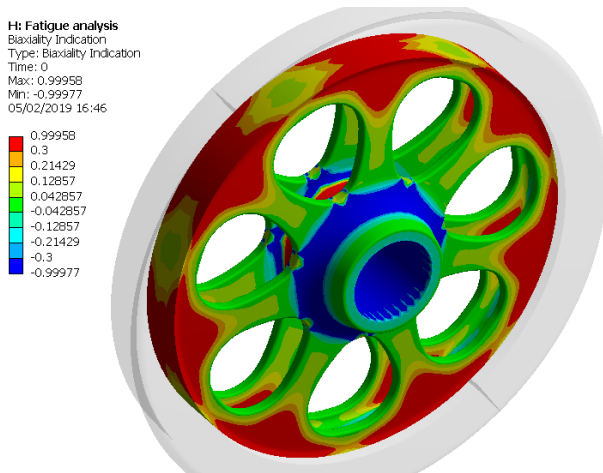

Fig. 6 Bixiality index for the ADI wheel centre with fitting loads and external loads (case 2). Values near zero corresponds to uniaxial stresses.

However, for green sand castings surface quality may be an issue if a machining or shot-peening are not applied after unmoulding. Except for the mating surfaces, the new ADI wheel centres are not machined and therefore proper coefficients must be applied to reduce the fatigue limit. According to Zanardi internal tests conducted at  $R = -1$ , these coefficients are  $K_{L1} = 0.625$  and  $K_{L2} = 0.357$  respectively for “small” and “large” surface defects according to visual inspection criteria defined in [16]. Although surface quality usually improves during the optimization of the manufacturing process,  $K_{L2}$  is usually applied at a design stage. Together with the reduction coefficient needed to consider a probability of survival of 99.7%, this leads to a very conservative fatigue limit of  $S_e = 83$  MPa.

Stress concentration due to bad surface quality does not affect the fatigue life in the same way for tensile mean stress or compressive mean stress [17]. In fact, cracks in a notched component subjected to compressive mean stress cannot grow further until an external load introduces either a tensile stresses such that the initial compressive stress is totally recovered or further compressive stresses result in a total stress that exceeds the yielding point of the material.

In this way, any cyclic stress such  $-R_{p0.2} \leq \sigma(t) \leq S_e$  leads to no crack propagation. From this consideration the resulting Haigh diagram is shown in Fig. 7 and compared to the one normally used for ER7 or ER8 steel grades. This behaviour is in line with the results of other researches,

where failure of compressed notched specimen is reached only when plastic deformation occurs [18].

Monobloc wheels are usually assessed by using the maximum principal stress method (MPSM) [13], which is explicitly applicable only to the assessment of axisymmetric wheels, for which the radial stress is usually dominant with respect to circumferential stress in the wheel web, and therefore the stress distribution for the three load cases repeated for different angular positions, is reduced to a uniaxial load case to be compared with the permissible stress.

Principal stresses and directions are calculated for each node, finding the maximum principal stress  $\sigma_{max}$  and its direction. The smallest minimum principal stress for all load cases is then projected ( $\sigma'_{min}$ ) in the direction of  $\sigma_{max}$ . The alternate stress is therefore  $\sigma_a = \Delta\sigma/2 = (\sigma_{max} - \sigma'_{min})/2$ , while the mean value is  $\sigma_m = (\sigma_{max} + \sigma'_{min})/2$ . This procedure is repeated for all the principal directions and the resulting pairs  $(\sigma_m; \sigma_a)$  are plotted in the Haigh diagram.

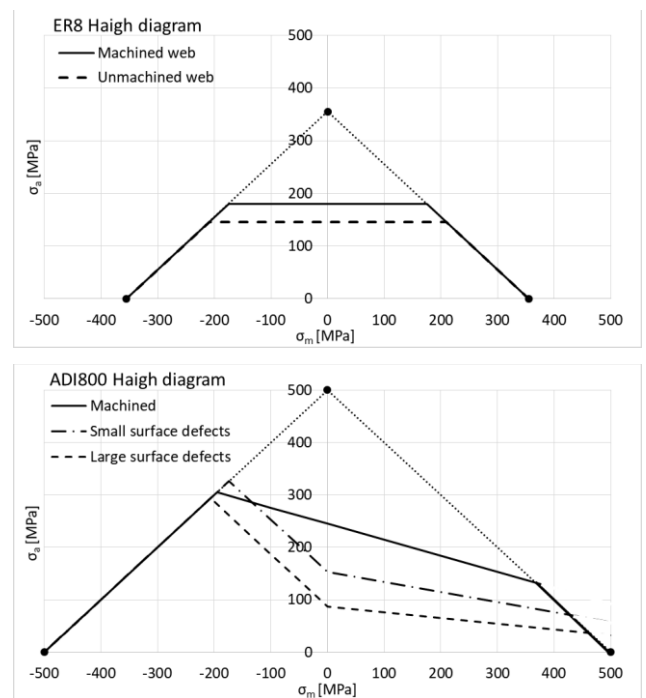

Fig. 7 Haigh diagrams for ER8 steel grade used for monobloc wheels (top) and for ADI800-10 used for the casted wheel centre (bottom).

Wheel web is often not axisymmetric, for example due to the presence of holes (needed for wheel web mounted braking discs) and in this case the hypothesis of dominant radial stress could not be locally satisfied. Therefore, a multiaxial criterion (e.g. Crossland or Dan Vang [13]) should be used, but to the author’s knowledge the MPSM is used also for non-axisymmetric wheels.

As for the new wheel centre the main stress state is the radial compression of the spokes, it is reasonable to apply the MPSM even if the wheel is not axisymmetric. Large part of the spoke is already subjected to uniaxial stress and the application of the criterion is straightforward.

Each load case is applied at  $6^\circ$  interval along the circumference of the wheel for both new tyre and worn tyre. To investigate if the external forces are able to recover the initial compression of the spokes, the worn case is evaluated

considering the minimum tyre fitting interference. The resulting Haigh diagrams, where mean and alternating stress are plotted, are shown in Fig. 8. As the method is conceived to find the principal stresses independently from their directions, projection 33 represents the state stress for all those nodes that are always in compression, i.e.  $\sigma_m + \sigma_a \leq 0$ , while projection 11 is the state stress for the nodes that show a tensile maximum principal stress, i.e.  $\sigma_m + \sigma_a > 0$ . It appears that all stress pairs fall into the “safe region” with reasonably high safety margins, paving the way to further lightening of the wheel centre or, similarly, to the possibility of bearing higher axle loads.

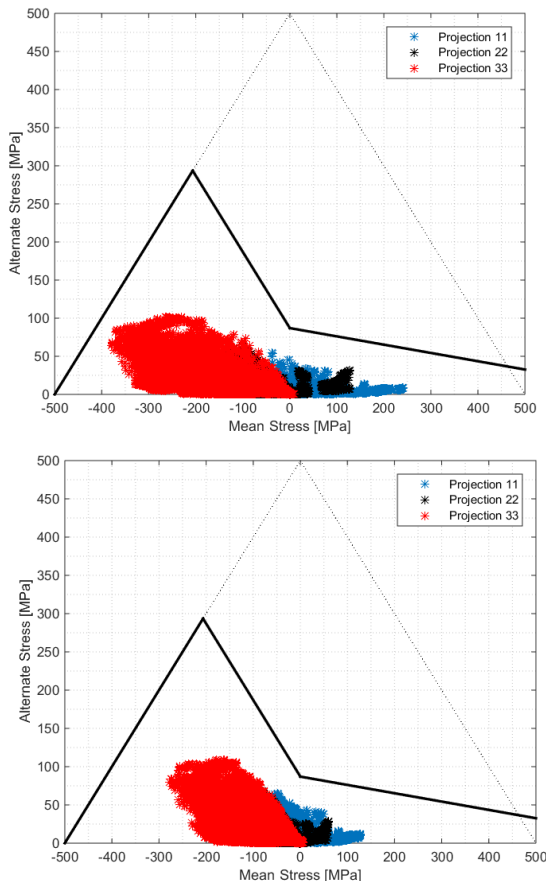

Fig. 8 Haigh diagrams resulting from the fatigue analysis in new tyre condition (top) and in worn tyre condition (bottom).

#### 4. CONCLUSIONS AND FUTURE DEVELOPMENTS

Railway engineering is nowadays focused on the development of lighter and quieter components and wheels have a great impact due to the notable unsprung mass and their interaction with the track.

In this paper a new wheel centre for tyred wheels was introduced, showing that the use of Austempered Ductile Iron (ADI) allows reaching an optimized shape able to reduce tyred wheels mass. Casting simulations and FEM models were used to validate the design, with specific attention to fatigue strength.

ADI mechanical properties for this particular application by means of full scale fatigue tests are investigated in [12]. As cast iron provides a structural damping greater than steel and the lateral surface of the spoked wheel is reduced by around 50%, emitted noise should reduce noticeably. Specific investigations are in progress and will be published soon [19].

Although surface quality can be a critical issue for castings, the initial compression stress due to tyre fitting increases the fatigue limit, resulting in relatively high safety factors. Therefore, results are promising and a further optimization is ongoing.

#### REFERENCES

- [1] D. J. Thompson, *Railway Noise and Vibration*, Elsevier Science, 2006, ISBN 9780080451473.
- [2] M. Große-Hovest, G. Fischer, “Development of an innovative high performance railway wheelset”, *Proceedings of the 7th World Congress on Railway Research “WCRR 2006”*, June 4-8, 2006, Montréal, Canada.
- [3] J. R. Keough and K. L. Hayrynen, “Designing with Austempered Ductile Iron (ADI)”, *Proceedings of American Foundry Society*, Schaumburg, Illinois, USA, 2010.
- [4] ISO 17804:2005, “Founding — Ausferritic spheroidal graphite cast irons — Classification”.
- [5] EN 1564:2011 “Founding - Ausferritic spheroidal graphite cast irons”.
- [6] G. Ianniti et al., “Micromechanical modelling of constitutive behavior of austempered ductile iron (ADI) at high strain rate”, *Theoretical and Applied Fracture Mechanics* Vol. 92, pp. 351-359, 2017.
- [7] A. Ruggiero et al., “ADI 1050-6 Mechanical Behavior at Different Strain Rates and Temperatures”, *Material Science Forum* Vol. 925, pp. 196-202, 2018.
- [8] Y. Okagata, “Design Technologies for Railway Wheels and Future Prospects”, Nippon Steel & Sumitomo Metal technical report, No. 105, December 2013.
- [9] A. Bracciali and G. Megna, “Tyred wheels without braking: structural optimization”, *Proceedings of The Fourth International Conference on Railway Technology, Railways 2018, Spain*
- [10] A. Bracciali et al., “Dovetail Tyred Wheels – Application to a DMU”, *IWC2019 proceedings*.
- [11] A. Bracciali, G. Megna, “Stresses and strains in tyred wheels during tyre fitting process”, *Proceedings of The Fourth International Conference on Railway Technology, Railways 2018, 3-7 September 2018, Sitges, Barcelona, Spain*.
- [12] L. Bociolini et al., “Manufacturing and testing of a tyred wheel with casted ADI wheel centre”, *IWC2019 proceedings*.
- [13] EN 13979-1:2011, “Wheelsets and bogies - Monobloc wheels - Technical approval procedure - Part 1: Forged and rolled wheels”.
- [14] EN 13262:2011, “Wheelsets and bogies - Wheels - Product requirements”.
- [15] I. V. Papadopoulos et al., “A comparative study of multiaxial high-cycle fatigue criteria for metals”, *Int. J. Fatigue* Vol. 19, No. 3, pp. 219-235, 1997.
- [16] EN 1370:2011, “Founding – Examination of surface condition”.
- [17] R. I. Stephens, *Metal fatigue in engineering*, 2<sup>nd</sup> ed., Wiley-Interscience publications, 2000.
- [18] T-Y. Hsu and Z. Wang, “Fatigue crack initiation at notch root under compressive cyclic loading”, *Procedia Engineering* Vol. 2, pp. 91–100, 2010.
- [19] A. Bracciali, G. Megna, “Rolling noise emitted by tyred wheels with cast iron spoked wheel centre”, accepted for presentation at 23rd International Congress on Acoustics - ICA 2019 09-13 September, Aachen, Germany

#### Author information



First (Main) author: Gianluca Megna  
 Title: Researcher  
 Research Field: structural design of wheelset components  
 Contact Address: via di Santa Marta 3, 50139 Firenze, Italy, c/o Department of Industrial Engineering, University of Florence, Italy. Tel. +39 055 2758700