

# Experimental and numerical activity on a prototype ejector chiller

**J Mahmoudian, F Mazzelli, A Milazzo and A Rocchetti**

Department of Industrial Engineering – University of Florence – 3, via Santa Marta – 50139 Florence (ITALY)

Corresponding author e-mail: [adriano.milazzo@unifi.it](mailto:adriano.milazzo@unifi.it)

**Abstract.** Research activity on ejectors is ongoing at the University of Florence since the late nineties. The most important achievement is a 40 kW ejector chiller designed according to the “CRMC” criterion. The experimentally validated CFD simulations have given some hints about some possible improvements, i.e. refine the surface finish of the ejector, study the effect of heat transfer and improve the final part of the diffuser, which in its present shape does not produce a measurable compression. The prototype has been recently filled with low-GWP refrigerant R1233zd, as a drop-in replacement of previously used R245fa. Both fluids are “dry-expanding” and hence significantly easier to model in CFD simulations. Synthetic low-GWP refrigerants may be an option for ejector chillers, due to their ability to reach below-zero temperature and high volumetric refrigerant capacity. Some lessons learned with synthetic refrigerants can be transferred to the project of a steam ejector chiller, which remains one of our future targets. Herein we resume the principal findings gathered by means of experimental and numerical activity on our prototype and propose a few ideas for the future research.

## 1. Introduction

Ejectors are used worldwide for a variety of purposes (e.g. vacuum processing, water treatment, fluid and solids handling, etc.). Some companies (e.g. GEA [1]) use steam ejectors for cooling systems where a liquid is directly cooled by flashing it at low pressure. According to Power [2], if steam is available for other purposes, a steam ejector chiller is the simplest and cheapest cooling system on large scale plants. Actually, steam ejector chillers have been extensively used in the past as long as steam has been commonly available as a by-product of steam engines and heating systems [3].

The literature on refrigeration has reported a huge amount of work on ejector chillers, since the fundamental work of Keenan [4]. Very soon other working fluids have been proposed in lieu of steam [5, 6], but none of them has been universally recognized as the best option. For sure, water is costless, available everywhere and safe for environment and operators. On the other hand, synthetic fluids may guarantee operation below 0°C, higher volumetric refrigeration capacity and, in some cases, dry expansion within the ejector.

Our research group started studying ejectors in the ‘90s and produced a first prototype of steam ejector chiller in the early 2000s [7]. This prototype had a peculiar two-stage configuration, with an annular primary nozzle in the second stage and a direct connection of the second stage to the first one, aimed at reducing velocity variations along the ejector.

In 2009 we started a cooperation with Frigel s.p.a., an international producer of industrial cooling systems based in Florence. Frigel was willing to test new solutions for heat-powered refrigeration on industrial scale and hence asked for a rather powerful prototype with reduced footprint. This prompted

us for a change of operating fluid, in order to reduce the size of heat exchangers and other components. Finally, R245fa was selected as the working fluid and a prototype producing chilled water (7-12°C) with a nominal cooling power of 40 kW was built. First experimental results arrived in 2011 [8]. Since then, the prototype has been continuously improved in many respects, as shown in detail in what follows.

## 2. Design issues

The main structure of our prototype has remained unchanged since the initial phase. A vertical layout saves floor-space and guarantees a substantial liquid head between the condenser (on top) and the generator feed-pump (on the bottom). This latter is a multi-stage side-channel pump, featuring a good resistance to cavitation. Over-dimensioned plate heat-exchangers are used as condenser, evaporator and generator. The ejector is placed vertically, with upward flow direction. Figure 1a shows the prototype, seen from above, in its previous location at Frigel. Since 2017 the prototype has been moved to our laboratory. In the present configuration (figure 1b) the generator is heated-up by an electric-oil heater, in order to facilitate the experimental activity without external constraints. In practical application the heat source could be either solar or waste heat in a temperature range around 100°C. A cooling tower feeds a buffer tank providing a constant temperature water source. The buffer tank gives the cooling water to the condenser and the cooling load to the evaporator through temperature controlled circuits.

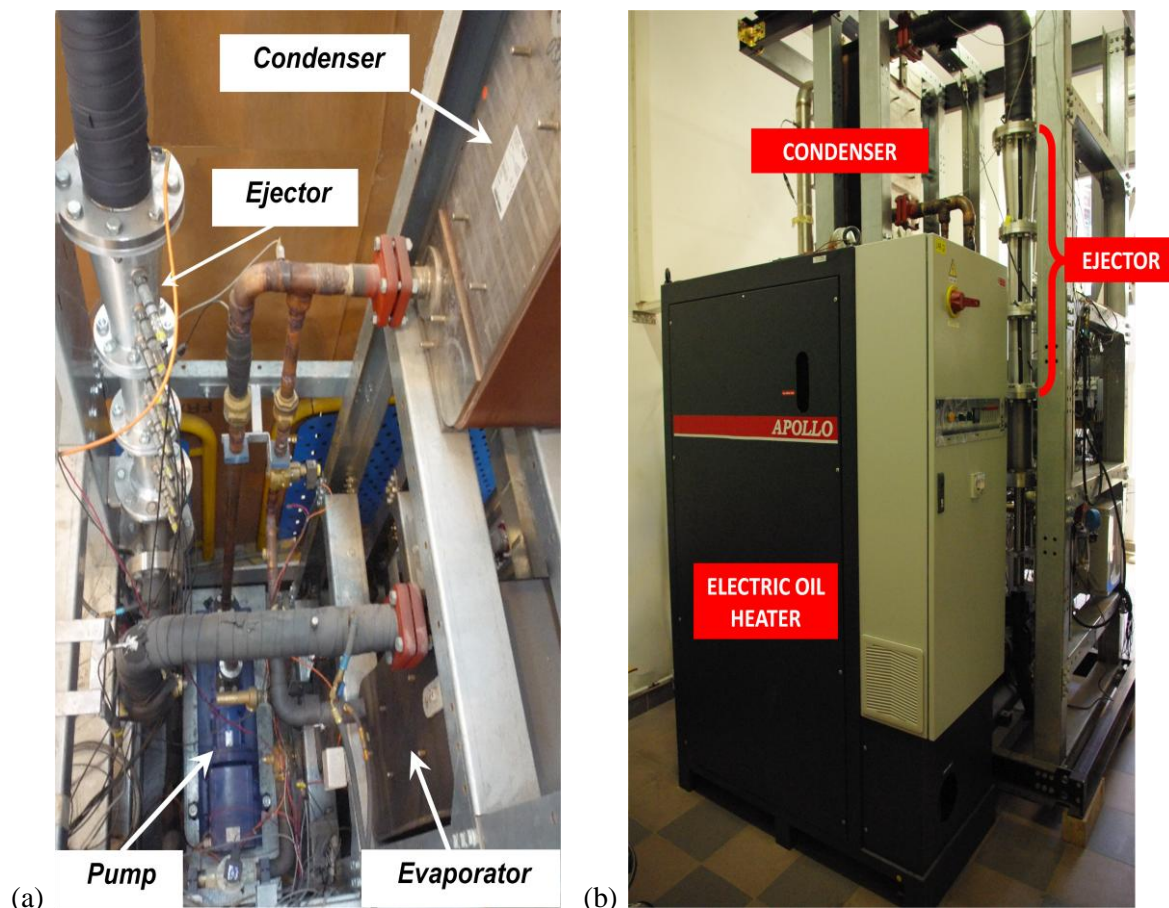

Figure 1 – Side and top views of the prototype

### 2.1. Design of the ejector

From the onset of our research project, the CRMC criterion was selected as the key procedure for the ejector design. Introduced in 2002 by Ian Eames, who has been personally involved in our project, this

criterion is probably the first attempt to set a procedure for a real 1-d design of the ejector [9]. The commonly used model by Huang et al. [10], on the contrary, calculates only the diameter of the cylindrical part of the ejector, without any specification on its length or the angle of the convergent and divergent sections, etc. The continuous profile generated by the CRMC criterion is free from sharp turns of the flow and may be easily optimized by setting the rate of momentum change, which dictates the length of the diffuser. The benefit in terms of efficiency, either in terms of entrainment ratio or compression ratio, has been demonstrated by various authors. Eames et al. in 2006 [11] reported experimental results on a CRMC ejector chiller working with R245fa and showed that, for saturation temperatures of 110°C at generator and 10°C at evaporator, the COP could be as high as 0.47, with a critical condenser temperature of 32.5°C. Recently Kittrattana *et al* [12] reported a comparison between a CRMC and a conventional steam ejector and found that the CRMC, in the same conditions, offers a 40% higher entrainment ratio. Obviously the CRMC criterion could be improved in many respects. First of all, this procedure concentrates on the design of the supersonic diffuser, assuming a fully mixed flow at its entrance. Experimental and numerical evidence proves that actually the mixing between primary and secondary flow continues along the ejector, well beyond the diffuser throat. Therefore, a two dimensional criterion, or at least a “two zone” model accounting for the survival of two distinct flows with different velocities, should be formulated.

When we started our work on the present prototype, our aim was to introduce in the CRMC criterion the effects of friction and real gas behaviour. A complex shape, featuring a bell-shaped inlet, a short CRMC section and a conical exit was hence designed, as described in [13]. However, this first ejector proved to be rather unsuccessful, as reported in [8]. Therefore we resolved to use a scaled-up version of the existing ejector described in [11], modifying only the final part, that was shaped as a cone. A section of this final design is shown in figure 2. The dimensions (in mm) refer to the positions of the pressure transducers along the ejector. The tube that supports the primary nozzle can move axially through the inlet flange in order to optimize its position. Here the nozzle is shown in its reference position (aligned with the flange), which turned out to be the best. For convenience, the main geometrical parameters of nozzle and ejector are recalled in table 1.

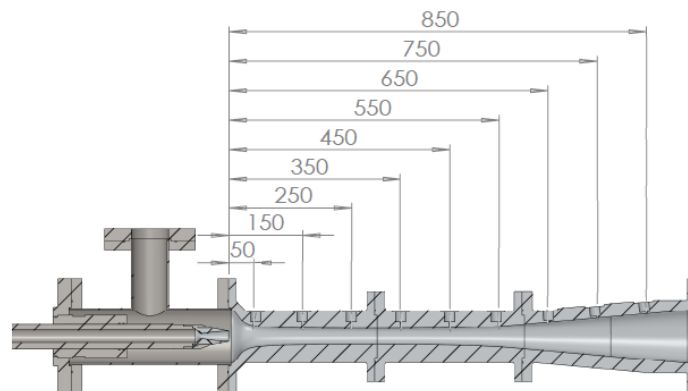

Figure 2 – CRMC ejector in its present design

**Table 1.** Main geometrical parameters of the ejector

	Nozzle	Diffuser
Throat diameter [mm]	10.2	31.8
Exit diameter [mm]	20.2	108.3
Length [mm]	66.4	950
Material	Aluminium	Aluminium

## 2.2. Design of the primary nozzle

The primary nozzle has been the subject of a specific optimization. The first nozzle was dimensioned according to purely thermodynamic criteria, as described in [13], and designed with a conventional shape, featuring a rounded inlet and a straight cone at exit. When the first CFD simulations were available, the nozzle clearly proved to be over-expanded, i.e. the exit section had an excessive diameter and hence produced a primary flow at exceedingly low pressure. In a supersonic ejector, as explained in detail in [3], this low pressure does not increase the “suction” of entrained flow, but rather causes intense oblique shocks at the interface between primary and secondary flows, increasing energy losses. A new primary nozzle was then designed and optimized by CFD analysis. A detailed comparison between the old and the new design is described in [14].

## 2.3. Choice of the working fluid

The initial choice of R245fa as the working fluid proved to be very successful. However, high GWP makes this fluid unusable in developed countries and, in perspective, anywhere. Therefore, other fluids should be considered. A comparison between several alternatives has been published by our group in [15]. This comparison was based on a thermodynamic ejector model accounting for real gas properties and adapting the ejector geometry to each gas by the CRMC criterion. Obviously, this purely thermodynamic analysis should be experimentally validated. However, following the outcome of this study, we concentrated on the best performing fluid, i.e. low-GWP refrigerant R1233zd. By the way, this fluid is very similar to R245fa in terms of thermodynamic properties and hence, for a first screening, the prototype can be left completely unchanged, even if some optimization could be useful. Another surprising result from the fluid comparison in [15] was the high performance of steam, contradicting the results from other authors, e.g. [16]. Incidentally, the literature reports also experimental results that claim superior performance of steam ejectors [17]. Apparently, further work is needed on this point.

# 3. Experimental and numerical results

## 3.1. Brief summary of previous results

The prototype ejector has undergone several test campaigns since its completion in 2011. A continuous interaction between numerical and experimental analysis has highlighted a few points which in part have already been published elsewhere [e.g. 14, 18]. The first point concerns the effect of surface roughness of the ejector inner wall. As shown in [14], the numerical results can be brought to very good agreement with the experiments by using the wall roughness treatment available in the ANSYS Fluent code. On the other hand, the CFD analysis shows that a smooth ejector wall would give significantly higher performance, particularly in terms of compression ratio. As already well known, the best possible surface finish should be pursued when building the internal flow passage within the ejector.

A second point concerns the heat exchange at ejector walls, which is normally neglected in thermodynamic and CFD studies. As shown in [18], CFD analysis yields values of convective heat transfer coefficient ranging from 3000 to 4000 W m<sup>-2</sup> K<sup>-1</sup>, making the assumption of adiabatic wall rather questionable. The effect of heat exchange should hence be analyzed and eventually the wall material and structure should be selected/optimized in order to control the heat transferred to the environment and along the ejector.

A third point concerns the diffuser shape on the exit side. The decision to add a conical part to the end was originally taken in order to avoid flow detachment from the diffuser wall, which was likely to take place in the final part of the CRMC profile. The CRMC criterion was conceived to control the average angle of divergence, the local angle being free to reach high values at the end. Our design truncates the CRMC profile as soon as it reaches an angle of divergence of 5° and keeps this angle till the exit diameter, forming a straight cone. The pressure profile measured along the ejector, however,

has unmistakably proven that the conical termination of the diffuser gives a very scarce contribution to pressure recovery, if any. Therefore, an improved design is needed for this part of the ejector.

The last point concerns the operating fluid. R245fa was used until 2018, when the prototype was tested at sub-zero evaporator temperature [19]. Then the prototype was emptied and refilled, without any modification, with R1233zd. Some experimental results obtained with the new fluid are shown in this paper for the first time. In order to compare these new results to those obtained with the old fluid, we recall in table 2 the results already published in [14]. Note that the saturation temperature at the generator  $T_{Gsat}$  was rather low in those tests, giving a relatively low motive flow through the primary nozzle. This choice produces high COP but a relatively low critical temperature at the condenser. The energy balance of the ejector yields a trade-off between a high entrainment ratio (i.e. high COP) and a high compression ratio. This latter performance parameter requires a high primary flow rate, in order to “push” the transition from super to sub-sonic flow along the ejector, notwithstanding a high discharge pressure.

**Table 2.** Performance of the ejector chiller working with R245fa [14].

$T_{Esat}$ [°C]	$T_{Gsat}$ [°C]	Critical $T_{Csat}$ [°C]	On design COP
5	89	28	0.41
10	90	29.5	0.55

**Table 3.** Specifications of the transducers and data acquisition modules

Instrument	Model/type	Position	ADC Module	Total uncertainty
Piezoresistive pressure transducer	PA25HTT 0-30 bar	Diffuser	NI9208	$\pm(0.1\% + 0.22\% \text{ FS})$
	PR23R 0.5-5 bar	Evaporator	NI9208	$\pm(0.1\% + 0.22\% \text{ FS})$
	PA21Y 0-30 bar	Generator, Condenser	NI9208	$\pm(0.08\% + 1.0\% \text{ FS})$
Thermoresistance	Pt100	Whole plant	NI9216, NI9217	$\pm 0.25^\circ\text{C}$
Thermocouple	T	Whole plant	NI9213	$\pm 1.0^\circ\text{C}$
Electromagnetic water flowmeters	Endress Hauser Promog 50P	Condenser	NI9219	$\pm(0.5\% + 0.04\% \text{ FS})$
Coriolis flowmeter	Yokogawa RCCT28	Evaporator	NI9219	$\pm(0.05\% + 0.1\% \text{ FS})$
Vortex flowmeter	Yokogawa YF105	Generator	NI9219	$\pm(0.8\% + 0.1\% \text{ FS})$

### 3.2. New experimental results

The experimental set up extensively described in [14] has been slightly modified when the chiller was moved to our laboratory. The data acquisition system in its present configuration, described in table 3, is mostly unchanged. The most important modification is represented by the higher temperature of the hot fluid supplied by the electric heater that feeds the generator. The heater has different specifications from the one used at Frigel because, given the lower saturation pressure of R1233zd, a higher temperature was thought to be necessary. Higher generator temperature was also desirable in order to raise the allowable condenser temperature, in view of future applications in warm climates. Therefore old and new results are not immediately comparable, the generator temperature being now between 103 and 104°C. As expected, the COP is invariably lower, though the critical condenser temperature is significantly higher. In any case, it may be stated that the chiller performance is globally equivalent and the new fluid may be an effective drop-in substitute of the old one.

Saturation temperatures below 0°C can be easily reached at evaporator, as was already proven with the old fluid, even if obviously entrainment and compression ratio are both quite poor and on-design operation is possible only for very low temperature at the condenser. The chiller works in stable and reproducible manner and easily recovers after a period of off-design operation, as soon as the condenser temperature is brought back to the design zone.

The four different performance curves in figure 3 show the well known behaviour of supersonic ejector chillers, featuring increasing COP and critical condenser temperature with increasing saturation temperature at evaporator. At high evaporator temperature the off-design condition takes place in a more gradual way, with relatively stable, though deteriorated, operation even at condenser temperatures significantly above the critical value. At lower evaporator temperatures the off-design lines are much steeper. Table 3 shows the cooling power and the electric power absorbed by the pump. This latter is quite low, yielding an “electric” COP between 10.5 and 16.7.

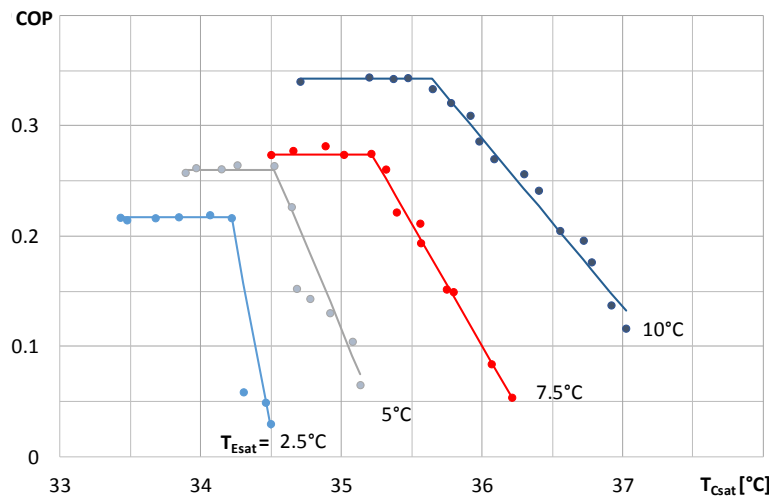

Figure 3 – COP of the chiller operated with R1233zd –  $T_{Gsat} = 103^{\circ}\text{C}$

**Table 3.** Performance of the ejector chiller working with R1233zd.

	$T_{Esat} [^{\circ}\text{C}]$			
	2.5	5	7.5	10
Cooling power [kW]	21.66	26.14	28.24	34.6
Pump power [kW]	2.07			

A more detailed description of the ejector operation may be gathered from the observation of the pressure profile along the ejector. The spacing between the transducers (100 mm – see figure 2) does not allow a precise positioning of the shock train, but is sufficient to get a general picture and to discriminate between on and off-design working conditions. Note that the lines in the following figures are meant only to connect the experimental points referred to a single working condition and do not describe the pressure behaviour between the transducers. Starting from the bottom, each line in figure 4 corresponds to a point (from left to right) in figure 3. The diffuser throat is located between transducers 3 and 4. For completeness, the readings of the pressure transducers at evaporator exit and at condenser inlet have been added (columns “E” and “C”).

As can be seen in figure 4a, the pressure profiles referred to a low evaporator saturation temperature ( $2.5^{\circ}\text{C}$ ) are easily divided in two well distinguishable groups, one below the critical condenser temperature and one above. The lines numbered from 1 to 6 (corresponding to 6 points on the plateau of the “ $2.5^{\circ}\text{C}$ ” curve in figure 3) have coincident pressure values on the first two transducers, slight variations on the third one and a pressure jump before the fourth, whence the flow is surely subsonic. Curves 7,8 and 9 (corresponding to 3 points at bottom of line “ $2.5^{\circ}\text{C}$ ” in figure 3) start to diverge since the first transducer, proving that the flow is subsonic throughout the ejector.

On the other hand, figure 4b, referred to  $10^{\circ}\text{C}$  saturation temperature at evaporator, shows an almost continuous evolution of the pressure profile. Actually, lines from 1 to 4 still have almost coincident pressures up to the second transducer (corresponding to the points on the plateau of the “10” line in figure 4). However, the other lines are equally distributed between the on-design profile

and an extreme working condition (line 16) where the chiller produces very scarce cooling. At this point the experiment is stopped, in order to avoid backflow from the condenser to the evaporator. The intermediate conditions shown in figure 3 on curves “5°C” and “7.5°C” place themselves in between the two extreme cases and are therefore omitted.

In all cases, a remarkable pressure reduction occurs between transducers “8” and “9”. As anticipated, this is probably due to a poor design of the last part of the ejector and/or to a flow recirculation. A pressure recovery occurs in the elbow that connects the ejector to the condenser inlet, where the “C” pressure transducer is located, but this recovery does not even compensate the loss occurred upstream. Hopefully an amended design of the ejector exit zone would increase the compression capability of the ejector.

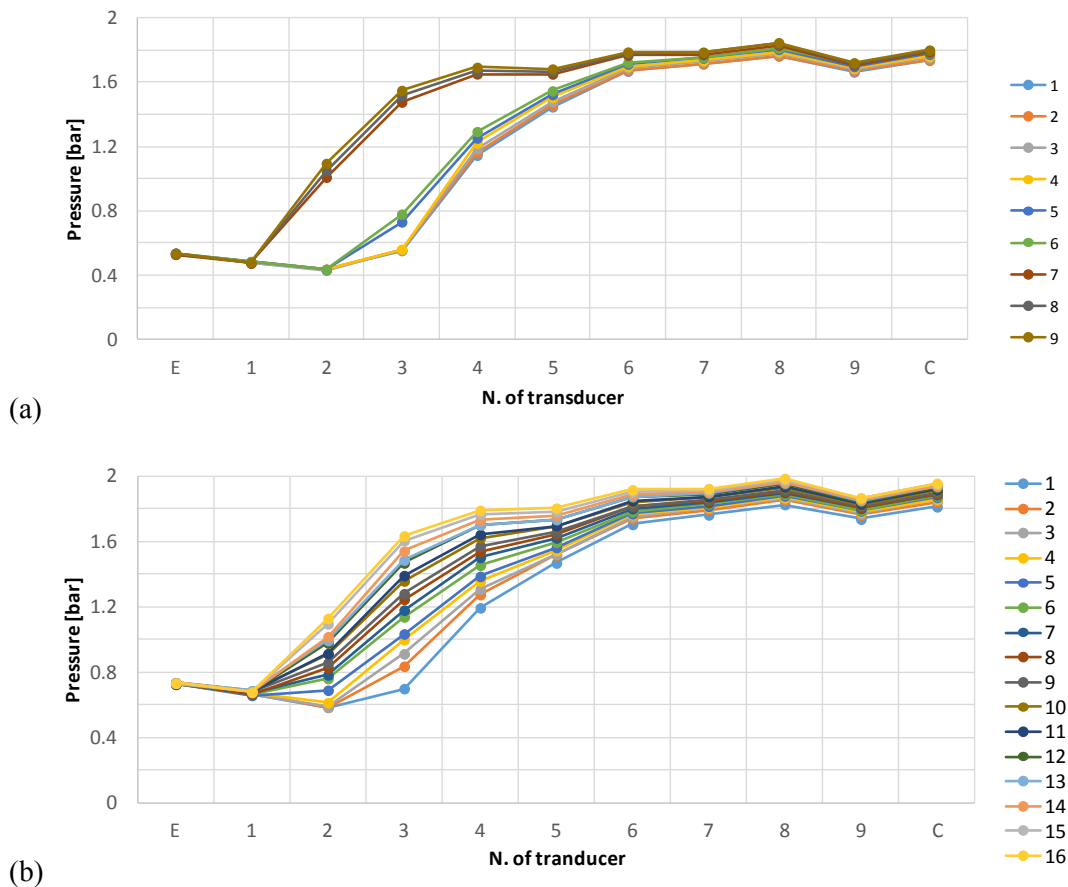

Figure 4 – Pressure values along the ejector – (a)  $T_{\text{Esat}} = 2.5^{\circ}\text{C}$ ; (b)  $T_{\text{Esat}} = 10^{\circ}\text{C}$

#### 4. Conclusions

The experimental data shown in this paper prove that the satisfactory results obtained by our CRMC ejector chiller with the refrigerant R245fa can be replicated with the low-GWP, drop-in substitute R1233zd. The trade-off between high entrainment ratio (i.e. high COP) and high compression ratio (i.e. high condenser temperature) has been moved towards the latter in the new experiments. However, the performance given by the two refrigerants is substantially aligned. A significant amount of work is still needed in order to optimize the chiller, i.e. increase its performance and reduce its cost. The ejector design seems to offer a quite large space for improvement. The most evident point is the shape of the conical part on the exit side, which should be optimized by a CFD analysis. Other points requiring further effort are the wall surface roughness, which should be kept to a minimum, and the wall heat exchange, which should be analyzed and integrated in the ejector optimization.

Ejector chillers can be useful as a low cost alternative for LiBr absorption chillers and, when using synthetic refrigerants, have further benefits in the capability to reach sub-zero temperatures and the

high volumetric cooling capacity, which reduces the size and cost of heat exchangers with respect to steam. Obviously, these pros must suffice to counterbalance the higher cost of the refrigerant. Furthermore, the environmental safety of the R1233zd needs to be proved on the long term.

## 5. References

- [1] <https://www.gea.com/en/products/steam-jet-cooling-systems.jsp> (visited 9/5/2019)
- [2] Power, R.B., *Steam Jet Ejectors for the Process Industries*, Author-Publisher, 1994, [www.jetwords.com](http://www.jetwords.com)
- [3] Grazzini G, Milazzo A and Mazzelli F 2018 *Ejector for Efficient Refrigeration*, (Springer)
- [4] Keenan H, Neumann EP, Lustwerk F 1950 An investigation of ejector design by analysis and experiment. *J. Applied Mechanics*, Trans. ASME **72** 299–309
- [5] Dorantes R and Lallemand A 1995 Prediction of performance of a jet cooling system operating with pure refrigerants or non-azeotropic mixtures. *Int. J. Refrigeration*. **18**, 21–30
- [6] Sun D-W 1999 Comparative study of the performance of an ejector refrigeration cycle operating with various refrigerants. *Energy Conversion Management* **40**, 873–884
- [7] Grazzini G and Rocchetti A 2002 Numerical optimisation of a two-stage ejector refrigeration plant. *Int. J. Refrigeration* **25**, 621–633
- [8] Eames I W, Milazzo A, Paganini D and Livi M. 2013 The design, manufacture and testing of a jet-pump chiller for air conditioning and industrial application. *Applied Thermal Engineering*, **58**, 234-240
- [9] Eames I W 2002 A new prescription for the design of supersonic jet-pumps: the constant rate of momentum change method, *Applied Thermal Engineering*, **22**, 121-131
- [10] Huang B J, Chang J M, Wang C P and Petrenko V A 1999 A 1-D analysis of ejector performance, *Int. J. Refrigeration*, **22**, 354–364
- [11] Eames I W, Ablwaifa A E and Petrenko V 2007 Results of an experimental study of an advanced jet-pump refrigerator operating with R245fa, *Applied Thermal Engineering*, **27**, 2833-2840
- [12] Kittratana B *et al.* 2017 Comparison of traditional and CRMC ejector performance used in steam ejector refrigeration, *Energy Procedia* **138**, 476-481
- [13] Grazzini G, Milazzo A and Paganini D 2012 Design of an ejector cycle refrigeration system, *Energy Conversion and Management*, **54**, 38-46
- [14] Mazzelli F and Milazzo A 2015 Performance analysis of a supersonic ejector cycle working with R245fa, *Int. J. Refrigeration*, **49**, 79-92
- [15] Milazzo A and Rocchetti A 2015 Modelling of ejector chillers with steam and other working fluids, *Int. J. Refrigeration*, **57**, 277-287
- [16] Varga S, Lebre P S and Oliveira A C 2013 Readdressing working fluid selection with a view to designing a variable geometry ejector, *Int. J. Low Carbon Technology*, **0**, 1-11
- [17] Chunnanond K and Aphornratana S 2004 An experimental investigation of a steam ejector refrigerator: the analysis of the pressure profile along the ejector, *Applied Thermal Engineering*, **24**, 311-322
- [18] Milazzo A and Mazzelli F 2017 Future perspectives in ejector refrigeration, *Applied Thermal Engineering*, **121**, 344–350
- [19] Mahmoudian J, Milazzo A, Murmanskii I and Rocchetti A 2018 Experimental Results from a R245fa Ejector Chiller, Heat Powered Cycles Conference, Bayreuth

## Acknowledgments

The research presented herein has received funding from the MIUR of Italy within the framework of PRIN2015 project “Clean Heating and Cooling Technologies for an Energy Efficient Smart Grid”, from the “Fondazione Cassa di Risparmio di Firenze” and from the “Fondazione Cassa di Risparmio di Pistoia e Pescia”. A special thank to Dr. Davide Refosco of Honeywell Performance Materials & Technologies for providing the fluid R1233zd.