

PAPER • OPEN ACCESS

Design of a seasonal storage for a solar district heating in Florence

To cite this article: M Salvestroni *et al* 2019 *IOP Conf. Ser.: Mater. Sci. Eng.* **556** 012026

View the [article online](#) for updates and enhancements.

Design of a seasonal storage for a solar district heating in Florence

M Salvestroni¹, G Pierucci¹, F Fagioli¹, A Pourreza¹, M Messeri¹, F Taddei¹, S Hosouli¹, H Rashidi¹ and M De Lucia¹

¹ Department of Industrial Engineering of University of Florence,
Via di Santa Marta 3, 50139 Florence – Italy
E-mail: michele.salvestroni@unifi.it

Abstract. The energy demand in residential sector constitutes an important fraction of the entire energy consumption (40% in EU). Solar district heating (SDH) is a key strategy to reduce use of fossil fuels in buildings. Inside the European project REPLICATE, financed by Horizon 2020 SCC1 Smart Cities and Communities, a SDH with a seasonal storage (STES) has been designed to be realized in the city of Florence. It is the first example of solar district heating with a STES in Italy. The design phase has aimed to size properly the extension of solar field and the volume of seasonal storage based on several parameters such as number of dwellings to feed, heat demand, solar resource, geology of the location and economic reasons. The paper deals with the model that has been realized through TRNSYS to describe the energy fluxes of heating plant and their optimization process. The computational model depicts the possible operating conditions and leads to define the control strategies of solar field and seasonal storage, integrated with commercial components that complete the plant such as gas boiler, heat pump and overall circuit. Hot water tank TES has been selected as the appropriate typology of storage for this application based on geological considerations. The thickness of insulation material and various layers have been determined. The numerical analysis fixes the volume of TES to be 3800 m³ and a solar field of about 1000 m². The solar fraction expected by the district heating is 44%.

Keywords: Seasonal storage, solar district heating, TRNSYS

1. Introduction

The energy demand in residential sector constitutes an important fraction of the entire consumption of energy, counting for the 40% in EU [1].

In order to reduce the use of fossil fuels and the emissions of greenhouse gases caused by buildings, the integration of renewable energies, solar technologies in particular, plays an important role.

A very promising strategy is represented by the concept of solar district heating (SDH) in which the heat, provided by solar thermal collectors, is stocked in a seasonal thermal energy storage (STES or TES) during spring and summer to release it during autumn and winter [2]. In this way it is possible to increase considerably the amount of heat produced by solar technologies respected to the total heat demand, which is called solar fraction.

Many examples of SDH with STES are present in Europe. The countries that have invested more in this field are Denmark, Germany and Sweden [3-6]. In Italy few solar district heating have been developed in recent years but they are not associated with a seasonal storage.

The city of Florence is participating at the European project Replicate, financed inside the program Horizon 2020 SCC1 Smart Cities and Communities. Among the actions to undertake, it is planned the improvement of energy performances of two social housing (300 dwellings) and the realization of a



solar district heating with seasonal thermal storage (first case in Italy). In this context, a solar field and a tank seasonal storage have been designed.

A model has been realized through TRNSYS in order to evaluate the features of all the components in the heating plant (gas boiler, solar field, seasonal storage, etc.) and their interactions. The TRNSYS model highlighted the parameters that most influence the behavior of the system.

2. TES design

The design of a seasonal thermal energy storage deals with geological aspects, constructional features, energetic and economic issues.

First of all, the composition of the ground of area interested by the district heating project is not suitable for a borehole storage or an aquifer storage. Moreover, a comparison between pit storage and water tank storage has led to select the latter one as the appropriate for the project thanks to the best insulation performances that it guarantees.

In general a water tank STES is a complex structure composed by several layers of different materials. From the inside to the outside is as follows: a liner made by stainless steel or polymer to obtain water tightness, a concrete layer to support the structure, a vapor barrier against water permeation, and an insulation layer to reduce thermal losses [5-6]. In this project it has been decided to use a water tightness high density concrete without liner. Expanded glass granules have been selected as insulation material.

The design strategies are strongly affected by the project site. In this case, the Florence city rules forbid to build structures over the ground near the river Arno, due to flood problem, so that the STES must be almost fully underground. This fact limits the height of the storage because of the presence of aquifer 10 m below the ground level. There are no limitations for the width of the storage.

The TES needs to be designed carefully since its thermal performance, the amount of heat stored and its optimal dimensions are dependent and connected to many variables, such as: the radiation resource, the heat user demand, the size of solar field, the target solar fraction of the district heating, the supply and return temperature of the district heating, parameters related to its geometries (aspect ratio), constructive solutions (thermal properties of materials, layers width, etc.), characteristics of district heating net (pipe length, insulation, etc.).

Due to complexity of the system, a numerical analysis is necessary to design properly a seasonal thermal energy storage. The solar field, from project, must guarantee 750 MWh/y minimum and available solar field area is limited by the roof buildings (**Error! Reference source not found.**).



Figure 1 Picture of the buildings and of the area that will be retrofitted. The sectors available for solar field are highlighted. Between the two buildings the area where TES will be built.

A numerical analysis, considering mutual shadowing and external shadows, has been conducted to find the configuration of the solar collectors that guarantees the maximum amount of heat collected. The inclination of collectors and the distance between them have been varied: in **Table 1** some configurations are reported.

Table 1 Different configurations for solar field. Temperature of inlet flow fixed at 80°C.

Inclination (°)	Net area of collectors (m ²)	Total energy (MWh)
25	504	354
15	792	544
15	864	585
10	1008	687

As can be seen, the maximum value for annual energy is reached filling the available area with the maximum number of collectors (i.e. net area of collectors), even if the tilt angle is not the theoretical optimum and shadows could occur between the rows of the solar field during the morning and the evening. This analysis has been used only to compare different configurations since the heat produced by solar field is strongly dependent from TES capacity and heat demand.

The performances of district heating (storage, solar field) strongly depend from the supply and return temperature of the heating plant. The return temperature from heating net fixes the minimum temperature of TES.

In this project, due to the presence of radiators in the dwellings, the supply and return temperature are quite high (66 °C and 51°C). Therefore, it would not be possible to fully discharge the storage and the temperature inside the TES would be limited between 95°C and 50°C, reducing strongly the storage capacity.

Following the international experience [7], a water-water heat pump, linked to TES, has been chosen to extract heat from TES and discharge it completely down to 25°C. In this way, the heat pump increases the capacity in producing heat by renewable energy source and the solar fraction of the district heating grows.

Figure 2 shows the layout scheme created in TRNSYS for the SDH. It can be seen it is divided in several loops that separate different hydraulic circuits. The solar field pump is switched on if solar radiation is available and circulates the water which is heated up to 120°C. When the temperature in solar field is higher than TES temperature, heat is transferred to the storage. The stored heat is then delivered to users. The gas boiler and the heat pump are inserted to supply heat in case of need. The heat pump uses TES as the source of heat (evaporator side), while the user is the sink (condenser side).

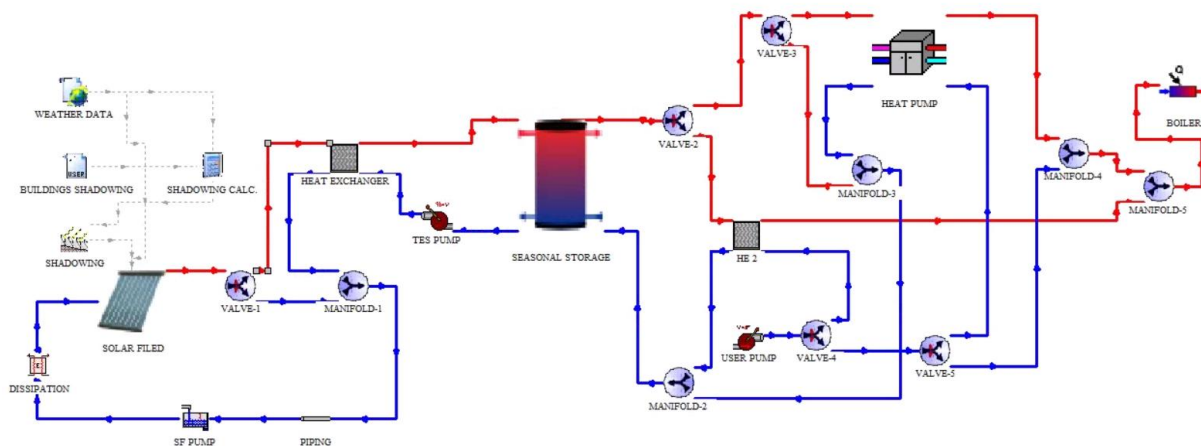

Figure 2 Layout scheme in TRNSYS.

In **Table 2** a part of the results of parametric analysis has been reported. The heat demand requested by the two buildings has been calculated to be 1522 MWh/y. The surface of the solar field is fixed to 1000 m². The shape of TES is supposed to be cylindrical. The coefficient of heat loss for the TES, has been fixed to 0.2 W/(m²K). This precautionary value has been selected considering that the measured heat losses in the thermal energy storages built in Europe have been considerably higher, up to 50-60% than expected [8].

In the first column of the table it is reported an important parameter for TES, the ratio between surface and volume (S/V), that represents the ratio between heat losses and thermal capacity of storage. Increasing the volume of the storage, the ratio decreases. Heat collected by solar field does not coincide with heat delivered by solar field to TES because of losses in the pipe that connects solar field and TES.

Table 2 Results of TRNSYS simulations for different volume of TES.

Volume (m ³)	S/V (m ⁻¹)	Heat collected by SF (MWh)	TES Losses (MWh)	Heat from TES to user (MWh)	Heat from TES to user directly (MWh)	Heat from TES to user by HP (MWh)	Maximum TES temperature (°C)	Solar Fraction (%)
1500	0.49	625	50	554	304	250	94	36
2500	0.43	701	69	609	322	287	94	40
3800	0.38	780	90	668	356	312	92	44
5000	0.37	808	105	682	355	327	82	45
6000	0.35	818	115	684	344	340	73	45

From **Table 2**, it is observed that the smaller volumes of TES does not allow to reach the target production of heat by solar field since TES capacity is small and TES is fully charged at the beginning of summer season. Solar fraction is 36-39%.

For larger volumes the energy produced by SF overcomes the target value, thanks to the higher capacity of the storage and the solar fraction grows up to 44-45%. The amount of useful heat delivered to the users from TES, passing from 3800 m³ to 5000 m³ rises weakly (only 15 MWh more) since heat losses increases although average temperature of TES decreases. Because of the external constraints (underground water) in this project case, the aspect ratio of TES, height to diameter, is far from the ideal condition. In order to increase the volume of the storage it is only possible to increase the width of the tank, lowering further the aspect ratio. This leads to the increase of the surface and of heat losses.

Finally, with the SF net aperture area and the height of TES fixed, there are no energy advantages to build a storage bigger than about 4000 m³. The additional costs of excavations and of materials that will rise for a bigger storage are not justified.

The size of 3800 m³ has been selected as the optimal volume for TES in this project. It is the trade-off between energetic performance and costs. The solar fraction expected for this configuration is 44%. It is worth to notice that the introduction of heat pump allows to rise remarkably the solar fraction of the solar district heating as reported in **Table 3**. For a TES volume of 3800 m³, it passes from 35% to 44%.

Table 3 Comparison of performances in case without and with HP for TES volume 3800 m³.

Hp	Heat by SF (MWh)	Heat from TES to user (MWh)	Minimum TES temperature (°C)	Solar Fraction (%)
No	686	535	51	35
Yes	780	668	23	44

The enhancement of energy performances is due to the better discharge of TES, as it can be seen from TES minimum temperature reported in table.

It is important to notice that the heat pump used in simulations is a commercial water-water heat pump. Selecting a heat pump with better performances, the solar fraction could be improved further

lowering the minimum temperature to 10 °C. **Figure 3** shows the variation of average TES temperature during a year.

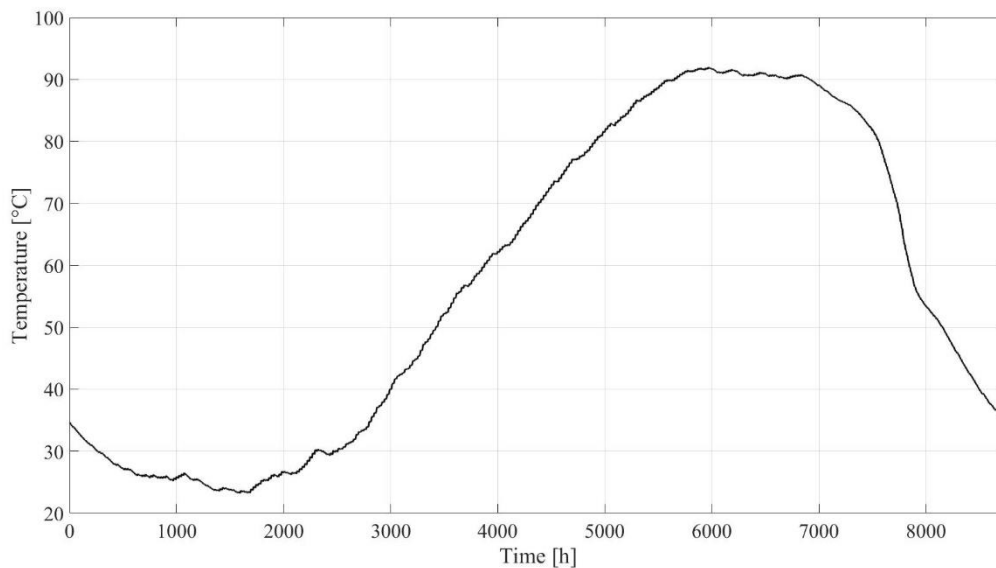

Figure 3 Temperature profile inside the seasonal storage.

The TRNSYS model has also allowed to establish the best control strategies for the district heating. The different operating conditions of the SDH can be explained through **Figure 3**. At the beginning of spring, TES is discharged and the SF starts to transfer heat to it. The charging process continues during summer time when irradiation from Sun is high and the user demand is limited to DHW. At the end of summer the storage is fully charged. In autumn time, the user demand grows and the TES begins to discharge providing heat directly for space heating and DHW. This process continues as long as TES temperature is higher than return temperature from user. When the temperature of TES drops below the return temperature, the heat pump is switched on. Heat pump extracts heat from TES in order to completely discharge the storage and to deliver heat to user. If the heat demand is higher than the heat provided by heat pump, the back-up boilers are turned on. At the end of the winter the thermal storage is discharged and the cycle is ended.

3. Conclusions

A TRNSYS model has been realized in order to design the seasonal thermal energy storage and the solar district heating that will be realized in Florence under the European project Replicate, financed inside the program Horizon 2020 SCC1 Smart Cities and Communities.

The model describes all the components of heating plant. It has led to recognize the most relevant parameters of the system. The model proves that a water-water heat pump is a key component for this project, necessary to increase considerably the performance of the system.

A wide parametric analysis has been conducted to select the optimal size of the solar field and the storage. The solar field net aperture area has been fixed to 1000 m² reaching a production of 780 MWh/year. The TES volume of 3800 m³ is the best trade-off between energetic performance and costs. The control strategies of the heating plant have been decided based on the best performances of TES and the expected solar fraction is 44%.

The concept of solar district heating associated with a seasonal thermal storage is a promising strategy to reduce the consumption of fossil fuels in buildings. Since district heating is widely present in Europe, the integration of solar collectors with a storage could be very interesting to supply the heat demand especially during summer months when the heat request is low and heat losses are high in percentage due to recirculation.

- [1] Economidou M, Atanasiu B, Despret C, Maio J, Nolte I and Rapf O 2011 Europe's buildings under the microscope A Country-by-country review of the energy performance of buildings *Building Performance Institute Europe (BPIE)*
- [2] Xu J, Wang R Z and Li Y 2014 A review of available technologies for seasonal thermal energy storage *Solar Energy* **103** 610-638
- [3] Bauer D, Marx R, Nußbicker-Lux J, Ochs F, Heidemann, W and Müller-Steinhagen H 2010 German central solar heating plants with seasonal heat storage *Solar Energy* **84**(4) 612-623
- [4] Dalenbäck JO and Jilar T 1985 Swedish solar heating plants with seasonal storage design, performance and economy *International Journal of Ambient Energy* **6** 123–128.
- [5] Ochs F, Heidemann W and Müller-Steinhagen H 2009 Performance of large-scale seasonal thermal energy stores *Journal of Solar Energy Engineering* **131**(4) 041005
- [6] Schmidt T, Mangold D, and Müller-Steinhagen H 2003 Seasonal thermal energy storage in Germany *ISES solar world congress* **Vol. 14**
- [7] Hesaraki A, Holmberg S and Haghightat F Seasonal thermal energy storage with heat pumps and low temperatures in building projects—a comparative review 2015 *Renewable Sustainable Energy Reviews* **43** 1199–1213.
- [8] Ochs F, Heidemann W and Muller-Steinhagen H 2008 Seasonal thermal energy storage: a challenging application for geosynthetics *EuroGeo4 4th. European Geosynthetics Conference*