

Application of the lean layout planning system in a leather bags manufacturing plant and proposal of an approach to engage the company’s staff in the research of the layout solution

Alessandra Cantini*, Filippo De Carlo*, Mario Tucci *

* Department of Industrial Engineering (DIEF), University of Florence, Viale Morgagni, 40 59100 - Florence – Italy (alessandracantini@unifi.it, filippodecarlo@unifi.it, mariotucci@unifi.it)

Abstract: Since the performance of production systems are often conditioned by the factory layout, it is essential to optimize the placement of machines and facilities inside a plant. This article presents a case study of a “lean” layout planning in a new luxury leather bags manufacturing plant, in which the company decided to move the production. The aim of the new location was to redesign the factory layout in order to reduce efficiency losses. After showing how the lean techniques were implemented in factory layout planning, the article presents a new approach used to engage the company’s staff in the achievement of the layout solution. In this perspective, a two-step process was followed: first, the lean strategy was applied to get a prototype layout solution, then the novel involvement approach was used to improve, through an iterative process, the layout result. The article describes the new approach and shows how the layout solution changes with or without the involvement of skilled staff. The use of that approach does not preclude the use of other tools, simulation for instance, to validate the layout. However, this procedure can be helpful in achieving a solution that better satisfies workers, increases morale and productivity, and makes employees accept working changes more quickly.

Keywords: Layout design, lean manufacturing, lean layout planning, leather goods plant, luxury HVLV company

1. Introduction

In a manufacturing system, planning the position of the production process facilities and designing the site layout are strategic issues to maximize productivity, minimize overall production time and maximize work-in-process (WIP) turnover (Djassemi, 2007; Singh and Sharma, 2006). The layout design has a significant impact on the performance and efficiency of a production systems (Allegrì, 1984; Tompkins et al., 2010). Indeed, a well-designed and interconnected spatial arrangement can reduce up to 50% of the operating cost (Chakraborty and Das, 2020; Jiang and Nee, 2013). Optimizing the positioning of machines and departments in a production process corresponds to a typical "Facility Layout Problem (FLP)" (Drira et al., 2007). Such problem, by definition, concerns with the spatial arrangement of process equipment, departments, storage vessels and their interconnecting pipework in order to minimize the cost of transporting and handling materials, decrease throughput times and simplify the control of information and material flows (Fu and Kaku, 1997; Georgiadis et al., 1999).

It has been more than sixty years since Koopmans and Beckmann published their seminal paper on modelling the FLP (Koopmans and Beckmann, 1957). Since then, the international scientific literature on layout planning has been greatly expanded. Up to now, it partly concerns the description of approaches to solve the plant layout problem (Apple, 1978; Hassan and Hogg, 1987; Meller and Gau, 1996), partly proposes literature reviews (Hosseini-Nasab et al., 2018; Singh and Sharma, 2006), and partly describes practical case studies (Yang et al.,

2000). The multitude of scientific articles confirms the importance of the FLP both at industrial and scientific research level (Drira et al., 2007).

As stated by some authors (Yang et al., 2000), scientific methodologies for the solution of facility layout problems fall into two main categories: algorithmic approaches and procedural approaches. Algorithmic approaches are quantitative methods and usually concern operational research. In fact, they involve writing and solving an objective function in accordance with some design constraints (Peters and Yang, 1997; Yang and Peters, 1997). Procedural approaches, on the other hand, are methods based on both qualitative and quantitative inputs. They can enable the achievement of both qualitative and quantitative objectives and involve the division of the design process into several stages which are then resolved sequentially (Apple, 1978; Muther, 1973). Procedural approaches are preferred when designing the layout considering multiple objectives (Yang et al., 2000). Such approaches generate one or more layout alternatives as a result. The successful implementation of procedural approaches depends on the quality of the alternatives obtained and on the experience of the designers who must be able to select the best solution (Yang et al., 2000).

There are many procedural approaches in the literature to solve the FLP. These include the lean layout planning. In previous studies (De Carlo et al., 2013) it has been shown that lean layout planning gives excellent results when dealing with the layout design of high variety and low volume (HVLV) companies. Lean layout planning refers to the application of lean thinking in the design stage of

the factory, in particular in the layout planning stage. The goal is to reach the scientific design of the plant layout by combining lean thinking with traditional layout design approaches, and integrating the knowledge of classical optimization techniques - such as the systematic layout planning by (Muther, 1973) - with waste minimization approaches (Li, 2019).

The application of the lean thinking approach should be extended from the initial design phases of a company (“lean design”) to the operational phases of the company itself (“lean production”), in order to eliminate wastes as much as possible and truly realize the essence of lean thinking (Jones and Womack, 2016; Womack and Jones, 2017). However, “the theoretical research and application of lean production is quite mature, while the research on lean design is relatively rare” (Li, 2019). To fill this gap, the aim of this article is to show a case study of lean layout planning (which is lean design) to an HVLV company. The case study chosen is a leather goods manufacturing plant that operates in the luxury fashion field. This company has purchased a new building where it wants to transfer its current production. The change of location is used to redesign the plant layout and to reduce efficiency issues.

As said, the lean design approach can give rise to different layout alternatives. To choose the best option, it is fundamental to involve experienced company staff. Staff should be considered at all stages of the design process: from the first step of collecting information about the company, to the final step of choosing the right layout alternative (Muther, 1973). “The inputs from area experts during design process are considered to be a must towards an effective fab layout design” (Yang et al. 2000). In this perspective, besides showing the application of lean techniques in factory layout planning, the goal of the present paper is to propose a new approach to involve the company's staff in the final research of the layout solution. The approach is based on the realization of an accelerated time and space simulation, which is carried out together with the company staff and is repeated several times to verify the effectiveness of the layout solution. The procedure proposed to define the layout is as follows: at first the lean methodology is applied to arrive at a prototype solution, then the proposed approach is used to improve, through an iterative process, the final layout result. The article describes how to implement the new approach and shows how the layout solution changes with or without the involvement of experienced staff. This procedure can be helpful in achieving a solution that better satisfies employees, increases morale and productivity, and makes staff accept layout changes more quickly. It also serves to verify the effectiveness of the layout solution and check that waste is eliminated, and business performance is maximized.

The implementation of the proposed approach does not preclude the use of other tools for layout validation, such as discrete event simulation (Sa’udah et al., 2015). However, discrete event simulation, while being an excellent approach to solution validation, is time-consuming and resource-intensive and therefore moves

away from the lean perspective. Moreover, it does not use the company's know-how to select the optimal layout solution. For these reasons, it is believed that the new validation approach may be interesting when applying lean layout planning.

The remainder of the present paper is organized as follows: in section 2 the lean layout planning process and the new approach to seek the final solution are described. In section 3 the case study is presented. Finally, in section 4, a discussion regarding the results of the case study and some conclusions are provided.

2 The lean layout planning system

Lean manufacturing, also known as Toyota Production System (TPS), is a production system born in Japan, that seeks to eliminate inefficiency from all areas of a production system. (Liker, 2004). It is a multidimensional approach pioneered by Taiichi Ohno (Toyota's chief engineer), through which the operations and processes constituting a production system are divided into three kinds of activities: non-value-added activities, value-added activities and wastes (Salleh and Zain, 2012). The overall objective of the lean manufacturing is the elimination of waste and the minimization of non-value activities (De Carlo 2013).

According to the classification proposed by Taiichi Ohno (Ohno, 1988), wastes in a manufacturing company can be traced back to seven main categories, such as waiting, overproduction, rework, motion, processing, inventory and transportation. By implementing a continuous never-ending development process and using a wide variety of management practices - such as Just In Time (JIT), quality management, teamwork, industrial relations and so on (Low et al., 2015) - the lean approach typically reduces wastes and results in increased profitability, efficiency and quality of production processes (Comm and Mathaisel, 2000). The lean manufacturing approach can be used both to design and to manage a plant. When it is used to design the layout of a company, it is called “lean layout planning system”. In this case, the physical arrangement of the production machines contained in a company is defined according to the 11 principles identified by Koskela (Koskela, 1992) and pursuing “the elimination of wasteful space and the creation of a practical layout, with minimal risk to business opportunities, and associated preparation for future changes” (Salleh and Zain, 2012).

To apply the lean layout planning system, a two-steps procedure is followed (Zhenyuan et al., 2011): first, the lean strategy is applied to get a prototype layout solution (step 1). Then, a novel involvement approach is used to improve, through an iterative process, the result (step 2).

Step 1) The search for a prototype solution (step 1) is carried out by performing two sub-phases:

- a) **“Preliminary design phase”**. This phase mainly concerns the collection of key information, such as the area and the shape of the available spaces, the physical dimensions and topology of the facilities, the nature and

quantities of the manufactured parts, the production process flow, the closeness relationships between different production departments and, finally, the pains and gains of the company staff. Once the preliminary design phase has been completed, the database needed to define the new plant layout is obtained. In this phase, typically, some tools such as "value-stream map" and "relationship diagram" are used to graphically represent the collected information (Jasti et al., 2019).

- b) **“Layout design phase”**. Based on the established database, an ideal layout is built, then the desired solution is fitted into the building plan. The machines are allocated inside the available space according to the lean logics of waste minimization and considering the relationships between production departments. In this way, a prototype layout is obtained. The layout design phase can generate different layout alternatives, based on the experience and ideas of the design team. The more skilled the design team is, the more successful will be the selected prototype solution.

Step 2) Since the layout alternative chosen at the end of the step 1b is not necessarily the best possible, the solution is examined and modified to generate the optimal solution (step 2). The improvement and validation of the layout solution are achieved by performing the **“evaluation and optimization design phase”**. In this phase, the prototype layout is evaluated through qualitative and quantitative methods to verify whether it meets the company's needs (targets) and eliminates waste or not. If the solution is satisfactory, then it is suggested as the final layout solution, otherwise it is modified to reach improvements. Many evaluation methods have been proposed in the scientific literature, such as simulation, analytic hierarchy process, fuzzy evaluation method and expert scoring method (Li, 2019). However, the present paper proposes a new evaluation approach, which is more aligned with the lean philosophy. The new evaluation approach is described in the following subparagraph.

Figure 1 provides a graphical illustration of the lean layout planning system.

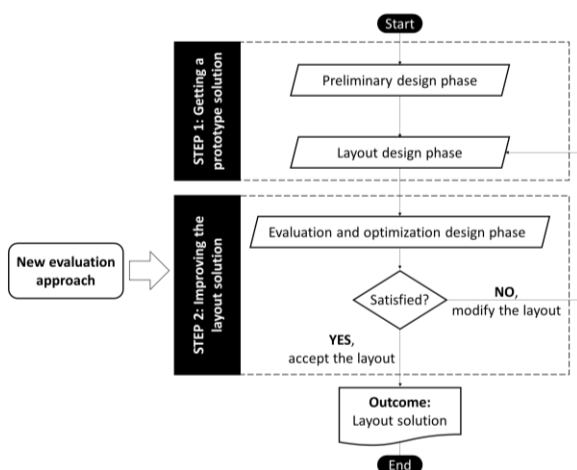

Figure 1: procedural steps of the lean layout planning system

2.1 The proposed evaluation approach

When applying the lean layout system, a plant layout is designed according to common sense principles (Koskela, 1992). Similarly to other procedural approaches (such as Systematic Layout planning - SLP), the lean layout system does not require high mathematical or computer skills, "rather it applies common-sense thoughtware in an orderly way" (Muther, 1973). For this reason, lean layout planning does not provide a unique solution, but it can give rise to different layout alternatives depending on the experience and ideas of the design team and a number of subjective decisions that are made (Bock and Hoberg, 2007). In order to select the best layout alternative - which is functional, lean and satisfying for the company's staff - it is essential to involve both lean thinking experts and the company's staff in the design process (Li 2019). Only a knowledgeable cross-functional team can identify the layout alternative that meets the technical requirements of waste elimination, while avoiding obstacles or problems for production.

The classical approach to layout planning (SLP) involves consulting staff and gathering information in the first procedural phase (Preliminary design phase, step 1a) through interviews and inspections (Ali Naqvi et al., 2016). Sometimes, staff are also engaged in the assessment of layout alternatives (step 2). But the operators' contribution is limited to the prioritisation of conflicting aspects or the choice of weight factors, to apply methods such as AHP (Yang et al., 2000) or fuzzy TOPSIS (Sharma and Singhal, 2017). In this way, it is not exploited the company know-how of those who daily face production problems, and less information is obtained than what could really be useful. Hence, it is necessary to find an effective way to draw on the knowledge of experienced workers, which hardly ever emerges during interviews. The evaluation approach here proposed fulfils this need. It is a simulation that is performed after the "layout design phase" (step 1b), aimed at evaluating and modifying the layout prototype through the involvement of company staff. With the simulation, operators can describe themselves and represent their tasks. When people describe themselves, they find it easier to present to their co-workers the issues that really affect production. The proposed evaluation approach is based on this concept: by listening to the staff of all production departments, valuable ideas are collected to improve the solution. By re-adjusting the layout plan on the basis of staff requests, it is possible to achieve a solution which is lean, capable of maximising business performance and free of all the organisational and operational problems that have emerged from the experts' know-how. Through the proposed simulation, the layout prototype deriving from step 1b is iteratively improved. The consultation of the staff results in a faster generation of a satisfactory solution and makes it more likely to be approved. A solution achieved by combining lean experts' and production experts' skills will satisfy workers, increases morale and productivity, and makes employees accept working changes quickly (Levary and Schmitt, 1986).

The following material is required to apply the proposed evaluation approach:

- A large working surface.
- A planimetry (in scale 1:50 if a single department layout is designed or 1:100 if the entire plant is considered).
- A token (game piece) in scale for each working machinery. The token can have a stylized shape (for example a rectangle), but it must faithfully reproduce the overall dimensions of the machine.
- A scaled token for each logistic transfer device (trolley, roller conveyor, etc.). The token should be differentiated according to size, ease of handling and other key features and, again, they can have a stylized shape.
- A scaled token for each shelving unit.
- A scaled token for each company worker involved in the simulation.
- Scaled tokens to represent vans and trucks dedicated to the procurement and distribution of materials.
- A big wall clock.

In the new evaluation approach, events are simulated according to accelerated times and scaled spaces. The planimetry of the plant is placed on a large working surface. Inside the planimetry (in the available space) the tokens representing the machinery and the shelves are positioned according to the prototype layout (obtained at the end of the step 1b). All the heads of the production departments are provided with a token which represent them or the materials they handle during their daily work (crates, pallets, etc.). Each participant places his token in his own production department in order to represent the work he does. A time advance unit (timestep) is established based on the structure of the work. For example, the time is scanned with 30-minute intervals and the clock is used to represent the passage of time. At this point, a typical working day is simulated by advancing the time according to the chosen cadence. As time progresses, the tokens are moved to represent the flow of materials/workers within the system. The tokens are moved starting from the area upstream of the production process and then, gradually, following the flow of materials. Although the timestep is constant, the simulation is performed at variable time. In fact, after each movement of the tokens, the simulation is temporarily stopped, and the staff is asked to tell what happens to the production. Through these interviews, the pains and gains of the workers are examined in depth (more than in the "Preliminary design phase", step 1a). During the whole process the lean layout designer verifies logistic flows, WIP, wastes, movements, throughput times, value-added times and all the parameters that need to be optimized. Whenever problems are detected, the lean expert modifies the layout prototype. Then, through an iterative process, the action is simulated again to check if the new arrangement solves the issues. Once the entire working day has been simulated, the result is a new lean layout

solution which is more satisfactory for the staff. By repeating the whole simulation several times, it is possible to find the best layout alternative.

The proposed evaluation method works properly if the precepts of "andragogy" are followed and the employees are put at ease. In fact, people collaborate when they are in a comfortable and tension-free environment. For this reason, the participation of the company chief in the simulation would be discouraged. Besides, to avoid time-pressure, the simulation should not be performed at the end of working hours, but preferably during the last hours of the working day. In addition, in the days before the simulation, the lean layout designers should be seen and known by the staff, in order to arouse curiosity and trust, and stimulate collaboration. During the simulation, the designers should be the first to make the atmosphere welcoming. In this regard, for example, they could put some snacks and drinks on the working table and run the simulation by eating the appetizers together with the staff. The right attitude helps bringing out the company's know-how and contributes to achieve the optimal solution.

3. Case study

In this article, a leather bags production company that operates in the luxury fashion field was selected to implement a case study of lean layout planning in an HVLV manufacturing plant. The company produces more than 400 models of bags and has just purchased a new rectangular shed of 8000 m² where it will transfer its leather bags production. The change of location is used to reduce efficiency losses through the re-design of the plant layout.

Step 1.a - Preliminary design phase) The sequence of activities forming the bag production process was analysed through site inspections and expert staff consultation.

Raw materials - such as leather, textile, supports, boxes for packing finished products, metal accessories, ribbons and zips - are purchased. Leather, supports and textiles are cut, then the textile pieces are returned to the warehouse, while leather and support pieces are sent to the preparation department. Here, the thickness of the leather pieces is reduced and uniformed by performing the splitting and fleshing operations. Then, leathers and supports are glued together, and the semi-finished products are crushed with a press that shears and refines the edges. Subsequently, the operations of quilting and inserting plastic tubes are carried out. These activities are not executed in all the bags. In fact, quilting is used in some bag models to achieve an aesthetic effect on the surface. Instead, the piping is carried out only on the pieces that will form the edges of the bag to reinforce the structure of the finished products. At the end of the preparation phase, stamping is carried out to print the logo of the company on the bags. The prepared semi-finished products together with textiles, ribbons, zips and metal accessories (stocked in the warehouse) are sent to the assembly department. Here, the workers manually colour the edges of the leather pieces, then they sew

linings, handles, and outer surfaces of the bags, and they assemble all the components to obtain the finished bags. Finally, the bags are transported to the packing department where they are tested (to check for manufacturing defects), packed and stored in the finished product warehouse awaiting sale. The leather production process was mapped using flow charts and ASME notation. Figure 2 summarizes the macro-phases that characterize the manufacturing process. In Figure 2, the alternation of colours (white and grey) highlights the different production departments of the plant. From the Figure 2 emerge the proximity relations between the production departments of the plant.

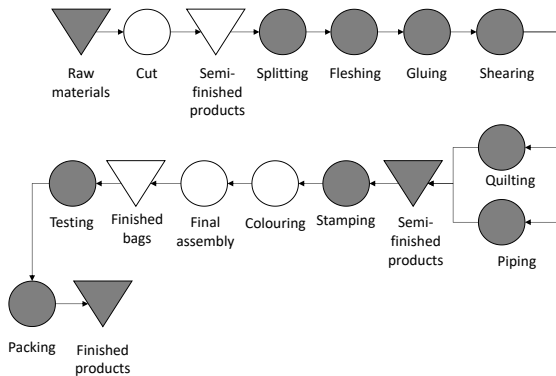

Figure 2: phases of the leather bags production process

The production machines owned by the company were surveyed, and information about their spatial dimensions, typology, and production capacity was collected. Moreover, the value stream map of the initial situation was outlined (Appendix A). Finally, the initial plant layout and its problems were studied (Figure 3).

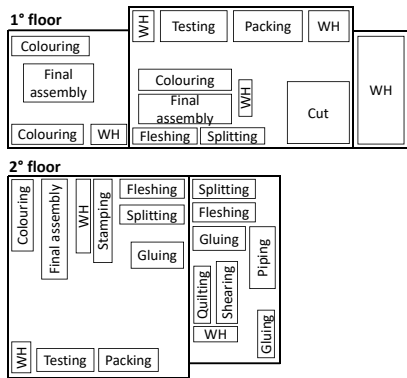

Figure 3: initial layout of the leather goods company

Initially, in the leather goods company, the production equipment was located on two floors of a building which had an area of about 5000 m². The critical issues that could be solved by redesigning the layout were as follows:

- The time spent by the items in the warehouse was too long.
- The distance between workstations was excessive, and this caused high material moving times.

- There was no free space to add new machinery and increase production in the cutting and preparation departments (HVLV plant was not flexible to demand variations).
- The material flows were not linear. In fact, the same product was moved several times (in a messy way) from one production department to another. This made it difficult to carry out visual inspections on the production progress of each bag model. Moreover, within each department the machines were arranged without criteria, so the production process was decelerated by the presence of bottlenecks.

Step 1.b - Layout design phase)

Applying the principles of lean manufacturing, a prototype layout solution was obtained (Figure 4).

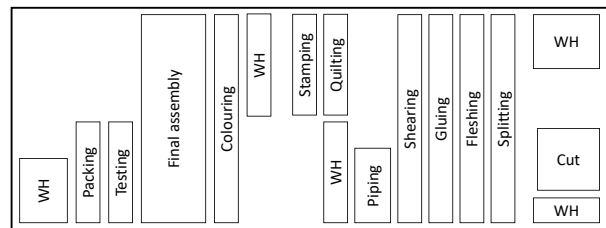

Figure 4: prototype lean layout obtained at the end of the “layout design phase” (step 1b)

The prototype was designed considering three aspects: the company produces according to PULL logic, the volume-variety diagram for the analysed company suggests a cellular layout (De Carlo et al., 2013) and, finally, in a lean perspective the flow of materials should be as linear as possible.

In the prototype layout the production departments were arranged according to work cells and respecting the proximity relationships. This reduces the distances that staff and logistics devices must travel to move products from one department to the following one. The machines were arranged in order to optimize their production capacity and reduce bottlenecks and throughput times. In fact, machines with the same production capacity were disposed in parallel, while the remaining were arranged in series (positioning first the fastest machines and then the slowest ones). The departments were arranged to produce a linear and tense flow of materials, so as to obtain a WIP that moves in an orderly manner in a single direction (from the entrance to the exit), without ever going back. This allows to control the production progress at any time and to reduce the time the items spent in the warehouse. Finally, in the cutting and preparation departments, free space was left to give the company the opportunity to buy new equipment and expand production.

Step 2 – Modelling and simulation phase)

Applying the evaluation approach described in Section 2.1, the prototype layout was readjusted by considering the know-how of the company staff. Repeating the simulation several times, the final layout was obtained

(Figure 5). Appendix A shows the value stream map for the final layout.

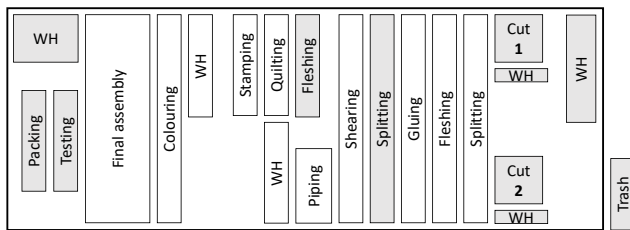

Figure 5: final lean layout obtained at the end of the “modelling and simulation phase” (step 2)

The staff interview generated some ideas for further improvements, which are coloured grey in Figure 5. A trash storage department was added. The leather manufacturing process, in fact, generates a lot of scraps. The cutting department was divided into two zones: one for automatic cutting machines and one for manual cutting machines. This was done to separate the flows of precious and cheap materials, allowing a better production control and reducing bottlenecks. A splitting and a fleshing department were added downstream of the gluing area. In fact, the staff reported that sometimes the semi-finished products must be refined after the gluing phase. Finally, the testing and packing departments were moved closer to the factory exit. In fact, the bags are precious and expensive objects and the staff said that, sometimes, customers want to personally check the quality of the finished products. Therefore, these departments should be located in areas that are easily accessible from the outside.

4. Discussion and conclusions

In the present paper, the application of the lean layout system to a case study of an HVLV company working in the luxury leather goods sector is shown. According to the typical procedure of the lean layout system, first information about the company was collected, then a prototype layout solution was designed and, finally, the solution was iteratively improved through an evaluation approach. The article illustrates a new approach to evaluate and improve the prototype layout by engaging the company's staff in the achievement of the final solution. The proposed methodology is a viable way to solve real-world layout design problems in HVLV companies. In fact, the presented lean layout planning procedure successfully solved the case study: compared to the initial layout, the final layout reduces the problems associated with bottlenecks, lack of free space, difficulty in carrying out quality checks, high storage times and long distances to move objects. Appendix A confirms how waste and non-value-added operations are reduced from the initial layout to the final one (there is a decrease in total production time of almost 10 days).

Moreover, the comparison between the prototype layout solution and the final solution demonstrate the importance of consulting the staff to take advantage of their know-how and generate new ideas to improve the result. In fact, both solutions (with or without staff involvement) are good because they reduce waste and solve the main production issues. However, the second

alternative (final layout) is preferable because it also solves problems related to garbage, finishing operations and tests carried out by external customers. The evaluation approach proposed in this paper is useful because the consultation of the skilled staff allows to improve the prototype layout, in order to obtain a final layout that is as satisfactory as possible for those who daily work in the production departments. In such a way, it is possible to generate a lean layout solution that increases staff morale and make them accept working changes.

Further advantages of the proposed lean layout planning approach are as follows. It allows to iteratively improve the layout solution and to choose the best alternative. Its application is quick and simple, and it can be used in any type of company. Finally, it can generate more or less detailed layouts according to the company's needs. In fact, during the simulation the tokens representing machinery, shelves and other production equipment are moved. At the end of the simulation, hence, the final layout can be represented either in a macroscopic way, illustrating the disposition of the departments (as shown in Figure 5), or in a detailed way representing the position of each production machine.

When using the approach, it is essential that the lean layout designers take a friendly attitude and put the staff at ease. In fact, a wrong behaviour of the designers and an oppressive atmosphere prevents workers from expressing their know-how and ideas. As a result, the entire work and the overall result are compromised.

References

- Ali Naqvi, S.A., Fahad, M., Atir, M., Zubair, M., Shehzad, M.M., 2016. Productivity improvement of a manufacturing facility using systematic layout planning. *Cogent Engineering* 3, 1207296.
- Allegri, T.H.S., 1984. *Materials handling*.
- Apple, J.M., 1978. *Plant layout and material handling*, 3rd ed. John Wiley & Sons Inc.
- Bock, S., Hoberg, K., 2007. Detailed layout planning for irregularly-shaped machines with transportation path design. *European Journal of Operational Research* 177, 693–718.
- Chakraborty, B., Das, S., 2020. Development of Plant Layout for Improving Organizational Effectiveness by Hybridizing GT, TOPSIS and SLP, in: Venkata Rao, R., Taler, J. (Eds.), *Advanced Engineering Optimization Through Intelligent Techniques, Advances in Intelligent Systems and Computing*. Springer, Singapore, pp. 515–525. https://doi.org/10.1007/978-981-13-8196-6_45
- Comm, C.L., Mathaisel, D.F., 2000. A paradigm for benchmarking lean initiatives for quality improvement. *Benchmarking: An International Journal*.
- De Carlo, F., Arleo, M.A., Borgia, O., Tucci, M., 2013. Layout design for a low capacity manufacturing line: a case study. *International Journal of Engineering Business Management* 5, 5–35.

- Djassemi, M., 2007. Improving factory layout under a mixed floor and overhead material handling condition. *Journal of Manufacturing Technology Management* 18, 281–291. <https://doi.org/10.1108/17410380710730611>
- Drira, A., Pierreval, H., Hajri-Gabouj, S., 2007. Facility layout problems: A survey. *Annual Reviews in Control* 31, 255–267. <https://doi.org/10.1016/j.arcontrol.2007.04.001>
- Fu, M.C., Kaku, B.K., 1997. Minimizing work-in-process and material handling in the facilities layout problem. *IIE transactions* 29, 29–36.
- Georgiadis, M.C., Schilling, G., Rotstein, G.E., Macchietto, S., 1999. A general mathematical programming approach for process plant layout. *Computers & Chemical Engineering* 23, 823–840. [https://doi.org/10.1016/S0098-1354\(99\)00005-8](https://doi.org/10.1016/S0098-1354(99)00005-8)
- Hassan, M.M., Hogg, G.L., 1987. A review of graph theory application to the facilities layout problem. *Omega* 15, 291–300.
- Hosseini-Nasab, H., Fereidouni, S., Ghomi, S.M.T.F., Fakhrzad, M.B., 2018. Classification of facility layout problems: a review study. *The International Journal of Advanced Manufacturing Technology* 94, 957–977.
- Jasti, N.V.K., Kota, S., Sangwan, K.S., 2019. An application of value stream mapping in auto-ancillary industry: a case study. *The TQM Journal*.
- Jiang, S., Nee, A.Y.C., 2013. A novel facility layout planning and optimization methodology. *CIRP Annals* 62, 483–486. <https://doi.org/10.1016/j.cirp.2013.03.133>
- Jones, D.T., Womack, J.P., 2016. The evolution of lean thinking and practice. *The Routledge companion to lean management* 8, 3.
- Koopmans, T.C., Beckmann, M., 1957. Assignment problems and the location of economic activities. *Econometrica: journal of the Econometric Society* 25(1), 53–76.
- Koskela, L., 1992. Application of the new production philosophy to construction. Stanford university Stanford.
- Levary, R.R., Schmitt, A., 1986. Planning facilities layout in clinical laboratories using a group decision making process. *Computers & industrial engineering* 10, 179–191.
- Li, Y., 2019. Application of lean design in the planning layout of slab plant, in: *IOP Conference Series: Materials Science and Engineering*. IOP Publishing, p. 022037.
- Liker, J.K., 2004. *The Toyota Way: 14 Management Principles from the World's Greatest Manufacturer* McGraw-Hill Education.
- Low, S.P., Gao, S., Tiong, K.L., 2015. Applying lean production principles to facilities design of ramp-up factories. *Facilities*.
- Meller, R.D., Gau, K.-Y., 1996. The facility layout problem: recent and emerging trends and perspectives. *Journal of manufacturing systems* 15, 351–366.
- Muther, R., 1973. *Systematic Layout Planning*/by Richard Muther.
- Ohno, T., 1988. *Toyota production system: beyond large-scale production*. crc Press.
- Peters, B.A., Yang, T., 1997. Integrated facility layout and material handling system design in semiconductor fabrication facilities. *IEEE Transactions on Semiconductor manufacturing* 10, 360–369.
- Salleh, M., Zain, M.Z.M., 2012. The study of lean layout in an automotive parts manufacturer, in: *Applied Mechanics and Materials*. Trans Tech Publ, pp. 3947–3951.
- Sa'udah, N., Amit, N., Ali, M.N., 2015. Facility layout for SME food industry via value stream mapping and simulation. *Procedia Economics and Finance* 31, 797–802.
- Sharma, P., Singhal, S., 2017. Implementation of fuzzy TOPSIS methodology in selection of procedural approach for facility layout planning. *The International Journal of Advanced Manufacturing Technology* 88, 1485–1493.
- Singh, S.P., Sharma, R.R.K., 2006. A review of different approaches to the facility layout problems. *The International Journal of Advanced Manufacturing Technology* 425–433.
- Tompkins, J.A., White, J.A., Bozer, Y.A., Tanchoco, J.M.A., 2010. *Facilities Planning*, 4th ed. Wiley.
- Womack, J.P., Jones, D.T., 2017. *Lean Thinking. Come creare valore e bandire gli sprechi*. goWare & Guerini Next.
- Yang, T., Peters, B.A., 1997. A spine layout design method for semiconductor fabrication facilities containing automated material-handling systems. *International Journal of Operations & Production Management*.
- Yang, T., Su, C.-T., Hsu, Y.-R., 2000. Systematic layout planning: a study on semiconductor wafer fabrication facilities. *International Journal of Operations & Production Management*.
- Zhenyuan, J., Xiaohong, L.U., Wei, W., Defeng, J., Lijun, W., 2011. Design and implementation of lean facility layout system of a production line. *International Journal of Industrial Engineering* 18.

Appendix A. VALUE STREAM MAPS

Appendix A shows the following figures:

- The initial value stream map of the leather bags manufacturing plant (Figure 6).
- The value stream map obtained after changing the location of the plant and arranging the equipment according to the final layout (Figure 7).

The value stream maps were performed to better understand the waste reduction achieved by applying the proposed lean layout planning approach. The maps summarize the average duration of all the operations carried out in the production process of a bag. For the

construction of the maps, it was considered the most produced bag model of the plant under analysis. Besides, both value-added operations (processing times) and non-value-added operations (transporting and awaiting times) were considered. The numerical results used to build the maps were partly measured manually (with a chronometer), and partly derived from the available databases. The measure units used to quantify times were seconds (s) or days (d).

In maps, for operations that were performed at once, the duration was written above the timeline. On the other hand, for operations that were executed twice, the time of the first operation was written above the time line, while the time needed to bring the piece back to the machine and execute the second operation was written below the line. In the case of non-value-added times, the total duration was indicated as the sum of two times: the time needed to transport the semi-finished products from one department to the next, and the time needed to wait for the next operation to be carried out. Sometimes, in fact, an operation is performed only if the entire batch of bags has completed the previous one.

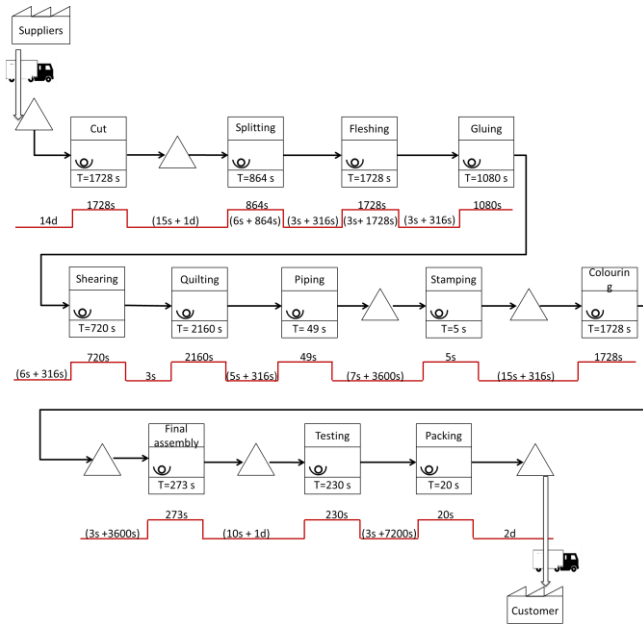

Figure 6: value stream map related to the initial layout

Figure 6 shows the value stream map related to the initial layout of the plant. Figure 6 shows the waste that characterizes the initial situation of the company. Transporting and awaiting times are very high and this depends on the fact that the company is in a two-floor building and it is necessary to move several times from one floor to another, but above all it depends on the fact that machines are arranged in a messy way and two consecutive production departments are not always placed close to each other. Figure 6 also shows the waste of time caused by the repetition of certain processes (such as splitting or fleshing) and linked to a non-linear flow of materials.

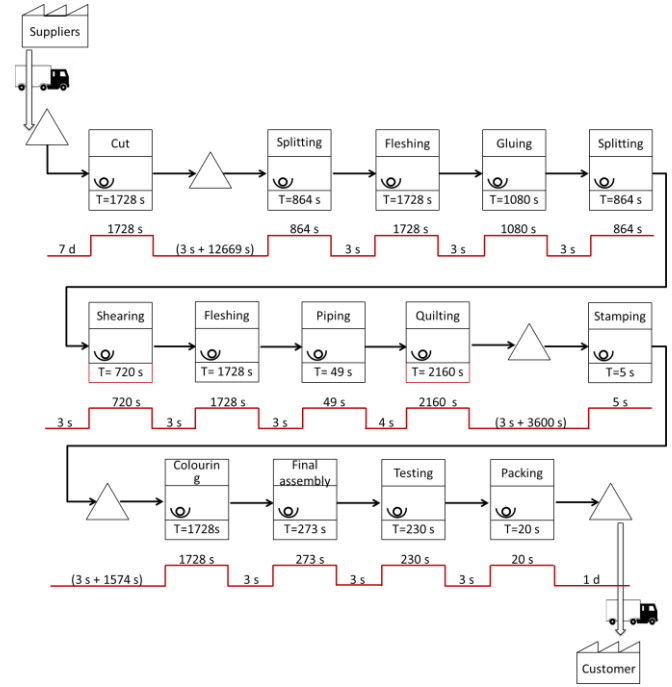

Figure 7: value stream map related to the final layout

Figure 7 shows the benefits in terms of time and waste reduction achieved by using the proposed lean layout planning approach and adopting the final layout. The non-value-added times are reduced: there is a reduction in total transport time of 42 seconds, and a reduction in total waiting time for items in the warehouse of almost 10 days (862.137 seconds). Finally, a linear flow of materials is achieved, thus avoiding wastes such as moving semi-finished products from one workstation to the previous one or moving workers and transport equipment between distant production departments.

The comparison between Figure 6 and Figure 7 confirms that the final layout is advantageous compared to the initial one and, while respecting all the production constraints, it reduces the overall production time (-862.179 seconds) and increases the production performance of the plant.