



(51) International Patent Classification:

H01P 3/16 (2006.01) *G02B 6/032* (2006.01)
G02B 6/036 (2006.01)

(21) International Application Number:

PCT/EP2019/084547

(22) International Filing Date:

11 December 2019 (11.12.2019)

(25) Filing Language:

English

(26) Publication Language:

English

(30) Priority Data:

01598/18 21 December 2018 (21.12.2018) CH

(71) Applicant: **HUBER+SUHNER AG** [CH/CH];
Degersheimerstrasse 14, 9100 Herisau (CH).

(72) Inventors: **WAGNER, Martin**; Hafenstrasse 13b, 9323
Steinach (CH). **CROCE, Andrea**; via Liguria 23, 20025
Legnano (IT). **HÜGEL, Ulf**; Eggweg 8, 9100 Herisau (CH).

(74) Agent: **RENTSCH PARTNER AG**; Bellerivestrasse 203,
Postfach, 8034 Zürich (CH).

(81) Designated States (unless otherwise indicated, for every

kind of national protection available): AE, AG, AL, AM, AO, AT, AU, AZ, BA, BB, BG, BH, BN, BR, BW, BY, BZ, CA, CH, CL, CN, CO, CR, CU, CZ, DE, DJ, DK, DM, DO, DZ, EC, EE, EG, ES, FI, GB, GD, GE, GH, GM, GT, HN, HR, HU, ID, IL, IN, IR, IS, JO, JP, KE, KG, KH, KN, KP, KR, KW, KZ, LA, LC, LK, LR, LS, LU, LY, MA, MD, ME, MG, MK, MN, MW, MX, MY, MZ, NA, NG, NI, NO, NZ, OM, PA, PE, PG, PH, PL, PT, QA, RO, RS, RU, RW, SA, SC, SD, SE, SG, SK, SL, SM, ST, SV, SY, TH, TJ, TM, TN, TR, TT, TZ, UA, UG, US, UZ, VC, VN, ZA, ZM, ZW.

(84) Designated States (unless otherwise indicated, for every

kind of regional protection available): ARIPO (BW, GH, GM, KE, LR, LS, MW, MZ, NA, RW, SD, SL, ST, SZ, TZ, UG, ZM, ZW), Eurasian (AM, AZ, BY, KG, KZ, RU, TJ, TM), European (AL, AT, BE, BG, CH, CY, CZ, DE, DK, EE, ES, FI, FR, GB, GR, HR, HU, IE, IS, IT, LT, LU, LV, MC, MK, MT, NL, NO, PL, PT, RO, RS, SE, SI, SK, SM, TR), OAPI (BF, BJ, CF, CG, CI, CM, GA, GN, GQ, GW, KM, ML, MR, NE, SN, TD, TG).

(54) Title: DIELECTRIC WAVEGUIDE CABLE

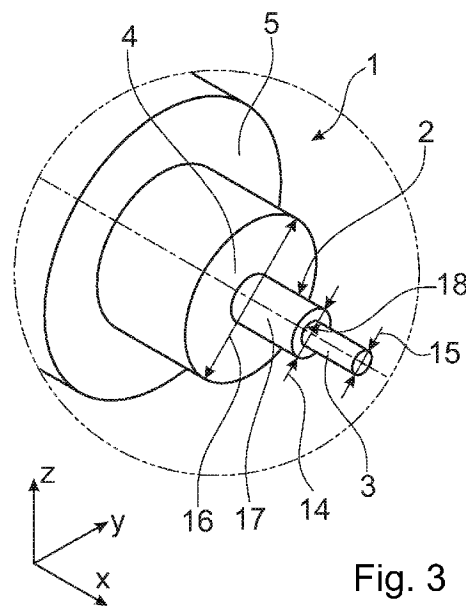
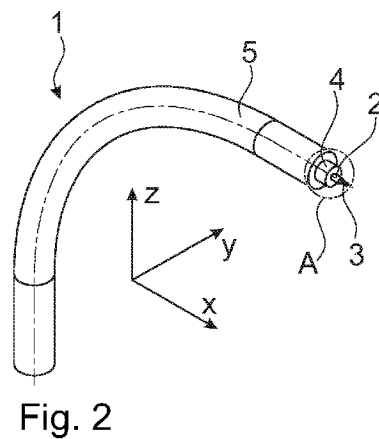

(57) Abstract: The invention is directed to a dielectric wave guide cable (1) comprising a tubular core (2) made from a low loss material having a certain permittivity. The tubular core (2) is encompassed by a cladding (3) having, compared to the tubular core (2), a lower permittivity. The tubular core (2) may be coated on the inside by a coating (3) having a higher permittivity. The cladding (3) may be encompassed by a jacket (4).



Published:

— *with international search report (Art. 21(3))*

DIELECTRIC WAVEGUIDE CABLE

FIELD OF THE INVENTION

The present invention relates to dielectric waveguide cable for transmitting of electromagnetic waves for high speed data transmission between two devices in the
5 range of gigahertz.

BACKGROUND OF THE INVENTION

EP3306740A1 (WO18068914A1), first published in April 2018 on behalf of Rosenberger Hochfrequenztechnik GmbH, relates to a dielectric waveguide cable. The dielectric waveguide cable is having a first dielectric core of tubular or solid
10 shape and a second dielectric in which air is included. The first dielectric is designed for confinement of the transmitted electromagnetic waves and has a first permittivity. The second dielectric at least partially surrounds the first dielectric and is designed for spatially limiting the electromagnetic waves. It has a second permittivity which is lower than the first permittivity. The invention further relates to a trans-
15 mission method for a signal. The general principle is known from **US4463329** which also describes a dielectric waveguide with a solid dielectric core surrounded by a dielectric containing air.

EP3389133A1 (WO18188838A1) was first published in October 2018 in the name of Rosenberger Hochfrequenztechnik GmbH. It relates to a dielectric waveguide cable, in particular for use in the automotive sector. The dielectric waveguide cable is having a first dielectric and a second dielectric and a separating layer which is formed between the first dielectric and the second dielectric.

US4463329A was first published in July 1984 in the name of Junkosha Co. Ltd. It describes a dielectric waveguide in cable form fabricated from polytetrafluoroethylene. The cable is a composite of partially sintered PTFE and sintered and unsintered expanded PTFE arranged in such a fashion that the specific gravity of cable decreases from the core to the outer surface. The dielectric waveguide either uses step-varying or continuously-varying dielectric constant PTFE materials.

US2017170539A1 was first published in June 2017 in the name of TE Connectivity Ltd. It relates to a dielectric waveguide for propagating electromagnetic signals. The waveguide includes a cladding and an electrically conductive shield. The cladding has a body composed of a first dielectric material. The body defines a core region that is filled with a second dielectric material different than the first dielectric material. The cladding further includes at least two ribs extending from an outer surface of the body to distal ends. The shield engages the distal ends of the ribs and peripherally surrounds the cladding such that air gaps are defined radially between the outer surface of the body and an interior surface of the shield.

WO2015180850A1 (US2017077581A) was first published in December 2015 in the name of Spinner GmbH. The publication relates to a flexible and twistable

terahertz waveguide assembly which has a flexible waveguide with waveguide flange connectors at its ends. The flexible waveguide comprises a segmented tube of a plurality of tube segments which are connected to each other. The tube encloses a dielectric waveguide which is held by means of threads at the center of the tube. The individual segments are tiltable and/or pivotable against each other, allowing bending and twisting of the waveguide cable.

WO2018063342A1 was first published in April 2018 in the name of Aleksandar Aleksov and relates to a method of making a waveguide comprising extruding a first dielectric material as a hollow waveguide core comprising air. An outer layer is coextruded with the waveguide core, wherein the outer layer is arranged around the waveguide core.

US4216449 was first published in July 1978 on behalf of BBC Brown Boveri and Cie. It relates to a waveguide for the transmission of electromagnetic energy which has a low attenuation even with a small line cross-section. The waveguide comprises an electromagnetically shielded hollow cylinder consisting of a substance having a low permittivity, wherein in the interior a dielectric wire of a substance having a high permittivity is disposed. An E_{0m} -wave ($m = 1, 2, 3, \dots$, circular H field) is excited in the dielectric wire and the dimensioning of the dielectric wire is such (depending on the permittivities of the two substances and the particular operating frequency) that a TEM wave develops at least substantially in the space in the dielectric hollow cylinder. In the simplest case, the electromagnetic shield can consist

of a metal tube and the dielectric hollow cylinder can consist primarily of air. Furthermore, the E_{0m} wave excited in the dielectric wire is preferably the E₀₁ wave (TM₀₁ mode).

EP0304141 (US4875026A) was first published in February 1989 in the name of
5 WL Gore and Associates Ing. It relates to a dielectric waveguide for the transmission
of electromagnetic waves. The dielectric waveguide comprises a core of polytetra-
fluoroethylene (PTFE), one or more layers of PTFE cladding overwrapped around
the core, a mode suppression layer of an electromagnetically lossy material cover-
ing the cladding and an electromagnetic shielding layer covering the mode sup-
10 pression layer. The mode suppression layer is preferably a tape of carbon-filled
PTFE. Another electromagnetically lossy material layer may be placed around the
shield to absorb any extraneous energy.

SUMMARY OF THE INVENTION

Continuously increasing demand for more economical solutions offering high
15 speed data transmission between devices interconnected by network cables has
pushed engineers searching for alternatives to expensive glass optical fiber (FO)
transmission. Usually for shorter cable length, copper based cables were the pri-
mary choice. However, with data rates moving toward 100 Gbit/s and beyond, the
complexity, power consumption and cost of such systems approaches the fiber op-
20 tic level.

Progress in semiconductor technologies, especially in miniaturization of silicon CMOS (Complementary Metal-Oxide-Semiconductor), nowadays allow to build fully integrated transceivers with signal transmission in the range of wave lengths in the range of millimeters (mm) and beyond. At these frequencies it becomes of interest to use dielectric waveguide cables confining and thereby guiding the radiated electromagnetic signal by a higher permittivity compared to e.g. the surrounding air. The field energy distribution in and around such waveguides can be described using Bessel-Functions showing a field energy decay over the radius outside of the core. Unfortunately, such cable transmission gets significantly disturbed when the surrounding air disappears, respectively is distorted, e.g. by getting in contact with any solid material. To avoid this, it would be possible to use a core material with higher permittivity surrounded by a larger outer cladding layer with lower permittivity, so the main field portion will propagate in the core and the field energy in the cladding layer material will decrease with the diameter ending ideally with hardly zero percentage of the transmitted field energy outside of the cladding.

To be sure that the desired propagation is not disturbed by surrounding materials or fields the diameter of the cladding layer material has to be designed sufficiently large. A typical single mode optical fiber (SMF) for operation at 1550 nm wavelength typically has a core of t 9 μm surrounded by a cladding having a diameter in of about 125 μm having a lower permittivity. In the mm-wave range (e.g. 130 GHz equates 2.3 mm) the wavelength are about factor 1000 larger compared to the fiber optical wavelength (e.g. 1550 nm), so it is desired to have a large difference between the dielectric constant of the core and the surrounding material as in this

case the field will decay much faster and smaller cables can be realized. Furthermore, field confinement in the core improves the ability of the cable to guide the electromagnetic wave under bending conditions of the cable. Another approach to reduce the cable diameter and still avoiding relevant field energy portion of the transmitted signal outside of the cable is to use an outer electrically conductive shielding layer. If this electrically conductive shielding layer is metallic having a good conductivity other undesired higher waveguide modes can propagate, causing serious multi-mode interference distortion of the signal. Therefore, the better choice would be a shielding layer with poor conductivity suppressing the undesired waveguide modes by resistive attenuation. But the more field energy from the desired mode reaches the outer dissipation layer the more energy is withdrawn from the signal transmission resulting in an increased loss.

Bending of dielectric waveguide cables is always a critical subject, because the propagating electromagnetic field carrying the signal tends to propagate on a straight line, some electromagnetic field energy will exiting the cable in the bend and so leading to high losses. Acceptable bending radius of dielectric waveguide cables is tightly related to the largest wavelength of the transmitted signal (e.g. within a transmission band of 110 GHz to 140 GHz the free space wavelength of the lower band edge of 110 GHz is 2.7 mm). In the literature (e.g. A Multi-Gigabit CPFSK Polymer Microwave Fiber Communication Link in 40 nm CMOS Niels Van Thienen, Student Member, IEEE, Wouter Volkaerts, Member, IEEE, and Patrick Reynaert, Senior Member, IEEE - IEEE JOURNAL OF SOLID-STATE CIRCUITS, VOL. 51, NO. 8, AUGUST 2016) it is shown that by restricting a curvature radius to at least 15 to 20 times the wavelength, it is possible to avoid excessive leakage of the

electromagnetic field. Thin cables with good guiding properties can achieve better results, up to 7.5 to 10 wavelength bending radii, allowing for example in the 110-140 GHz band 2 cm to 3 cm radii instead of 4 cm to 6 cm radii. This may be relevant when the available space is critical and it becomes therefore relevant to bend the
5 cable on a smaller radius.

Compared to fiber optic cable with attenuation values of about 1 dB/km, attenuation at mm-waves is a serious issue. Depending on the dissipation factor of the materials guiding relevant electromagnetic energy portion of the transmitting signal, it typically varies between 2 dB/m and 5 dB/m and may even reach more than 50
10 dB/m. The latter values occur when trying to reduce cable diameter by higher electromagnetic field confinement using higher permittivity core material. Polymer materials show a disproportional increase of the dissipation factor with increasing permittivity. The second critical parameter (at higher data rates even the most critical) for mm-wave and sub-mm-wave DWG transmission is the signal dispersion gener-
15 ated from material dispersion and waveguide dispersion. Compared thereto material dispersion for low loss polymer material is typically negligible.

One object of the invention is to design a dielectric waveguide cable for the transmission of sub-mm-wave lengths, e.g. in the range of 110 to 140 GHz, offering the possibility of small outer diameters in the range of 4 mm or less in combination
20 of comparable low attenuation (e.g. less than 5 dB/m) in the full band and comparable low dispersion (e.g. group delay variation less than 4 pico sec/m)

In the literature the research work primarily focuses on polymer waveguide with basically two types of cores, namely solid cores or hollow tube cores build from polymer materials with higher permittivity surrounded by at least one outer cladding layer made from material having a thereto compared lower permittivity. Both core types can have a rectangular cross section which would better support linear polarization transmission, or with a round cross section which provides good results for circular polarized transmission.

Unless otherwise stated, the term permittivity as applied herein normally means the absolute permittivity, i.e. the measure of capacitance that is encountered when forming an electric field in a particular medium. More specifically, permittivity describes the amount of charge needed to generate one unit of electric flux in a particular medium. Accordingly, a charge will yield more electric flux in a medium with low permittivity than in a medium with high permittivity. Permittivity is the measure of a material's ability to store an electric field in the polarization of the medium. The lowest possible permittivity is that of a vacuum. The permittivity of a dielectric medium is often represented by the ratio of its absolute permittivity to the absolute permittivity of vacuum. This dimensionless quantity is called the medium's relative permittivity, sometimes also called "permittivity". Relative permittivity is also commonly referred to as the dielectric constant, a term which has been deprecated in physics and engineering as well as in chemistry.

A tubular core as described hereinafter in more detail offers the advantage of significant lower loss compare to dielectric waveguides as known from the prior art, because a lower portion of the electromagnetic field energy is traveling in the

higher permittivity polymer material with high dissipation factor. The disadvantage of a hollow tube is usually significant higher waveguide dispersion and significant less field confinement increasing the needed outer diameter of the cable.

Inspired by the work at terahertz frequencies where the field is confined by electronic bandgap structure realized cylindrically periodic structures of altering high and low permittivity material (EBG waveguide) one aspect of the present invention is to provide a band gap structure with significant smaller dimensions to confine the field with only a comparably small field portion propagating in the high permittivity (and high dissipation factor) polymer.

One embodiment of a dielectric wave guide cable comprises a tubular core made from a low loss material, such as e.g. Polytetrafluoroethylene (PTFE), Polyethylene (PE), Polystyrene (PS), or the like, encompassed by a cladding having compared to the tubular core a lower permittivity. Good results can be achieved by foamed PE and/or expanded PTFE or e.g. a profile with air channels as proposed in

US4216449.

In the subsequent table a selection of low loss (polymer) materials is provided in an exemplary manner, including their typical values for permittivity and dissipation factor. These materials and other having similar properties play an important role as will become apparent in more detail hereinafter.

Low loss (polymer) materials	Permittivity	Dissipation factor
Foamed Polyethylene (PE foam)	1.4	10 E-05
Expanded Polytetrafluoroethylene (E-PTFE)	1.6	12 E-05
Polytetrafluoroethylene (PTFE)	2.1	15 E-05
Polyethylene (PE)	2.3	15 E-05
Polypropylene (PP)	2.2	35 E-05
Polystyrene (PS)	2.5	50 E-05
Polyetheretherketone (PEEK)	3.2	200 E-05
Polyimide (PI)	3.5	360 E-05
Liquid Cristal Polymer (LCP)	3.1	410 E-05
Polyphenylene Sulfide (PPS)	4.2	830 E-05

To achieve the bandgap structure for more field confinement inside the tube, an inner layer with higher permittivity compared to the tubular core can be applied on the inside wall of the tubular core. Depending on the permittivity of this inner material the tube boring and layer dimensions the field confinement can be controlled

as described hereinafter. An optimization process for the design of a cable according to the invention may typically comprise the following method steps:

- (a) Define outer diameter $D_{2\ outer}$ of the tubular core (starting point for optimization): To avoid negative signal degradation by multi-mode operation the cutoff frequency of the first higher mode (TM01) should be located close to the upper frequency of the operating band. The outer diameter can be calculated according to the following formula (+/- 10%):

$$D_{2\ outer}[mm] \approx \frac{1000}{f_{upper}[GHz] * \sqrt{\epsilon_{r\ eff.}}}$$

- (b) Define inner diameter $d_{2\ inner}$ of the tubular core (starting point for optimization): To provide good guidance of the wave even at the lower frequency of the operation band the radius the inner diameter of the tubular core should be small compared to the wavelength. The inner diameter can be calculated according to the following formula (+/- 10%):

$$d_{2\ inner}[mm] \approx \frac{240}{f_{lower}[GHz] * \sqrt{\epsilon_{r\ 3\ high.}}}$$

- (c) Define layer thickness of thin high permittivity layer δ_3 (starting point for optimization): This layer should be thin, not to carry too much field energy. The thickness of the layer can be calculated by the following formula (+/- 10%):

$$\delta_3[\text{mm}] \approx \frac{60}{f_{\text{lower}}[\text{GHz}] * \sqrt{\epsilon_{r3 \text{ high}}}}$$

- (d) Group delay optimization: Chose the cladding diameter R3 ideally 2*R2 (smaller diameter are possible but more field will leak out of the cable). Run parameter optimization to flatten group delay variation in an electro-
- 5 magnetic field solver.

Therefore, the outer diameter of the cable can be adjusted to the transmission properties of the application needed. Surprisingly simulations show that this type of waveguide provide a significant better guidance of the wave allowing tighter bending radius of the cable. With a cable design according to the invention a com-

10 parable high dissipation factor of a high permittivity thin inside layer becomes almost irrelevant for the attenuation allowing to shrink cable dimensions without the penalty of significant attenuation increase caused by the dissipation factor increase in order of magnitudes above the values from PTFE, PE etc. Surprisingly it was de-

15 tected, that with balancing the thickness of the inner layer and the thickness of the hollow low loss dielectric tube the waveguide dispersion can be reduced and thereby the group delay variation can be flattened over a large bandwidth: In the range of e.g. 110 GHz to 140 GHz the delay can be kept below 4 pico sec/m compared to about 60 pico sec/m for a conventional solid core design or about 80 pico sec/m for a conventional hollow waveguide design.

In difference to the prior art, preferred variations of the invention are based on a tubular core instead of full cross-section of low density PTFE to guide electromagnetic waves, resulting in ascending and descending dielectric constant values (from the core outwards).

- 5 Use of thin high permittivity layer for field confinement on the inside of the tubular core. The thinner the layer on the inside of the tubular core is, the less the behavior of the cable is depending on the dissipation factor of said material, since most of the field is confined and propagating in the tubular core, while only a small portion of the field is propagating in the high dissipation factor layer. Thus allowing to
- 10 choose freely the material concentrating on needed permittivity without having to worry about the high dissipation factor which is mostly not specified/known in this frequency range, where measurement are expensive, unprecise and unreliable.

Cables known from the prior art typically have diameters in the range of 9 to 15 millimeters. In difference to them, improved cables according to the invention offer

15 diameters in the range of 3.5 to 5 mm keeping losses within acceptable values, depending on the field of application e.g. 3-8 dB/m. In combination with the lower bending radius it becomes possible to use a dielectric wave guide cable according to the invention in environments where cable volume is a critical factor. The minimum bending radius of the cable will be reduced in a similar factor as the cable

20 dimension shrinks. As group-delay variation may become a limiting factor for the achievable transmission length, the cable design according to the invention may significantly improve the group delay variation by e.g. 20% bandwidth at e.g. 100

GHz from several hundred pico sec per meter to values below two pico sec per meter cable length.

Depending on the field of application, a foamed cladding material can be used in on the inside of the cable instead of air or other gases, e.g. an extruded profile
5 and/or a PTFE foil wrapped as proposed in **EP0304141**. Alternatively or in addition, a conductive jacket may help to hinder field strength leaking out of the cable. Alternatively or in addition, a jacket made from a resistive material, such as e.g. carbon filled polymer, etc. may be used as jacket material.

The number of layers altering higher and lower permittivity may be further in-
10 creased, possibly resulting in even better performance (increased bandwidth, more field confinement, flatter group delay). A gradually permittivity variation instead of discrete steps may work as well.

Instead of a circular cross section, any other form may be applied (e.g. rectangular, polygonal, etc.). The high permittivity layer may e.g. be realized by co-extrusion of
15 a polymer material with the tubular core, by a coating process or any other state of the art inner layer building methods. Applicable materials could be e.g. glass or ceramic as wrapped foil, woven material or grinded powder with or without thermoplastic, duroplastic, pasty fillers or liquids.

In a preferred variation, a dielectric wave guide cable according to the invention
20 normally comprises a tubular core made from a first material having a first permittivity. The tubular core is directly or indirectly encompassed by a cladding having,

compared to the tubular core, a second permittivity which is lower than the first permittivity. In addition, the tubular core comprises on the inside an inner layer having a third permittivity which is higher than the first permittivity. The inner layer is preferably arranged in the form of a coating along an inner wall. Good results can be achieved when the tubular core, the inner layer and/or the cladding are co-extruded. Good results can be achieved when the first material has a dissipation factor in the range of $5E-05$ to $40E-05$. The cladding can be made from a second material having a lower permittivity than the first material. The inner layer can be made from a third material having a higher permittivity than the first material. Good results can be achieved, when the cladding is made from foamed first material. The cladding can be made from foamed polyethylene and/or expanded polytetrafluoroethylene. The inner layer can be made from the first material and comprising a filler having a higher permittivity than the first material. Filler material can be e.g. at least one out of the group of: alumina (aluminum oxide), fused quartz, fused silica, boron nitride, sapphire, magnesium oxide. When at least one filler material is added in the volume amount of 0.1% to 40% in the form of powder the melting temperature of the compound is not significantly different than the melting temperature of the first material. This is a significant advantage during production, e.g. by co-extrusion. Good results can be achieved when the tubular core has an inner diameter in the range of factor 0.5 to 2.0, respectively factor 0.7 to 1.5, respectively factor 1 with respect to the wavelength of the free progressive wave. Depending on the field of application the cladding can be encompassed by a protective jacket. If appropriate, the cladding can be coated on the outside by a coating made from a conductive material.

It is to be understood that both the foregoing general description and the following detailed description present embodiments, and are intended to provide an overview or framework for understanding the nature and character of the disclosure. The accompanying drawings are included to provide a further understanding, and are incorporated into and constitute a part of this specification. The drawings illustrate various embodiments, and together with the description serve to explain the principles and operation of the concepts disclosed.

BRIEF DESCRIPTION OF THE DRAWINGS

The herein described invention will be more fully understood from the detailed description given herein below and the accompanying drawings which should not be considered limiting to the invention described in the appended claims. The drawings are showing:

Fig. 1 a dielectric waveguide cable according to the prior art;

Fig. 2 a section of a dielectric waveguide cable according to the invention in a perspective;

Fig. 3 detail A of Figure 3;

Fig. 4 a diagram showing the transmission behavior of cable according to Figure 1;

Fig. 5 a diagram showing the transmission behavior of cable according to Figure 2.

DESCRIPTION OF THE EMBODIMENTS

Reference will now be made in detail to certain embodiments, examples of which are illustrated in the accompanying drawings, in which some, but not all features are shown. Indeed, embodiments disclosed herein may be embodied in many different forms and should not be construed as limited to the embodiments set forth herein; rather, these embodiments are provided so that this disclosure will satisfy applicable legal requirements. Whenever possible, like reference numbers will be used to refer to like components or parts.

Figure 1 shows a dielectric waveguide cable 10 according to the prior art. The cable comprises a core 11 and a jacket 12 surrounding the core 11. **Figure 4** is showing the transmission behavior of the cable 10 according to the prior art when bent at a radius of 40mm. As it can be seen, the signal is deviating from the center axis of the core 11 in an uncontrolled manner.

Figure 2 is showing a section of a dielectric waveguide cable 1 according to the invention in bend manner. **Figure 3** is showing detail A of **Figure 2** in an enlarged view. The dielectric wave guide cable 1 comprises a tubular core 2 made from a first material (low loss material) as e.g. described herein above having a certain permittivity. The tubular core 2 has an outer diameter 14 defined by an outer wall 17 and

an inner diameter 15 defined by an inner wall 18. The inner wall and the outer wall 17, 18 are preferably arranged concentric with respect to each other.

The tubular core is encompassed by a cladding 3 having, compared to the tubular core 2, a lower permittivity, e.g. due to material and/or geometry. The cladding 3
5 is preferably arranged concentric with respect to the tubular core.

The cladding 3 can be made from foamed polyethylene and/or expanded polytetrafluoroethylene or the like. Depending on the field of application the tubular core 2 has in the case of a circular cross section preferably an inner diameter in the range

of $D_{2\ inner}[mm] \approx \frac{240}{f_{lower}[GHz] * \sqrt{\epsilon_r\ high}}$ and an outer diameter in the range of

10 $D_{2\ outer}[mm] \approx \frac{1000}{f_{upper}[GHz] * \sqrt{\epsilon_r\ eff}}$. Although circular cross section would serve best for

preferred circular polarization transmission, other functionally similar polygonal cross section (e.g. square or hexagonal) may be chosen for production reasons e.g. to combine multiple waveguide cores in one cable. In this case the dimension should be chosen in that way, that the area of the cross section is in the similar

15 range than the circular one. The outer diameter of the cladding 4 preferably is in

the range of $D_4[mm] \approx \frac{2000}{f_{upper}[GHz] * \sqrt{\epsilon_r\ eff}}$. If appropriate, the cladding 4 can be en-

compassed directly or indirectly by a protective jacket 5. Furthermore the cladding 4 may be made of a polymer containing conductive material like metal particles or carbon.

The tubular core 2 normally comprises on the inside an inner layer 3, e.g. in the form of a coating and/or a coextruded layer, having a higher permittivity compared to the first material of the tubular core 2. Good results can be achieved when the inner layer 3 has a thickness in the range of $\delta_3 [mm] \approx \frac{60}{f_{lower} [GHz] \cdot \sqrt{\epsilon_{r3 high}}}$

- 5 In the subsequent table a selection of embodiments of dielectric waveguide cables are provided:

No.	Electrical performance	Tubular core (2)	Inner layer (3)	Cladding (4)
1	Loss: 4.9 dB/m @140 GHz group delay variation: 0.8 ps/m @110...140 GHz	PTFE; Er=2.1; tan delta=10E-05 D _{2outer} = 2.6 mm D _{2outer} = 1.0 mm	Polystyrene Er=2.5 tan delta = 100E-05 Thickness $\delta_3 = 0.245$	PE-foam Er=1.5 tan delta=13E-05 D _{4outer} = 4.6 mm
2	Loss: 4.4 dB/m @ 140 GHz group delay variation: 3.1 ps/m @110...140 GHz	PTFE; Er=2.1; tan delta=10E-05; D _{2outer} = 2.6 mm D _{2outer} = 0.8 mm	Polyphenylensulfid Er=2.8 tan delta = 100E-05 Thickness $\delta_3 = 0.2$	PE-foam Er=1.5 tan delta=13E-05 D _{4outer} = 4.6 mm
3	Loss: 4.6 dB/m @140 GHz group delay variation: 1.5 ps/m @110...140 GHz	PTFE; Er=2.1; tan delta=10E-05 D _{2outer} = 2.2 mm D _{2outer} = 0.6 mm	Polyetheretheketone Er=3.2 tan delta = 100E-05 Thickness $\delta_3 = 0.15$	PE-foam Er=1.5 tan delta=13E-05 D _{4outer} = 4.6 mm
4	Loss: 15 dB/m @140 GHz group delay variation: 3.2 ps/m @110...140 GHz	PTFE; Er=2.1; tan delta=10E-05 D _{2outer} = 2.6 mm D _{2outer} = 0.8 mm	Polyetheretheketone Er=3.2 tan delta = 100E-	PE-foam Er=1.5 tan delta=13E-05 D _{4outer} = 3.6 mm

			05 Thickness $\delta_3 = 0.25$	
5	Loss: 5 dB/m @140 GHz group delay variation: 2.8 ps/m @110...140 GHz	PE; Er=2.3; tan delta=5E-05 D _{2outer} = 2.0 mm D _{2outer} = 0.6 mm	Polyetheretheketone Er=3.2 tan delta = 100E-05 Thickness $\delta_3 = 0.15$	PE-foam Er=1.5 tan delta=13E-05 D _{4outer} = 3.6 mm

Figure 4 is schematically indicating the distribution of an electrical field 13 in the dielectric wave guide 10 as shown in **Figure 1**. The dielectric wave guide 10 is bend by a radius R1 which in the shown pictures is 40 mm.

- 5 **Figure 5** is schematically indicating the field the distribution of the electrical field 13 in the dielectric wave guide 1 according to the invention as shown in **Figure 2**. The dielectric wave guide 1 is bend by a radius R1 which in the shown pictures is 40 mm.

Rather, the words used in the specification are words of description rather than
 10 limitation, and it is understood that various changes may be made without departing from the Spirit and scope of the invention.

LIST OF DESIGNATIONS

	1	Cable (dielectric waveguide cable)
	2	Tubular core
	3	Coating (inner layer)
5	4	Cladding
	5	Jacket
	10	Cable
	11	Core
	12	Jacket
10	13	Electrical field
	14	Outer diameter tubular core (D2 outer)
	15	Inner diameter tubular core (D2 inner)
	16	Outer diameter cladding (D4 outer)
	17	Outer surface (tubular core)
15	18	Inner surface (tubular core)

PATENT CLAIMS

1. Dielectric wave guide cable (1) comprising a tubular core (2) made from a first material having a first permittivity, encompassed by a cladding (4) having, compared to the tubular core (2), a second permittivity which is lower than the first permittivity **wherein** the tubular core (2) comprises on the inside an inner layer (3) having a third permittivity which is higher than the first permittivity.
2. The dielectric wave guide cable (1) according to claim 1, **wherein** the first material has a dissipation factor in the range of 5E-05 to 40E-05.
3. The dielectric wave guide cable (1) according to at least one of the previous claims, **wherein** the cladding (4) is made from a second material having a lower permittivity than the first material.
4. The dielectric wave guide cable (1) according to at least one of the previous claims, **wherein** the inner layer (3) is made from a third material having a higher permittivity than the first material.
5. The dielectric wave guide cable (1) according to at least one of the previous claims, **wherein** cladding (3) is made from foamed first material.

6. The dielectric wave guide cable (1) according to at least one of the previous claims, **wherein** cladding (3) is made from foamed polyethylene and/or expanded polytetrafluoroethylene.
7. The dielectric wave guide cable (1) according to at least one of the previous claims, **wherein** the inner layer (3) is made from the first material and comprising a filler having a higher permittivity than the first material.
8. The dielectric wave guide cable (1) according to at least one of the previous claims, **wherein** the tubular core (2) has an inner diameter in the range of factor 0.5 to 2.0, respectively factor 0.7 to 1.5, respectively factor 1 with respect to the wavelength of the free progressive wave.
9. The dielectric wave guide cable (1) according to at least one of the previous claims, **wherein** the cladding (4) is encompassed by a protective jacket (5).
10. The dielectric wave guide cable (1) according to at least one of the previous claims, **wherein** the cladding (4) is coated on the outside by a coating made from a conductive material.
11. The dielectric wave guide cable (1) according to claim at least one of the previous claims, **wherein** the inner layer (3) has a thickness calculated according to the formula:

$$\sim \frac{30}{f_{lower}[GHz] * \sqrt{\epsilon_r high.}} [mm]$$

12. The dielectric wave guide cable (1) according to at least one of the previous claims, **wherein** the tubular core (2) has a circular cross section or a polygonal cross section.
- 5 13. The dielectric wave guide cable (1) according to at least one of the previous claims, **wherein** the cladding (4) has a circular or polygonal cross section.

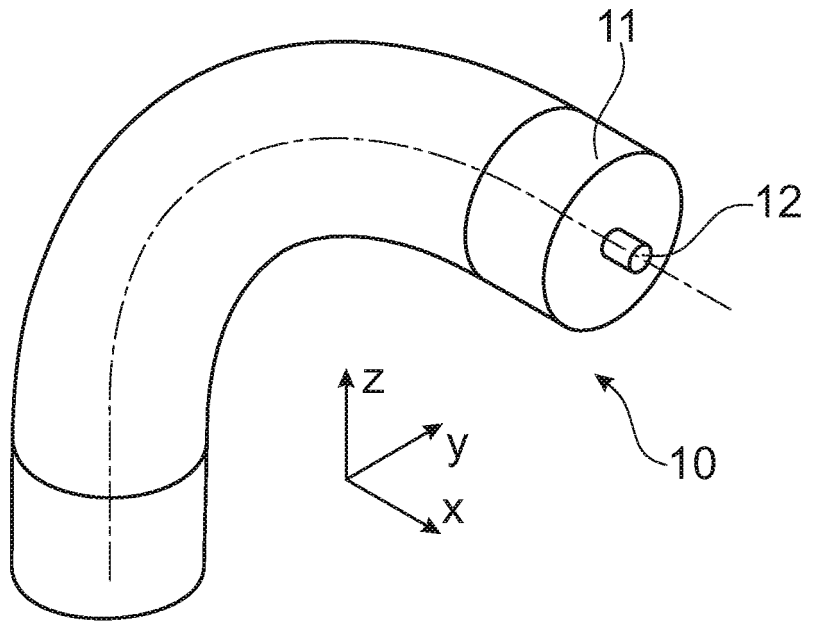

Fig. 1 (prior art)

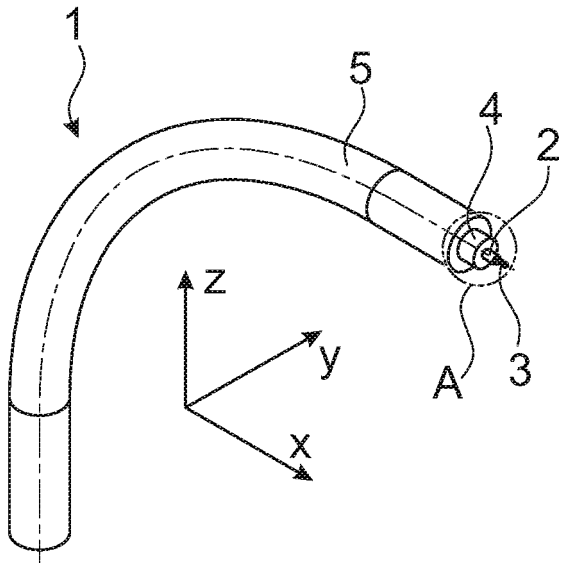

Fig. 2

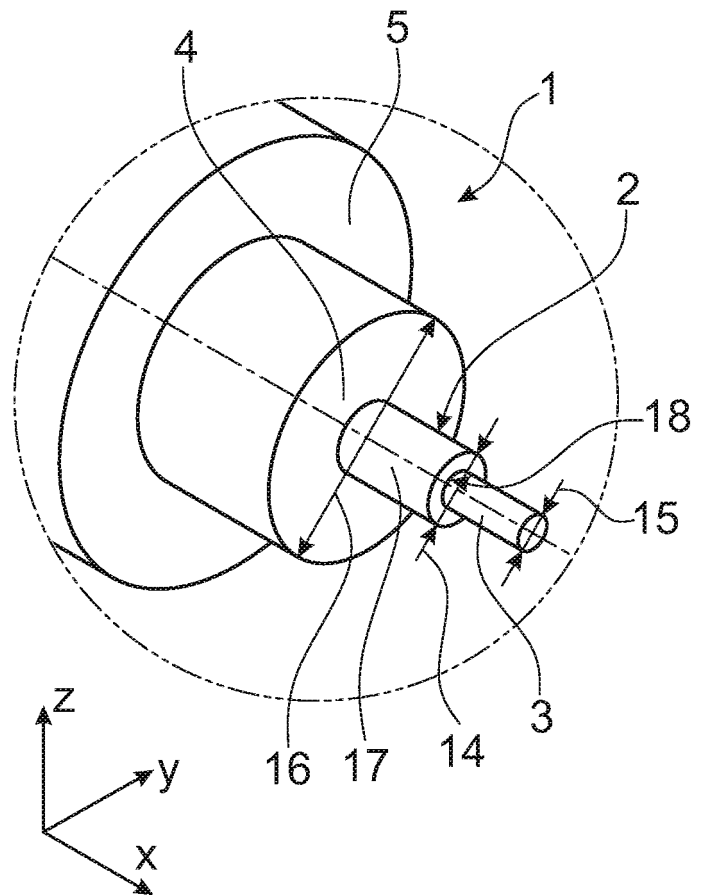

Fig. 3

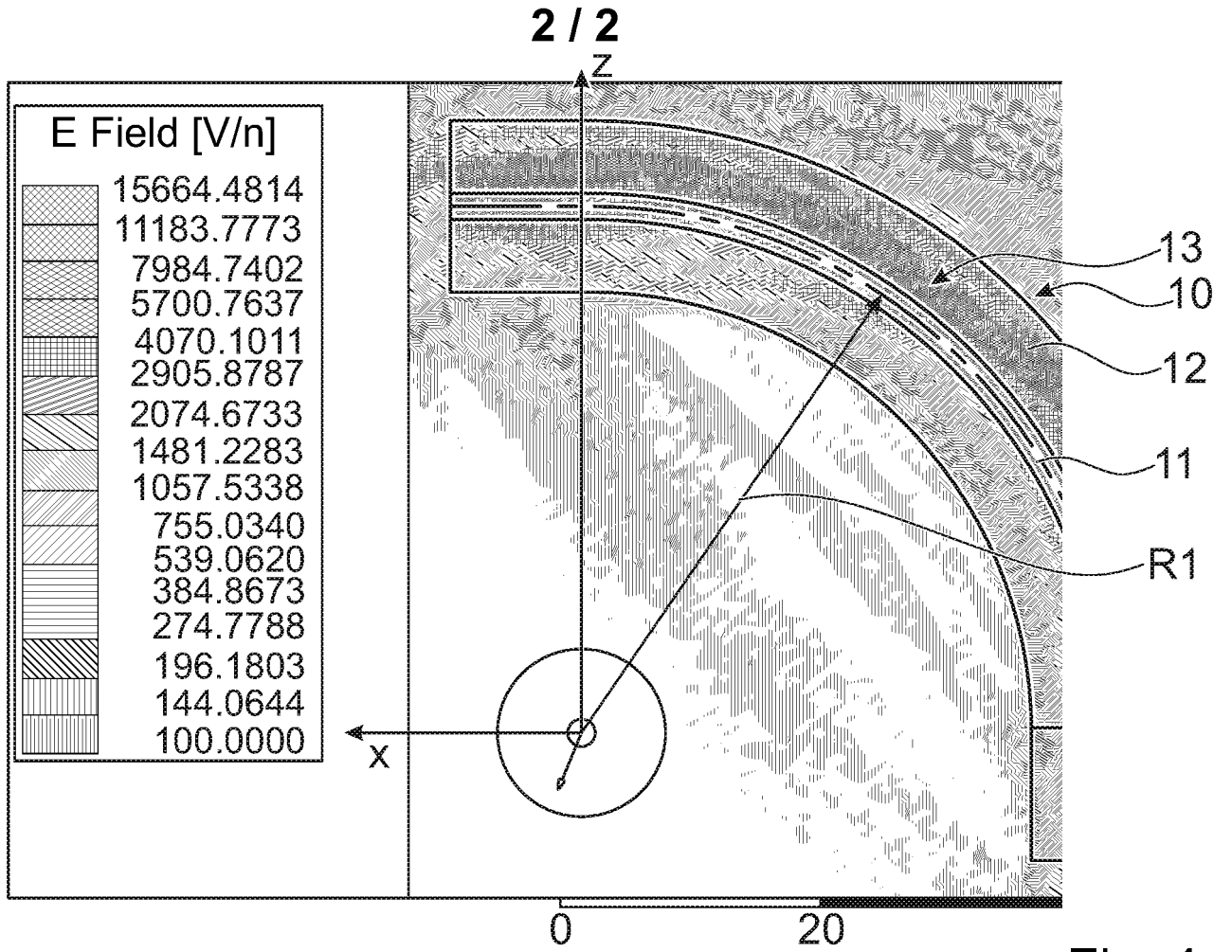

Fig. 4

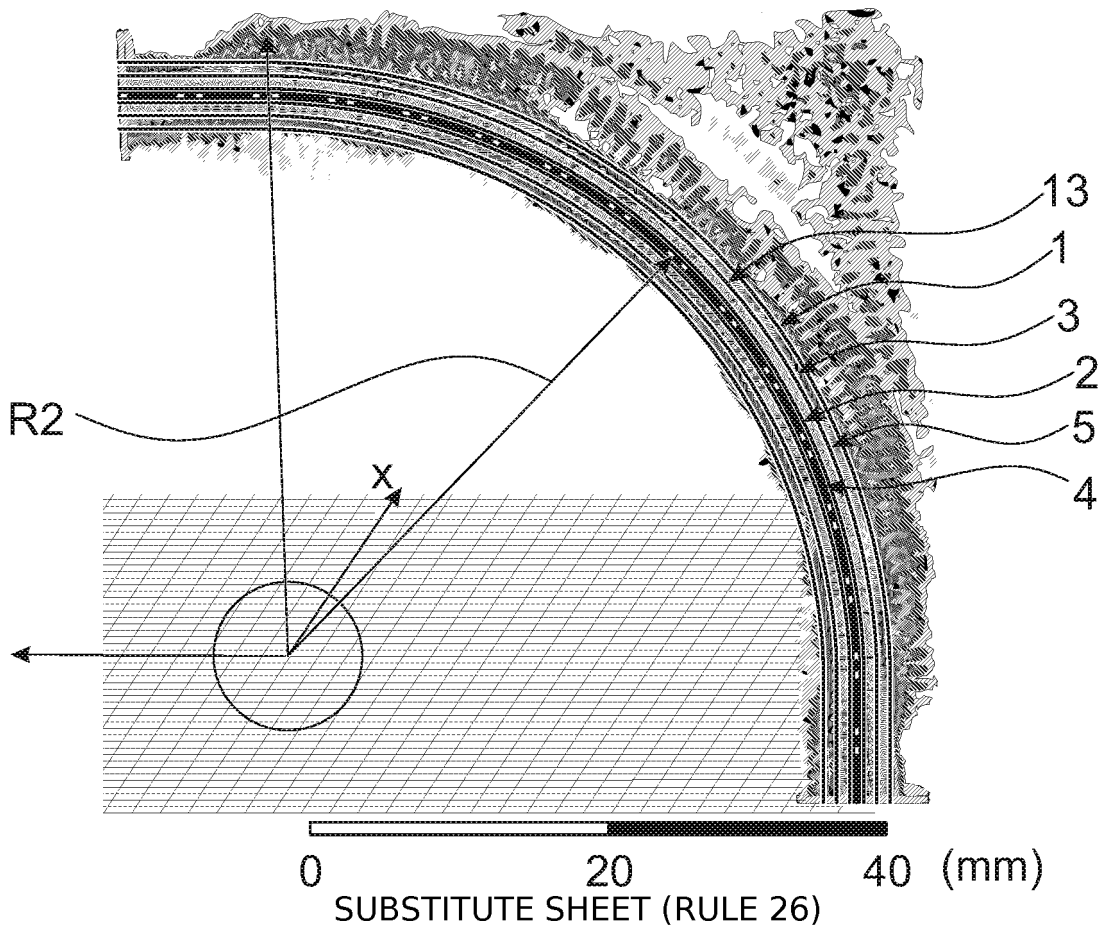

Fig. 5

INTERNATIONAL SEARCH REPORT

International application No
PCT/EP2019/084547

A. CLASSIFICATION OF SUBJECT MATTER

INV. H01P3/16 G02B6/036 G02B6/032
ADD.

According to International Patent Classification (IPC) or to both national classification and IPC

B. FIELDS SEARCHED

Minimum documentation searched (classification system followed by classification symbols)

H01P G02B

Documentation searched other than minimum documentation to the extent that such documents are included in the fields searched

Electronic data base consulted during the international search (name of data base and, where practicable, search terms used)

EPO-Internal, WPI Data

C. DOCUMENTS CONSIDERED TO BE RELEVANT

Category*	Citation of document, with indication, where appropriate, of the relevant passages	Relevant to claim No.
X	US 5 963 700 A (KATO MASAO [JP] ET AL) 5 October 1999 (1999-10-05)	1,12,13
Y	column 4, line 32 - column 4, line 50;	2-10
A	figure 1	11
Y	----- EP 3 306 740 A1 (ROSENBERGER HOCHFREQUENZTECHNIK GMBH & CO KG [DE]) 11 April 2018 (2018-04-11) cited in the application	2-10
A	page 3, paragraph 20 page 3, paragraph 24 - page 3, paragraph 28 page 3, paragraph 31 - page 3, paragraph 32 page 6, paragraph 64 - page 6, paragraph 66; claims 3, 15; figure 8 ----- -/--	1,11-13

 Further documents are listed in the continuation of Box C. See patent family annex.

* Special categories of cited documents :

"A" document defining the general state of the art which is not considered to be of particular relevance

"E" earlier application or patent but published on or after the international filing date

"L" document which may throw doubts on priority claim(s) or which is cited to establish the publication date of another citation or other special reason (as specified)

"O" document referring to an oral disclosure, use, exhibition or other means

"P" document published prior to the international filing date but later than the priority date claimed

"T" later document published after the international filing date or priority date and not in conflict with the application but cited to understand the principle or theory underlying the invention

"X" document of particular relevance; the claimed invention cannot be considered novel or cannot be considered to involve an inventive step when the document is taken alone

"Y" document of particular relevance; the claimed invention cannot be considered to involve an inventive step when the document is combined with one or more other such documents, such combination being obvious to a person skilled in the art

"&" document member of the same patent family

Date of the actual completion of the international search

1 April 2020

Date of mailing of the international search report

09/04/2020

Name and mailing address of the ISA/

European Patent Office, P.B. 5818 Patentlaan 2
NL - 2280 HV Rijswijk
Tel. (+31-70) 340-2040,
Fax: (+31-70) 340-3016

Authorized officer

Blech, Marcel

INTERNATIONAL SEARCH REPORT

International application No
PCT/EP2019/084547

C(Continuation). DOCUMENTS CONSIDERED TO BE RELEVANT

Category*	Citation of document, with indication, where appropriate, of the relevant passages	Relevant to claim No.
A	US 4 441 091 A (NISHIDA SHIGEO [JP] ET AL) 3 April 1984 (1984-04-03) column 3, line 53 - column 4, line 32; figure 3 -----	1-13

INTERNATIONAL SEARCH REPORT

Information on patent family members

International application No PCT/EP2019/084547

Patent document cited in search report	Publication date	Patent family member(s)	Publication date	
US 5963700	A	05-10-1999	DE 69837506 T2 EP 0862069 A2 US 5963700 A	27-12-2007 02-09-1998 05-10-1999

EP 3306740	A1	11-04-2018	CN 109565100 A EP 3306740 A1 KR 20190065239 A WO 2018068914 A1	02-04-2019 11-04-2018 11-06-2019 19-04-2018

US 4441091	A	03-04-1984	JP S5616303 A JP S6232841 B2 US 4441091 A	17-02-1981 17-07-1987 03-04-1984
