



UNIVERSITÀ  
DEGLI STUDI  
FIRENZE

## FLORE

# Repository istituzionale dell'Università degli Studi di Firenze

### **Innovative composites and hybrid materials for electric vehicles lightweight design in a sustainability perspective**

Questa è la Versione finale referata (Post print/Accepted manuscript) della seguente pubblicazione:

*Original Citation:*

Innovative composites and hybrid materials for electric vehicles lightweight design in a sustainability perspective / Massimo, Delogu; Laura, Zanchi; Caterina Antonia Dattilo, ; Marco, Pierini. - In: MATERIALS TODAY COMMUNICATIONS. - ISSN 2352-4928. - ELETTRONICO. - 13:(2017), pp. 192-209. [10.1016/j.mtcomm.2017.09.012]

*Availability:*

The webpage <https://hdl.handle.net/2158/1107872> of the repository was last updated on 2021-03-30T12:00:52Z

*Published version:*

DOI: 10.1016/j.mtcomm.2017.09.012

*Terms of use:*

Open Access

La pubblicazione è resa disponibile sotto le norme e i termini della licenza di deposito, secondo quanto stabilito dalla Policy per l'accesso aperto dell'Università degli Studi di Firenze (<https://www.sba.unifi.it/upload/policy-oa-2016-1.pdf>)

*Publisher copyright claim:*

Conformità alle politiche dell'editore / Compliance to publisher's policies

Questa versione della pubblicazione è conforme a quanto richiesto dalle politiche dell'editore in materia di copyright.

This version of the publication conforms to the publisher's copyright policies.

La data sopra indicata si riferisce all'ultimo aggiornamento della scheda del Repository FloRe - The above-mentioned date refers to the last update of the record in the Institutional Repository FloRe

(Article begins on next page)

# Innovative composites and hybrid materials for electric vehicles lightweight design in a sustainability perspective

M. Delogu<sup>a</sup>, L. Zanchi<sup>a</sup>, C.A. Dattilo<sup>a</sup>, M. Pierini<sup>a</sup>

<sup>a</sup> Department of Industrial Engineering, University of Florence, via Santa Marta 3, 50139 Florence, Italy

## Highlights.

- Innovative materials for lightweight design of electric vehicles are studied.
- Comparative LCA of EVs components are performed, without resizing powertrain.
- Primary data collection on novel composites and hybrid materials.
- Four-level approach for LCA results interpretation is proposed.
- Trade-off between the production and use stages is treated.

## Abstract.

Lightweight design and electrified powertrain have become important strategies in the automotive industry to reduce fuel demand and break down emissions respectively. Lightweighting of Electric Vehicles (EVs) is considered a step forward because advantages of both EVs and lightweight design could be combined to reduce environmental impacts even further. This paper would contribute to the advancement of knowledge in this field and it deals with the environmental analysis, by means of Life Cycle Assessment (LCA), of composite-based and hybrid material lightweight solutions for EVs modules in comparison with the corresponding reference ones, by assuming no changes in the powertrain system (e.g. battery resizing). Particular attention is given to primary data collection to build the environmental eco-profiles of four innovative composites. Then, a four-level approach to interpret LCA outcomes in a clear and comprehensive way is proposed in this paper. Despite the relevant mass reduction, environmental benefits are not registered for all the analysed solutions, and the main reason is the large impact from the production stage of the new materials, raw materials particularly. Outcomes from this paper showed that Abiotic Depletion Potential ( $ADP_{el}$ ) generally had a different trend if compared to Global Warming Potential (GWP) and Primary Energy Demand (PED) so their evaluation in parallel is recommended. Overall, the innovative materials that have a high impact in the production stage could not be suitable in the case of EVs where the emission rate in the use stage is lower than the one of traditional vehicle, so a different application should be also evaluated.

## Graphical abstract

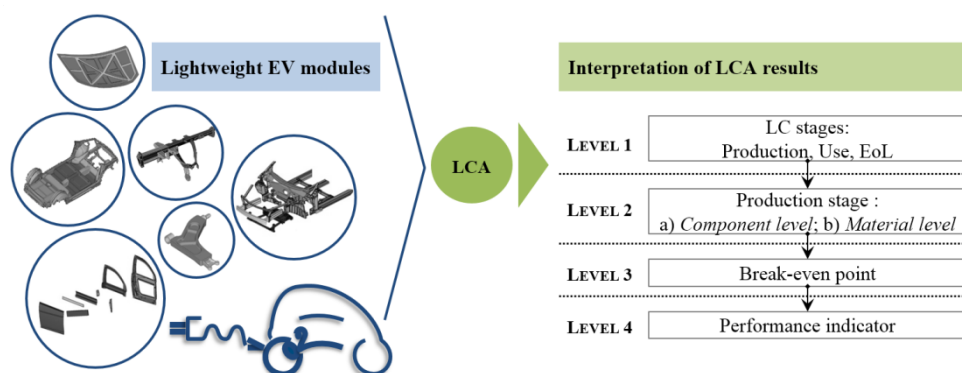

**Keywords.** Life Cycle Assessment; composites; hybrid material; lightweight; electric vehicles.

## 1 Introduction

Transport sector represents almost a quarter of Europe's greenhouse gas (GHG) emissions and is the main cause of air pollution in cities. In particular, road transport is by far the biggest emitter accounting for more than 70% of all GHG emissions from transport in 2014 [1]; moreover vehicles are responsible for a huge depletion of natural resources for materials and fuels production. In the recent years, the car manufacturers have been implementing several technical

solutions to meet EU legislation requirements (2009/443/EC, 2000/53/EC, 2014/95/EU) and satisfy consumer expectations. One of the key challenge is the road transport decarbonisation [2]; at this regard, the main strategies to face this problem include alternative propulsion systems, mass reduction, aerodynamics and engine efficiency improvements [3].

Lightweight design has become an important lever in the automotive industry since it is proved to produce effective fuel demand reduction and emissions abatement. Lightweighting relies on mass vehicle reduction by means of material substitution, coupled with vehicle component redesign, while maintaining vehicle size and so satisfying consumer demand. The reduction of impacts from Internal Combustion Engine Vehicles (ICEV) by means of lightweight materials has been extensively examined in the recent years. In this context, Life Cycle Assessment (LCA) is the methodology mostly used to evaluate environmental impacts and compare alternative design solutions. Several studies have applied LCA to explore benefits stemmed from lightweight materials if compared to traditional ones in the ICEV design [4, 5, 6, 7, 8, 9]. Many LCA studies examined the substitution of metals (generally steel) with fibre-reinforced plastics [9, 10, 11, 12, 13], while only a small number of works compared alternative composites solutions (i.e. bio-polymers and bio-composites) [14, 15, 16] and new metals alloys [17, 18]. Steel is generally proved to provide a large potential for mass reduction and its replacement with high strength steel, advanced high strength steel or cast aluminium enables GHG emissions reduction since from the production stage. On the other hand, wrought aluminium, carbon-fibre reinforced plastic (CFRP) and magnesium yield relevant mass reduction but at the cost of GHG emissions increase during material processing. In other cases, LCA is used to evaluate environmental impacts of EVs over the traditional ones [19, 20, 21].

Lightweighting of EVs could represent a step forward because advantages of both EVs and lightweight design could be combined to reduce environmental impacts even further [22]; in addition, the application of lightweight materials in the EVs is expected to be particularly profitable since mass reduction could improve performances in terms of drive distances and battery size containment [23]. Overall, still few works exist about this topic [24, 25] and there is a great deal of room for improvements in this field. Indeed, present EVs are mainly based on ICEV architecture, expect for specific EV components and body reinforcements, thus resulting into a total high vehicle mass; exceptions are perhaps the Tesla Roadster and the BMWi models. In particular, the intrinsic qualities of composite materials and their integration in multi-material assemblies have not yet been explored. Unlike the advanced lightweight alloys, which offer moderate weight savings, novel CFRP solutions could bring stronger weight savings that making them particularly profitable for the EVs.

Developments on specific design methodologies and innovative production technologies are also supporting the multi-material design as a way to achieve further mass reduction [26]; however, the environmental consequences of hybrid design in comparison with mono-material one is still unexplored, to the best knowledge of authors [27]. Consequently, the development and application of novel lightweight measures have become more important over the past years and advancements in materials research, and related manufacturing technologies, play an important role.

Due to the wide variety of materials and the different functional specifications of several vehicle modules, the material selection process needs to balance many aspects (technical performances and feasibility, materials recyclability, environmental impact of material production); this leads to face controversial issues and trade-off necessarily [18, 25, 27, 28, 29]. For instance, from an environmental point of view, the use of lightweight materials is often responsible for increase in the production stage impact, particularly materials processing, thus counterbalancing the expected benefit during use stage [25, 27]. GHG emissions and life-cycle energy demand are generally the most investigated impact categories when lightweighting is addressed [25, 27, 30]; however, to investigate the sensitive trade-off between production and use stages, the selection of proper environmental impact categories, beyond these indicators, appears fundamental [16, 24]. Defining a set of environmental indicators targeted to the given sector is generally debated as an opportunity to strength the LCA methodology and its role as a supporting tool in the early design phase of automotive products [19, 29, 31, 32].

This paper deals with the environmental assessment, by means of LCA, of lightweight solutions specifically developed for EV components based on innovative materials belonging to four classes: thermoplastic matrix composites, fibre reinforced thermoset matrix composites, advanced hybrid materials and bio-composites made from renewables. Lightweight materials and their application were developed within the EU-project ENLIGHT according to a module-specific lightweight approach. The project aim was to advance highly innovative lightweight material technologies for application in structural vehicle parts of future EVs along four axes: performance, manufacturability, cost effectiveness and lifecycle footprint [23]. Therefore, this study provides real examples of composite-based and hybrid material design solutions for EV lightweight purpose. Besides their technical feasibility, their environmental performances are analysed by means of LCA in comparison with the corresponding reference solutions, by assuming no

changes in the powertrain system (e.g. motor adaptation, battery resize). To comply with the requirements of data accuracy for an LCA, a particular attention is dedicated to primary data collection to build the environmental eco-profiles of the innovative lightweight materials and technologies, currently not covered by the commercial database.

Efforts are also dedicated to discuss and enlarge the environmental assessment to a diverse set of impact categories, in addition to the CO<sub>2</sub> emissions, according to the current research directions. A clear and complete visualization of results is considered fundamental for a comprehensive interpretation and to guide decision toward the best choice [24]. To enhance a structured and exhaustive interpretation of results, in this paper, a four-level approach is proposed. Global Warming Potential (GWP), Abiotic Potential Depletion elements (ADP<sub>el</sub>) and Primary Energy Demand (PED) will be looked into especially.

This paper is structured as follows: definition of the method and levels of LCA results interpretation (chapter 2); description of the lightweight solutions for the analysed EV components with particular regards to the innovative materials and technologies (chapter 3); goal and scope definition and inventory data (chapter 4); LCA results and discussion (chapter 5); conclusions (chapter 6).

## 2 Method

The method adopted in this paper mainly relies on a typical LCA structure (according to ISO 14040:2006 and ISO 14044:2006). Overall, the LCA was carried out within each module design workflow as well as materials development and technologies phases, representing powerful instruments to compare different design/materials/technologies alternatives and to orient towards sustainable solutions. In this paper only results concerning the finalized design solutions, and related materials, are reported. Therefore, first materials and manufacturing technologies are described in a way that allows identifying reasons behind their selection and reconstruct the processes involved in the materials processing and manufacturing to build their eco-profiles (paragraph 3.1). All the studied components are described (paragraph 3.2), then a description of all the relevant data and key parameters defined for the LCA elaboration are provided (paragraphs 4.1 and 4.2). The LCA was developed by taking into account directions from the International reference Life Cycle Data system (ILCD) handbook [33] and eLCAr project [31] providing guidelines for the LCA of EVs. Moreover, due to the presence of multi-material design solutions, a *breakdown approach*, consisting on the analysis of each mono-material part of the modules, is applied in order to guarantee data accuracy and enhance comparison between reference and lightweight solutions. As a consequence, LCA outcomes for each module are obtained as the sum of LCA of several mono-material parts. To comply with the requirements of an accurate and complete LCA results examination, a four-level flow chart guiding the results interpretation is applied (**Figure 1**).

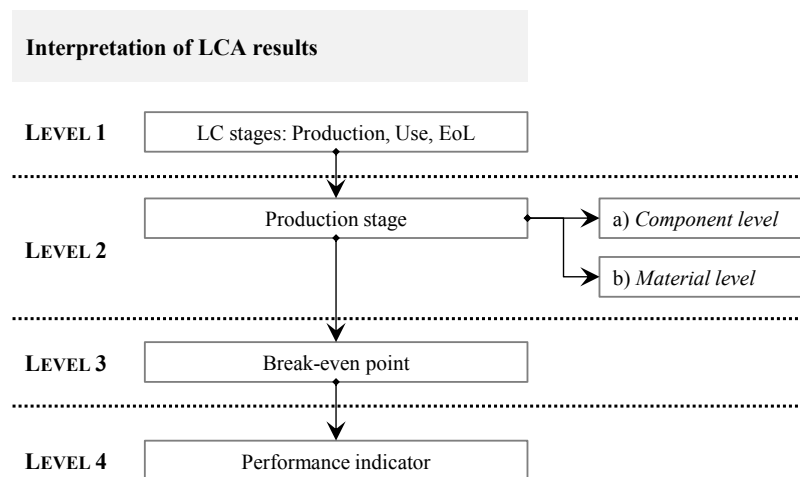

**Figure 1** Flow chart describing different levels of LCA results interpretation

The first three levels – Life Cycle stages, Production stage and Break-even point - are generally present in the studies from literature, however they are often partially developed or not clearly structured, thus hindering a comprehensive results interpretation and comparison between works [24]. The fourth level, on the contrary, concerns new indicators to investigate the relationship between impacts and some design elements.

The first level (Level 1) concerns the analysis of the contribution of each Life Cycle (LC) stage - *Production*, including materials and manufacturing; *Use* and *End-of-Life* (EoL) - to the different environmental categories, and comparing them in the reference (Ref) and lightweight (Light) solutions. The Life Cycle Impact Assessment (LCIA) is performed according to the CML 2001 method and Primary Energy Demand (PED); reasoning behind the categories selection are described in the corresponding chapter 5. According to literature findings, *Production* of EVs represents the most critical and impacting stage particularly when composites are applied [24]; therefore, Level 2 provides a focus on that stage both at *component* and *material level* in order to identify the processes/raw materials responsible for the greatest impact.

In Level 3, the break-even analysis is used to evaluate the convenience of a solution by identifying at which vehicle's life distance the lightweight solution could give environmental benefit if compared to the reference one; GWP is usually adopted as main environmental indicator for the use stage [16, 34]. According to the recent research directions [24], to have more insights upon advantages/disadvantages stemmed from a lightweight solution, it has to be compared both to the reference solution in the EV case as well as in the ICEV one. For this reason, the break-even analysis is performed in both cases by assuming that the components could fit both vehicle architectures.

Overall, there is not a universally preferable lightweight solution over the traditional one since many case-specific aspects could affect the final outcome (e.g. electricity mix, use pattern) and also because the several impact categories generally show different behaviour. Therefore, in the Level 4 the attempt is to extract considerations in terms of elements most affecting results and enhance further improvements. With this aim, an additional indicator, named *performance indicator*, is proposed to evaluate the relationships between impacts and three design aspects: material pairs, mass reduction and the EoL.

### 3 Lightweight solutions for EV components

#### 3.1 Materials and Technologies

Within the ENLIGHT project four materials classes, and related manufacturing technologies, were investigated: thermoplastic matrix composites, fibre reinforced thermoset matrix composites, advanced hybrid materials and bio-composites made from renewables. A detailed description of materials and manufacturing technologies developed in the project is not reported in this paper since out of its scope. However, an overview of the materials and technologies applied for the six modules is provided.

According to the project target, the investigated materials are to allow manufacture at medium production volume (around up to 50000 EVs), providing affordable vehicle solutions with improved functionality, safety and environmental impacts. Materials properties, in terms of mechanical and processability, were investigated along with various approaches of reinforcement (i.e. continuous or short fibre). The application in different vehicle modules was analysed, then a selected number was tested for some specific component of an electric vehicle.

As far as bio-composites is concerned, the materials developed in the project are either fully or partially bio-based; in particular, the PA410 matrix from DSM, currently 70% bio-based, was selected among thermoplastics.

The level of reinforcement was analysed taking into account both carbon and glass fibre; moreover, both chopped and continuous fibre solutions were approached in design optimizations of the modules. New types of continuous fibre solutions were further investigated by Oxeon and DSM to form spread fibre tows and Uni-Directional (UD) tapes, respectively, that can be used for producing ultra-light laminates that consist of either stacked of UD plies or stacks of spread-tow Woven Tapes (WT). These ultra-light weight reinforcements are produced by means of the processes steps reported in **Figure 1**. In the case of thermoset resin, the process, developed by Oxeon, compels dried spread fibre tows production that is followed, when required, by WT resin infusion by liquid composite moulding to achieve complex composite parts (**Figure 1**). Whereas in the case of thermoplastic matrix the process, developed by DSM, includes UD-tape production, which is followed, when required, by WT process (according to the Oxeon technology) or stacked plies process (**Figure 1**).

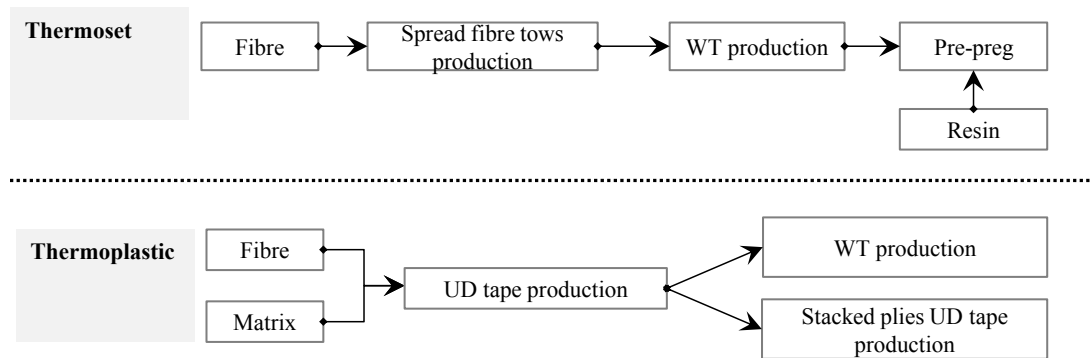

**Figure 2** Innovative composite production process sequence: thermoplastic and thermoset

Carbon-based and glass-based materials incorporating PA410 and traditional resins (e.g. epoxy) have been studied and selected as following:

- PA410-CF60 - applied to Front Module, Front Door and Cross Dashboard Beam;
- PA410-GF60 - applied to Cross Dashboard Beam and Central Floor Section;
- Epoxy Resin-CF70 – applied to Front Hood and Suspension Arm 1;
- Vinyl Ester-CF53 - applied to Front Hood and Suspension Arm 2.

These materials are extensively used in sporting goods and formula one for their high performance and aesthetics, but they have never been employed in automotive applications.

The selection of advanced hybrid materials is mainly guided by the possibility of obtaining several advantages with respect to mono-material design such as high strength, high stiffness and low mass. The combination of reinforced thermoplastic with aluminium alloys was one of the project focus and its potentialities have been investigated for several modules (paragraph 4.2.1). Evaluating suitable joining techniques (i.e. adhesive bonding) is one of the most important challenge for hybrid materials application. For this reason, efforts were dedicated on more integrated manufacturing technologies rather than single adhesive joints.

Several manufacturing technologies for the efficient production of ultra-light weight structure in hybrid material designs have been studied. A first example regards vinyl ester resin reinforced by long chopped carbon fibres that works together with aluminium inserts in the suspension arm component (paragraph 4.2.1). In this case, an Engineered Structural Composites (ESC) based on vinyl ester and chopped fibres (sheet form) is manufactured by means of Advanced Sheet Moulding Compression (ASMC) consisting of the following steps: ESC placement on the hot mould with pre-heated metallic inserts; co-moulding process; cooling time in a controlled atmosphere; removing of the parts. This process enables complex geometries realization also with long fibres, proving components with higher stiffness if compared to the ones produced by injection moulding. The ASMC process allows co-moulding the metallic inserts directly during the step of part manufacturing, thus eliminating further machining a joining operation; the cohesion between composite and metal is very strong due to the high forming pressures uses during the process. In a second suspension arm solution, the HP-RTM (Resin Transfer Moulding) technology has been selected since particularly favourable to meet the targeted production volume. The following steps characterize the typical manufacturing process: placement preform reinforcement (fibre fabric) in the cavity; closing the mould and resin injection under pressure control; consolidation; closing of the resin valves and opening of the mould; removal of component. Another integrated manufactured technology is proposed for the Cross Dashboard Beam where aluminium part and carbon fibre reinforced thermoplastic are produced by means of over-moulding process. A process for Continuous Fibre Placements (CFP) of thermoplastic composite pipes has been investigated by Airborne with the aim of developing a continuous process to produce tubular profiles with a high production rate and low cost per part. The analysed CFP process is based on connected mandrels that move through a series of CFP stations. Each CFP station adds a layer of composite with a certain fibre orientation and consolidates it in-situ. In particular, this process was applied for the intrusion beam of the Front Door and front longitudinal member of Front Module (paragraph 4.2.1)

### 3.2 Description of components

The environmental analysis is performed on the following EV components (**Figure 3**): Front Module (FM); Front Hood (FH); Front Door (FD); Cross Dashboard Beam (CDB); Suspension Arm (SA); Central Floor Section (CSF).

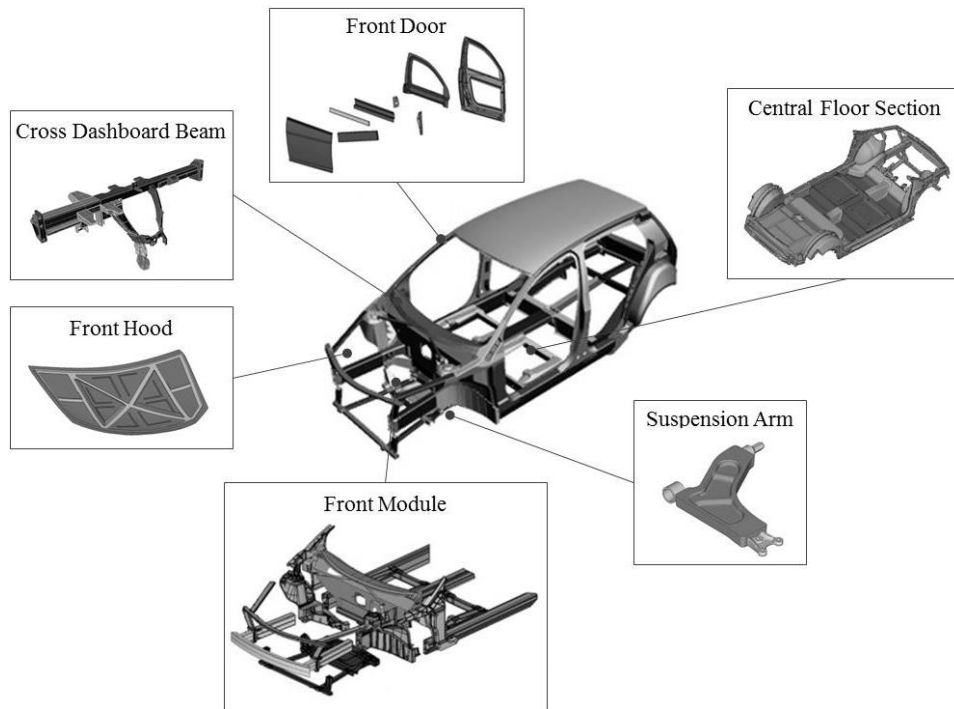
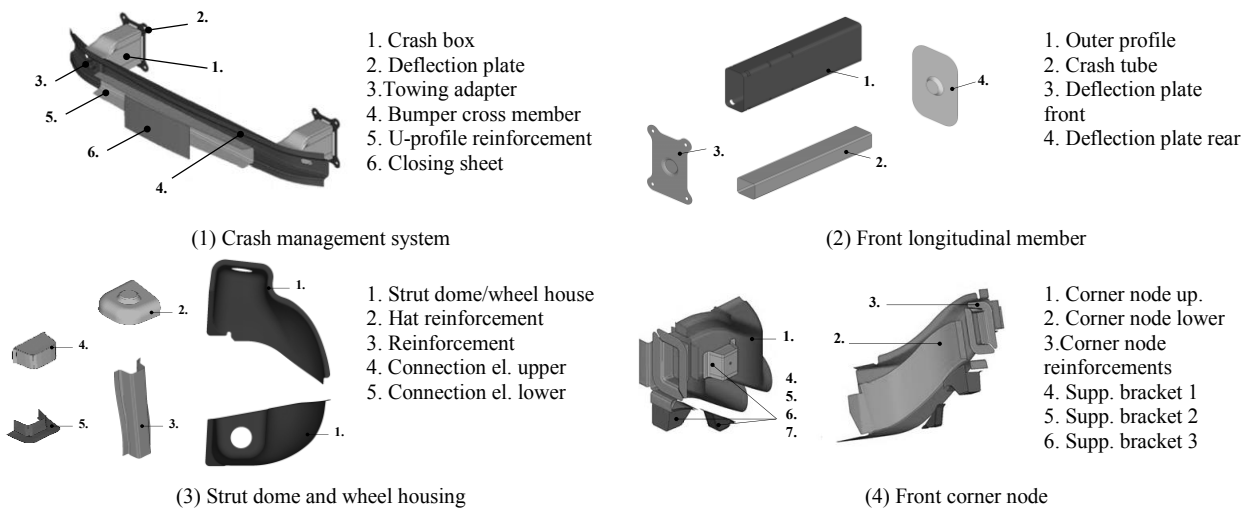

**Figure 3** Location of EV components

### Front Module (FM)

The FM of a vehicle is an aggregate of components located in its front part which are preassembled as subassembly ready to be installed into the vehicle. In this work, the front module consists of four sub-modules (**Figure 4**) : 1) *crash management system*, 2) *front longitudinal member*; 3) *strut dome and wheel housing*; 4) *front corner node*.

Further details in terms of materials and technologies are reported in the following **Table 1** (paragraph 4.2.1).



**Figure 4** FM sub-modules

### Front Hood (FH)

The FH includes two main mono-material parts (**Figure 5**): 1) *inner part*; 2) *outer part*.

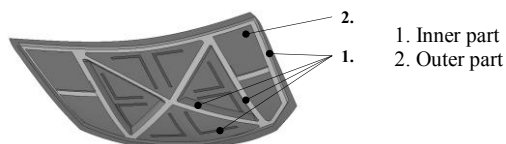

**Figure 5** FH mono-material parts

### Front Door (FD)

The FD consists of different mono-material parts as **Figure 6** describes.

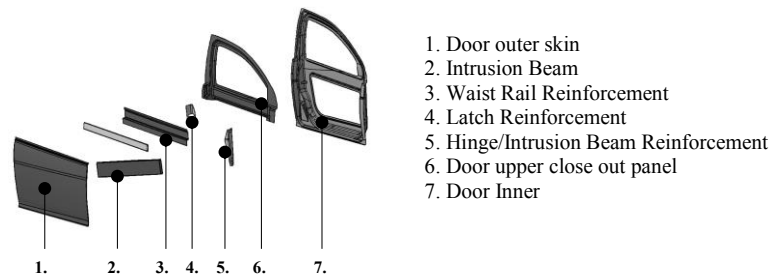

**Figure 6** FD mono-material parts

### Cross Dashboard Beam (CDB)

The CDB developed in ENILGHT project is made of five main parts as detailed in **Figure 7**.

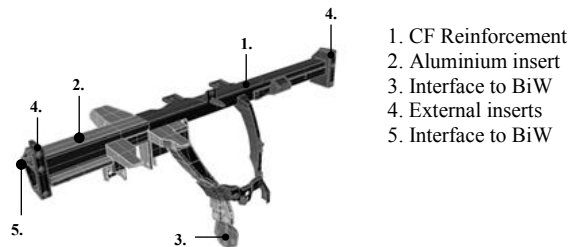
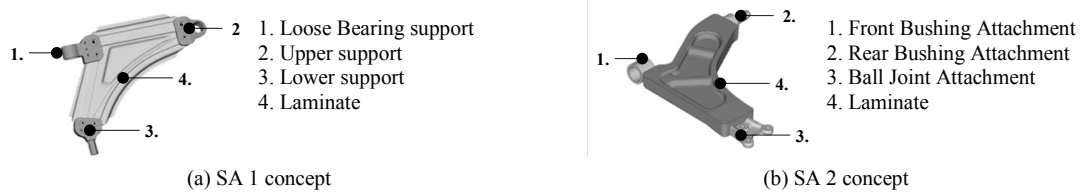

**Figure 7** CDB mono-material parts

### Suspension Arm (SA)

The SA component belongs to the suspensions system module. This study examines two different lightweight solutions of SA developed by LBF (**Figure 8-a**: SA 1) and Magneti Marelli (MM) (**Figure 8-b**: SA 2) respectively.

In particular, the SA1 component is manufactured using the new technology called Resin Transfer Molding (RTM), while the SA 2 arm is realized using an Advanced Sheet Compression Molding (ASCM)



**Figure 8** Suspension Arms mono-material parts

### Central Floor Section (CFS)

The central floor section, developed by Centro Ricerche Fiat (CRF), includes different parts as reported in **Figure 9**.

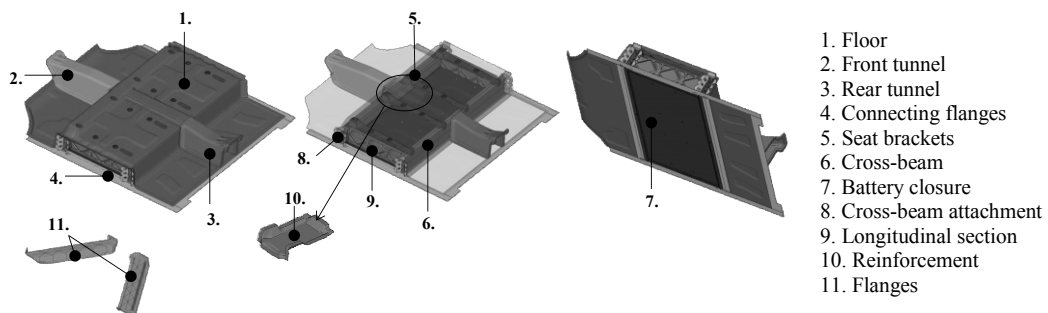

**Figure 9** Central floor mono-material parts

## 4 Life Cycle modelling

### 4.1 Goal and scope

The goal of this study is evaluating the environmental performance along the entire life cycle (Production, Use, EoL) of the innovative lightweight solutions for EV components previously described, developed within ENLIGHT project, if compared to the current reference solutions. For each module the functional unit (FU) adopted corresponds to one module mounted over an EV with a life-distance of 150000 km for 10 years; the comparability between the reference and light solutions of a given module is guaranteed by the same functionality.

System Boundaries include all processes associated to the modules life cycle stages: *Material Production*; *Manufacturing*; *Use*; *EoL*. The diagram in **Figure 10** shows a generic scheme of stages and sub-stages representative for all the modules included in the LCA boundaries. In this study, transportations have been excluded since specific geographical locations were not identified, moreover their impact is generally low [8, 16].

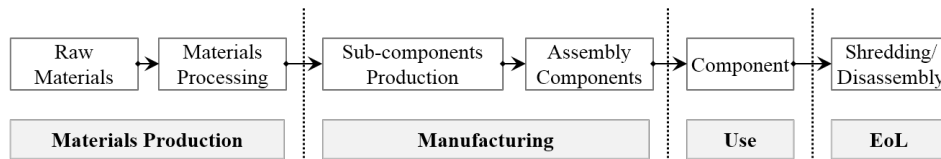

**Figure 10** System Boundaries of modules

### 4.2 Life Cycle Inventory

Life Cycle Inventory (LCI) compels *data collection* and *environmental modelling*. In particular, the first fulfils the collection of data regarding LC stages of examined modules in order to get also information about the behaviour of their systems. The data quality is very important for the results accuracy; overall, they can be classified in: *primary data* (i.e. direct measurement/description of variables); *secondary data* (i.e. published articles, technical reports or databases); *assumptions*, when primary or secondary data are not available. During the modelling phase all the elementary flows and products/waste flows, characterizing the several processes of the modules LC, are quantified and linked. In this study, the environmental modelling has been carried out by using a breakdown approach consisting in the analysis of each mono-material part of the modules. The LCI involved a large amount of data that were collected by means of questionnaires spread to designers, materials and manufacturing technologies providers within the project consortium.

#### 4.2.1 Production stage

To perform the LCI modelling of Production stage, an accurate data collection is conducted by a detailed analysis of inputs and outputs exchanged between the several steps of the technological processes. Applying this principle to each mono-material part of the modules, a concatenation of processes for each sub-parts/sub-modules was obtained. **Table 1** – **Table 6** report information of each *sub-modules/sub-parts* in terms of *mass*, *materials* and *technologies*. Whereas, **Table 7** reports input/output flows used for the materials and technologies eco-profile modelling; only data about innovative materials/technologies are reported since mainly rely on primary data. The data related to PA410, glass fibre, carbon fibre, resins (epoxy and vinyl) and materials/technologies applied in the reference solutions are retrieved from GaBi database or literature.

**Table 1** FM input data

FM		Total mass (kg)	Materials mass (kg)	Materials	Technologies
(1) Crash management system	Ref	4.62	1.55 3.07	Aluminium High Strength Steel	Stamping and bending
	Light	3.55	1.40 1.93 0.14 0.09	Aluminium High Strength Steel CF PA410	Extrusion and Forming Thermoforming
	Mass variation ( $\Delta_{\text{mass}}$ )	-23%			
(2) Front longitudinal member	Ref	4.16	4.16	Aluminium	Deep drawing
	Light	4.01	3.37 0.40 0.27	Aluminium CF PA410	Extrusion, Airborne winding, Deep drawing and drilling

		Mass variation ( $\Delta_{\text{mass}}$ )	-4%		
(3) Strut dome and wheel housing	Ref	9.27	9.27	Steel	Deep drawing
	Light	5.63	1.73	Aluminium	Deep drawing and drilling, Thermoforming
			2.46	CF	
			1.64	PA410	
		Mass variation ( $\Delta_{\text{mass}}$ )	-40%		
(4) Front corner node	Ref	19.08	19.08	Steel	Deep drawing
	Light	10.79	1.21	Aluminium	Deep drawing and drilling, Bending, Thermoforming
			2.06	Steel	
			4.74	CF	
			3.16	PA410	
		Mass variation ( $\Delta_{\text{mass}}$ )	-43%		

**Table 2** FH input data

FH	Total mass (kg)	Materials mass (kg)	Materials	Technologies
Ref	11.54	11.54	Steel	Stamping and bending
Light	6.47	3.32	Aluminium	Metal stamping, Compression moulding
		2.21	CF	
		0.95	Epoxy resin	
Mass variation ( $\Delta_{\text{mass}}$ )	-44%			

**Table 3** FD input data

FD	Total mass (kg)	Materials mass (kg)	Materials	Technologies
Ref	9.24	9.10	Aluminium	Stamping and bending
		0.14	Steel	
Light	7.81	0.30	Aluminium	Metal stamping, CF-Airborne, Thermoforming
		4.73	CF	
		3.15	PA410	
Mass variation ( $\Delta_{\text{mass}}$ )	-16%			

**Table 4** CDB input data

CDB	Total mass (kg)	Materials mass (kg)	Materials	Technologies
Ref	10.00	10.00	Steel	Stamping and bending
Light	5.73	4.00	Aluminium	Metal stamping, Injection moulding, Thermoforming
		0.25	CF	
		0.67	GF	
		0.83	PA410	
Mass variation ( $\Delta_{\text{mass}}$ )	-43%			

**Table 5** SA input data

SA	Total mass (kg)	Materials mass (kg)	Materials	Technologies	
SA 1	4.00	4.00	Steel	Forging	
		1.15	Aluminium	Forging, RTM	
		0.36	CF		
			0.29	Epoxy resin	
Mass variation ( $\Delta_{\text{mass}}$ )	-55%				
SA 2	4.00	4.00	Steel	Forging	
		0.67	Aluminium	Forging, ASCM	
		0.60	CF		
			0.54	Vinyl Ester	
Mass variation ( $\Delta_{\text{mass}}$ )	-55%				

**Table 6** CFS input data

CFS	Total mass (kg)	Materials mass (kg)	Materials	Technologies
Ref	35.50	27.20	Aluminium	Deep drawing
		5.30	Steel HDG	
		3.00	Plastic	
Light	28.10	13.10	Aluminium	Deep drawing, cold rolling, Thermoforming
		2.90	Steel	
		7.26	GF	
		4.84	PA410	
Mass variation ( $\Delta_{\text{mass}}$ )	-21%			

**Table 7** Processes for each LC stage: source and quality of primary data

Materials/ technologies	Processes	Flows		Source
		Input	Output	
PA410-CF60 WT	UD Tape production Thermoplastic (CF)	<ul style="list-style-type: none"> <li>CF 0.63 kg</li> <li>PA410: 0.42 kg</li> <li>Electricity: 0.36÷1.08 MJ</li> </ul>	<ul style="list-style-type: none"> <li>UD CF: 1 kg</li> <li>Scrap: 0.05 kg</li> </ul>	Material supplier
	WT production Thermoplastic (CF)	<ul style="list-style-type: none"> <li>UD CF: 1.06 kg</li> <li>Electricity: 2.92 MJ</li> </ul>	<ul style="list-style-type: none"> <li>WT CF pre-preg: 1 kg</li> <li>Scraps: 0.06 kg</li> </ul>	Material supplier
PA410-CF60 stacked UD tape plies	UD Tape production Thermoplastic (CF)	<ul style="list-style-type: none"> <li>CF 0.63 kg</li> <li>PA410: 0.42 kg</li> <li>Electricity: 0.36÷1.08 MJ</li> </ul>	<ul style="list-style-type: none"> <li>UD CF: 1 kg</li> <li>Scrap: 0.05 kg</li> </ul>	Material supplier
	Stacked UD Tape plies (CF)	<ul style="list-style-type: none"> <li>UD CF: 1 kg</li> <li>Electricity: 0.36 MJ</li> </ul>	<ul style="list-style-type: none"> <li>Stacked UD 1 kg</li> </ul>	Material supplier
Epoxy resin CF70/65	UD Tape production Thermoset (CF)	<ul style="list-style-type: none"> <li>CF: 1.05 kg</li> <li>Resin: 0.02 kg</li> <li>Electricity: 1.58 MJ</li> </ul>	<ul style="list-style-type: none"> <li>UD CF: 1 kg</li> <li>Scrap: 0.05 kg</li> </ul>	Material supplier
	WT production Thermoset (CF)	<ul style="list-style-type: none"> <li>UD CF: 1.06 kg</li> <li>Electricity: 2.92 MJ</li> </ul>	<ul style="list-style-type: none"> <li>WT CF: 1 kg</li> <li>Scraps: 0.06 kg</li> </ul>	
	Pre-preg fibre Thermoset (WT fibre)	<ul style="list-style-type: none"> <li>WT CF: 0.7 kg</li> <li>Epoxy resin: 0.3 kg</li> <li>Electricity: 4.3 MJ</li> </ul>	<ul style="list-style-type: none"> <li>WT CF pre-preg: 1 kg</li> </ul>	Material supplier, [35]
	Pre-preg fibre Thermoset (WT fibre)	<ul style="list-style-type: none"> <li>WT CF: 0.65 kg</li> <li>Epoxy resin: 0.35 kg</li> <li>Electricity: 4.3 MJ</li> </ul>	<ul style="list-style-type: none"> <li>WT CF pre-preg: 1 kg</li> </ul>	Material supplier, [35]
Vinyl Ester CF53	Prepreg Fibre Thermoset (SCF)	<ul style="list-style-type: none"> <li>SCF: 0.53 kg</li> <li>Vinyl Ester: 0.47 kg</li> <li>Electricity: 4.3 MJ</li> </ul>	<ul style="list-style-type: none"> <li>CF pre-preg: 1 kg</li> </ul>	Manufacturer
Product Technologies	Advanced Sheet Compression Molding (ASCM)	<ul style="list-style-type: none"> <li>Pre-preg fibre: 1.01 kg</li> <li>Electricity: 7.09 MJ</li> </ul>	<ul style="list-style-type: none"> <li>Scraps: 0.01 kg</li> <li>Semi-worked part: 1 kg</li> </ul>	Manufacturer
	Forging (Al)	<ul style="list-style-type: none"> <li>Aluminum ingot: 1.08 kg</li> <li>Electricity: 1.15 MJ</li> </ul>	<ul style="list-style-type: none"> <li>Scraps: 0.08 kg</li> <li>Semi-worked part: 1 kg</li> </ul>	Manufacturer
	Airborne winding/CFP	<ul style="list-style-type: none"> <li>UD Tape: 1.05 kg</li> <li>Electricity: 2.98 MJ</li> </ul>	<ul style="list-style-type: none"> <li>Scraps: 0.05 kg</li> <li>Semi-worked part: 1 kg</li> </ul>	Manufacturer
Assembly	Composite spot welding	<ul style="list-style-type: none"> <li>Electricity: 0.045 MJ</li> </ul>	<ul style="list-style-type: none"> <li>Joined part: 1 pcs</li> </ul>	Manufacturer
	Adhesive Bonding	<ul style="list-style-type: none"> <li>Adhesive: 0.0059 kg</li> <li>Electricity: 0.233 MJ</li> </ul>	<ul style="list-style-type: none"> <li>Joined part: 1 m</li> </ul>	[36]

#### 4.2.2 Use stage

In the Use stage modelling the environmental impact due to each module mass, during its entire life time (150000 km), is estimated by correlating the variation in car mass between the scenarios of presence and absence of the module to the corresponding variation in energy consumption. As the mass-induced energy consumption over the World-wide harmonized Light duty Test Cycle (WLTC) is estimated around 0.69 kWh/100kg·100km [37], the energy consumption attributed to the module is calculated by the equation:

$$energy_{component} = \frac{\left(energy_{M1} \cdot \frac{mass_{component}}{100} \cdot \frac{use_{km}}{100}\right)}{eff_{battery} \cdot eff_{charger}} \quad (1)$$

Where:  $energy_{MI}$  is the mass-induced energy consumption [ $kWh/100kg*100km$ ];  $mass_{component}$  is the mass of the module [ $kg$ ];  $use_{km}$  is the life-distance [ $km$ ];  $eff_{battery}$  is the battery efficiency, assumed 85% [37];  $eff_{charger}$  is the charger efficiency, assumed 95% [37]. As for the electricity mix, the European average (2014) has been assumed and derived from GaBi.

Overall, when lightweighting is addressed, the evaluation of secondary effects related to vehicle/component mass reduction becomes a relevant point [22, 24, 25]. Overall secondary effects can be defined as the reduction of weight of other vehicle parts as a consequence of load changes, thus allowing energy/fuel reduction further to weight-saving effect while maintaining vehicle performance [22]. In particular, the powertrain adaptation and battery resizing are considered the most important secondary effects in the EVs case [24]. Currently, only few studies from literature consider secondary effects [38, 39, 40, 41]; moreover, a clear approach and mathematical model to evaluate secondary effects attributable to lightweighting of EVs component is not available on literature. Therefore, in this paper, it has been assumed to exclude secondary effects from the assessment since such topic would deserve a dedicated and in-depth analysis which was out of the scope of this study.

### 4.2.3 EoL stage

Two different scenarios are modelled for analysing impacts stemmed from the EoL stage (**Figure 11**):

- *Current*, which represents the existing EoL management system and consists of shredding and post-shredding technologies for materials recycling or, in case of the innovative solutions, energy recovery from Automotive Shredding Residue (ASR) [42];
- *Future*, which assumes that advanced post-shredding and recycling technologies would be adopted. For example, it was supposed the recycling of fibres by the pyrolysis process: this innovative technology allows separating fibres from resin (or matrix) using thermal energy in an oxygen-free environment [23, 26].

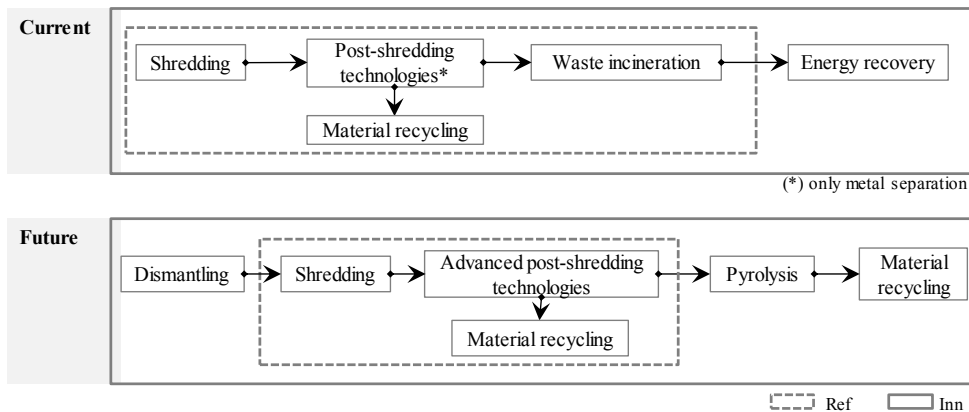

**Figure 11 EoL scenarios: flow charts for innovative components and reference ones**

Data source and quality about energy consumption of the technologies involved in vehicle EoL are reported in **Table 8**.

**Table 8** Processes for EoL stage: source and quality data

Process	Unit	Quantity	Source
Dismantling (e.g. tyres, bumpers, glass)	MJ/kg	0.07	Personal
Shredding (ferrous and no ferrous metals)	MJ/kg	0.18	communicat
Post-shredding technologies (based on Si-Con technology)	MJ/kg <sub>ASR</sub>	0.12	ions with
Pyrolysis	KJ/kg	10	project
Recycling of steel (aluminium auto wheels scrap credit)	%	47	partners
Recycling of aluminium (auto fragments scrap credit) (Current scenario)	%	42	[10]
Recycling of aluminium (aluminium auto wheels scrap credit) (Future scenario)	%	70	GaBi
Recycling of carbon fibres (Future scenario)	%	50	GaBi
Waste incineration (plastic) (Current scenario)	-	-	Assumption
			GaBi

## 5 Results and interpretation

The Life Cycle Impact Assessment (LCIA) is the basis for the last stage of the LCA (interpretation) because it represents the stage in which inventory data are converted into potential environmental impacts. The LCIA is performed according to the CML 2001 method; impact categories have been selected according to relevance perceived by partners (e.g. designers, materials suppliers) involved in the ENLIGHT project and literature statements [19, 30]. Therefore, results are reported according to the following impact categories: Global Warming Potential (GWP), expressed in kg CO<sub>2</sub>-eq.; Eutrophication Potential (EP), expressed in kg Phosphate-eq.; Ozone Depletion Potential (ODP), expressed in kg R11-eq.; Photochemical Ozone Creation Potential (POCP), expressed in kg Ethene-eq.; Abiotic Depletion Potential elements (ADP<sub>el</sub>), expressed in kg Sb-eq.. Additionally, the Primary Energy Demand (PED), expressed in MJ, is calculated. GaBi software is used for modelling and implementing the LCA analysis.

Afterwards, results interpretation is performed according to the four-level approach described in chapter 2.

### 5.1 Level 1: LC stages contribution

A first level of LCA results interpretation concerns the analysis of the contribution of each LC stage to the selected environmental impact categories (GWP; EP; OPD; POCP; ADP<sub>el</sub>; PED) and the two EoL scenarios (*Current* and *Future*).

In particular, in the following bar charts (Figure 12, Figure 13, Figure 14, Figure 15, Figure 16, Figure 17) it can be observed the relationship between the mass of each component and the corresponding impact: there is a direct proportionality; for example CFS component, which is the biggest in terms of mass, causes the highest impact. For this reason, there is a graph flattening in case of those components characterized by a smaller mass (i.e. SA).

Besides an overall consistent mass reduction, ranging between 16% and 55%, the lightweight solutions are not able to provide benefits, in terms of GWP, with the exception of the CDB and CFS cases. This is mainly due to the increase of the production stage impacts which overcomes benefits achieved in the use stage; this confirming the trade-off between use stage and material production step in accordance to studies from literature [18]. The EoL stage was found negligible when the landfill disposal is involved, while the energy recovery from the final incineration and the materials recycling make this stage relevant, in some cases influencing the comparison with the reference solution.

The analysis of the other impact categories confirms the trade-off between LC stages which results in an overall worsening with the exception of CDB, SA1, SA2 and CFS. However, the results reveal that the various impact categories have different behaviours; in fact, in some case the lightweight solutions could provide improvements in terms of impact categories different from the GWP. This demonstrates the importance of extending the environmental assessment to a diverse set of impact categories.

A focus on the EoL stage shows that: i) impacts due to energy consumption for final treatment (e.g. shredding) are generally negligible; ii) in some case the impacts (in terms of avoided burdens) from the final treatment could influence the overall life cycle impact and the final comparison with the reference solution in a considerable way. Moreover, the benefit achieved from advanced post-shredding treatment, and the following fibres recycling (future scenario) could be higher than the energy recovery process (current scenario).

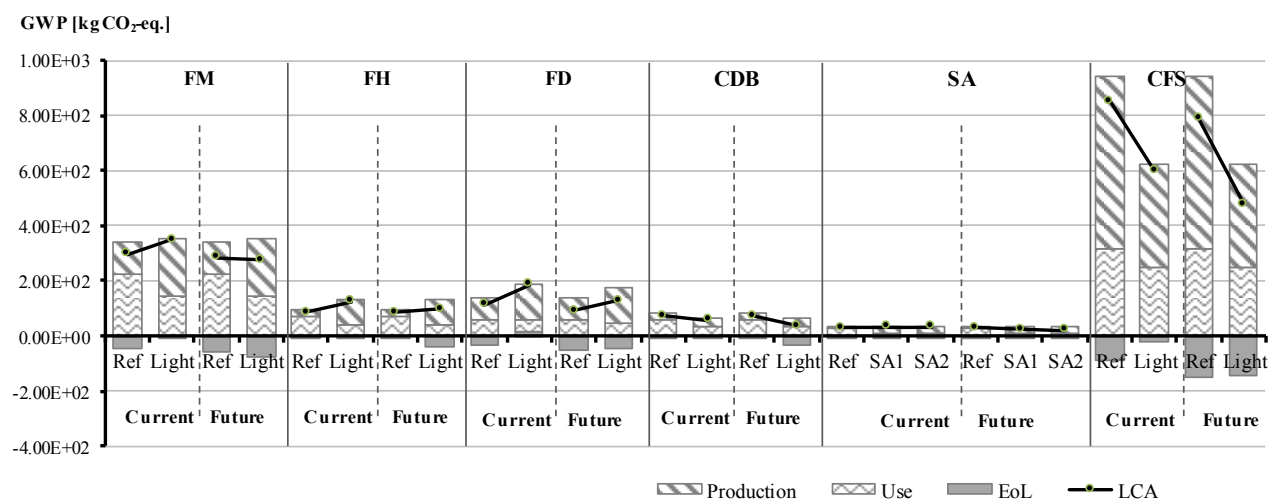

Figure 12 Results of GWP [kg CO<sub>2</sub>-eq.] impact assessment

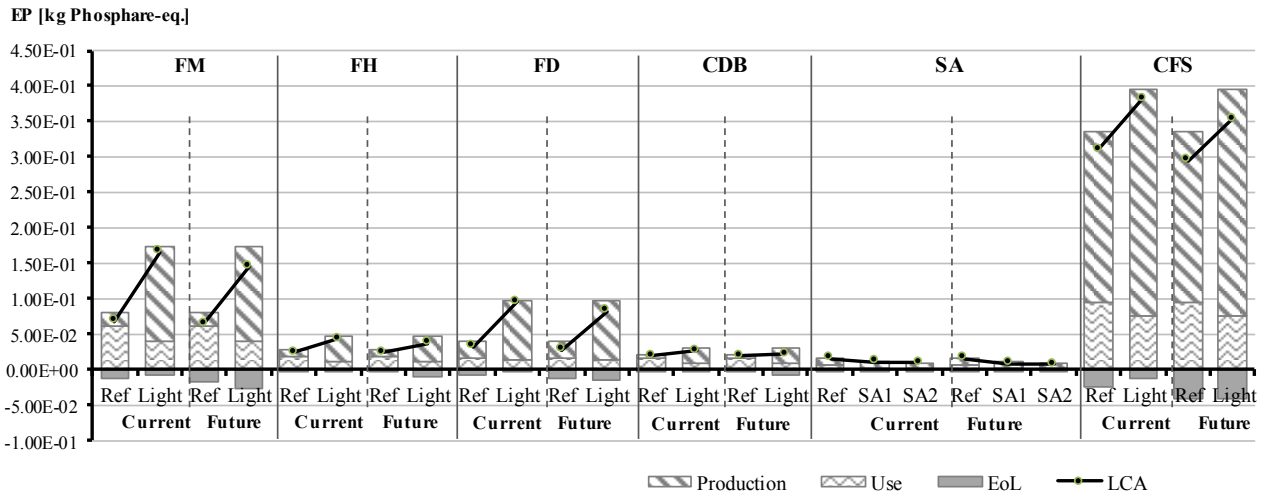

Figure 13 Results of EP [kg Phosphate-eq.] impact assessment

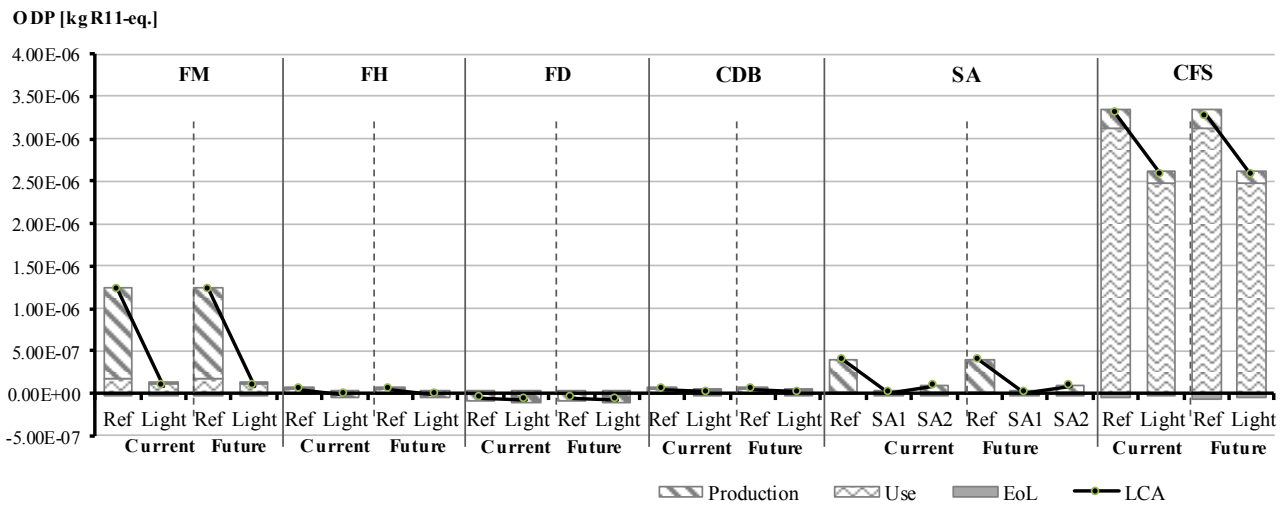

Figure 14 Results of ODP [kg R11-eq.] impact assessment

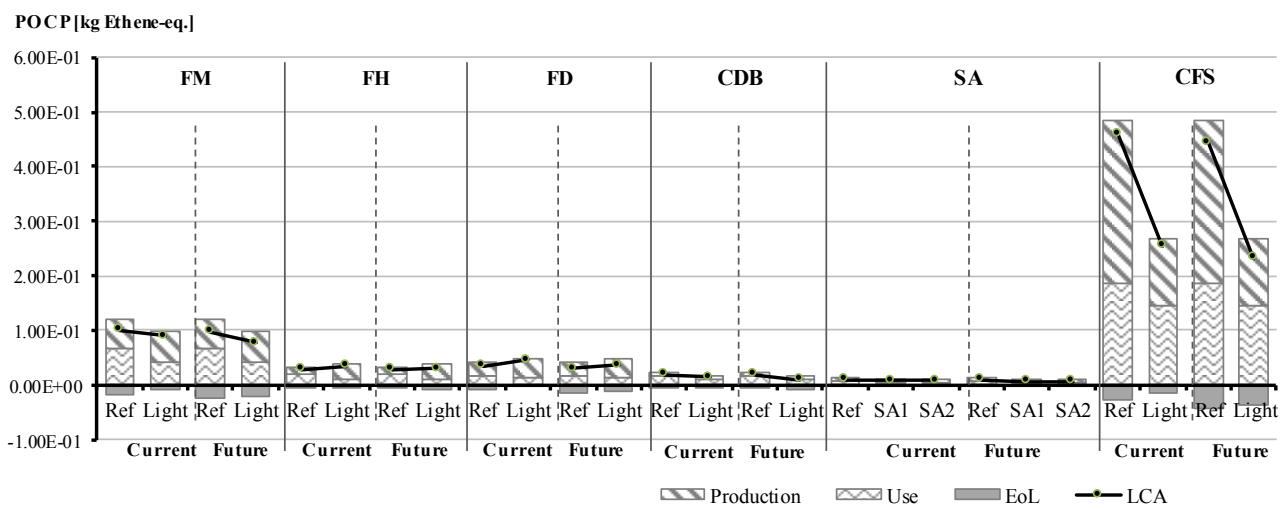

Figure 15 Results of POCP [kg Ethene-eq.] impact assessment

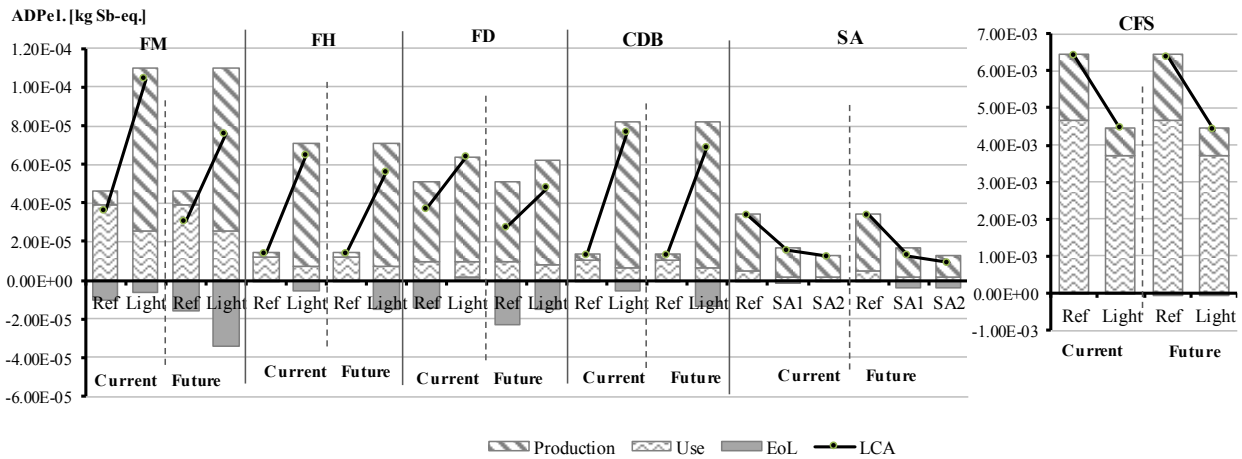

Figure 16 Results of  $ADP_{el}$  [kg Sb-eq.] impact assessment

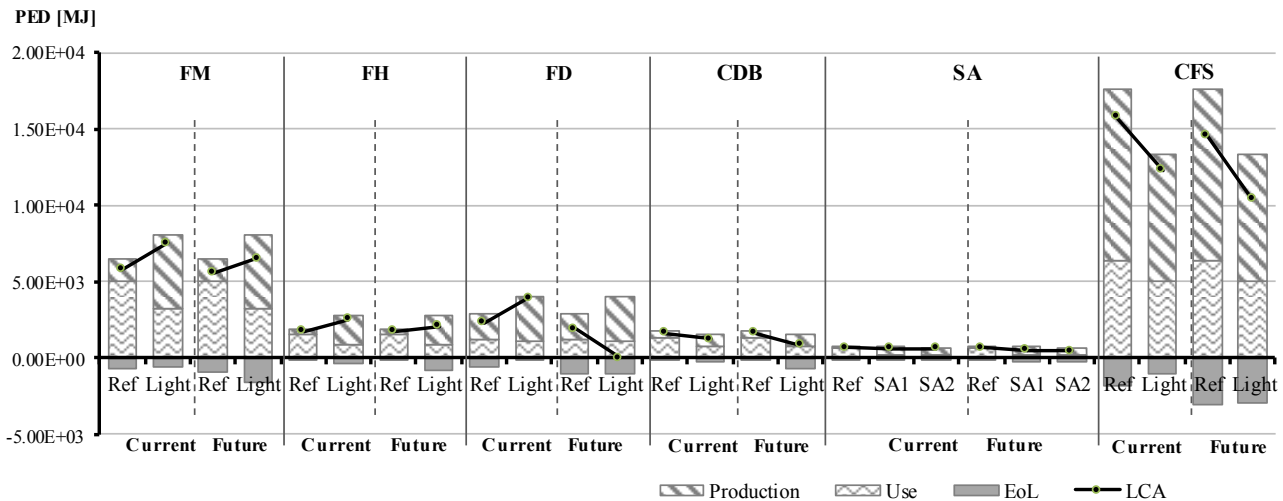

Figure 17 Results of PED [MJ] impact assessment

## 5.2 Level 2: Focus on Production stage

The LCA outcomes show that the *Production stage* plays an important role in the entire LC impact assessment; for this reason, further investigations at *component level* and *material level* are carried out. Among the examined impact categories, three impact categories - GWP,  $ADP_{el}$  and PED – have demonstrated a different trend, so further results interpretation is focused on them as a way to better monitor the trade-off between production and use stage.

### 5.2.1 Component level

Among the six considered modules, a special attention is given to FH and FD as mostly representative of the innovative materials application. The following bar charts illustrate a focus on the environmental impact of materials types within the *Production stage*; the results are in comparison with reference ones (Figure 18, Figure 19). Concerning FH, the graphs in Figure 18 show that the steel-based reference solution is preferable than the innovative one for all of each impact category, despite the lower mass (-44%). The hybrid lightweight solution is composed for around 51% of its mass of aluminium and 48% of thermoset composite; however, the higher impact in the production stage is mainly due to the last one. In particular, the production of carbon fibre is the main responsible because it is particularly energy demanding. In addition, the assumption of primary aluminium use generates high impact, although its small amount. Primary aluminium has been generally abandoned in the current automotive practice, however the lack of specifications about aluminium within the project mainly guided such assumption. The use of different aluminium alloys certainly is expected to be beneficial in the whole life cycle impact. At the same time, it is well known that steel and aluminium can be recycled indefinitely and it is part of a partial closed-loop economy related to generation and reuse of scraps. This

means that the collection and treatment of scraps to turn it into true secondary raw materials competing with virgin ones produce relevant benefits during the EoL stage, in terms of credits, even as current scenario.

In **Figure 19** the impacts of FD materials are reported. Also in this case the reference solution (made of aluminium) is preferable than the innovative one; nevertheless, a smaller gap between the two production stages is found and this is due to two main reasons. First, the environmental impact produced by aluminium production is large particularly due to raw materials extraction; secondly, the PA410 (70% bio-based) allows reducing impacts at least in terms of GWP.

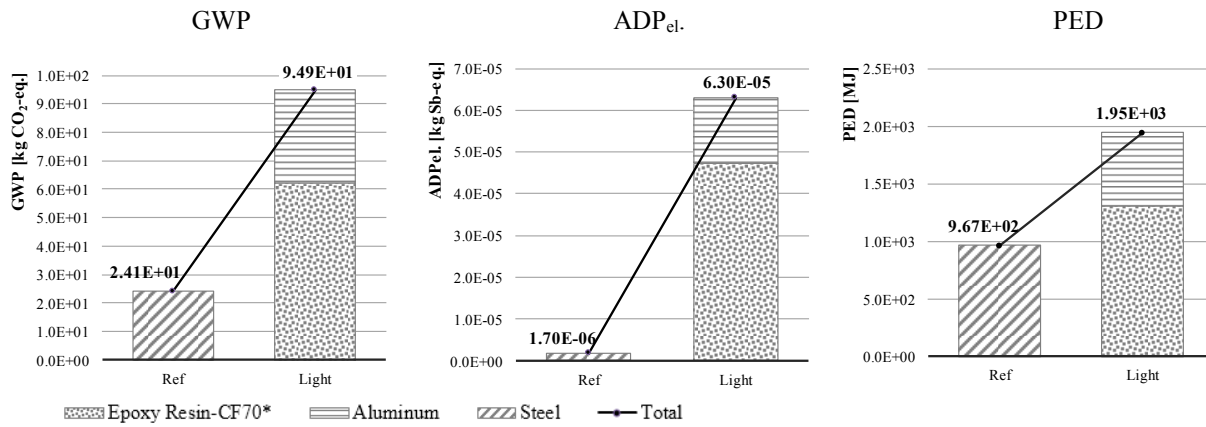

**Figure 18** Impact assessment: production stage of FH

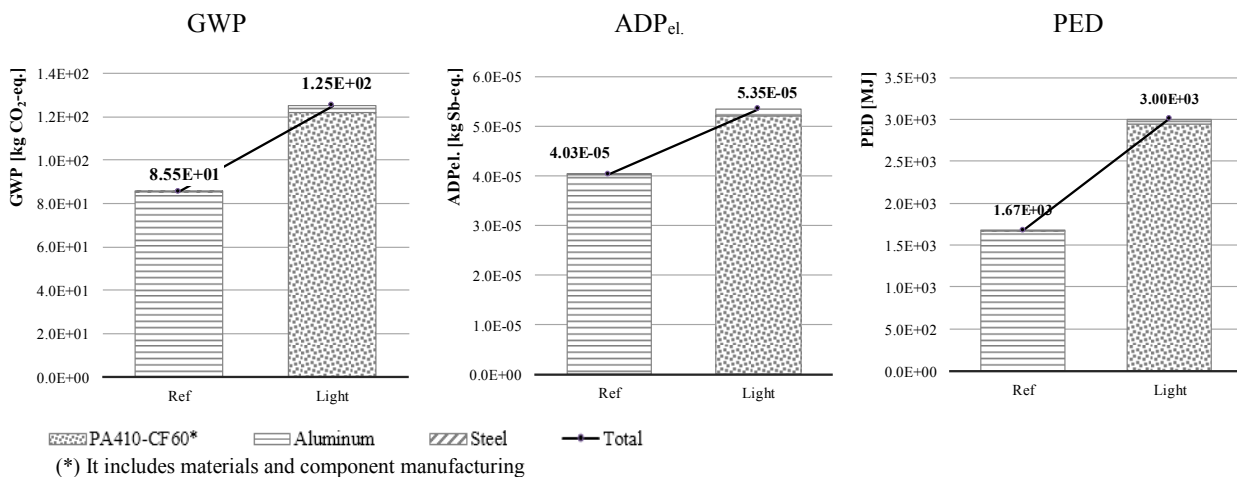

**Figure 19** Impact assessment: production stage of FD

### 5.2.2 Material level

Overall, the materials processing represents the main contribution in the production stage, for this reason a further breakdown is carried out concerning the innovative materials. The environmental impacts (in terms of GWP, ADP<sub>el</sub> and PED) generated by 1 kg of the following materials are evaluated: PA410-CF60 WT, PA410-CF60 stacked UD tape plies, Epoxy Resin-CF70 WT and Vinyl Ester-CF53.

The outcomes suggest that carbon fibre production plays the main role especially in the GWP and PED values; resin and matrix production follow (**Figure 20**, **Figure 21**, **Figure 22**, **Figure 23**). The impacts stemmed from the additional technologies for the fibres processing (e.g. UD Tape/spread tow production, weaving) are generally negligible.

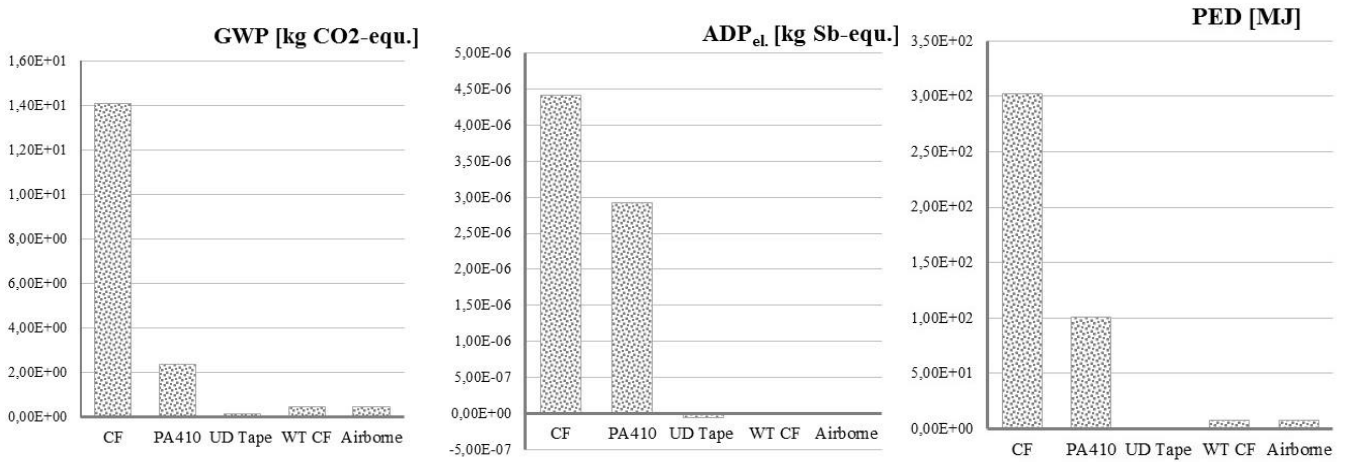

Figure 20 Impacts Assessment of PA410-CF60 WT: ADP<sub>el.</sub>, GWP and PED results

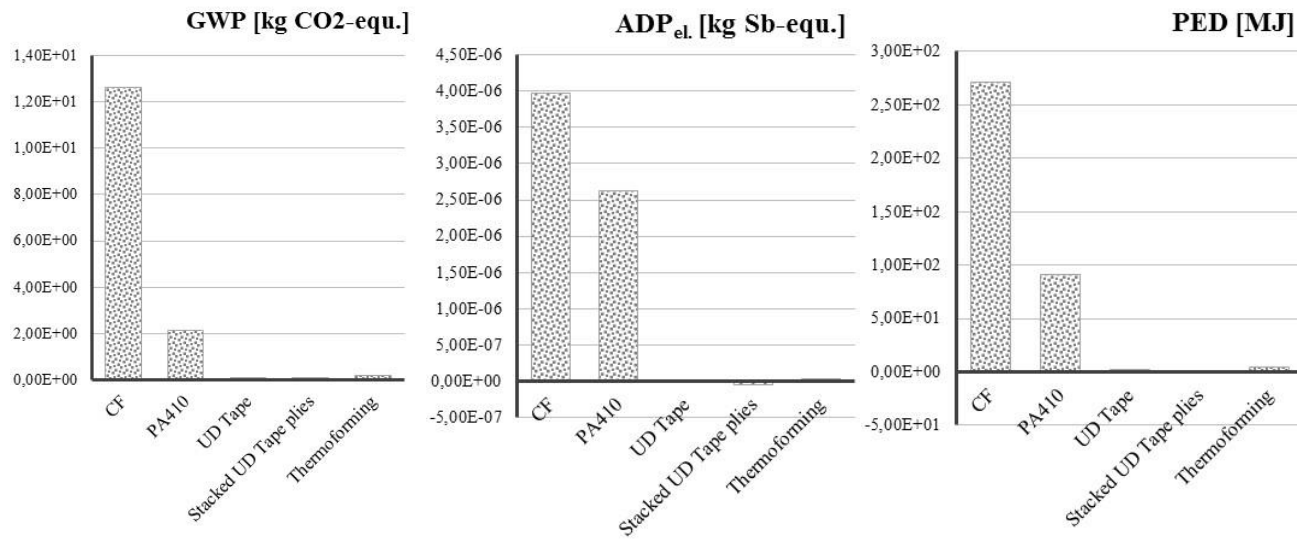

Figure 21 Impacts Assessment of PA410-CF60 stacked UD tapes plies: ADP<sub>el.</sub>, GWP and PED results

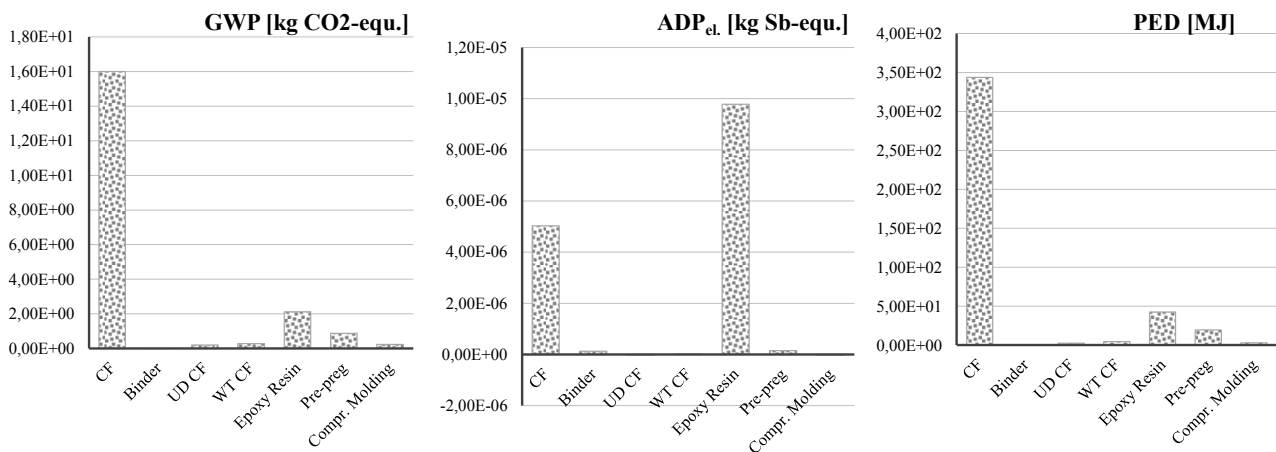
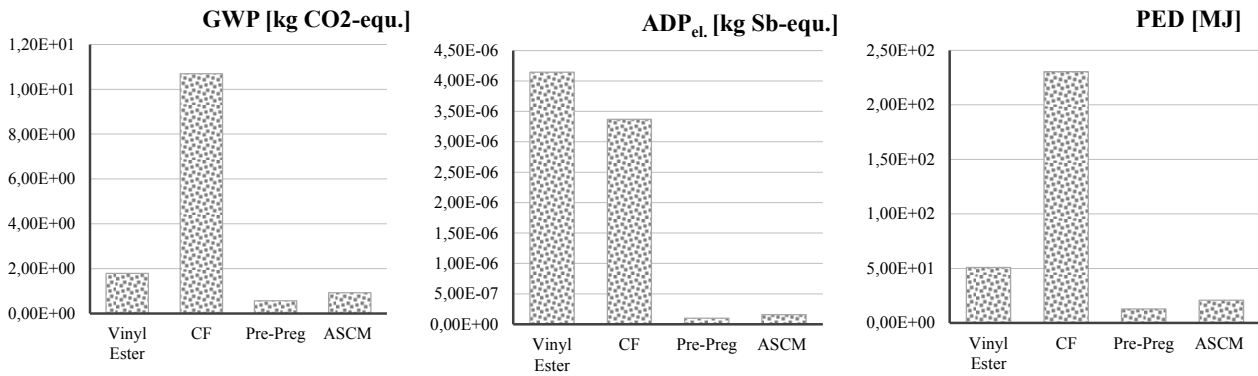

Figure 22 Impacts Assessment of Epoxy Resin CF70 WT: ADP<sub>el.</sub>, GWP and PED results



**Figure 23** Impacts Assessment of Vinyl Ester CF53: ADP<sub>el</sub>, GWP and PED results

A different trend is observed for ADP<sub>el</sub>. [43, 44], in fact, in this case the role of matrix and resin production oppose the prevailing contribution of CF, which is even overcome in the case of thermoset-based composite (epoxy and vinyl ester).

Although ADP<sub>el</sub> is the impact category recommended in the ILCD framework [33] to detect impacts in terms of resources depletion according to their scarcity, few literature exists concerning the environmental consequences of composites in terms of raw material extraction, according to such category. The awareness about its interpretation is still lower than other categories and specific initiatives currently exist at European level to improve the robustness of this category [45]. From this study, it emerged that chromium, cobalt, magnesite, manganese and gallium have the highest contribution in the ADP<sub>el</sub> values of CF, Epoxy resin and PA410 production process according to the GaBi database. However, such list is representative for the complete material production process and it should not be interpreted as elementary flows list of the materials. Their relationship with energy and auxiliaries' amounts could be argued, however it is currently not possible to have more insights.

### 5.3 Level 3: Break-even point

The third level of results interpretation is carried out by means of the break-even point (BP) analysis with the aim of providing insights about the relationship of GWP results with some design aspects. A BP value is acceptable when it is lower than the vehicle life span (assumed 150000 km); the higher is the BP the lower are the benefits produced by the lightweight solution. When the BP presents a negative value this means that the lightweight solution is better than the reference since the beginning of the analysis (at the *Production stage*).

#### 5.3.1 Break-even point in EV

In this first case, the break-even point between reference and lightweight solutions was calculated for each component when it is mounted over the EV and by considering the two EoL scenarios. **Figure 24** shows the relationship between BP values, the achieved delta mass and the EoL scenarios.

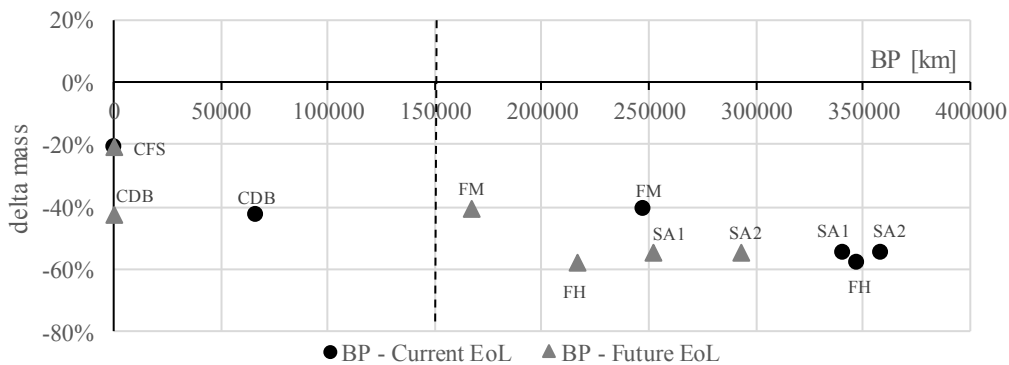

**Figure 24** Relationships between delta mass, break-even point and EoL scenarios for each component

It can be observed that only two components (CDB and CFS) have a BP lower than the vehicle life span; in the CFS case the break-even point was negative (in the graph it is set zero in order to improve readability of results) thus confirming that the lightweight solution is overall better than the reference one. In the case of FM and FH the break-even analysis is particularly influenced by the EoL scenario, in fact, when the future scenario is assumed then the BP is in favour of the new solution. Overall, a relationship between delta mass and the BP values is not observed; on the contrary, the inclusion of the EoL stage and the assumptions regarding a certain scenario are responsible for a no negligible effect on the break-even analysis. Although the EoL stage is generally not addressed in the break-even point analysis [30], [34], however, these results demonstrate that its inclusion is particularly important in order to provide comprehensive outcomes. Detailed BPs values are reported in Appendix B.

### 5.3.2 Break-even point in EV vs. ICEV

The LCA results reported until now suggest that the innovative materials with such a high impact in the production stage could not be suitable in the case of EVs where the emission rate in the use stage is generally low if compared to traditional vehicle one. For this reason, the break-even analysis is carried out also in the case of Internal Combustion Engine Vehicle (ICEV), by assuming that all the studied modules could fit an ICEV architecture without significant changes in materials masses. The use stage of ICEV case was modelled assuming the 1.4 l 125 cv gasoline Golf VI (EURO 6) as reference vehicle; therefore, fuel consumption and CO<sub>2</sub> emissions have been calculated according to the formulation of paragraph 4.2.2 which was properly modified for the ICEV case according to the model proposed by Delogu et al. [16]. The mass-induced fuel consumption is assumed 0.166 kWh/100kg\*100km [22]; the life-distance is set to 150000 km; CO<sub>2</sub>, SO<sub>2</sub> emissions and fuel consumption of vehicle are 120 g/km 2.46 10<sup>-7</sup> g/km and 5.2 l/100km respectively.

The BP values of the ICEV case are then compared to the ones obtained in the EV case (paragraph 5.3.1) (**Figure 25**). For all the components, BP values are lower in the ICEV case and this result is mostly driven by the different emissions rate of the ICEV use stage with respect to the EV one: 7.43 kg CO<sub>2-eq</sub>/kg<sub>comp</sub> and 6.05 kg CO<sub>2-eq</sub>/kg<sub>comp</sub> respectively. These findings stress that the adoption of the studied lightweight solutions is preferable in the ICEV case; however, the comparison between reference and lightweight solutions is not reversed. In fact, the impacts of the production stage are still too high to be balanced by the use stage benefits in the majority of modules.

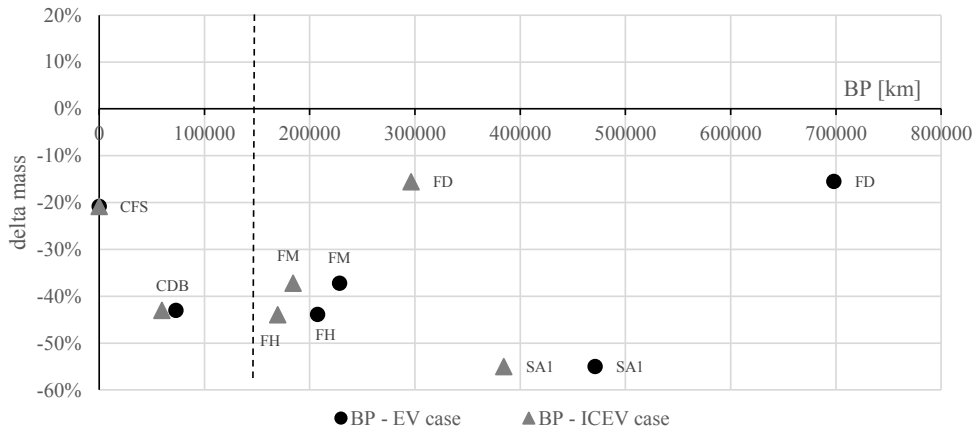

**Figure 25** Comparison between break-even point values in the EV case and ICEV case for each module

### 5.4 Level 4: Performance indicator

Overall the different impact categories showed a different behaviour so, to better investigate this aspect, a performance indicator, relating the differences in terms of impact and mass, was calculated by means of the equation (2). In particular, this indicator was examined for the three impact categories - GWP, PED, ADP<sub>el</sub> - to evaluate the relationships with three design aspects: mass reduction, EoL and material pairs. When this indicator is >0 it means that the lightweight solution provides improvements, whereas when it is <0 then it does not.

$$\Delta_{I/M}^P = \frac{\Delta_{impact}}{\Delta_{mass}} = \frac{impact_{LC Ref.} - impact_{LC Light}}{mass_{Ref.} - mass_{Light}} \quad (2)$$

First the link between delta mass,  $\Delta_{I/M}^P$  (GWP, ADP<sub>el.</sub>, PED) and EoL scenarios for each module is analysed (**Figure 26**). The results show that a relationship between mass reduction value (delta mass) and performance indicators values cannot be observed, whereas the EoL scenarios is confirmed to influence particularly GWP and PED values. In fact, for some modules (FM, SA1, SA2 and FH) the adoption of the Future EoL scenario, characterized by a higher material recycling rate, makes the performance indicator gain a positive score.

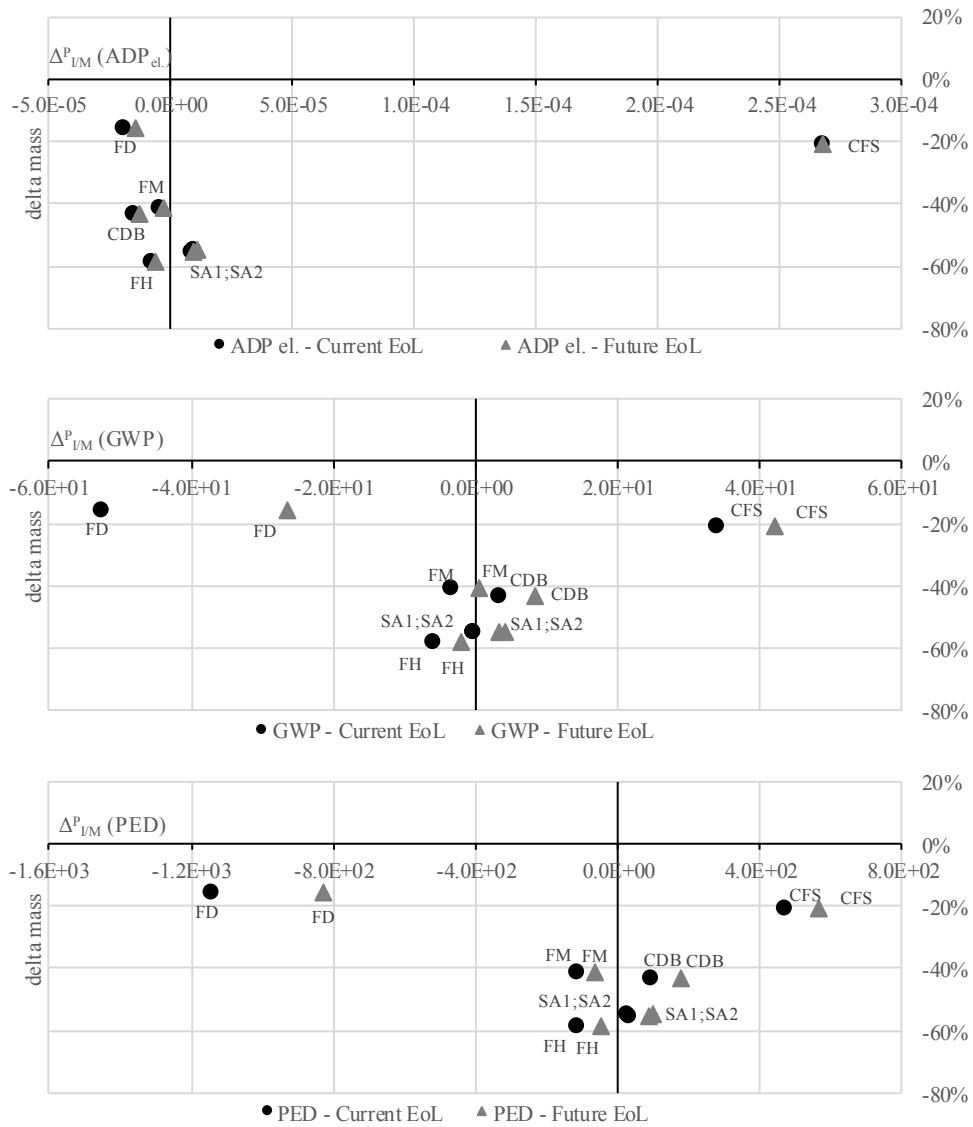

**Figure 26** Relationship between delta mass,  $\Delta_{I/M}^P$  (GWP, ADP<sub>el.</sub>, PED) and EoL scenarios for each component

The material pairs can be considered another significant element; in all the studied modules steel, or aluminium, is replaced by a hybrid solution made with metal parts (generally aluminium) and composite elements. The composite quantity is certainly a hotspot, so two material pairs classes could be identified - Metal-to-Composite (<50%ww) and Metal-to-Composite (>50%ww) – where the composite rate is the discriminating element. The modules belonging to the first class are FM, CDB, SA1, FH and CSF. While lightweight solutions of SA2 and FD include a composite amount higher than 50% of the total component mass. The analysis of the relationship between material pair class and performance indicators suggests that when the design changes from a metal-based solution to a hybrid solution the outcome is found more uncertain and it is not possible to expect benefit a priori. Moreover, those modules characterized by a composite rate <50% provide performance indicators values generally better than the ones with a higher composite content; therefore, it can be argued that the higher composite amount the more uncertain is the final environmental benefit. Detailed figures about performance indicators values and material pairs are reported in Appendix B.

## 6 Conclusions

Most of the scientific articles published so far have addressed the life cycle impacts of lightweight materials in the ICEVs design, or the achievable environmental advantages of EVs over traditional vehicles. This paper deals with the environmental assessment, by means of LCA, of lightweight solutions applied to EVs components thus contributing to the advancement of knowledge in this field as a recent topic and a subject of interest to the current literature; lightweight EVs is expected, indeed, to combine advantages of both vehicles electrification and lightweight design. In particular, the studied solutions are based on composites and hybrid materials whose high mass reduction potential is expected to be particularly profitable in the EVs case. The environmental assessment compared such lightweight solutions to the corresponding reference ones, by assuming no changes in the powertrain system. The main findings concern: i) a detailed LCA of real lightweight solutions for six EVs modules; ii) the primary data collection to build eco-profiles of innovative materials not present in the current database; iii) the identification and application of a four-level scheme to interpret LCA results in a clear and complete manner.

Data used in this study were originated in the EU-project ENLIGHT; in particular, information about modules designs (e.g. geometries, masses) and primary data about energy, raw materials and scraps characterizing the materials processing and manufacturing were collected. Data collection regarded four innovative carbon-based and glass-based materials incorporating PA410 and traditional resins, and involving different reinforcement solutions (chopped fibres, stacked UD tapes plies and stacks of spread-tow Woven Tapes).

The interpretation of LCA results is a very important stage because it allows identifying the relationship between impacts and choices in the design phase. The four-level approach proposed in this paper was found a suitable way to analyse and present results in a clear and complete manner. The analysis of the LC stages contributions (Level 1) showed that the use of the innovative materials enables relevant mass reduction (between 16% and 55%) but it could ensure environmental benefits, over the metal-based solutions, only in two of the studied modules. The main reason is the large impact from the production stage of the new materials, which outweighs the advantages in the use stage. Overall, the results interpretation confirmed the existence of two main trade-offs: the first between benefits in the use stage and increased impacts in the production stage; the second between the different impact categories. As for the evaluation of the different impact categories, outcomes from this paper showed that  $ADP_{el}$  generally had a different trend if compared to GWP and PED; therefore, further results interpretation was focused on these categories. Focus on impacts from production stage (Level 2) stressed that material processing is the largest contribution in all the impact categories, in particular matrix- and resin-based composites. Along the composite production process, carbon fibres are the main responsible of impacts, whereas the energy consumed in the several processes for the reinforcement production (e.g. UD tape and WT production) were found negligible. The break-even analysis (Level 3) between reference and lightweight solutions in the EVs case stressed that only two components have a BP lower than the vehicle life span (150000 km). This suggests that generally the high impact in the production stage makes the studied innovative material not suitable for EVs. Then, the break-even points were also calculated in the ICEV case by assuming that the lightweight solution could be suitable also for a traditional vehicle architecture. In this case, the BP values became smaller thus stressing that those materials could provide more benefit in this last case. The different emission rate of the use stage is the main reason of that result; however, the comparison between reference and lightweight solutions is not reversed. Further conclusions could be drawn by means of the performance indicators that relates differences in terms of impact and mass (Level 4); the EoL scenario and material pairs were found the elements mostly affecting results, among the analysed ones. For some modules, the adoption of the Future EoL scenario, characterized by a higher material recycling rate, makes the performance indicator gain a positive score. Moreover, when the design changes from a metal-based solution to a hybrid solution the outcome is found more uncertain and particularly sensitive to the composite rate.

Due to the high relevance in the life cycle impacts of composite-based solutions, an in depth analysis could regard processes for fibres production as way to identify hotspot and suggest improvements. In addition, the inclusion of more specific aluminium alloys in the environmental modelling could provide results more realistic, perhaps in favour of the studied lightweight designs. Including secondary effects in the use stage modelling could allow evaluating benefits from lightweight more precisely; therefore, investigation should regard mass-induced energy consumption values that include also secondary effect. In the light of better evaluating the influence of lightweight materials on the resource depletion, further work could regard interpretation of  $ADP_{el}$  also by evaluating the relationship with technologies/processes parameters.

## **Acknowledgements**

The presented work was funded by the European Commission within the project ENLIGHT (Grant agreement No: 314567): [www.project-enlight.eu](http://www.project-enlight.eu). The authors, as partners of the project, wish to thank all ENLIGHT partners for their contribution, particularly: Jaguar Land Rover, Magneti Marelli, Fraunhofer LBF, Airborne, DSM, Oxeon, CRF, BENTELER, Ika and Swerea.

## Appendix A: Tables LCA results

**Table A.1** Global Warming Potential (GWP) results: comparison with the reference solution

GWP (kg CO <sub>2</sub> -eq.)		Production	Assembly	Use	EoL		LCA	
					Current	Future	Current	Future
FM	Ref	1.18E+02	-	2.24E+02	-4.60E+01	-5.89E+01	2.96E+02	2.83E+02
	Light	2.05E+02	4.98E-01	1.45E+02	-3.28E+00	-7.65E+01	3.47E+02	2.74E+02
FH	Ref	2.41E+01	3.56E-02	6.98E+01	-9.87E+00	-9.87E+00	8.41E+01	8.41E+01
	Light	9.49E+01	3.52E-01	3.91E+01	-9.95E+00	-3.67E+01	1.24E+02	9.77E+01
FD	Ref	8.55E+01	4.11E-02	5.59E+01	-3.07E+01	-5.15E+01	1.11E+02	8.99E+01
	Light	1.25E+02	2.34E-01	4.72E+01	1.35E+01	-4.50E+01	1.86E+02	1.28E+02
CDB	Ref	2.02E+01	2.74E-02	6.05E+01	-8.55E+00	-8.55E+00	7.22E+01	7.22E+01
	Light	3.33E+01	0	3.45E+01	-1.02E+01	-3.24E+01	5.76E+01	3.54E+01
SA	Ref	5.86E+00	-	2.84E+01	-3.42E+00	-3.42E+00	3.08E+01	3.08E+01
	SA1	2.41E+01	-	1.09E+01	-2.58E+00	-1.02E+01	3.24E+01	2.48E+01
	SA2	2.11E+01	-	1.10E+01	-4.49E-02	-1.04E+01	3.21E+01	2.17E+01
CFS	Ref	6.24E+02	-	3.16E+02	-8.83E+01	-1.50E+02	8.52E+02	7.90E+02
	Light	3.74E+02	-	2.50E+02	-2.31E+01	-1.46E+02	6.01E+02	4.78E+02

**Table A.2** Eutrophication Potential (EP) results: comparison with the reference solution

EP (kg Phosphate-eq.)		Production	Assembly	Use	EoL		LCA	
					Current	Future	Current	Future
FM	Ref	1.93E-02	0	6.14E-02	-1.32E-02	-1.65E-02	6.75E-02	6.42E-02
	Light	1.33E-01	2.83E-04	3.97E-02	-7.79E-03	-2.76E-02	1.65E-01	1.45E-01
FH	Ref	7.87E-03	9.77E-06	1.91E-02	-3.07E-03	-3.07E-03	2.39E-02	2.39E-02
	Light	3.62E-02	2.91E-04	1.07E-02	-3.87E-03	-1.02E-02	4.33E-02	3.70E-02
FD	Ref	2.46E-02	1.13E-05	1.53E-02	-7.82E-03	-1.31E-02	3.21E-02	2.69E-02
	Light	8.39E-02	1.92E-04	1.29E-02	-1.09E-03	-1.43E-02	9.59E-02	8.27E-02
CDB	Ref	5.23E-03	7.52E-06	1.65E-02	-2.66E-03	-2.66E-03	1.91E-02	1.91E-02
	Light	2.07E-02	0	9.43E-03	-3.61E-03	-8.88E-03	2.65E-02	2.13E-02
SA	Ref	9.39E-03	0	7.76E-03	-1.06E-03	-1.06E-03	1.61E-02	1.61E-02
	SA1	8.40E-03	0	2.98E-03	-1.05E-03	-2.85E-03	1.03E-02	8.53E-03
	SA2	7.06E-03	0	3.00E-03	-7.00E-04	-3.07E-03	9.36E-03	6.99E-03
CFS	Ref	2.40E-01	0	9.49E-02	-2.45E-02	-4.02E-02	3.10E-01	2.95E-01
	Light	3.20E-01	0	7.51E-02	-1.33E-02	-4.20E-02	3.82E-01	3.53E-01

**Table A.3** Ozone Depletion Potential (ODP) results: comparison with the reference solution

ODP (kg R11-eq.)		Production	Assembly	Use	EoL		LCA	
					Current	Future	Current	Future
FM	Ref	1.08E-06	0	1.67E-07	-8.34E-09	-1.45E-08	1.23E-06	1.23E-06
	Light	-1.56E-09	1.77E-09	1.08E-07	-1.36E-08	-1.82E-08	9.47E-08	9.01E-08
FH	Ref	1.83E-09	2.64E-11	5.20E-08	2.76E-10	2.76E-10	5.41E-08	5.41E-08
	Light	-3.25E-08	1.47E-09	2.91E-08	-7.74E-09	-1.21E-08	-9.68E-09	-1.40E-08
FD	Ref	-8.48E-08	9.67E-10	3.52E-08	-3.74E-09	-3.40E-09	-5.23E-08	-5.20E-08
	Light	-1.04E-07	9.67E-10	3.52E-08	-3.74E-09	-3.40E-09	-7.17E-08	-7.14E-08
CDB	Ref	9.61E-09	2.03E-11	4.50E-08	2.39E-10	2.39E-10	5.49E-08	5.49E-08
	Light	4.69E-09	0	2.57E-08	-7.12E-09	-1.13E-08	2.33E-08	1.91E-08
SA	Ref	3.77E-07	0	2.11E-08	9.57E-11	9.57E-11	3.98E-07	3.98E-07
	SA1	8.90E-10	0	8.10E-09	-2.11E-09	-3.30E-09	6.88E-09	5.69E-09
	SA2	8.83E-08	0	8.16E-09	-1.56E-09	-2.20E-09	9.49E-08	9.43E-08
CFS	Ref	2.18E-07	0	3.13E-06	-4.32E-08	-7.27E-08	3.30E-06	3.28E-06
	Light	1.42E-07	0	2.47E-06	-2.61E-08	-3.93E-08	2.59E-06	2.57E-06

**Table A.4** Photochemical Ozone Creation Potential (POCP) results: comparison with the reference solution

POCP (kg Ethene-eq.)		Production	Assembly	Use	EoL		LCA	
					Current	Future	Current	Future
FM	Ref	5.38E-02	0	6.59E-02	-1.92E-02	-2.26E-02	1.00E-01	9.70E-02
	Light	5.70E-02	1.94E-04	4.26E-02	-9.51E-03	-2.19E-02	9.03E-02	7.79E-02
FH	Ref	1.28E-02	1.05E-05	2.05E-02	-5.21E-03	-5.21E-03	2.81E-02	2.81E-02
	Light	2.70E-02	1.57E-04	1.15E-02	-4.07E-03	-9.21E-03	3.46E-02	2.94E-02
FD	Ref	2.65E-02	1.21E-05	1.64E-02	-8.12E-03	-1.36E-02	3.48E-02	2.93E-02
	Light	3.28E-02	1.04E-04	1.39E-02	-1.32E-03	-1.03E-02	4.55E-02	3.65E-02
CDB	Ref	6.16E-03	8.05E-06	1.77E-02	-4.51E-03	-4.51E-03	1.94E-02	1.94E-02
	Light	8.08E-03	0	1.01E-02	-3.78E-03	-8.17E-03	1.44E-02	1.00E-02
SA	Ref	3.87E-03	0	8.32E-03	-1.80E-03	-1.80E-03	1.04E-02	1.04E-02
	SA1	6.50E-03	0	3.19E-03	-1.10E-03	-2.56E-03	8.59E-03	7.13E-03
	SA2	5.68E-03	0	3.22E-03	-7.53E-04	-2.50E-03	8.15E-03	6.40E-03
CFS	Ref	3.01E-01	0	1.85E-01	-2.63E-02	-4.26E-02	4.60E-01	4.43E-01
	Light	1.23E-01	0	1.46E-01	-1.46E-02	-3.67E-02	2.54E-01	2.32E-01

**Table A.5** Abiotic Depletion Potential (ADP<sub>et</sub>) results: comparison with the reference solution

ADP <sub>et</sub> (kg Sb eq.)		Production	Assembly	Use	EoL		LCA	
					Current	Future	Current	Future
FM	Ref	7.05E-06	0	3.93E-05	-1.03E-05	-1.61E-05	3.61E-05	3.03E-05
	Light	8.39E-05	7.99E-07	2.54E-05	-6.04E-06	-3.43E-05	1.04E-04	7.58E-05
FH	Ref	1.70E-06	4.37E-07	1.22E-05	-5.72E-07	-5.72E-07	1.38E-05	1.38E-05
	Light	6.30E-05	9.19E-07	6.86E-06	-5.90E-06	-1.50E-05	6.49E-05	5.58E-05
FD	Ref	4.03E-05	5.04E-07	9.80E-06	-1.39E-05	-2.33E-05	3.67E-05	2.73E-05
	Light	5.35E-05	6.03E-07	8.28E-06	1.51E-06	-1.48E-05	6.39E-05	4.76E-05
CDB	Ref	2.45E-06	3.36E-07	1.06E-05	-4.96E-07	-4.96E-07	1.29E-05	1.29E-05
	Light	7.59E-05	0	6.04E-06	-5.67E-06	-1.34E-05	7.62E-05	6.85E-05
SA	Ref	2.89E-05	0	4.97E-06	-1.98E-07	-1.98E-07	3.37E-05	3.37E-05
	SA1	1.50E-05	0	1.91E-06	-1.58E-06	-4.15E-06	1.53E-05	1.27E-05
	SA2	1.08E-05	0	1.92E-06	-7.25E-07	-3.85E-06	1.20E-05	8.91E-06
CFS	Ref	1.79E-03	0	4.66E-03	-4.07E-05	-6.86E-05	6.41E-03	6.38E-03
	Light	7.70E-04	0	3.69E-03	-1.70E-05	-5.63E-05	4.44E-03	4.40E-03

**Table A.6** Primary Energy Demand (PED) results: comparison with the reference solution

PED (MJ)		Production	Assembly	Use	EoL		LCA	
					Current	Future	Current	Future
FM	Ref	1.38E+03	0	5.08E+03	-6.47E+02	-9.00E+02	5.81E+03	5.56E+03
	Light	4.82E+03	9.54E+00	3.28E+03	-5.57E+02	-1.60E+03	7.56E+03	6.52E+03
FH	Ref	3.02E+02	8.03E-01	1.58E+03	-9.99E+01	-9.99E+01	1.78E+03	1.78E+03
	Light	1.95E+03	7.44E+00	8.84E+02	-3.05E+02	-7.44E+02	2.54E+03	2.10E+03
FD	Ref	1.67E+03	9.27E-01	1.26E+03	-6.00E+02	-1.01E+03	2.33E+03	1.92E+03
	Light	3.00E+03	4.96E+00	1.07E+03	-1.09E+02	-9.67E+02	3.97E+03	<
CDB	Ref	3.75E+02	0.00E+00	1.37E+03	-8.65E+01	-8.65E+01	1.66E+03	1.66E+03
	Light	7.56E+02	0	7.79E+02	-2.83E+02	-6.53E+02	1.25E+03	8.82E+02
SA	Ref	9.16E+01	0	6.41E+02	-3.46E+01	-3.46E+01	6.98E+02	6.98E+02
	SA1	4.89E+02	0	2.46E+02	-8.31E+01	-2.08E+02	6.52E+02	5.27E+02
	SA2	4.57E+02	0	2.48E+02	-5.76E+01	-2.16E+02	6.48E+02	4.89E+02
CFS	Ref	1.12E+04	0	6.39E+03	-1.83E+03	-3.04E+03	1.58E+04	1.46E+04
	Light	8.30E+03	0	5.06E+03	-1.03E+03	-2.98E+03	1.23E+04	1.04E+04

## Appendix B: Tables BP and Performance indicator

Table B.1. BP and Performance indicator according to EoL scenarios

Component	Material pairs	Delta mass	Current EoL			BP	Future EoL			BP
			$\Delta_{I/M}^P$ (ADPeL)	$\Delta_{I/M}^P$ (GWP)	$\Delta_{I/M}^P$ (PED)		$\Delta_{I/M}^P$ (ADPeL)	$\Delta_{I/M}^P$ (GWP)	$\Delta_{I/M}^P$ (PED)	
FM	Metal-to-Composite (<50%ww)	-37%	-4.91E-06	-3.69E+00	-1.27E+02	247616	-3.29E-06	6.61E-01	-6.95E+01	166894
FH	Metal-to-Composite (<50%ww)	-44%	-1.01E-05	-7.87E-00	-1.50E+02	347338	-8.28E-06	-2.68E+00	-6.30E+01	216489
FD	Metal-to-Composite (>50%ww)	-16%	-1.89E-05	-5.24E+01	-1.14E+03	1445256	-1.41E-05	-2.65E+01	-8.26E+02	793508
CDB	Metal-to-Composite (<50%ww)	-43%	-1.47E-05	3.40E+00	9.53E+01	65982	-1.29E-05	8.56E+00	1.81E+02	0
SA 1	Metal-to-Composite (<50%ww)	-55%	8.47E-06	-1.24E-01	3.41E+01	358707	9.64E-06	3.34E+00	9.09E+01	293286
SA 2	Metal-to-Composite (>50%ww)	-55%	9.85E-06	-3.75E-01	2.80E+01	341032	1.13E-05	4.35E+00	1.00E+02	251728
CFS	Metal-to-Composite (<50%ww)	-21%	2.68E-04	3.39E+01	4.73E+02	0	2.68E-04	4.22E+01	5.68E+02	0

## References

1. COM(2016) 501 final: A European Strategy for Low-Emission Mobility
2. P. Egede, F. Nehuis, C. Herrmann, T. Viotor, Integration of eLCAR Guidelines into Vehicle Design, in: Bajpai R., Chandrasekhar U., Arankalle A. (Eds.), Innovative Design, Analysis and Development Practices in Aerospace and Automotive Engineering. Lecture Notes in Mechanical Engineering. Springer, 2014, pp. 235-241
3. D. Jasinski, J. Meredith, K. Kirwan, A comprehensive review of full cost accounting methods and their applicability to the automotive industry, J Clean Prod 108, Part A, (2015) 1123–1139
4. Volkswagen AG, The Golf. Environmental Commendation – Background Report, (2012)
5. Mercedes-Benz, Environmental Certificate Mercedes-Benz S-Class, (2013)
6. M. Finkbeiner, R. Hoffmann, Application of Life Cycle Assessment for the Environmental Certificate of the Mercedes-Benz S-Class (7 pp), Int J Life Cycle Assess. 11, (2006) 240–246, doi: 10.1065/lca2006.05.248
7. C. Koffler, Life cycle assessment of automotive lightweighting through polymers under US boundary conditions. Int J Life Cycle Assess 19, (2013) 538–545. doi: 10.1007/s11367-013-0652-7
8. M. Delogu, F. Del Pero, F. Romoli, M. Pierini, Life Cycle Assessment of a plastic Air Intake Manifold, Int J Life Cycle Assess 20, (2015) 1429–1443
9. A.T. Mayyas, A. Qattawi, A. R Mayyas, M.A. Omar MA, Life cycle assessment-based selection for a sustainable lightweight body-in-white design, Energy 39, (2012b) 412–425, doi: 10.1016/j.energy.2011.12.033
10. S. Das, Life cycle assessment of carbon fiber-reinforced polymer composites, Int J Life Cycle Assess 16, (2011) 268–282. doi: 10.1007/s11367-011-0264-z
11. R. Dhingra, S. Das, Life cycle energy and environmental evaluation of downsized vs. lightweight material automotive engines, J Clean Prod 85, (2014) 347–358, doi: 10.1016/j.jclepro.2014.08.107
12. J.R. Duflou, J. De Moor, I. Verpoest, W. Dewulf, Environmental impact analysis of composite use in car manufacturing. CIRP Ann - Manuf Technol 58, (2009) 9–12, doi: 10.1016/j.cirp.2009.03.077
13. H.S. Park, X.P. Dang, A. Roderburg, B. Nau, Development of plastic front side panels for green cars, CIRP J Manuf Sci Technol 6, (2013) 44–52. doi: 10.1016/j.cirpj.2012.08.002
14. C. Alves, P.M.C. Ferrão, A.J. Silva, et al., Ecodesign of automotive components making use of natural jute fiber composites, J Clean Prod. 18, (2010) 313–327, doi: 10.1016/j.jclepro.2009.10.022

15. S.M. Luz, A. Caldeira-Pires, P.C.M. Ferrão, Environmental benefits of substituting talc by sugarcane bagasse fibers as reinforcement in polypropylene composites: Ecodesign and LCA as strategy for automotive components, *Resour. Conserv. Recycl.* 54, (2010) 1135–1144, doi: 10.1016/j.resconrec.2010.03.009
16. M. Delogu, L. Zanchi, S. Maltese et al., Environmental and economic life cycle assessment of a lightweight solution for an automotive component: A comparison between talc-filled and hollow glass microspheres-reinforced polymer composites, *J Clean Prod* 139, (2016) 548–560, doi: 10.1016/j.jclepro.2016.08.079
17. S. Vinodh, K. Jayakrishna, Environmental impact minimisation in an automotive component using alternative materials and manufacturing processes, *Mater Des* 32, (2011) 5082–5090, doi: 10.1016/j.matdes.2011.06.025
18. M. Raugei, D. Morrey, A. Hutchinson, P. Winfield, A coherent life cycle assessment of a range of lightweighting strategies for compact vehicle, *J Clean Prod.*, (2015) doi: 10.1016/j.jclepro.2015.05.100
19. Renault, FLUENCE and FLUENCE Z.E. LIFE CYCLE ASSESSMENT, (2011)
20. T.R. Hawkins, B. Singh, G. Majeau-Bettez, A. H. Strømman, Comparative Environmental Life Cycle Assessment of Conventional and Electric Vehicles: LCA of Conventional and Electric Vehicles, *J Ind. Ecol.* 17, (2013) 53–64. doi: 10.1111/j.1530-9290.2012.00532.x
21. Girardi P., Gargiulo A., Brambilla P. C., A comparative LCA of an electric vehicle and an internal combustion engine vehicle using the appropriate power mix: the Italian case study, *Int J Life Cycle Assess* (2015) 20:1127–1142, doi 10.1007/s11367-015-0903-x
22. Del Pero, F., Delogu, M., Pierini, M. The effect of lightweighting in automotive LCA perspective: Estimation of mass-induced fuel consumption reduction for gasoline turbocharged vehicles (2017) *Journal of Cleaner Production*, 154, pp. 566-577. DOI: 10.1016/j.jclepro.2017.04.013”
23. T. Bein, D. Mayer, L. Hagebeucker, A. Bachinger, D. Bassan, B. Pluymers, M. Delogu, Enhanced lightweight design – first results of the FP7 project ENLIGHT, *Transportation Research Procedia* 14, (2016) 1031–1040
24. Egede P., *Environmental Assessment of Lightweight Electric Vehicles*, Springer International Publishing Switzerland 2017, doi 10.1007/978-3-319-40277-2
25. H.C. Kim, T. J. Wallington, Life Cycle Assessment of Vehicle Lightweighting: A Physics-Based Model of Mass-Induced Fuel Consumption, *Environ Sci. Technol.* 47, (2013) 14358–14366, doi: 10.1021/es402954w
26. F. Nehuis, S. Kleemann, P. Egede, T. Vietor, C. Herrmann, Future Trends in the Development of Vehicle Bodies Regarding Lightweight and Cost. In: Bajpai R., Chandrasekhar U., Arankalle A. (Eds.) *Innovative Design, Analysis and Development Practices in Aerospace and Automotive Engineering*. Lecture Notes in Mechanical Engineering. Springer, (2014) 13-21
27. J.C. Kelly, J.L. Sullivan, A. Burnham, A. Elgowainy, Impacts of Vehicle Weight Reduction via Material Substitution on Life-Cycle Greenhouse Gas Emissions. *Environ Sci. Technol.* 49, (2015) 12535–12542, doi: 10.1021/acs.est.5b03192
28. H.V. De Medina, Eco-design for materials selection in automobile industry, in: *CIRP international conference on life cycle engineering*, 13th, Leuven, Belgium, 2006, pp 299–304
29. H. Andriankaja, F. Vallet, J. Le Duigou, B. Eynard, A method to ecodesign structural parts in the transport sector based on product life cycle management, *J Clean Prod.* 94, (2015) 165–176, doi: 10.1016/j.jclepro.2015.02.026
30. S. Poulidikou, C. Schneider, A. Björklund, S. Kazemahvazi, P. Wennhage, D. Zenkert, A material selection approach to evaluate material substitution for minimizing the life cycle environmental impact of vehicles, *Materials & Design* 83, (2015) 704–712
31. A. Del Duce, P. Egede, G. Öhlschläger, T. Dettmer, H.J. Althaus, T. Büttler, E. Szczechowicz, eLCAr Guidelines for the LCA of electric vehicles. Deliverable: D2.1 Guidebook for LCA studies in the context of e-mobility, (2013), Available at [http://www.elcar-project.eu/uploads/media/eLCAr\\_guidelines.pdf](http://www.elcar-project.eu/uploads/media/eLCAr_guidelines.pdf). Accessed 5 Dec 2016
32. H. Andriankaja, G. Bertoluci, P.D. Millet, An approach to define a robust set of environmental tools for car parts manufacturer, *Proceedings of the Ecologic Vehicles. Renewable Energies*, (2009) 26-29 March. Monaco
33. EC-JRC European Commission - Joint Research Centre - Institute for Environment and Sustainability: *International Reference Life Cycle Data System (ILCD) Handbook-Recommendations for Life Cycle Impact Assessment in the European context*. First edition November 2011. EUR 24571 EN. Luxemburg. Publications Office of the European Union; 2011
34. R.A. Witik, R. Teuscher, V. Michaud, C. Ludwing, J.E. Manson, Carbon fibre reinforced composite waste: An environmental assessment of recycling, energy recovery and landfilling, *Composites: Part A* 49, (2013) 89–99
35. T. Suzuki, J. Takahashi, Prediction of energy intensity of carbon fiber reinforced plastics for mass-produced passenger cars, (2005)
36. FEICA, *Moving more with less CO2 – Bonding in the Automotive industry, Creating your Sustainable Future with Adhesives & Sealants* (2011)
37. ALIVE – SEAM, *Advanced High Volume Affordable Lightweighting for Future Electric Vehicles*, (2012) Available at:

38. Muttana SB, Sardar A, Lightweighting of battery electric cars: an impact analysis using Indian driving cycle. In: 8th SAEINDIA international mobility conference & exposition and commercial vehicle engineering congress, 2013
39. Reuter B, Kulcsár J, Bradshaw AM, Hamacher T, Lienkamp M., Consequences for the environmental impact during the life cycle of an electric vehicle due to different technical and methodological approaches to the treatment of the car body. In: Conference on future automotive technology, 2013
40. Schuh G, Korthals K, Backs M., Environmental impact of body lightweight design in the operating phase of electric vehicles. In: Nee AYC, Song B, Ong S (eds) Re-engineering manufacturing for sustainability: Proceedings of the 20th CIRP international conference on life cycle engineering, Singapore, 17–19 April 2013. Springer, New York
41. Schuh G, Korthals K, Arnoscht J., Contribution of body lightweight design to the environmental impact of electric vehicles. *Adv Mater Res* 907:329–347, 2014, doi:10.4028/www.scientific.net/AMR.907.329
42. Berzi, L., Delogu, M., Giorgetti, A., Pierini, M. On-field investigation and process modelling of End-of-Life Vehicles treatment in the context of Italian craft-type Authorized Treatment Facilities (2013) *Waste Management*, 33 (4), pp. 892-906. DOI: 10.1016/j.wasman.2012.12.004
43. L. Van Oers, J. Guinée, The Abiotic Depletion Potential: Background, Updates, and Future (Review), *Resources* (2016), doi:10.3390/resources5010016
44. E. Van der Voet, Criticality and abiotic resource depletion in life cycle assessment, In *Security of Supply and Scarcity of Raw Materials. Towards a Methodological Framework for Sustainability Assessment*; Mancini, L., De Camillis, C., Pennington, D., Eds.; European Commission: Luxemburg, (2013) pp. 21–23.
45. S. Sala, L. Benini, V. Castellani et al., Environmental Footprint - Update of Life Cycle Impact Assessment methods; DRAFT for TAB (status: May 2, 2016), *Resources, water, land* (2016)