



UNIVERSITÀ
DEGLI STUDI
FIRENZE

FLORE

Repository istituzionale dell'Università degli Studi di Firenze

Energy storage systems to exploit regenerative braking in DC railway systems: Different approaches to improve efficiency of modern high-

Questa è la versione Preprint (Submitted version) della seguente pubblicazione:

Original Citation:

Energy storage systems to exploit regenerative braking in DC railway systems: Different approaches to improve efficiency of modern high-speed trains / Ceraolo, M.; Lutzenberger, G.*; Meli, E.; Pugi, L.; Rindi, A.; Pancari, G.. - In: JOURNAL OF ENERGY STORAGE. - ISSN 2352-152X. - ELETTRONICO. - 16:(2018), pp. 269-279. [10.1016/j.est.2018.01.017]

Availability:

The webpage <https://hdl.handle.net/2158/1119825> of the repository was last updated on 2021-03-30T14:35:29Z

Published version:

DOI: 10.1016/j.est.2018.01.017

Terms of use:

Open Access

La pubblicazione è resa disponibile sotto le norme e i termini della licenza di deposito, secondo quanto stabilito dalla Policy per l'accesso aperto dell'Università degli Studi di Firenze (<https://www.sba.unifi.it/upload/policy-oa-2016-1.pdf>)

Publisher copyright claim:

Conformità alle politiche dell'editore / Compliance to publisher's policies

Questa versione della pubblicazione è conforme a quanto richiesto dalle politiche dell'editore in materia di copyright.

This version of the publication conforms to the publisher's copyright policies.

La data sopra indicata si riferisce all'ultimo aggiornamento della scheda del Repository FloRe - The above-mentioned date refers to the last update of the record in the Institutional Repository FloRe

(Article begins on next page)

Energy storage systems to exploit regenerative braking in DC railway systems: different approaches to improve efficiency of modern high-speed trains

M. Ceraolo¹, G. Lutzemberger¹, E. Meli², L. Pugi², A. Rindi², G. Pancari³

¹ Department of Energy, Systems, Territory and Constructions Engineering (DESTEC),
University of Pisa, Largo L. Lazzarino - 56122, Pisa (Italy)

² Department of Industrial Engineering (DIEF), University of Florence,
Via di Santa Marta n. 3 - 50139, Firenze (Italy)

³ Italcertifer S.p.A., Largo F.lli Alinari n. 4 - 50123, Firenze (Italy)

ABSTRACT

The growing attention to environmental sustainability of transport systems made necessary to investigate the possibility of energy optimization even in sectors typically characterized by an already high level of sustainability, as in particular the railway system. One of the most promising opportunity is the optimization of the braking energy recovery, which has been already considered in tramway systems, while it is traditionally overlooked for high-speed railway systems. In this research work, the authors have developed two simulation models able to reproduce the behavior of high-speed trains when entering in a railway node, and to analyze the impact of regenerative braking in DC railway systems, including usage of energy storage systems. These models, developed respectively in the Matlab-Simscape environment and in the open source Modelica language, have been experimentally validated considering an Italian high-speed train. After validation, the authors have performed a feasibility analysis considering the use of stationary and on-board storage systems, also by taking into account capital costs of the investment and annual energy saving, to evaluate cost-effectiveness of the different solutions. The analysis has shown the possibility to improve the efficiency of high-speed railway systems, by improving braking energy recovery through the installation of such storage systems.

INTRODUCTION

Nowadays large part of railway vehicles is able to combine the standard pneumatic braking to an electrical braking system, made possible by the electric traction system. In this way, the kinetic energy of the train is converted in electrical energy, which can be handled in different ways. The first and simplest way to manage that energy is to dissipate it on a set of specifically developed resistors placed on-board trains; obviously, this solution comes along with some significant consequences, as example how to properly manage the heat thus generated. A second way is to perform the energy recovery: the electrical energy can be sent back to the contact line where it can be used by other trains during their traction phases, or stored in properly sized energy storage systems located along the feeding line or on-board the trains.

However, electrical braking allows significant advantages also in terms of maintenance costs: in fact, it allows to preserve friction materials of the mechanical brake (pads and discs) from excessive wear rates. This effect is significant in terms of environmental pollution, since mechanical brake particles count for a significant percentage of the air pollution due railway systems [1] [2] [3]. Also maintenance costs should be accurately evaluated, since the wear of braking pads depends on the percentage of train kinetic energy, which is mechanically dissipated. This aspect is detailed in UIC 541 rules [4] [5], where a wear rate index defined as the ratio between the worn volume of tested friction material and the amount of dissipated energy for the testing and homologations of pneumatic braking systems is defined. Additional benefits should be obtained also in terms of protection of brake units from overheating, since electrical braking should be used also when extended braking phases occur. Moreover, the access to braking units for maintenance involves additional time and costs that have to be considered.

Regarding brake blending, i.e. the strategy to optimally apply the action of mechanical and electrical braking systems, several studies are shown in literature. In particular, blending of high-speed trains was the object of previous publications [6] [7], which analyzed the influence of blending strategy on braking pads wear and on the braking system performance, taking into account the variation of the pads friction coefficient due to wear and hence vehicle safety issues. In fact, from the safety point of view, UIC rules [4] [5] clearly specifies that emergency stop maneuver must be entirely ensured by mechanical braking devices, without usage of

electrical braking: for this reason, an optimal management of electrical braking would not only allow energy savings but improve also the system safety.

When electrical braking is performed, two main ways to manage the generated power must be considered:

- Dissipative Braking: generated electrical energy is dissipated over an array of resistors typically controlled by a static converter.
- Regenerative Braking: generated electrical energy is available to be stored on board or redirect to the overhead line.

Regenerative braking is obviously the most interesting technology in terms of efficiency but poses severe limits to the way in which recovered energy is managed considering the following typical solutions which have been widely studied in [8] [9] with a special attention to urban tramway systems [10]:

- Stationary/Infrastructure based Storage Systems. Main advantage is to avoid limitation regarding encumbrances. Main drawback regards additional losses, since energy flows move from the trains to the storage passing through the feeding line. This solution was also considered in literature, considering different storage technologies i.e. lithium batteries [11] [12] or supercapacitors [13] [14]. Energy storage systems are chosen and sized by considering their performance, aging and cost-effectiveness [15] [16], also by considering the possibility to employ already aged batteries [17]. As additional problem to be considered, the presence of an appropriate short circuit protection system, as detailed in some existing safety rules specifically processed for DC systems [18].
- On-board storage systems, in which braking energy is stored on systems installed on-board train [19]. The main advantage is due reduction of losses, since energy transfer along the line is reduced or fully avoided. As drawbacks, additional encumbrances and weights on-board the vehicle, with a consequent reduction of available loading capacity of the train and with an increment of energy requests from the feeding electrical substations (ESSs), during the traction phases.
- Synchronized loads along the line: by optimizing railway timetables and signaling systems it is possible to synchronize the presence on the same line of both trains performing regenerative braking and loads represented by other compositions executing energy-consuming maneuvers (i.e. the traction phase). Thus, the need of energy storage devices is reduced since every time regenerative braking power is generated,

there is one available load that can absorb it. This approach has been widely studied in many works and in light railways [20] [21] [22] it is just one of the possible technical solutions to take advantage of braking energy. On the other hand, in DC high-speed lines the use of braking energy by other synchronized loads within the same line is almost the only solution to exploit braking energy. This solution, although not expensive, shows some drawbacks mainly related to its robustness with respect to traffic perturbations, which are quite common in railway applications. Further troubles arise because railway timetables are also constrained by transport market demand for the employed railway vehicles. As consequence, this further optimization of timetables and signaling could be more efficient only for a few operating scenarios (e.g. intense traffic demand on a line with a quite regular design) than for other ones. In a similar way, additional studies are focused on the improvement of energy efficiency due the driving style, i.e. changing the management of motion phases, to enhance the braking energy recovery [23].

- Reversible feeding substations: power stations used to feed the line could be reversible, to send the regenerative braking energy to the external grid. This solution has been applied to low voltage metro-systems [24] [25]. It is also interesting to observe how reversible feeding sub-stations within AC railway lines are already operating (e.g. within the Firenze-Bologna line). Further interesting studies [26] have been performed concerning the multi-level integration of railway grids within systems devoted to the recharge of other electrical transportation systems, trying to solve with a complex coordinated system the troubles due to reverse power flows, arising from different connected systems. Complexity, costs, difficult scalability are the main drawbacks of this solution, which will be probably extensively adopted in the near future, although it actually not yet diffused.

Most of the previously mentioned studies based on the utilization of energy storage systems are focused on low voltage tramways or light rail DC systems, in which feeding electrical substations (ESSs) are based on diode bridges, thus they are not able to send energy back to the three-phase network. This is mainly due to the parameters that influence regenerative braking. In fact, the peak braking power depends on the vehicle velocity before the braking phase, on the train deceleration and on the vehicle equivalent inertia. On the other hand, the mean recovered energy depends on the vehicle kinetic energy (and then on the squared vehicle velocity) and on the braking frequency (i.e. the number of braking phases scaled with respect to the vehicle traveling time). It is then easy to understand how the analysis and the application of regenerative braking and energy storage

devices have been typically carried out considering light railway systems, like tramways or metro systems, instead of high-speed trains. In fact in those situations, the power peaks that must be handled are smaller (i.e. the vehicles are characterised by a reduced weight and are able to reach a lower vehicle speed). However, the recovered energy may significantly rise up, due the high frequency of braking phases within short distances. As shown by several studies [8] [27] [28], the recovered amount of energy allows a fast payback period for the investment showing the cost-effectiveness of this solution.

Indeed, it can be of interest to evaluate the utilisation of energy storage systems also in case of the high-speed trains, always fed by DC feeding systems. In fact, travelling speed and equivalent inertia are much higher, thus increasing the amount of kinetic energy that can be potentially recovered. On the other hand, reduced number of braking phases and extended railway lines may reduce the cost-effectiveness of the proposed solution, as confirmed by the low achieved interest, although today ever increasing. Therefore, the present research work tried to give some answers regarding these aspects, by analyzing different storage system technologies and configurations, in order to make a cost-benefit analysis for the considered scenario.

First of all the authors have developed two different vehicle-line simulation models: the first model has been developed coupling the Matlab-Simulink™ environment with the innovative object oriented Matlab-Simscape™ language, while the second model has been developed using the open source Modelica environment.

Both the approaches, being object oriented and following the Bond-Graph approach [29] for the modeling of dynamical systems, are characterized by a great flexibility and modularity. They also allow to analyse different scenarios and to perform optimization analysis. These approaches, based on a lumped parameters formulation, handle the physical variables of the system (e.g. current and voltage for electric systems), representing each element of the system with its characteristics equation. In this way, each element contributes to a global system of equations that can be solved using variable step solver and it is possible to avoid the algebraic loop problems typical of a classical Matlab-Simulink™ approach.

The Matlab based model has been experimentally validated considering an Italian high-speed test case: the ETR 1000 high-speed train fed by the 3kV DC feeding system, from Florence to Rome. The validation has

been performed considering a traction phase of the train in a brief part of the line. Then, the model realised in Modelica language has been validated on the same case study, as shown in [30].

After validation, this model has been used to perform a feasibility analysis regarding the usage of stationary and on-board storage systems, based on high power lithium batteries or supercapacitors. The authors have taken into account the needed capital costs for the different solutions on a realistic operating scenario, in which the storage system recovers braking energy when the train comes inside the railway node, and deliver that energy later, to another train when it is leaving the node. Sizing and energy saving for every energy storage system have been accurately evaluated, to analyze the cost-effectiveness of each considered case study.

In the following Sections, the models will be described, and after the exposition of the models experimental validation, the results of the feasibility analysis will be shown.

I. THE SIMULATION MODELS

In order to analyze the feasibility of braking energy recovery in case of the considered high-speed DC railway system, two different models have been developed. They include the feeding electrical substations (ESSs), the network and the trains. The first one has been developed coupling the Matlab-Simulink™ with the Matlab-Simscape™ environment [31], while the second one is all-in-one and written using the Modelica language [32]. The two models have been validated and compared each other, thus the Modelica based one perfectly replies the results of the Matlab based tool. Additionally, it is able to include the different variants of the considered storage systems and properly simulate them.

As already noted, two different modules compose the first model: one is developed in the Matlab-Simulink™ environment and is used to analyze the vehicle longitudinal dynamics, while the second one is developed with Matlab-Simscape™ through standard and customized blocks, to analyse the electrical energy flows on the feeding line. The general architecture of the DC railway system model is depicted in Figure 1, showing the Matlab version appearance [33]. The Modelica one has a similar graphical aspect. The use of the innovative object oriented Modelica and Simscape languages allow to obtain great advantages in terms of modularity and computational efficiency; furthermore, Modelica and Simscape blocks handle physical quantities and allow to solve the complete model as a unique system of equations built through a symbolic approach.

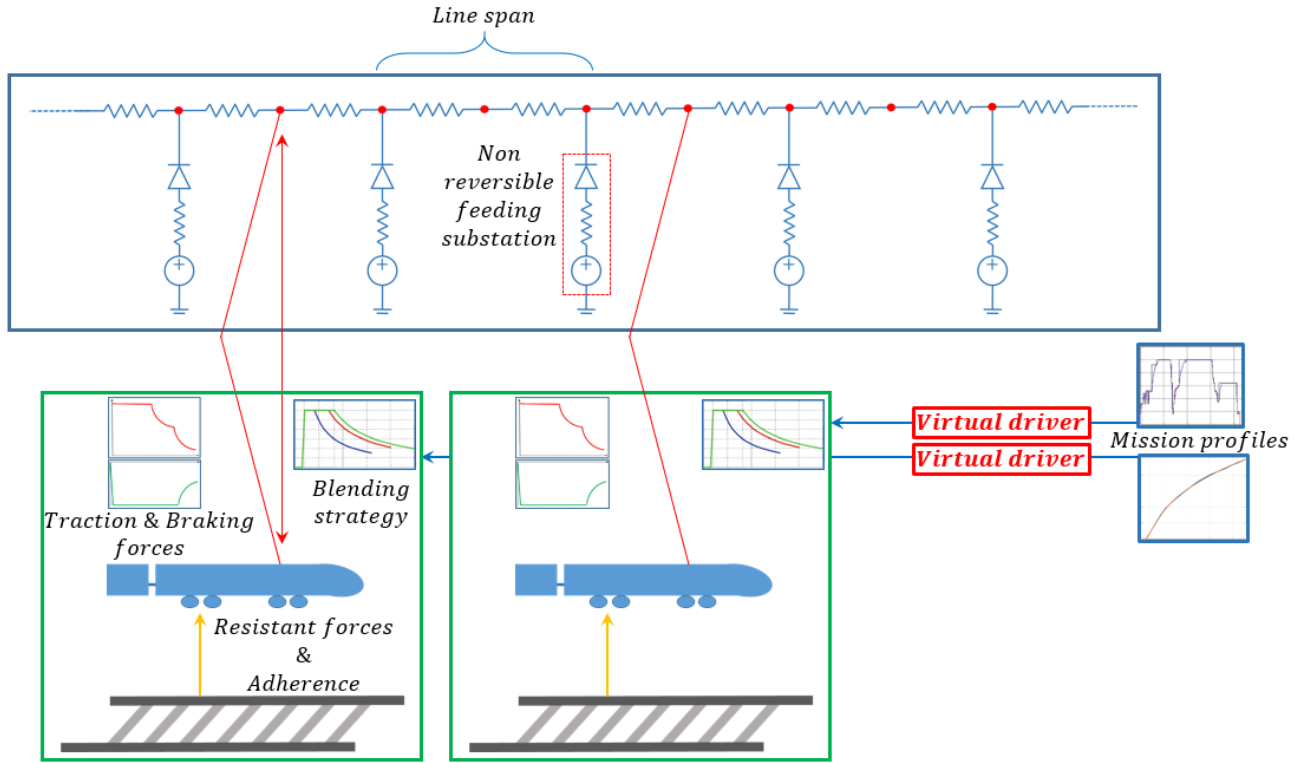

Figure 1. General architecture of the model.

The vehicle model represents the train motion through a lumped parameters approach: the complete train is modelled as a concentrated mass, which is subjected to traction and braking forces and to various resistant forces due to the line topology and to the vehicle motion itself. The equation of motion of the vehicle can be expressed as follow:

$$m\ddot{x} = T - (F_{rr} + F_{rs} + F_{ra} + F_{rc}) \quad (1)$$

Where m is the effective vehicle mass, thus including equivalent inertia of rotating parts, \ddot{x} its acceleration, T the traction and braking efforts, F_{rr} the resistance force due to the rolling resistance, F_{rs} the resistant force due to the track slope, F_{ra} the resistant force due to the aerodynamic drag and F_{rc} the resistance force due curves along the track. This last term was not taken into account in the present analysis.

The braking forces due to the different braking systems of the train (i.e. pneumatic and electric, which can be regenerative or dissipative depending on the receptivity of the line) are calculated taking into account the blending strategy chosen by the user; in this research work the blending strategy acts in order to maximize the percentage of electrical braking energy. The available electric traction force is calculated and compared with

the limits imposed by adherence, and line operating conditions; if the force provided by the electric braking system exceeds those limits, the remaining part is provided by the pneumatic braking system.

The vehicle motion is driven by a virtual driver (based on a nonlinear PID controller) which allows the user to choose a mission profile in terms of desired speed for each position of the train within the line. Furthermore, vehicle model includes a voltage limiter device: this device turns off regenerative braking when the energy sent back to the line exceeds a safety limit in terms of line voltage peak.

The feeding line model includes different elements, which allow, thanks to the great modularity provided by the considered modelling languages, to analyse in the easiest way different feeding line layouts. In particular, the contact line has been modelled as a series of variable impedances whose values depend on the train position within each line span and which are connected to the feeding substations, according to the approach already followed in [8] [34]. Those impedances can be written as follow:

$$R_1 = \rho \cdot x \tag{2}$$

$$R_2 = \rho \cdot (l - x) \tag{3}$$

Where, ρ is the line distributed impedance, x is the vehicle distance from the previous substation and l is the distance between two adjacent substations.

Furthermore, the feeding electrical substations (ESSs) have been modelled as real voltage generators, taking into account their internal losses, and are connected in series with a diode in order to correctly represent the non-reversibility of the feeding substations.

The model, thanks to the characteristics of the symbolic Matlab-Simscape™ and Modelica languages, is then assembled in a unique system of differential and algebraic equations (DAE) and can be solved with variable step solvers for stiff DAE problems.

The simulator realised in Modelica language was specifically derived from another tool developed for tramway systems [34], tested and validated on existing case studies [8]. Its basic structure is the same as already shown in Figure 1 (only the visual icons are different). The contact line configuration is subjected to changes, since the train position varies with time. Electric drives are simulated as a system able to produce the requested

torque, modelling losses in an algebraic way, while then train model simply describes its longitudinal behavior, subjected to rolling and aerodynamic resistance forces.

The electrochemical storage system has been modelled through an equivalent electrical network composed by an electromotive force, an inner resistance and additional resistors-capacitors series. In general, all circuit parameters are function of the state of charge and temperature, and they can be calibrated through some experimental test procedures [35]. However, for our purpose all these dependences are neglected, except linear dependence of the electromotive force E from state of charge (SOC), defined as in equations (4) and (5):

$$SOC = 1 - \frac{Q_e}{C_n} = 1 - \frac{1}{C_n} \int_0^t i(t) dt \quad (4)$$

$$E = E_0 + E_1 SOC \quad (5)$$

Where Q_e is the extracted charge, C_n the nominal battery capacity. The storage efficiency is determined by energy loss due circuit resistances, plus the addition of a parasitic current, which is part of the terminal current which does not contribute to the charge process, to take into account energy inefficiencies due to non-unity charge efficiency [35]. A similar approach has been followed also to model supercapacitors.

II. RESULTS ON THE APPLICATION

A. The considered case study

For the experimental validation of the proposed model and for the feasibility analysis performed in this research work, the authors have considered an Italian high-speed DC railway system.

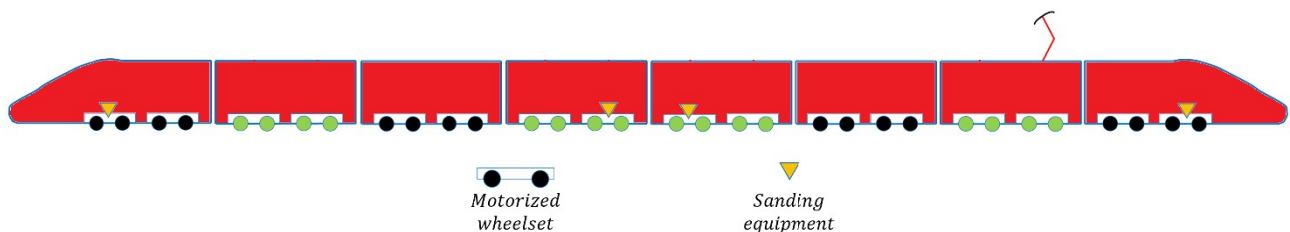

Figure 2. ETR 1000 High-Speed train composition.

The considered high-speed train is the Italian ETR 1000, a train equipped with a distributed traction system and able to operate both under DC and AC electrifications, thus being able to operate within the main European high-speed lines; its pantographs are designed to operate with different voltage values. The train (whose scheme is shown in Figure 2) has a fixed composition, which includes four motorized railcars and other four

wagons; the traction and the braking characteristics of the electric traction system are shown in Figure 3. As observable, the braking characteristic is asymmetric respect to the traction one, with lower limits in terms of force/power, fully interdicted at reduced speed, within 3 m/s. The train is able to perform regenerative braking but is not provided with on-board storage device. Furthermore, the sub-stations of the DC line are not reversible and there are not stationary storage devices; hence, the use of regenerative braking is limited to the presence of other train in the proximity, engaged in the traction phase.

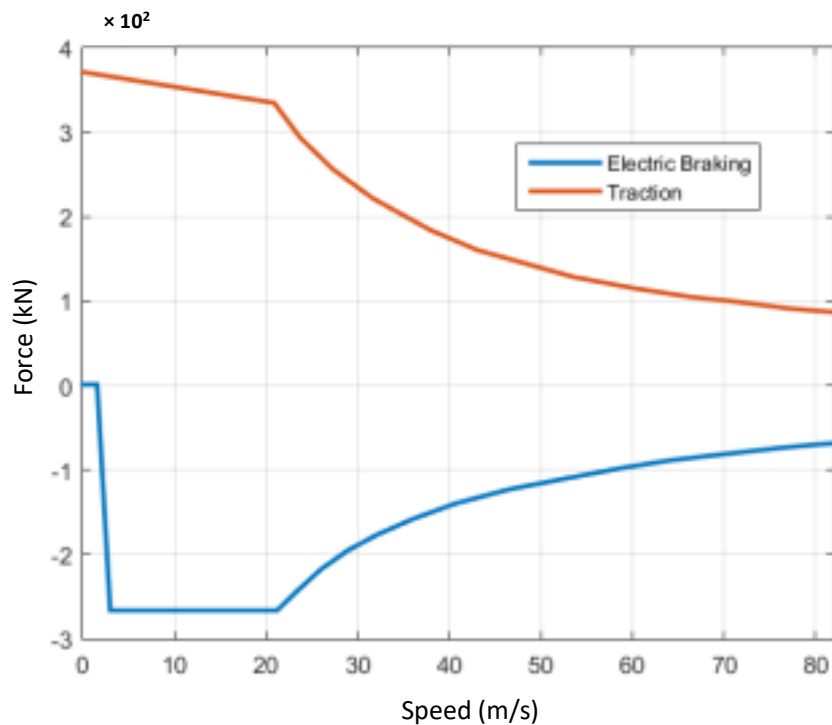

Figure 3. Electric traction and braking characteristics of the ETR 1000 High-Speed train.

The considered line is the high-speed line from Florence to Rome, i.e. the so called “Direttissima” line. This line is fed by non-reversible sub-stations located at a mean distance of about 15 km; the electrification is of 3 kV DC voltage type. The main characteristics of the train and of the DC feeding line already shown in [30] are recalled for clarity in Table 1.

Table 1: Main characteristics of the ETR 1000 high-speed train and of the “Direttissima” high-speed DC line.

Total seats	470
Car body construction	Aluminum Alloy
Train mass	500 t
Train length	202 m
Axle load	17 t
Gauge	Standard 1435 mm
Rotating inertia respect to train mass	4 %
Wheel diameter	920 mm
UIC classification	Bo'Bo'+2'2'+Bo'Bo'+2'2'+2'2'+Bo'Bo'+2'2'+Bo'Bo'
Motorized weight fraction	0.5 [-]
Traction system	Water-cooled IGBT Converters and Asynchronous AC Traction Motors
Supported electrification standards	25 kV 50 Hz, 15 kV 16.7 Hz, 3 kV DC, 1.5 kV DC
Nominal power	9.8 MW
Max tractive effort (standstill)	370 kN
Max speed (design)	400 km/h
Max speed (commercial)	360 km/h
Acceleration / Dec. performance	0.7 ms ⁻² (acceleration phase) / 1.2 ms ⁻² (deceleration phase)
Braking system	Electro-Pneumatic, Electric Braking (both regenerative or dissipative), Magnetic Track Brake
Brake pad consumption	0.1-0.2 cm ³ /MJ (depending on installed brake pad and demanded brake power)
Line impedance (ρ)	0.05 Ω /km
ESS No load voltage	3700 V
ESS EQ. impedance	0.09 Ω
Full length	253.6 km
Mean distance between ESSs	14.7 km
Min distance between ESSs	12 km
Max distance between ESSs	16.8 km

B. Simulation results on the traction phase

The first ETR1000 simulation model has been realised in Matlab-Simscape. As detailed in the previous Sections and in [30], the model has been validated through experimental data concerning a traction phase, i.e. an acceleration phase starting from 0 up to 250 km/h, performed on the DC high-speed line, from Rome to Florence. Comparing simulated and measured speed profile, it was possible to preliminary verify the main parameters concerning traction performance, inertia and motion resistance. Then, also parameters concerning electric drive efficiency, feeding line and feeding electrical substations (ESSs) have been refined, to make equivalent simulation results with the experimental ones.

The traction phase considered for validation includes a significant portion where the traction system operates at constant power condition: this aspect allows to perform a more accurate calibration of the numerical values of the global efficiency of the traction system as function of the tractive force and the train velocity, as in Figure 4.

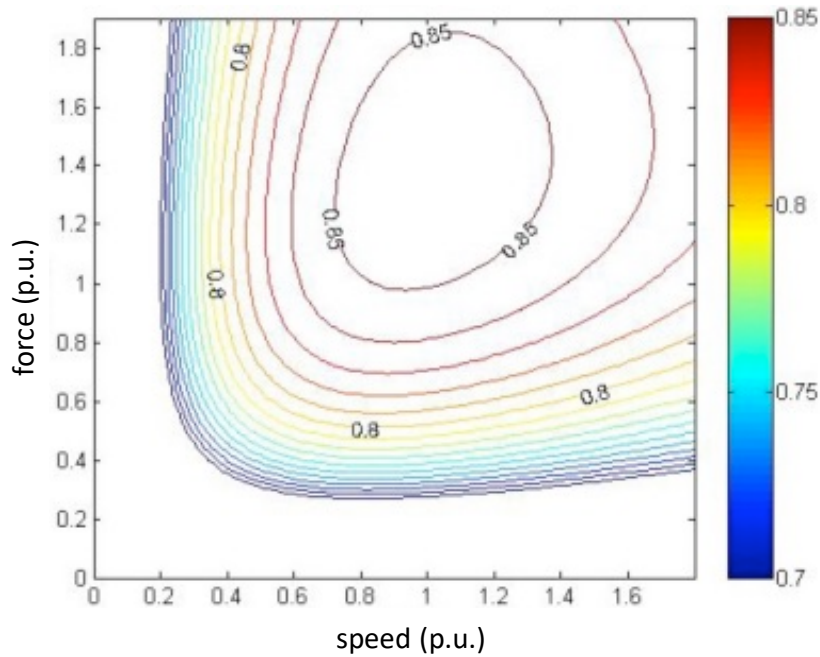

Figure 4. Estimated global efficiency of the traction system as a function of the tractive force and the vehicle speed

Furthermore, thanks to the presence of a stationary phase before the manoeuvre, it was possible to evaluate the power consumption due to on-board auxiliary systems (i.e. 230 kW) and to refine the knowledge of the feeding line and of the electrical substation parameters. The no-load substation voltage has been evaluated during the stationary phase while the substation equivalent impedance has been evaluated during the traction phase. Finally, using current and voltage measurements, it has been also possible to tune the line distributed impedances.

After validating the Matlab-SimscapTM model, simulations have been performed also using the Modelica model. Naturally, physical and control parameters have been tuned in order to obtain comparable results. The results from the two tools can be used to analyze the energy flows between wheels and the feeding electrical substations (ESSs). As an example, it is possible to achieve from simulation results the sharing of the energy delivered by the electrical substation, during the considered traction phase. More in detail, the 57% of the full amount of energy is converted in kinetic energy. Around 10% of energy is dissipated on the contact line, while electric drive losses and auxiliary loads spend, respectively, 18% and 4% respectively. Finally, 11% is adsorbed by motion resistance. It is particularly noticeable that large part of the supplied energy goes into trains' kinetic energy, which is not yet lost and can be recovered during future braking actions.

C. Simulation results on the braking phase

After considering the traction phase, we consider a braking phase, to evaluate the amount of the energy, which can be recovered in correspondence of the entrance in the rail junction, in which several DC railway lines flow as shown in the scheme of Figure 5, regarding the railway junction of Florence. The train is positioned on the DC high-speed line “Direttissima” (the red line from Rome), and the braking phase, accordingly to the actual operating conditions (i.e. starting from 250 km/h), never overcomes 0.8 m/s^2 , for a duration of about 220 s and a covered distance of about 10 km.

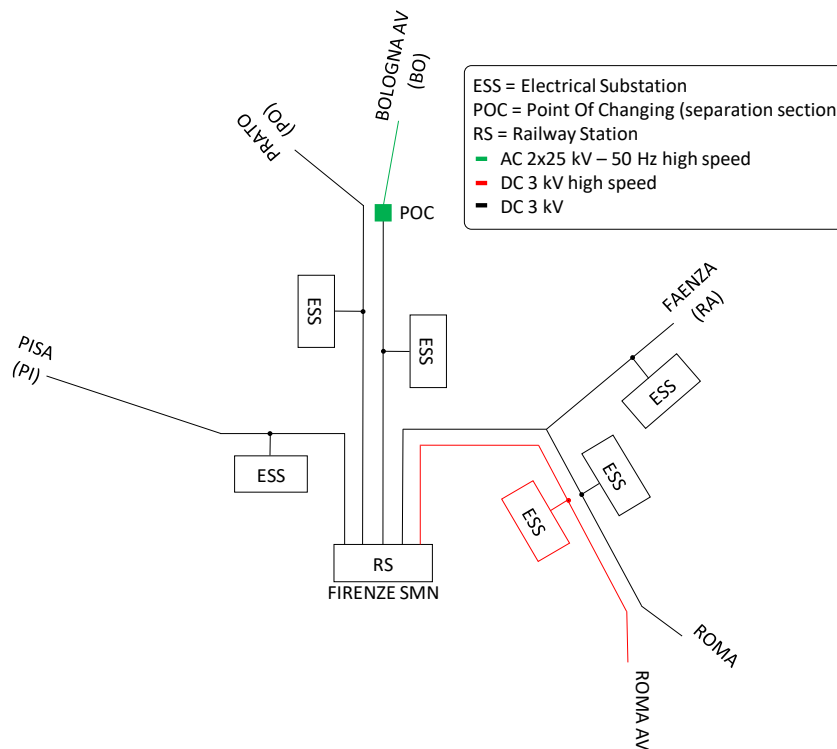

Figure 5. Main railway lines flowing in the considered railway junction.

To evaluate braking only the Modelica based tool has been used. Two different braking characteristics have been considered. One, in which exactly the same curves already shown in Figure 3 are, with asymmetric limits for braking and traction. A second one, in which the braking characteristic is modified in such a way that when braking the torque has the same value as when in traction, at equal speed: the characteristic is *made symmetric*. This to give a feeling of the advantages of having a symmetric characteristic, thus allowing better energy recovery. The efficiency map shown in Figure 4 was used, for the two considered cases.

To enhance energy recovery during braking, otherwise constrained by the need to have other trains that at the same time are adsorbing power in the vicinity as in other typical railway applications [8], the utilisation of some energy storage has been foreseen. Several variants of storage systems can be considered:

- 1) Stationary systems, interfaced with the feeding line by means of DC/DC converters:
 - Systems based on supercapacitors.
 - Systems based on high power lithium batteries.

Since the trips under study only has two stops, the position of the stationary storage can be reasonably located in correspondence of the feeding electrical substation nearer to one of the two terminals, i.e. Florence or Rome. Then, the storage has been sized considering only the energy flows of the DC high-speed line (i.e. the red line in the scheme of Figure 5), i.e. neglecting the other connected DC lines. This, because DC low speed lines typically involve an absorption of power of around one order of magnitude lower than high-speed trains; thus, their contribution to braking energy recovery is basically negligible. The influence of nearby AC high-speed lines (i.e. the green line in the scheme of Figure 5) must also be neglected, since their nearby braking energy is sent directly on the three-phase AC supply network, using reversible substations. Then, the entrance in the rail junction comes at lower speed, without the possibility to recover a significant amount of energy. The intermediate connection between the AC 2×25 kV – 50 Hz (the green line from Bologna) and the 3 kV DC feeding system is indicated by the POC (Point Of Changing) separation section, as shown in Figure 5. Finally, it has been considered that only another train outgoing the same junction can later reuse the braking energy recovered by one train incoming.

The presence of the DC/DC converter is justified even if it, obviously, comes with additional space, weight, cost, complexity. This because of the advantages this component can bring:

- Improvement of the braking energy recovery. When the battery is without the interposition of the DC/DC converter, the transfer of braking energy is governed mainly by the difference between the line voltage and the battery electromotive force, thus progressively reducing the energy flow in the electrochemical storage system during charging, since the distance tends to reduce. With the presence of the DC/DC converter, the voltage is maintained on a fixed reference value (i.e. typically about no-load voltage of ESS, thus avoiding the recharging from ESS may occur) for the overall duration of the braking phase.

- Flexibility in the sizing of the storage itself, being the battery voltage not directly constrained to the grid operating voltage window. Then, the battery current can be brought to the physical limits due to battery (and converter) construction. Finally, SOC can be directly controlled. These facts help increase the battery life, since limit over-temperature; indeed, the presence of the DC/DC converter is recommended, and this configuration was used as reference.

A comparison between solutions with or without a DC/DC converter, in case of tramways, was also shown in [8]. Results of the case study in which the battery is directly connected to the ESS, applied to the case of high-speed trains, are presented in [30].

2) Systems on-board trains, interfaced by means of DC/DC converters:

- Systems based on supercapacitors.
- Systems based on high power lithium batteries.

In case of on-board configuration, the storage size considers the braking energy flow of the train itself. The obtained size complies with the available volume, and the weight constraints.

Similar considerations regarding the DC/DC converter can be made for on-board storage systems, installed having as reference the scheme of Figure 6.

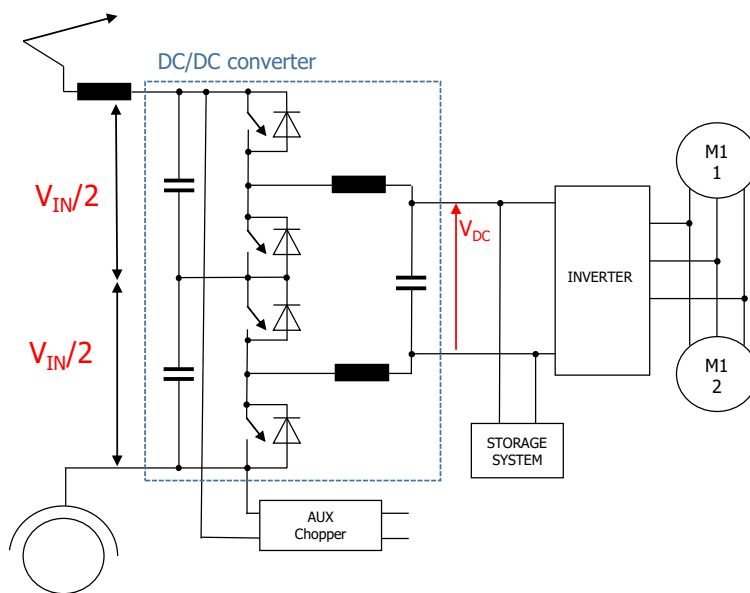

Figure 6. Scheme of the on-board electric drive.

D. Storage system sizing

D.1. Stationary systems based on high power lithium battery

In a first case, a stationary lithium battery pack is connected to the feeding line through the DC/DC converter. Table 2 shows the main battery pack characteristics, based on NMC cells expressively dedicated for high power applications. Two variants have been considered, respectively for symmetric or asymmetric electric drive characteristics, as discussed before. The first rows show battery pack data, while the last ones refer to simulation results, in terms of recovered energy and SOC variation during braking. Naturally, the proposed battery characteristics are compliant with the maximum allowed charging current limit, as declared by the manufacturer.

The battery pack mass and volume are 20% larger than the values due to the cells involved, to take into account the balance of plant (BOP).

The battery has been chosen also by taking into account the cell life. In this regard, considering about 25 trains per day entering/going out in the railway junction and a full duration of 15 years, about 10^5 charging-discharging cycles are expected. Thus, from literature [15] [16] [36] and indication by manufacturers [37], depth of discharge corresponding to such micro-cycles should not overcome 15%.

Table 2: Main characteristics of the battery pack, stationary configuration.

Battery pack (NMC cells based)		
	Symm. electric drive	Asymm. electric drive
Number of cells	1900	1050
Nominal cell voltage (V)	3.7	3.7
Nominal cell capacity (Ah)	400	300
Battery pack nominal energy (kWh)	1406	1166
Battery pack mass (kg)	10032	8856
Battery pack volume (L)	5046	4183
Recovered energy (kWh)	222	186
SOC variation (%)	15	15

Some significant results from simulation during the considered braking phase, including speed profile, pantograph voltage and power, and battery SOC versus time are shown in Figure 7. As noticeable, in the first part of the braking phase, the voltage reaches its maximum admitted value since the long distance between the energy storage system and the train (i.e. about 10 km), and a significant part of the recoverable energy is dissipated in on-board resistors, while the remaining part is stored inside the storage. Then, the action of the DC/DC converter, able to control its output voltage (i.e. fixing its value in correspondence of the electrical substation where it is installed) and the energy storage system SOC variation, determines the last part of the braking energy recovery.

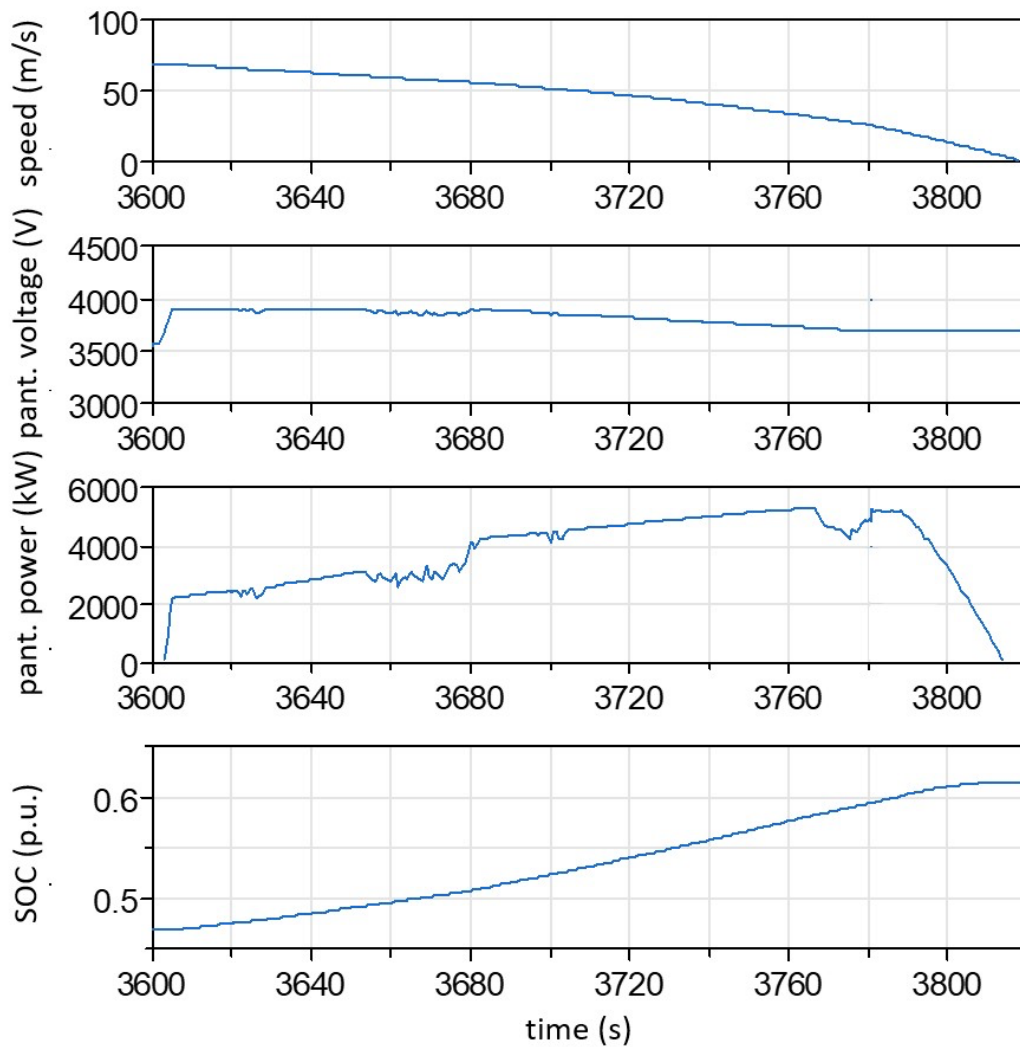

Figure 7. Results under the considered braking phase, stationary storage system based on high power lithium batteries.

As for the previously considered traction phase, it is possible to evaluate the sharing of energy flows during braking. The pie chart shown in Figure 8 (left) shows the energy flows from the wheels to the stationary storage

system, for the considered braking, in case of symmetric limits for the electric drive (i.e. having same force/power limits for traction and braking). The full amount of kinetic and potential energy is converted during braking in the following contributions: from the mechanical point of view, there are losses due to motion resistance and to mechanical braking, while the remaining part is managed by the electric drive. About one-half of the initial amount of energy (436 kWh) is stored inside the stationary storage system (222 kWh), while the remaining parts are shared mainly between electric drive losses (100 kWh) and motion resistance (57 kWh). The percentage of the energy stored inside the storage system is significantly higher than in the case of a battery without DC/DC converter [30]. In that case, only 21% was stored inside the storage system, and 31% was dissipated on-board resistors, thus confirming that the DC/DC converter can significantly improve the braking energy recovery.

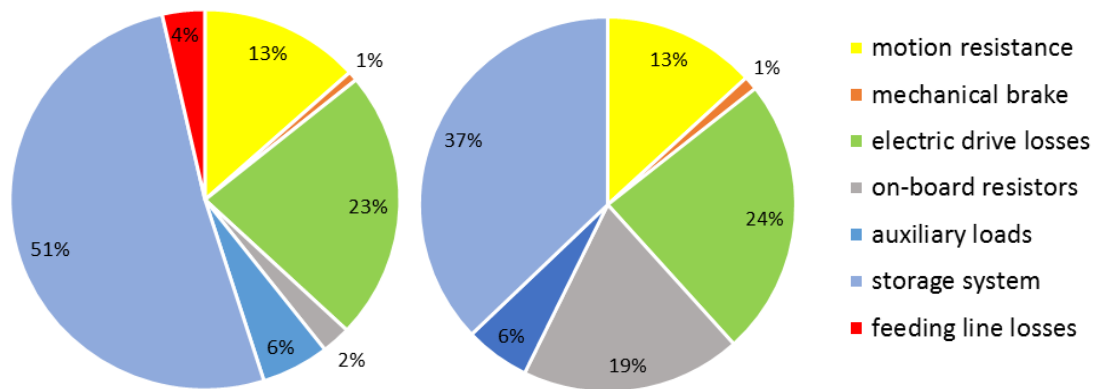

Figure 8. Share of energy flows during braking; stationary storage system (left), on-board storage system (right).

D.2. Stationary systems based on supercapacitors

Since braking durations are longer than 100 s, thus requiring a large amount of energy to be stored, the solution based on supercapacitors appears less competitive than shown in tramways applications, where power peaks are required for a few seconds [8]. The results are shown in Table 3, where the same amount of recovered energy of the previous case, i.e. about 222 kWh and 186 kWh, are considered. Cell voltage and capacitance are from available products. Stack mass and volume takes into account the balance of plant (BOP). Note that while the recovered energy is slight equivalent, stack mass and volume are significantly larger respect to the battery pack detailed in Table 2.

Table 3: Main characteristics of the supercapacitor stack, stationary configuration.

Supercapacitor stack		
	Symm. electric drive	Asymm. electric drive
Number of cells	87000	73500
Nominal cell voltage (V)	2.7	2.7
Nominal cell capacitance (F)	3000	3000
SC stack nominal energy (kWh)	223	189
SC stack mass (kg)	52200	44100
SC stack volume (L)	41760	35280
Recovered energy (kWh)	222	186
SOC variation (%)	99	99

It must however be mentioned, as for the battery solution, that the size was chosen to stay within the recommended current limits (i.e. 2000 A for the considered SC cell). On the other hand, the depth of discharge has not to be limited (i.e. simulated SOC variation is slightly under 100%), being the cycle life of supercapacitors guaranteed for several hundreds of thousands, also in case of full discharge.

D.3. On-board systems based on high power lithium battery

The installation of stationary storage systems has the main drawback that braking energy must flow on the supply line, causing losses to occur. An alternative solution is to install storage systems directly on-board trains. This solution aims to avoid voltage drop on the supply line, when in traction, and voltage rise when braking (possibly causing some on-board dissipation of part of the recovered energy). Each storage has to manage only the load request from the train in which is installed, as for the case study detailed in [8].

On the other hand, this solution requires higher costs due to the need of having one storage system for every train, with further disadvantages in terms of space occupation and mass increment, thus increasing the energy consumptions. However, the storage system could replace in theory on-board resistors, correspondingly reducing space occupation and mass. In this regard, UIC 544-1 (2013) [38] and TSI (2014) [39] rules require safety emergency stop to be completely demanded to mechanical brakes. Therefore, the storage system can fully replace the on-board resistors since also in case of battery failure emergency stop would be guaranteed. Naturally, increment of mass has a negative impact also on electrical energy consumption.

The on-board variant was selected starting from the computation of the volume currently occupied by the brake resistor units. Normally, they are enclosed in shaped boxes equipped with air intakes, including the resistor banks, the cooling fans and the resistor enclosure, as detailed in [40]. From a brief evaluation of the railroad cars encumbrances [41] and from analysis shown in [40], a volume slightly higher than $1.1 \cdot 10^3$ L was estimated. Because of the cooling requirements to dissipate the generated heating, it is possible to consider the volume effectively used by the previously mentioned components is about one-half of the full volume, as also inferable from existing realisations [42]. Then, considering that we have one brake resistor unit for each powered truck, and ETR1000 contains four powered cars, each of which equipped with two railroad trucks [41], we have 8 brake resistor units on-board, corresponding to an available volume of about $4 \cdot 10^3$ L. In terms of weight, if we consider iron and nickel-chromium alloys as material used, it is possible to estimate it in about 3.5 tonnes.

Starting from these values, a battery pack characterised by a further reduced space occupation has been conservatively chosen, and shown in Table 4. As before, two variants have been considered, respectively for symmetric or asymmetric electric drive characteristics. However, space occupation gave the most restrictive constraint for the storage sizing, making useless the use of the electric driver capable of larger energy recovery. Consequently, one only battery pack has been sized, for the two variants under study. The first rows show the battery pack sizing, while the last ones refer to simulation results, in terms of energy recovered and SOC variation under the braking under consideration.

The corresponding weight overcomes of about 2.5 tonnes the previous one. According to EN 14363:2016 standard [43], we must carefully verify that the mass increase was within 6% of the railway carriage, trailer or motor. Prudently considering the full weight equally distributed between the four motorized railcars and the other four wagons, we obtain a mass increment of about 4%, thus avoiding any modification in the homologation procedure.

Table 4: Main characteristics of the battery pack, on-board configuration.

Battery pack (NMC cells based)		
	Symm. electric drive	Asymm. electric drive
Number of cells	1360	
Nominal cell voltage (V)	3.7	
Nominal cell capacity (Ah)	400	
Battery pack nominal energy (kWh)	1006	
Battery pack mass (kg)	5984	
Battery pack volume (L)	3612	
Recovered energy (kWh)	164	
SOC variation (%)	15	

The presented storage system variants make use of NMC cells, dedicated for high power applications. For the reasons already explained, DC/DC converter is used.

When energy flows are considered, the distribution among different contributions changes respect to the stationary storage, as observable in Figure 8 (right), always in case of symmetric limits for the electric drive (i.e. having same force/power limits for traction and braking). In particular, motion resistance varies due to the weight increase caused by the presence of the storage on board. Then, losses on the feeding line between the train and the storage are naturally canceled, while energy dissipated on on-board resistors increases (from 2% up to 19%), because the available braking energy cannot be stored inside the storage, having a reduced sizing due the need to stay within the available volumes on-board. Finally, only 37% of the initial amount of energy is stored inside the on-board storage system.

D.4. On-board systems based on supercapacitors

The final case can be easily interpreted having as reference the results already detailed in the previous Section. The considered version has been newly chosen starting from constraints in terms of volume and mass. The supercapacitor reference cell is the same already used for the stationary systems based on supercapacitors. The supercapacitor that has been chosen for the application has the characteristics shown in Table 5.

Table 5: Main characteristics of the supercapacitor stack, on-board configuration.

Supercapacitor stack		
	Symm. electric drive	Asymm. electric drive
Number of cells	7535	
Nominal cell voltage (V)	2.7	
Nominal cell capacitance (F)	3000	
SC stack nominal energy (kWh)	19.4	
SC stack mass (kg)	4521	
SC stack volume (L)	3617	
Recovered energy (kWh)	19.2	
SOC variation (%)	99	

With mass and volume near to the previous one selected battery pack, the stored usable energy is much lower. If, instead, the comparison with the battery is made at equal energy, the supercapacitor would have unacceptable volume and weight. Remember that we are considering a train refitting which does not require re-homologation according to EN 14363:2016 [43], which imposes any weight variation not to overcome 6% of the original wagon or motorized railcar weight.

E. Cost-benefit analysis

The considered scenario refers to railway companies wishful to upgrade their plants through the installation of stationary or on-board storage systems. The presented cost analysis takes into account the following parameters:

- The initial cash outlay due to the purchase of the storage systems and the power converter, balance of plant included, according to the previously explained configurations. Regarding high power batteries based on NMC cells, a cost of 600 €/kWh has been considered, including cells, BMS, battery packaging. About supercapacitors, a cost of 0.02 €/F has been chosen, including also assembly costs for the stack. The same price has been considered for stationary and mobile application. About DC/DC converter, a fixed cost of 60 k€ was considered from manufacturer indication [44]. The higher cost respect to what has been considered for tramway applications [8] is due the highest power (2 MW) and highest voltage (3.9 kV).
- The annual energy saving from ESSs. Energy saving can be easily determined by evaluating the energy recovered inside the storage system, during regenerative braking of the train entering in the railway node. In case of stationary storage system, this energy can be transferred to another train that is going out, thus reducing the delivered energy from the ESS nearer to the railway node under consideration (i.e. Florence

in the considered case study). Naturally, charging-discharging storage efficiency must also be taken into account, posed equal to 0.9. Annual saving has been evaluated considering a number of 25 trains/day, for 350 days/year. In case of on-board storage system, the recovered energy feeds the same train during its acceleration, going out from the railway node, considering the same charging-discharging efficiency. As in the previous case, it has been considered a number of 25 braking phases/day, for 350 days/year. Finally, current user price of electrical energy in Italy has been posed equal to 100 €/MWh.

The main objective of the analysis was related to the identification of the payback time (PBT) and net present value (NPV) of the investment, by considering a whole life of the plant of 15 years. In terms of maintenance costs, supercapacitors and batteries have been considered able to cover the whole life of the plant. Results have been detailed in Table 6, where the storage systems already shown in Section II.D, in their larger or reduced variants, have been considered to evaluate how the storage sizing can influence the cost-effectiveness of the considered investment.

Table 6: Cost-benefit analysis.

location	cell typology	nominal energy (kWh)	storage system cost (k€)	energy saving (k€/y)	payback time (y)	VAN (k€)
stationary	Li-bat	1406	904	175	5.9	998
stationary	Li-bat	1166	760	147	5.9	837
on-board	Li-bat	1006	664	126	6	714
stationary	SC	223	5280	175	-	-3209
stationary	SC	189	4470	147	-	-2730
on-board	SC	19	512	15	-	-329

It can be noted that the installation of one stationary storage system based on lithium batteries has a payback time around 6 years, and a net present value after 15 years of 998 k€ in the proposed configuration (i.e. 1406 kWh). The same payback time, but a reduced VAN can be obtained when a smaller storage sizing (i.e. 1166 kWh) is considered.

In case of the on-board variants, payback time remain substantially confined to 6 years, while net present value tends to decrease, since the reduced available volume to install the storage on-board. However, many uncertainties may occur, since the need to make modifications on trains, respect to the easiest installation of stationary systems in correspondence of the ESSs.

The competitiveness of supercapacitors is strongly limited by the high initial cash outlay, in relation to the reduced energy saving. As visible always from Table 6, at equal annual energy saving, storage system cost rises up about 5.3 M€ respect to 0.9 M€ of the larger stationary storage based on lithium battery. Indeed, payback time (PBT) is never reached, and net present value (NPV) remains negative for the whole life of the plant.

Finally, also in the case of on-board SC variant, the payback time (PBT) is never reached, and net present value (NPV) remains negative for the whole life of the plant.

CONCLUSIONS AND FUTURE DEVELOPMENTS

Nowadays, improvement of energetic efficiency has become pushing even in the railway sector, typically the most efficient transport sector. In this research, the authors have investigated the feasibility of one of the most promising strategy, i.e. regenerative braking and energy storage, within a DC high-speed railway system. Two different DC railway models have been developed using different modelling environments, and considering an Italian high-speed case study to perform a detailed analysis concerning the use of regenerative braking. In the present study, stationary and on-board batteries and supercapacitors have been considered. The analysis has shown that braking energy recovery is able to provide significant energy and costs saving even in DC high-speed railway systems, opening new research opportunities for the future. In fact, when stationary or on-board storage systems based on lithium batteries are considered, payback time is slightly after one third of the considered life for the plant. It has been verified that supercapacitors, mainly because of the high energy-to-power ratio of this application, cannot compete in terms of cost-effectiveness.

This research could be extended by considering more complicated traffic conditions, with more than one train on the same line, or with other trains on lines forming part of the same railway node, taking also into account the possibility to optimize timetable, signalling and train driving.

ACKNOWLEDGMENTS

The authors would like to thank Dr. Eng. Stefano Bianchi from Italcertifer S.p.A., for its contribution in providing experimental data regarding the traction phase described in Section II.B.

REFERENCES

- [1] P. Presciani, M. Rinchi, L. Pugi, “Banchi per la certificazione dei componenti frenanti (2003)”, *Ingegneria Ferroviaria*, 58 (3), pp. 285-294.
- [2] M. J. Nieuwenhuijsen, J.E. Gomez-Perales, R.N. Colvile, “Levels of particulate air pollution, its elemental composition, determinants and health effects in metro systems”, *Atmospheric Environment*, vol. 41, n. 37, pp. 7995-8006, 2007.
- [3] H. G. Namgung, J. B. Kim, S. H. Woo, S. Park, M. Kim, M. S. Kim, S. B. Kwon, “Generation of Nanoparticles from Friction between Railway Brake Disks and Pads”, *Environmental science & technology*, vol. 50, n. 7, pp. 3453-3461, 2016.
- [4] UIC 541-3: Brakes - Disc Brakes and their application -general conditions for the approval of brake pads.
- [5] UIC 541-4: Brakes - Brakes with Composite Brake Blocks - General Conditions For Certification Of Composite Brake Blocks.
- [6] L. Pugi, M. Malvezzi, S. Papini and S. Tesi, “Simulation of Braking Performances: the application on AnsaldoBreda EMU V250”, *Proceedings of the Institution of Mechanical Engineers, Part F: Journal of rail and rapid transit*, 2016.
- [7] L. Pugi, M. Malvezzi, S. Papini and G. Vettori, “Design and preliminary validation of a tool for the simulation of train braking performance”, *Journal of Modern Transportation*, vol. 21, n. 4, pp. 247-257, 2013.
- [8] M. Ceraolo, G. Lutzemberger, “Stationary and on-board storage systems to enhance energy and cost efficiency of tramways”, *Journal of Power Sources*, vol. 264, pp. 128-139, 2014.
- [9] A. González-Gil, R. Palacin, P. Batty, “Sustainable urban rail systems: Strategies and technologies for optimal management of regenerative braking energy”, *Energy Conversion and Management*, vol. 75, pp. 374-388, 2013.
- [10] A. Capasso, R. Lamedica, A. Ruvio, G. Giannini, “Eco-friendly urban transport systems. Comparison between energy demands of the trolleybus and tram systems”, *Ingegneria Ferroviaria – CIFI*, April 2014.
- [11] A. Capasso, M. Ceraolo, R. Lamedica, G. Lutzemberger, A. Ruvio, “Modelling and simulation of electric urban transportation systems with energy storage”, 16th International Conference on Environment and Electrical Engineering (EEEIC), 2016 IEEE, 7-10 June 2016, Florence.
- [12] R. Lamedica, A. Ruvio, V. Galdi, G. Graber, P. Sforza, G. Guidibuffarini, C. Spalvieri, “Application of battery auxiliary substations in 3kV railway systems”, 2015 AEIT International Annual Conference.
- [13] D. Iannuzzi, F. Ciccarelli, D. Lauria, “Stationary ultracapacitors storage device for improving energy saving and voltage profile of light transportation networks”, *Transportation Research Part C*, vol. 21, pp. 321-337.

- [14] A. Rufer, D. Hotellier and P. Barrade, “A supercapacitor-based energy storage substation for voltage compensation in weak transportation networks”, *IEEE transactions on Power Delivery*, vol. 19, n. 2, pp. 629-636, 2004.
- [15] M. Ceraolo, G. Lutzemberger, D. Poli, “Aging evaluation of high power lithium cells subjected to micro-cycles”, *Journal of Energy Storage*, vol. 6, pp. 116-124, 2016.
- [16] M. Ceraolo, S. Barsali, G. Lutzemberger, M. Marracci, “Comparison of SC and high-power batteries for use in hybrid vehicles”, *SAE Technical Paper 2009-24-0069*, 2009.
- [17] V. V. Viswanathan and M. Kintner-Meyer, “Second use of transportation batteries: Maximizing the value of batteries for transportation and grid services”, *IEEE Transactions on vehicular technology*, vol. 60, n. 7, pp. 2963-2970, 2011.
- [18] NFP 70E: DC Electrical Safety - Battery systems (art. 320); DC electrical shock & arc flash protection (art. 130).
- [19] F. Ciccarelli, D. Iannuzzi, P. Tricoli, “Control of metro-trains equipped with onboard supercapacitors for energy saving and reduction of power peak demand”, *Transportation Research Part C*, vol. 38, pp. 44-55.
- [20] S. Su, X. Li, T. Tang and Z. Gao, “A subway train timetable optimization approach based on energy-efficient operation strategy”, *IEEE Transactions on Intelligent Transportation Systems*, vol. 14, n. 2, pp. 883-893, 2013.
- [21] Z. Tian, P. Weston, N. Zhao, S. Hillmansen, C. Roberts, L. Chen, “System energy optimisation strategies for metros with regeneration”, *Transportation Research Part C*, vol. 75, pp. 120-135, 2017.
- [22] X. Yang, A. Chen, X. Li, B. Ning, T. Tang, “An energy-efficient scheduling approach to improve the utilization of regenerative energy for metro system”, *Transportation Research Part C*, vol. 57, pp. 13-29, 2015.
- [23] A. Capasso, R. Lamedica, F.M. Gatta, A. Geri, M. Maccioni, A. Ruvio, G. Buffarini, N. Carones, “Individual driving style impact on traction energy consumption in railway lines: A simulation model” *International Symposium on Power Electronics, Electrical Drives, Automation and Motion, SPEEDAM 2016, Capri (Italy)*, 22 June 2016.
- [24] R. R. Liu and I. M. Golovitcher, “Energy-efficient operation of rail vehicles”, *Transportation Research Part A: Policy and Practice*, vol. 37, n. 10, pp. 917-932, 2003.
- [25] D. Cornic, “Efficient recovery of braking energy through a reversible dc substation”, *Electrical Systems for Aircraft, Railway and Ship Propulsion*, pp. 1-9, 2010.
- [26] V. Gelman, “Braking energy recuperation”, *IEEE Vehicular Technology Magazine*, vol. 4, n. 3, pp. 82-89, 2009.
- [27] R. Barrero, X. Tackoen and J. Mierlo, “Stationary or onboard energy storage systems for energy consumption reduction in a metro network”, *Proceedings of the Institution of Mechanical Engineers, Part F: Journal of Rail and Rapid Transit*, vol. 224, pp. 207-225, 2010.

- [28] M. C. Falvo, D. Sbordone, A. Fernandez-Cardador, A. P. Cucala, R. R. Pecharroman and A. Lopez-Lopez, “Energy savings in metro-transit systems: A comparison between operational Italian and Spanish lines”, *Proceedings of the Institution of Mechanical Engineers, Part F: Journal of Rail and Rapid Transit*, vol. 230, n. 2, pp. 345-359, 2016.
- [29] B. T. Kulakowski, J. F. Gardner and J. L. Shearer, “Dynamic modelling and Control of Engineering Systems”, Cambridge University Press, Cambridge, UK, 2007.
- [30] M. Ceraolo, A. Frilli, G. Lutzemberger, L. Pugi, “Regenerative braking in high speed railway applications: analysis by different simulation tools”, 16th International Conference on Environment and Electrical Engineering (EEEIC), 2016 IEEE, 7-10 June 2016, Florence.
- [31] K. Popovici and P. J. Mosterman, “Real-Time Simulation Technologies, Principles, Methodologies, and Applications”, CRC Press, pp. 581-598, 2012.
- [32] P. Fritzson, “Introduction to Modeling and Simulation of Technical and Physical Systems with Modelica”, Wiley-IEEE Press, 2011.
- [33] R. Conti, E. Galardi, E. Meli, D. Nocciolini, L. Pugi and A. Rindi, “Energy and wear optimisation of train longitudinal dynamics and of traction and braking systems”, *Vehicle System Dynamics*, vol. 53, n. 5, pp. 651-671, 2015.
- [34] S. Barsali, P. Bolognesi, M. Ceraolo, M. Funaioli, G. Lutzemberger, “Cyber-Physical Modelling of Railroad Vehicle System using Modelica Simulation Language”, *Railways 2014*, April 2014, Ajaccio.
- [35] M. Ceraolo, G. Lutzemberger, T. Huria, “Experimentally-determined models for high-power lithium batteries”, SAE Technical Paper, 2011.
- [36] A. Pesaran, “Battery choices and potential requirements for Plug-in hybrids”, National Renewable Energy Laboratory (NREL), US Department of Energy Office of Energy Efficiency & Renewable Energy, <https://www.nrel.gov/transportation/assets/pdfs/41328.pdf> (last link verification: 19/12/2017).
- [37] Kokam official documentation: <http://kokam.com/wp-content/uploads/2016/11/2016-Kokam-ESS-Brochure-ver-0.22.compressed.pdf> (last link verification: 19/12/2017).
- [38] UIC 544-1: Brakes - Braking power.
- [39] TSI 1302/2014: Locomotives and passenger rolling stock - LOC & PAS TSI.
- [40] F. Braghin, F. Cheli and G. Galli, “Experimental Assessment of Structure Borne Noise Generated by a Braking Resistor”, *Topics in Dynamics of Civil Structures*, Conference Proceedings of the Society for Experimental Mechanics Series, Volume 4, Springer, New York, NY, 2013.
- [41] Collegio Ferrovieri Italiani official site, http://www.cifi.it/UplDocumenti/AV_Freccia1000/BOMBARDIER%20ETR1000.pdf (last link verification: 19/12/2017).
- [42] Microelettrica Scientifica official site, http://www.microelettrica.com/it/products/resistors/braking/brake_1.jsp (last link verification: 19/12/2017).
- [43] EN, BS. 14363: 2016. Railway applications-Testing for the acceptance of running characteristics of railway vehicles-Testing of running behavior and stationary tests, Annex U, 2016.

[44] EEI equipaggiamenti elettronici industriali official site, <http://www.eei.it/> (last link verification: 19/12/2017).