



UNIVERSITÀ
DEGLI STUDI
FIRENZE

FLORE

Repository istituzionale dell'Università degli Studi di Firenze

On risk-based maintenance: A comprehensive review of three approaches to track the impact of consequence modelling for

Questa è la Versione finale referata (Post print/Accepted manuscript) della seguente pubblicazione:

Original Citation:

On risk-based maintenance: A comprehensive review of three approaches to track the impact of consequence modelling for predicting maintenance actions / Leoni, Leonardo; De Carlo, Filippo; Paltrinieri, Nicola; Sgarbossa, Fabio; BahooToroody, Ahmad. - In: JOURNAL OF LOSS PREVENTION IN THE PROCESS INDUSTRIES. - ISSN 0950-4230. - STAMPA. - 72:(2021), pp. 1-16. [10.1016/j.jlp.2021.104555]

Availability:

The webpage <https://hdl.handle.net/2158/1237738> of the repository was last updated on 2022-02-24T13:41:55Z

Published version:

DOI: 10.1016/j.jlp.2021.104555

Terms of use:

Open Access

La pubblicazione è resa disponibile sotto le norme e i termini della licenza di deposito, secondo quanto stabilito dalla Policy per l'accesso aperto dell'Università degli Studi di Firenze (<https://www.sba.unifi.it/upload/policy-oa-2016-1.pdf>)

Publisher copyright claim:

La data sopra indicata si riferisce all'ultimo aggiornamento della scheda del Repository FloRe - The above-mentioned date refers to the last update of the record in the Institutional Repository FloRe

(Article begins on next page)

On risk-based maintenance: A comprehensive review of three approaches to track the impact of consequence modelling for predicting maintenance actions

Leonardo Leoni^a Filippo De Carlo^a Nicola Paltrinieri^b Fabio Sgarbossa^b Ahmad Bahoo Toroody^c

Department of Industrial Engineering (DIEF), University of Florence, Florence, 50134, Italy

Department of Mechanical and Industrial Engineering, Norwegian University of Science and Technology NTNU, Trondheim, 7031, Norway

Marine and Arctic Technology Group, Department of Mechanical Engineering, Aalto University, 11000, Espoo, Finland

Received 14 April 2021, Accepted 17 May 2021, Available online 25 May 2021.

Abstract

The integrity of the gas distribution network is crucial to guarantee the safety of human beings and the environment, while avoiding significant financial outlay. Since gas plants are progressively increasing near urban areas, a comprehensive tool to conduct maintenance and reduce the risk arising from the operations is required. To this end risk mitigation strategies have played a pivotal role during the last decades. In this paper, a comparison of three Risk-Based Maintenance (RBM) methodologies able to point out the most critical components, is presented. The first developed technique is a four stages Probabilistic Risk Assessment (PRA), characterized by a Hierarchical Bayesian Network (HBN) to perform the occurrence analysis and a Failure Modes, Effects and Criticality Analysis (FMECA) to assess the magnitude of the adverse outcomes. The HBN is adopted to overcome the limitations of traditional probability analysis approaches such as Fault Tree (FT), Event Tree (ET) or Bow-Tie (BT). To define a risk metric the total cost of failure is estimated and subsequently the Cost Risk Priority Number (CRPN) is calculated for each equipment. The second approach is a Quantitative Risk Analysis (QRA) carried out via a software named Safeti (by Den Norske Veritas – German Lloyds DNV-GL). By exploiting standard frequencies and modelling the losses of containment through Safeti, the most compelling devices are determined based on their estimated risk integral percentage. At last, Synergi Plant (another software developed by DNV-GL) is adopted for the third methodology. The software provides a Risk-Based Inspection (RBI) plan, through which the

components are ranked. The proposed study can provide asset manager a concrete aid to focus maintenance efforts on priority apparatus, while assisting them in adopting the most appropriate methodology to their context. To demonstrate the applicability of the approaches and compare the obtained rankings, a Natural Gas Regulating and Measuring Station (NGRMS) is considered as case of study. The results proofed that all the proposed approaches can be implemented for practical application and the choice of the method strongly depends on the available data.

Keywords

Risk-based maintenance; Hierarchical bayesian approach; Quantitative risk analysis; Natural gas distribution network

1. Introduction

During the past years the demand of natural gas has progressively increased, leading to an expansion of the gas distribution network [1]. Since gas installations are scattered across the land, they are constantly threatening the safety of civilians, properties and the environment [2], indeed accidents in transmission pipelines have recently caused losses of life and immoderate damages all over the world [3, 4]. Thus, the evaluation of the risk and the subsequent implementation of preventive measures are fundamental to avoid potential failures and hazardous outcomes.

All the devices are exposed to various deterioration sources such as environmental factors, aging or third-party interference. To preserve the integrity of the equipment adequate maintenance and repair actions must be performed. In chemical industries, dangerous phenomena are indeed mainly generated by asset failures [5], therefore adopting proper maintenance strategies allows to increase the reliability, while reducing the impact of unexpected breakdowns [6].

Over the last decades, maintenance has undergone a severe mutation, moving from a corrective to a proactive or predictive approach. The Corrective Maintenance (CM) is characterized by the lowest engineering contributions since it acts after a failure has occurred. CM used to be the most common practice when maintenance was seen as a necessary evil because of its consumption of resources and manpower, however due to the increase of the safety and reliability requirements, Preventive Maintenance (PM) has acquired a pivotal role. Besides maintenance started to be considered as a vital tool to achieve enterprises' objectives along with pursuing a long-term profitability [7]. The first PM techniques to be introduced were time-based (i.e. based on service age), nevertheless the real operating condition of the equipment is not considered by these strategies, leading to a waste of useful life and higher expenses. To overcome this limitation new maintenance policies such as Condition-

Based Maintenance (CBM) have been introduced. Thanks to the advancement of technology, especially in sensing and monitoring devices, CBM has indeed gained much attention over the last years [8]. While time-based PM schedules maintenance actions at fixed time-intervals, CBM reacts based on available information regarding the condition of a given component [9]. Due to its advantages many researchers have recently focused on CBM application to several fields [10-14]. Kang et al. [11] presented a CBM methodology applied to an offshore wind turbine, exploiting Support Vector Machine (SVM) as core tool to determine whether a device requires maintenance work. Results proofed that the developed methodology reduce the costs up to 32,5% compared to a traditional periodic maintenance.

Despite its demonstrated benefits, CBM conceals some downsides. Tailor-made instrumentation, set-up costs and specific skills are indeed required by any CBM policy [15], moreover data used for failure rate estimation are often scarce. To solve the last issue CBM has been incorporated with RBM [16, 17]. RBM approaches aim at minimizing the probability of system failure, while mitigating its consequences by integrating maintenance activities with safety issues [18]. Thus, RBM plans lead to concentrate maintenance efforts on components associated with high risk, which are inspected and maintained more frequently than low-risk devices [19, 20]. Since the early 2000s RBM has gained popularity both for offshore [21-24] and onshore [25-28] applications. Yeter et al. [24] developed a framework to define the optimum number of monopile wind turbines in an offshore wind farm by minimising the total life cycle cost per energy produced. Different designs were indagated considering capital expenditure, operative expenditure, decommissioning expenditure and a relationship between the manufacturing cost and the structural safety. This work revealed that 60 installations guarantee the optimum life cycle cost per energy produced, while high-quality inspections for fewer wind turbines and low-quality inspections for more wind turbines are suggested during the first visits and the last visits respectively.

Although the risk arising from the operations can never be eliminated, an effective RBM policy can bring the overall risk under a tolerable threshold level, by decreasing the likelihood of accidents. To this end many works were presented during the past years [29-32]. The study developed by Khan and Haddara [31] proposes a RBM strategy for designing the optimum maintenance plan via a reverse FT analysis. The five most critical units of an ethylene production plant were considered and for each detected failure scenarios the overall risk is calculated. The results regarded the ethylene transportation pipeline as the most critical group since both the individual and societal risks exceeded the acceptable risk criteria. A more recent research by Pui et al. [30] proposes a similar method for an offshore pressure drilling, adopting a Bayesian Network (BN) instead of a FT. By setting the

lowest risk level the posterior probabilities are found and they are used to estimate the maintenance interval for each critical device.

Compared to other traditional techniques, the BN is more suited for reasoning under uncertainty, especially when data sources are limited [33]. Besides conventional tools are static [34] and unable to represent conditional dependencies [35]. The recent development in open source Markov Chain Monte Carlo (MCMC) sampling software i.e. OpenBUGS have led to a wider adoption of HBN for engineering applications [36]. HBN has indeed been exploited by many researchers to perform PRA [37, 38], condition monitoring [39, 40] and reliability assessment [41, 42]. Very recently, BahooToroody et al. [39] adopted a HBN integrated with a generalized linear model for studying the trend of the process variables of a NGRMS. The developed methodology evaluates the reliability of the system in real time, assisting the users during the remediation program. A previous work by BahooToroody et al. [41] presented a comparison between a Bayesian inference with hierarchical structure and maximum likelihood estimation in estimating the failure rate of operating devices, while considering time-dependency. The results depicted that HBN model is more accurate than the maximum likelihood estimation.

Choosing the proper maintenance policy is regarded as a difficult task and it depends on the maintenance skills and equipment available inside a given organization [43], moreover enterprises work with finite resources, hence maintenance should be cost effective. Since Oil & Gas industry is classified as a high-risk field due to the handled hazardous substance, maintenance strategies must also include safety aspects. Thus, determining the most critical devices is essential to guarantee the safety, while staying within the budget. Despite all the ongoing efforts on asset integrity management of the natural gas distribution system there is still space for a comprehensive review of RBM methodologies. Consequently, the main objective of this paper is comparing three RBM approaches that provide a criticality ranking and prioritize maintenance actions for the devices operating inside a NGRMS. In the first method a HBM analysis is implemented to deal with the uncertainties arising from the process and predict the posterior probabilities of failure, while the severity is assessed via a FMECA. The second and the third approaches are respectively a QRA conducted via Safeti and a RBI performed via Synergi Plant. The models are applied to an actual example of stochastic process of a NGRMS near Florence, Italy.

1.1 Hierarchical Bayesian Modelling

“Data” collected by a process or other sources (i.e. database or literature) represent the starting point of almost every statistical inference. First evaluating, manipulating and organizing “Data” lead to “Information”, then “Knowledge” is acquired by gathering “Information”. At last drawing a

The source models calculate the amount of the hazardous substance released along with defining its phase, while the dispersion models are tasked with estimating the concentration of the released mass both in time and space. Depending on the features of the hazardous material and its phase, the consequence models determine the impact of the phenomena (i.e. jet fire, pool fire, vapor cloud explosion, flash fire, fireball) caused by the loss of containment. At last, the damage models assess the risk based on a chosen metric. (e.g. probability of death).

Implementing a quantitative risk is considered a difficult task that is usually performed through specific softwares such as Phast & Safeti [48], which adopts standard source, dispersion and consequence models to carry out the QRA. The several benefits possessed by Safeti, resulted in a widespread use of the software for complex engineering applications. Examples include risk analysis of supercritical fluid extraction [49], simulation of an explosion [50-52], and leakage of hazardous substance [53].

The remainder of the paper is organized as follows; section 2 illustrates the stages and steps of the developed methodology. Section 3 describes the implementation of the methodologies to a case study, while section 4 presents the discussion of the results. At last in section 5 conclusions are drawn.

2. Developed methodology

This paper aims at comparing three practical RBM approaches capable of prioritizing maintenance actions for hazardous plants. The strengths and weaknesses of each framework are highlighted through a sensitivity analysis, which also points out the best combination of the three methodologies. The outcome of this research will assist maintenance managers during the development of the maintenance plan, by guiding the choice of the methodology that best fits their needs.

2.1 Hierarchical Bayesian Modelling and CRPN

The first technique has been recently developed by Leoni et al. [54] and it consists of four stages as illustrated in Fig. 2.

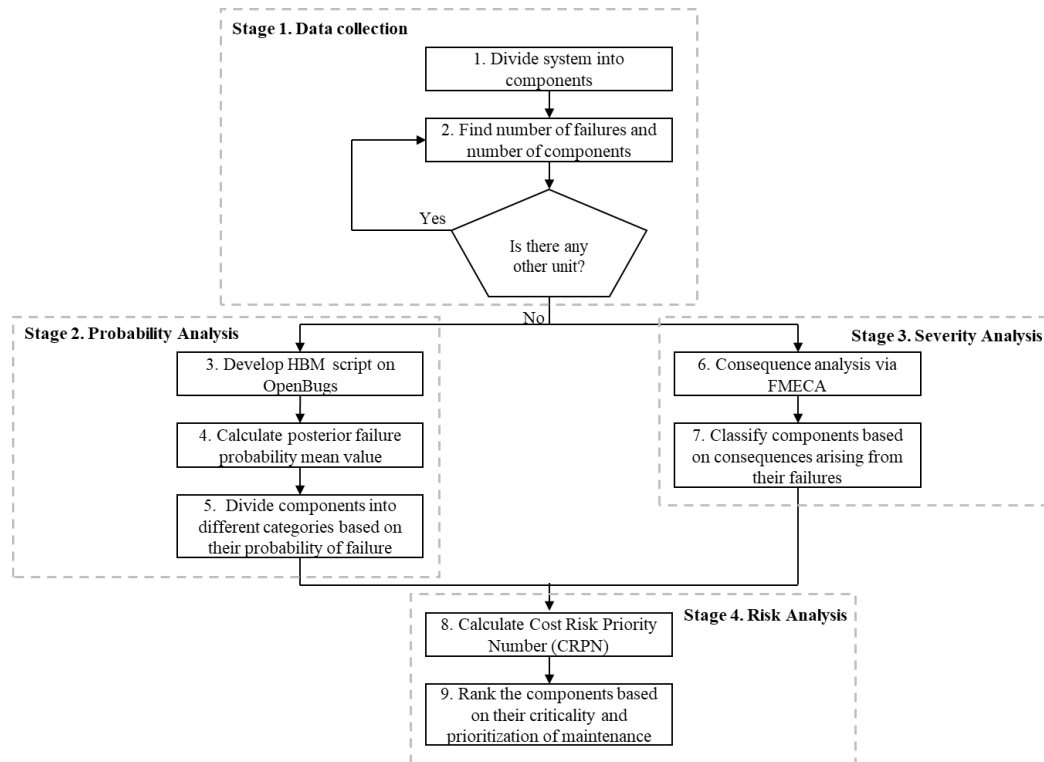

Fig. 2. Developed RBM framework methodology with hierarchical Bayesian inference

The first phase is accounted as data collection (Stage 1), therefore data to implement the subsequent steps are gathered. The system is broken down into its main components, then for each component the number of failures that has occurred during a specific timeframe is found.

During the probability analysis (Stage 2.) a HBM is implemented through a script in OpenBugs. Via HBM a binomial function is specified and the posterior distributions of the probability of failure are estimated. Subsequently for each distribution the mean value is extracted. The mean posterior probabilities of failure are eventually exploited to classify the devices into ten occurrence categories.

Next a FMECA is adopted to conduct the severity analysis (Stage 3). During this stage the outcomes of potential failures are evaluated and then used to assign to each component a level of severity. As in the previous work ten severity classes are considered for this study.

At last data about costs are provided by expert judgments and useful information. Through a combination of cost, occurrence and severity the CRPN is calculated for each component and the risk analysis (Stage 4) is implemented. The CRPN is indeed used for ranking the components, pointing out the most critical ones.

2.2 Quantitative Risk Analysis with Safeti

The second approach is a QRA carried out via a software named Safeti. The flowchart of this method is represented in Fig. 3.

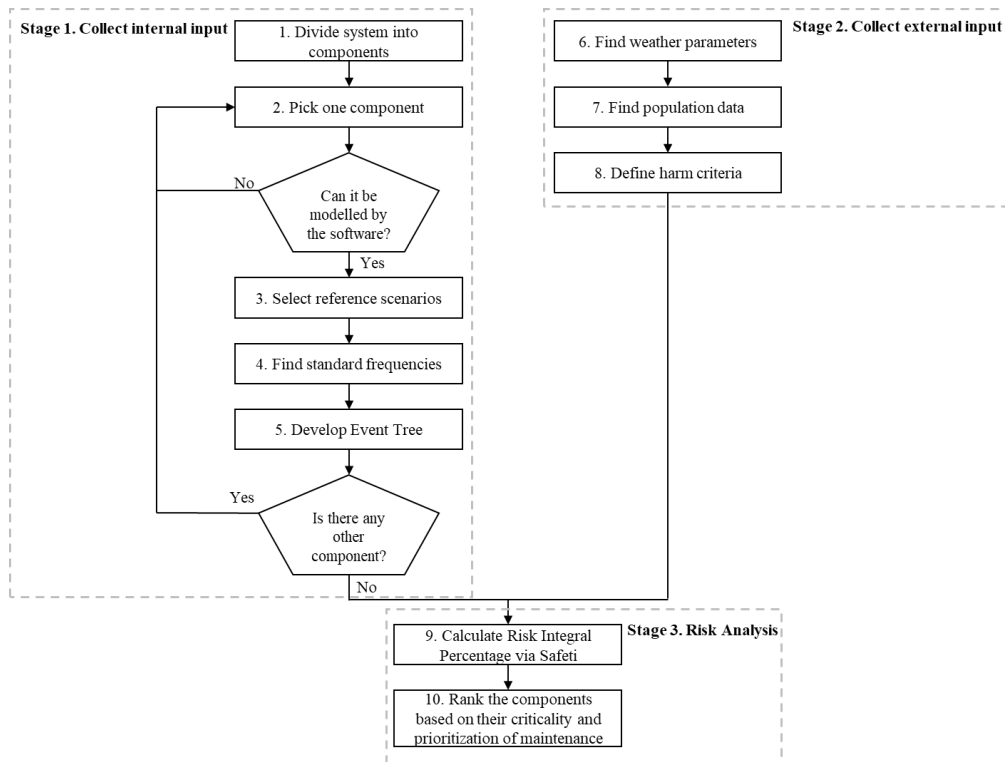

Fig. 3. Developed RBM framework methodology with Safeti

As in the previous framework, the first step consists in defining the system and breaking it down into its most relevant components. Each component is then studied to determine its features (i.e. operating conditions and dimensions) and the handled hazardous substances. Next reference scenarios are assigned to every device that can be modelled by the software and subsequently for each chosen reference scenario standard frequencies are found in literature. At last ETs are developed for the reference scenarios. The inputs that are inherently related to the plant are provided by this part of the approach (Stage 1).

During the second phase (Stage 2.) the information, that are not directly related to the plant, are procured. At first weather parameters such as Pasquill Stability and windspeed, required by the dispersion models, are gathered. Then population density and harm criteria, which are crucial for estimating the risk of each scenario, are determined.

All the inputs collected by the previous stages are inserted into Safeti to perform the QRA (Stage 3). The components are finally ranked based on the risk integral percentage obtained by the calculation. The risk integral percentage of a certain equipment is estimated by summing up the risk integral percentage of the scenarios related to that equipment.

2.3 Risk-Based Inspection with Synergi Plant

The sequence of the proposed methodology is showed by Fig. 4. The main tool adopted for the third approach is Synergi Plant, which is a software developed by DNV-GL for scheduling inspections based on the level of risk.

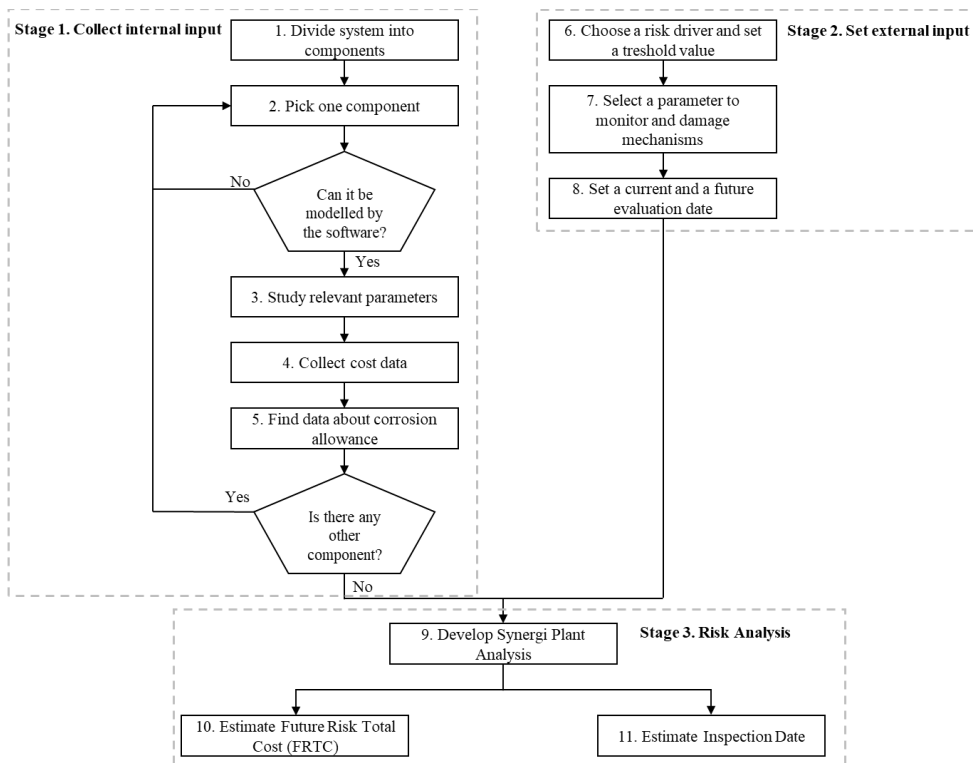

Fig. 4. Developed RBM framework methodology with Synergi Plant

During the first phase (Stage 1) the system is initially decomposed into its main components, then each device that can be modelled by the software is investigated to collect data about its relevant parameters such as operating condition, material or wall thickness. Next corrosion allowance and cost data are provided to perform the analysis.

As in every RBI a risk metric and a risk target are defined, indeed the inspection is scheduled when a fixed risk threshold is reached. Besides a parameter that can be monitored continuously or inspected periodically and that is related to the risk driver is chosen, as long with its damage mechanism. To conclude this part (Stage 2) a current and a future evaluation dates are set.

The risk analysis (Stage 3) is finally carried out via Synergi Plant. The most critical components are pinpointed based on two relevant parameters: i) the inspection date and ii) the Future Risk Total Cost (FRTC) without performing inspection.

3. Application of the methodologies: a case study

To illustrate the application of the proposed approaches, NGRMS (Fig. 5.) is chosen as a case of study. NGRMS is indeed deemed as a hazardous installation since toxic and flammable substances are processed. Each plant has twelve main components divided into four groups as listed in Table 1.

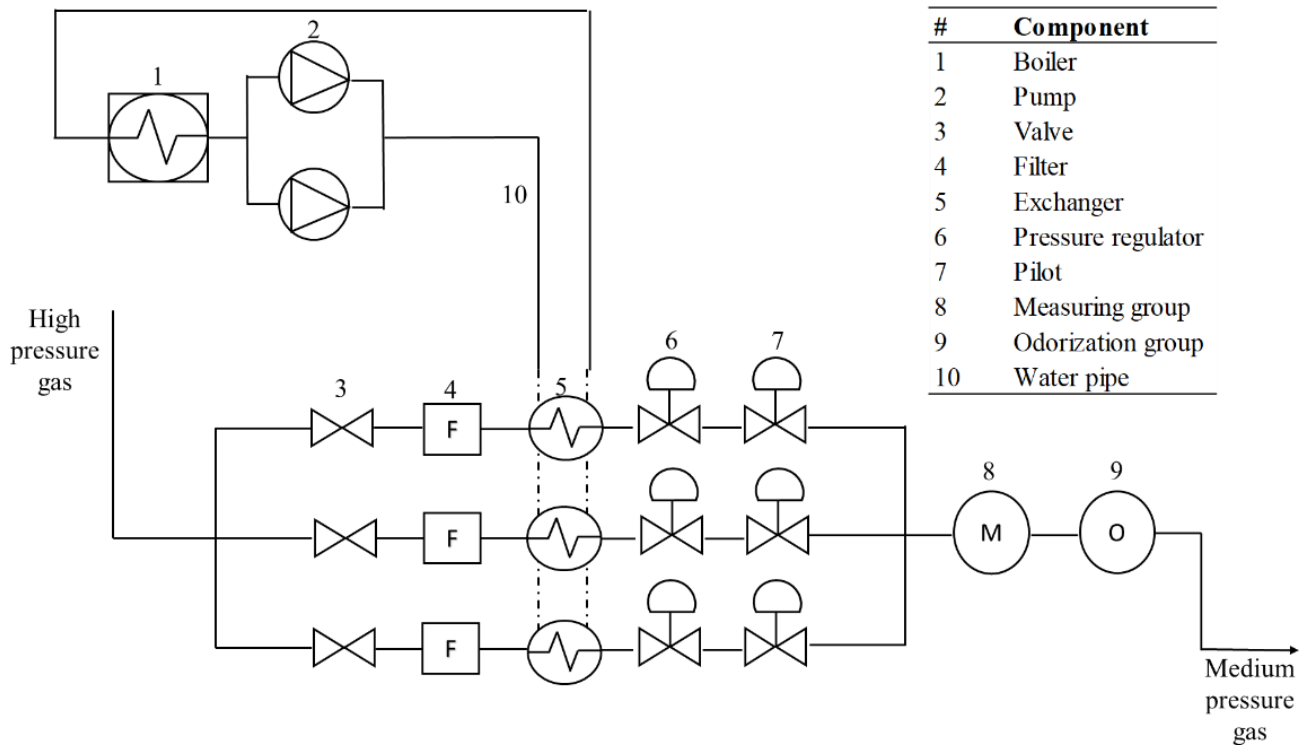

Fig. 5. Schematic architecture of a typical NGRMS

Table 1

Main groups and components of NGRMS

Group	Component
Reduction	Pressure regulator
	Pilot
	Filter
Measuring	Pressure and temperature gauge
	Calculator
	Meter
	Remote control system
Odorization	THT tank
	THT pipelines
Preheating	Pump
	Boiler
	Water pipe

The pressure regulator is designed to reduce the pressure of the gas flow by varying the cross-sectional flow area. For faster and more precise change of the pressure the pilot is also involved. Pressure regulator and pilot are tasked with adapting the pressure of the gas flow to the downstream utilities. The filter is placed upstream the pressure regulator, indeed it has to block the access of solid and liquid impurities that could damage the subsequent devices. Before entering inside the pressure regulator the gas temperature is increased by an exchanger in which circulated pre-heated water. This process is required to avoid the formation of ice since the temperature decreases along with the reduction of pressure. The most relevant parameters of the gas flow are assessed by the measuring group, while a precise quantity of odorizer, usually tetrahydrothiophene (THT), is added by the odorization group.

3.1 Application of CRPN method to NGRMS

First data regarding the number of failures and statistical population (Table 2) of each component are acquired. The considered data result from the operation of 59 NGRMSs during the past 6 years. Exploiting the aforementioned values and considering the relationships among the components a HBM was developed. To this end a binomial distribution was chosen to model the probability of failure, while a beta function was adopted as the prior distribution. The developed BN is showed by Fig. 6, where X denotes the number of failures and n stands for the population number. p is the unknown parameter of interest (i.e. the probability of failure) whose posterior distribution is provided by the HBM. At last α and β represent the hyper-parameters.

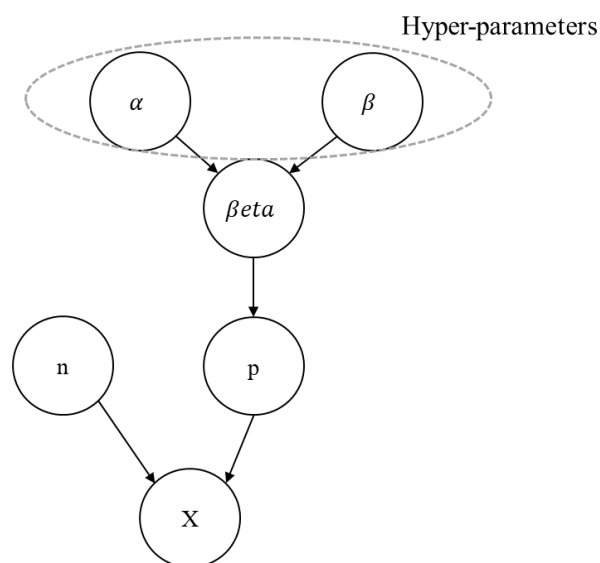

Fig. 6. Adopted BN to estimate the posterior probabilities of failure

Following the previous research the model was implemented through OpenBUGS software adopting a Jeffrey Prior, $\text{dbeta}(0.5, 0.5)$, and three Markov Chain, each of which with 10^5 iterations. The Bayesian inference predicted the posterior distribution from which the mean values listed in Table 2 are extracted.

Table 2

Number of failures, population number and posterior mean probability of failure of NGRMS' main components

Component	Number of failures (x)	Number of components	Population (n)	Posterior mean probability of failure
Pressure Regulator	17	248	543,120	3.46E-05
Pilots	6	496	1,086,240	1.29E-05
Filter	12	124	271,560	5.36E-05
RCS	19	59	129,210	1.52E-04
Meter	7	108	236,520	4.23E-05
PTG	65	59	129,210	5.09E-04
Calculator	47	59	129,210	1.61E-04
THT tank	7	59	129,210	6.80E-05
THT pipelines	3	59	129,210	3.57E-05
Pump	38	108	236,520	1.69E-04
Boiler	23	108	236,520	1.07E-04
Water pipe	25	59	129,210	2.07E-04

Considering the results depicted by the calculation (Table 2) a level of occurrence is assigned to every component based on Table 3. Subsequently to perform the severity analysis the consequences of potential failure are evaluated via FMECA and each component is then inserted into Table 4.

Table 3

Likelihood criteria ranking

Occurrence	Occurrence probability	Component
1	<1 in 30,000	Pilot
2	1 in 25,000	Pressure regulator, THT pipelines
3	1 in 20,000	Meter
4	1 in 10,000	Filter, THT tank
5	1 in 5,000	RCS, calculator, boiler, pump
6	1 in 3,000	Water pipe
7	1 in 2,000	
8	1 in 1,000	PTG
9	1 in 500	

Table 4

Severity criteria ranking

Severity	Severity of effect	Component
1	No effect	
2	Very minor effect on production	Water pipe, PTG
3	Minor effect on production	Pump, meter, calculator
4	Small effect on production, repair not required	
5	Moderate effect on production, repair required	Boiler
6	Component performance is degraded	RCS
7	The component is severely affected, NGRMS may not operate	Filter
8	The component is inoperable with loss of primary function	Pilot, pressure regulator
9	Failure involves hazardous outcomes	THT tank, THT pipelines
10	Failure is hazardous and occurs without warning, NGRMS operation is suspended	

Introducing the total cost of failure (C) the CRPN is finally calculated using Eq.

$$CRPN = C * S * O$$

Where O and S are integer given by Table 3 and Table 4 respectively. O represents the level of occurrence, while S refers to the severity class. C denotes the dimensionless cost obtained through the estimated pump failure cost of 10,000\$. Pump is the component characterized by the lowest total failure cost, while the failure of the odorization devices turned out to be the most expensive. Through the calculation of CRPN via Eq, the components are eventually ranked based on their criticality (Table 5).

Table 5

Obtained ranking through the CRPN methodology

Ranking	Component	O	S	Dimensionless Cost (C)	CRPN
1	THT tank	4	9	33	1188
2	THT pipelines	2	9	33	594
3	RCS	5	6	6	180
4	Boiler	5	5	5	125
5	Water pipe	8	2	7	112
6	Meter	3	3	10	90
7	Pressure Regulator	2	8	4	64

8	Filter	4	7	2	56
9	Pilot	1	8	4	32
10	Calculator	5	3	2	30
11	PTG	6	2	2	24
12	Pump	5	3	1	15

With a CRPN equal to 1188 the THT tank is regarded as the most critical device, followed by the THT pipeline. Their CRPNs arise mainly from the severity level (9), indeed potential leakage can plague the air of a vast area as well as causing dangerous phenomena such as pool fire or explosions. It transpires that the main maintenance efforts must be directed towards the odorization group to avoid financial losses. The third and the fourth highest CRPNs are associated to the RCS and the boiler respectively, but in contrast with the aforementioned equipment, the occurrence plays a relevant role. On the other side the pilot, the calculator, the PTG and the pump are evaluated as the least critical equipment, since their CRPNs are lower than 40.

3.2 Application of QRA via Safeti to NGRMS

Safeti is a professional simulator for consequence modelling and it is regarded as one of the most precise and accurate tools for implementing QRA of plants that process hazardous substances. An in-depth knowledge of the process, the plant layout, the involved equipment, the handled hazardous substances, the geographical location, the weather conditions and the population surrounding the hazardous installation is required by any QRA.

Water, methane and THT are processed by the components of a NGRMS. Both natural gas and odorization gas are deemed as hazardous substances due to their toxic and flammable properties and they are respectively handled by the reduction unit and the odorization group, while the devices belonging to the pre-heating group are tasked with the water treatments. The components considered during this approach are listed by Table 6, which also reports relevant information for the analysis.

Table 6

Operating condition, features, handled hazardous substance and its features of the considered NGRMS' devices

Equipment	Size inlet diameter [mm]	Service pressure range [bar]	Service temperature range[°C]	Substance handled	Substance state	Mass flow [m3/h]
Pressure regulator	101.6 mm	24-4.5	0-30	Methane	Gas	2000
Filter	101.6mm	24	0-30	Methane	Gas	2000
THT pipelines	50.8 mm	4.5	0-30	THT	Gas	200
Pump	50.8mm	1.013	0-100	Water	Liquid	10
Boiler	50.8mm	0.02	0-100	Water	Liquid	10

In addition to the equipment outlined by Table, the THT tank has also been taken into account for the QRA. The odorizer is indeed stored inside a horizontal cylindrical tank, which can contain up to 1,000 litres of gas. On the other side the pilot and the measurement devices cannot be modelled by Safeti due to the absence of similar apparatus inside the software.

After a brief analysis of the plant, the fault scenarios are investigated. In any QRA a hazardous event is represented by a loss of containment of a hazardous substance. Since resources are limited, a reduced number of scenarios (Table 7) is chosen. The frequencies of the considered reference scenarios are acquired through expert judgment and available literature [55, 56].

Table 7

Selected reference scenarios and their respective frequencies

Component	Scenario no.	Scenario Category	Frequency [event/year]
Pressure regulator	1	10mm leakage	1.2E-04
	2	25mm leakage	1.1E-05
	3	50mm leakage	1.1E-05
	4	Catastrophic rupture	3.2E-06
Filter	5	10mm leakage	8.9E-05
	6	50mm leakage	6.4E-06
	7	Catastrophic rupture	1.3E-07
THT tank	8	10mm leakage	1.2E-04
	9	25mm leakage	1.1E-05
	10	50mm leakage	1.1E-05
	11	Catastrophic rupture	3.2E-06
THT pipeline	12	10% diameter leakage	4.8E-05
	13	20% diameter leakage	2.5E-05
	14	Full bore rupture	1.2E-06
Pump	15	10% diameter leakage	1.5E-05
	16	20% diameter leakage	7.8E-06
	17	Full bore rupture	1.7E-06
Boiler	18	10% diameter leakage	1E-05
	19	20% diameter leakage	5.2E-06
	20	Full bore rupture	2.6E-07
Water pipe	21	10% diameter leakage	6.5E-05
	22	20% diameter leakage	3.4E-05
	23	Full bore rupture	1.7E-06

To determine the consequences arising from a certain loss of containment an ET is built for each reference scenario. The ETs are required for a deeper understanding of the hazardous events and its

most relevant outcomes. To perform this step ARAMIS' procedure is adopted, accordingly the development of each ET is led by the risk properties of the related hazardous substance and its phase. For instance, flammable and toxic properties are associated to the THT, which is stored in liquid phase. Consequently, a leakage or a catastrophic rupture involving the odorizer may result in a pool formation that could eventually take fire other than provoking environmental damage and pollution. On the other side methane, which is also known as a toxic and flammable substance, is handled in gas state. As a result, a catastrophic rupture (instantaneous release) of any component that processes methane leads to a gas puff, while a gas jet is generated by a leakage. Besides in case of immediate ignition the gas jet will be ignited, otherwise with delayed ignition a Vapor Cloud Explosion (VCE) or a Flash Fire might take place depending on the congestion of the released mass. The ET built for the catastrophic rupture of the pressure regulator is illustrated in Fig. 7 as an example.

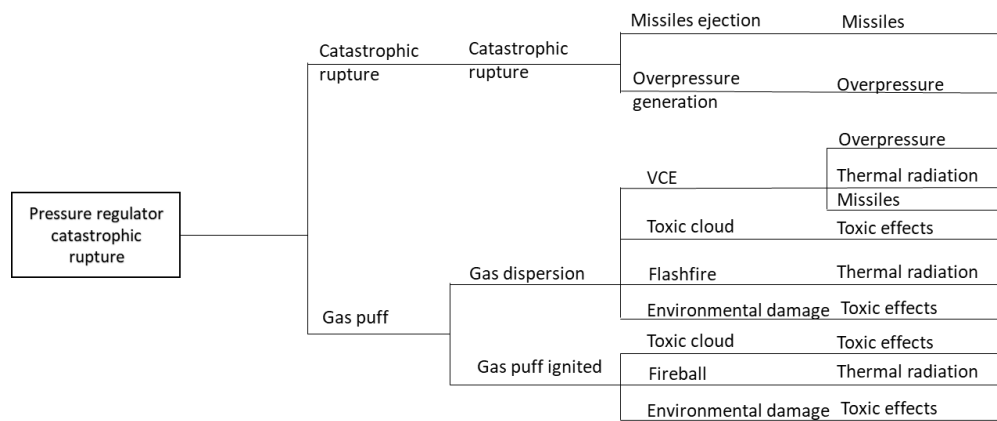

Fig. 7. Developed ET for the catastrophic rupture of the pressure regulator

In accordance with the approach presented by Fig. 3 weather parameters are gathered. Two weather conditions (June and December) are considered for this study and their summarised information are listed in Table 8. Another pivotal input related to the weather condition and required particularly by the dispersion model is represented by the probabilities of wind direction (Fig. 8).

Table 8

Most relevant atmospheric parameters for June and December

Atmospheric parameter	June	December
Wind speed [m/s]	3	2.06
Temperature [°C]	27	9
Relative Humidity	68%	78%
Incoming radiation	Strong	Slightly
Pasquill stability	A	C

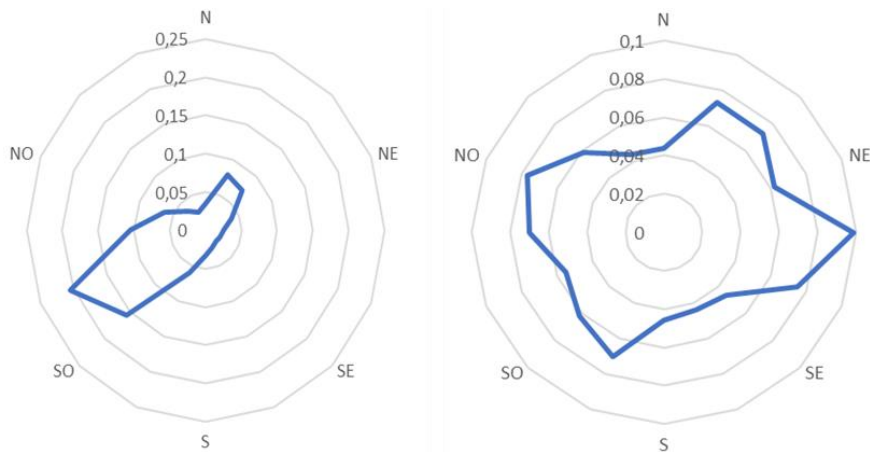

Fig. 8 Probability distribution of wind directions in June (left) and December (right)

Data regarding population are also required by the software to implement the risk analysis. The considered NGRMS is located in a suburban area of Sesto Fiorentino, a town near Florence. Because of the presence of two industrial plants and some agricultural sheds, approximately 80 people are assumed to be in the vicinity of the hazardous installation.

At last the harm criteria needed to calculate the risk integral percentage are chosen. Four different thermal radiation for jet fire, fireball and pool fire were considered: 1.6, 4, 12.5 and $37.5 \text{ kW}/\text{m}^2$. Regarding the flash fire the population inside the Lower Flammability Level (LFL) will die with 100% probability due to direct contact with the flames, while people situated in $\frac{1}{2}$ LFL will suffer only inhalation effect. Four levels of overpressure were chosen to evaluate the impact of the VCE. The adopted evaluation criteria are illustrated by Table 9.

Table 9

Adopted harm criteria for the implementation of the QRA

Incident outcome	Criteria	Damage	Fatality
Flash Fire	LFL	Imminent Death	100%
	1/2LFL	Inhalation Effect	0
Pool fire, Fireball, Jet Fire	1.6 (kW/m^2)	Safe distance	0
	4 (kW/m^2)	Second degree burn	1%
	12.5 (kW/m^2)	Melting of plastic tubing	10%
	36 (kW/m^2)	Damage to process equipment, death	100%
VCE	0.0103 bar	Glass shatter	0%
	0.02068 bar	Safe distance	0%

0.1379 bar	Partial collapse of roof and houses	5%
0.2068 bar	Serious injury, Fathality	100%

After inserting all the required data into Safeti the simulation is run and subsequently useful information for the design or the revamping of the plant are provided by the software. Considering as an example the tenth scenario (i.e. 50mm leakage for the THT tank) some results will be discussed. The calculation revealed that in case of late pool fire, which assumes the largest pool diameter, the maximum peak of the radiation is 80 kW/m^2 and it occurs during December at a downwind distance between 20m and 30m. The maximum radiation level is a little bit lower in June and it is recorded between 32m and 40m. For both months the radiation level falls to 0 after 70m. The variation of the radiation level with the distance is illustrated in Fig. 9.

Fig. 10 represents the iso-intensity level contours of the radiation both downwind and cross wind for a late pool fire in June. The lethality area (inside 37.5 kW/m^2 iso intensity contour) is situated between 30m and 45m in downwind direction, while the safe area (outside 1.6 kW/m^2 iso intensity contour) begins after more than 70m downwind. Unprotected people who reside in the zone between 1.6 kW/m^2 and 4 kW/m^2 are expected to suffer from second degree burn.

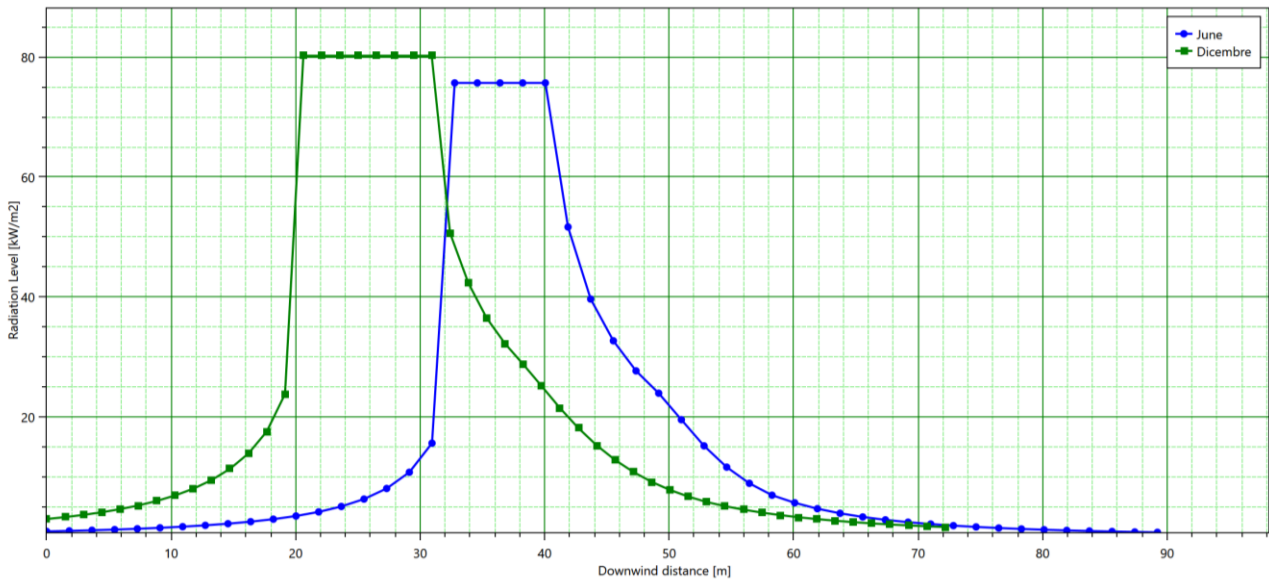

Fig. 9. Radiation level of a late pool fire generated by a 50mm leakage from the THT tank

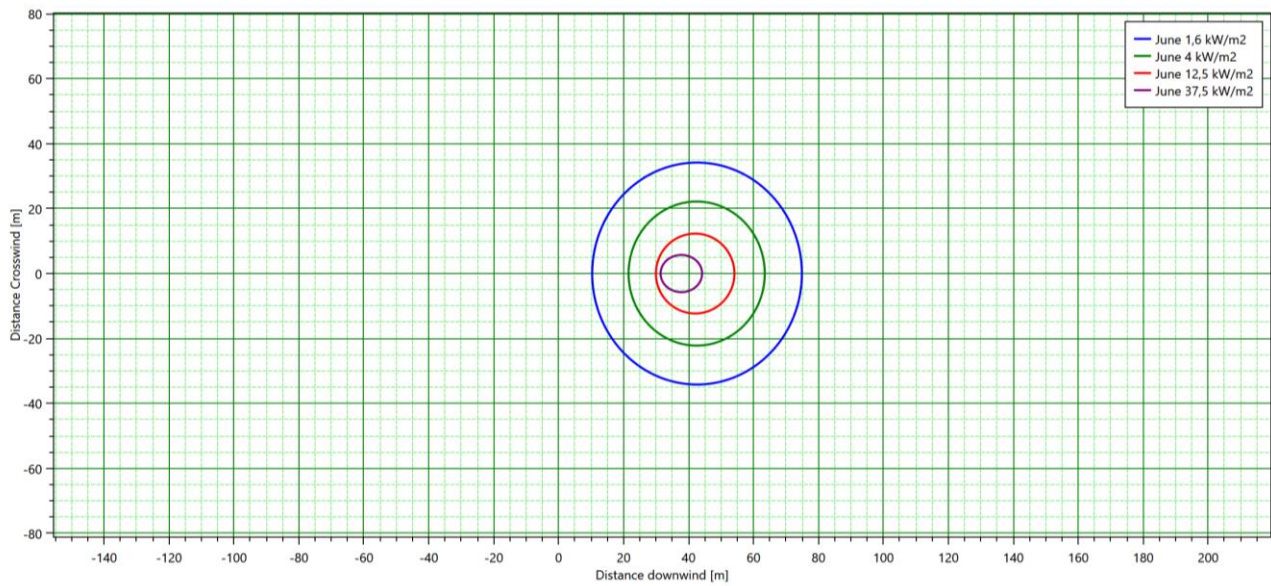

Fig. 10 Iso-intensity curves of a late pool fire generated by a 50mm leakage from the THT tank

Scrutinizing the outcomes of the overpressure generated by a VCE in the worst-case scenario depicted that the lethality overpressure (0.2068bar) is not reached in June (Fig. 11). On the other side the minor injury curve (0.1379bar iso-overpressure contour) is limited to a small area, while the safe distance (0.02068bar iso-overpressure contour) begins slightly before 100m downwind and 80m crosswind. The safe distance is slightly different between June and December as reported by Table 10. In June a person is indeed regarded as safe in a location 98m far from the hazardous installation, while for December the safe distance is about 10m shorter. The first value is more restrictive, therefore it must be adopted when new facilities or houses are built. In both weather conditions buildings situated 30m far from the plant could suffer serious damages, while people could get injured, with a slightly probability of death equal to 5%.

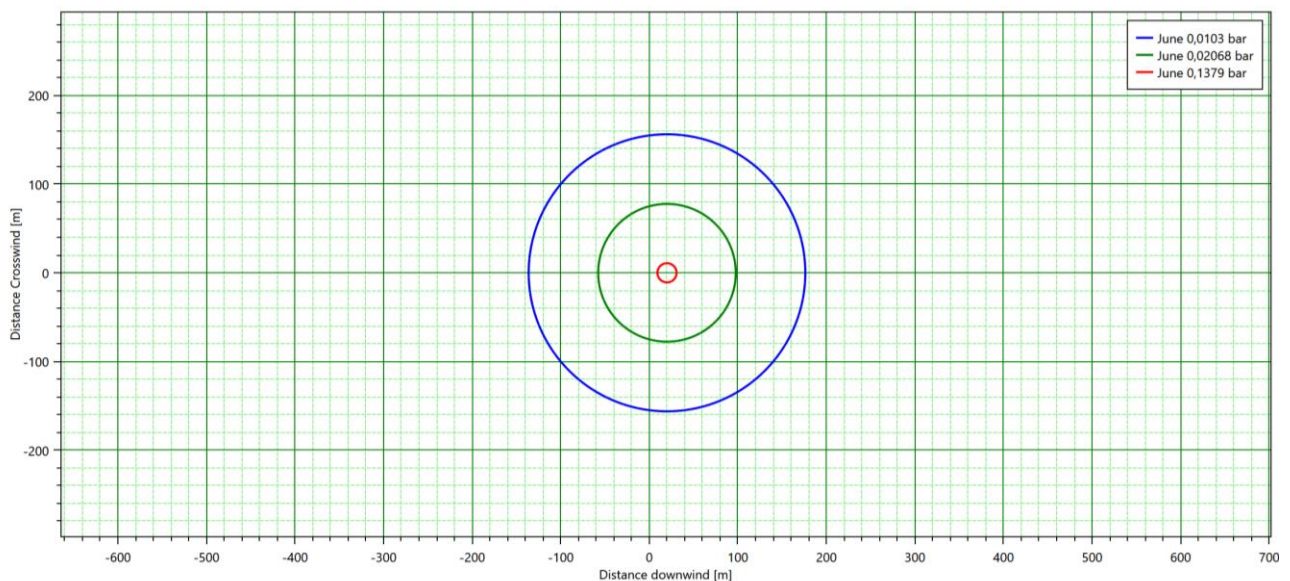

Fig. 11 Iso-overpressure curves of the worst-case scenario explosion generated by a 50mm leakage from the THT tank

Table 10

Location from the installation where the reference overpressures are reached for June and December

		Weather	
		June	December
		Damage distance[m]	
Overpressure[bar]	0.0103	177	155
	0.02068	98	87
	0.1379	31	29
	0.2068	Not reachable	Not Reachable

To highlight the most critical components, whose maintenance must be a priority, the risk integral percentage is adopted as a driver. Once the aforementioned risk metric has been calculated via Safeti for each loss of containment, the risk integral percentage of a certain component is obtained by summing up the risk integral percentages of the related scenarios. Based on the estimated risk integral percentage the devices are ranked as showed by Table 11.

Table 11

Ranking based on the risk integral percentage obtained via the Safeti methodology

Ranking	Component	Risk integral percentage
1	Filter	77.57
2	Pressure Regulator	11.48
3	THT tank	9.49
4	THT pipe	1.45
5	Water pipe	0
5	Pump	0
5	Boiler	0

With a striking difference of the risk integral percentage the filter is evaluated as the most critical component, followed by the pressure regulator with an estimated risk integral percentage of 11.48. Accordingly, the most critical group is the pressure regulation group, since its two components are the most critical ones, thus their maintenance has the priority. On the opposite side the pre-heating devices are the less critical with a null risk integral, indeed leakage or catastrophic rupture provoke

slightly burn in the worst-case scenario. The odorization group is the second most critical unit, with THT tank as the component characterized by the highest risk integral percentage.

3.3 RBI plan with Synergi Plant

Table 12 shows the components considered for the third technique along with their respective cost data, provided by expert judgment. The outage cost denotes the cost arising from the nonworking component, while the environmental clean-up cost refers to the cost sustained by the company for erasing the pollution after a leakage. The THT tank and the THT pipelines are characterized by the highest environmental clean-up cost because a loss of containment could plague a huge area. On the other side the water components have a null environmental clean-up cost, indeed water escapes do not require any special procedure. The outage cost is higher for the odorizer unit rather than the methane group. The Filter, the THT tank and the THT pipelines have the same worst-case equipment damage cost of 1,500,000€, which represents the plant cost, indeed as a consequence of leakage or a catastrophic rupture, all plant could get engulfed in an explosion and therefore destroyed. Another cost required by the software is the death/injury cost, which is assumed equal to 10,000,000€. At last the equipment costs are needed to perform the analysis. The data illustrated by Table 13 reveal that the devices of the methane unit are twice and third time more expensive than the odorization and water components respectively.

Table 12

Outage cost, environmental clean-up cost and worst-case equipment damage for the considered NGRMS' components

Component	Outage cost [\$/h]	Environmental clean-up cost [\$/m³]	Worst-case equipment damage [\$]
Filter	5,000	1,000	1,500,000
THT tank	10,000	10,000	1,500,000
THT pipelines	10,000	1,0000	1,500,000
Pump	2,000	0	10.000
Boiler	2,000	0	10.000
Water pipe	2,000	0	8.000

Table 13

Equipment cost of methane, water and odorization unit

Unit	Equipment cost[\$/m²]
Methane	10,000

Odorization	5,000
Water	3,000

To conduct the analysis three reference dates are set: i) the service start date, ii) the current evaluation date and iii) the future evaluation date. For this study the service start date is fixed at 01/01/2016, while the current evaluation date is 6 years later and finally the 07/11/2041 is chosen as the future evaluation date.

The likelihood of the reference scenarios (small, medium, large leakage and rupture) are determined by the software following the API-BRD 581 standards, while the consequences are evaluated with a semiquantitative approach characterized by the combination of three factors: i) material escape, ii) personnel injury and iii) business impact. Considering the filter as an example, some relevant outputs produced by the software at this stage are illustrated by Table 14. The outage time, the outage cost, the equipment damage cost and the safety cost are provided for four different scenarios. The analysis depicted that the outage time for a small hole is two days, while eight days more are required to repair a medium hole. Twelve days is instead the downtime period for a large hole or a catastrophic rupture. The outage cost represents the major cost item, indeed methane is quite volatile, thus the environmental impact is usually low unless the gas gets ignited. Considering the safety cost the company is estimated to sustain an expense of 5,000\$ in case of a small hole, while a catastrophic rupture or a large leakage generate a financial outlay of 175,000\$.

Table 14

Outage time, outage cost, equipment damage cost and safety cost for the filter

Hole Size	Outage time [day]	Outage cost [\$]	Equipment damage cost [\$]	Safety cost [\$]	Total cost [\$]
Small Hole	1.99	239,389	24,581	4,805	268,776
Medium Hole	10.23	1,227,821	401,470	87,221	1,759,338
Large Hole	14	1,680,681	686,435	174,789	2,656,974
Rupture	14.08	1,689,264	692,435	174,789	2,672,982

The choice of a risk metric along with a risk threshold is required to develop a RBI plan. The Risk Total Cost (RTC) is adopted as a driver and its maximum tolerable value is set at 20,000\$/AvegYear. For scheduling the inspections, the width is chosen as the parameter to be monitored, while the external corrosion is considered as damage mechanism. The components are made out of carbon steel,

in particular pipes are made of API 5L GR B. THT pipeline has a 2.9mm width, while the inlet pipe of the filter is characterized by a width of 3.2mm. The THT tank is a horizontal cylinder with 1400mm length and 690mm diameter while its width is 3mm. The corrosion allowance is assumed equal to 1.5mm [57] while the corrosion rate calculated by the software is adopted.

Once the required data are inserted into Synergi Plant the inspection plan is obtained, then the components are ranked based on their respective inspection date as showed by Table 15. The software calculates also the Current Risk Total Cost (CRTC), which is evaluated in the current date, the Future Risk Total Cost With Inspection (FRTC W.I.), estimated in the future evaluation date considering the inspection plan, and the Future Risk Total Cost Without Inspection (FRTC WO.I.), which refers to the same date as the previous cost, but without taking into account the inspections planned. The CRTC is influenced by the timespan between the service start date and the current evaluation date, while the FRTC W.I. and FRTC WO.I. are driven by the future evaluation date and the potential inspections between the current and the future evaluation day.

Table 15

Ranking obtained via Synergi Plant approach and CRTC, FRTC W.I. and FRTC WO.I. calculated for each component

Component	Ranking	Future inspection date	CRTC [\$/AvegYear]	FRTC W. I. [\$/AvegYear]	FRTC WO. I. [\$/AvegYear]
Filter	1	23/01/2025	564	20,920	134,927
THT pipeline	2	24/07/2025	701	16,211	81,298
THT tank	3	14/01/2027	550	39,372	892,621
Boiler	4	16/10/2050	652	15,668	15,668
Water pipe	5	16/10/2050	652	15,668	15,668
Pump	6	16/10/2050	652	15,668	15,668

The calculation highlighted that the most critical component is the filter, whose inspection is scheduled on January 23rd, 2025. The inspection allows to reduce the FRTC from 135,000\$/AvegYear to 20,000\$/AvegYear. The inspection of the THT pipeline is planned for July 24th, 2025, while THT tank will be inspected almost a year and a half later. The THT tank is also characterized by the highest difference between the FRTC WO. I. and the FRTC W. I., while about 65,000\$/AvegYear is the gap between the two costs for the filter. The risk target of 20,000\$/AvegYear is never reached for the pre-heating devices, therefore the lowest priority is assigned to their inspections.

4. Results and discussion

By comparing the rankings obtained by the three approaches some differences stand out. The THT tank and the THT pipeline are considered the most critical components for the method based on the HBM, moreover both the boiler and the water pipe have priority over the pressure regulation devices.

By contrast, the pre-heating apparatus is established as the least critical unit by both the QRA and the RBI. The last two techniques also highlighted the filter as the most critical component, while they rank the THT tank and the THT pipeline on inverted positions.

Even if the approaches were applied to the same plant some differences emerged due to the different sensitivities of the methodologies. Accurate probabilities of failure are used by the first method, while the severity is assessed via a semi-quantitative approach. Besides the total cost of failure is considered for the analysis. On the other side standard frequencies (which are less accurate than the previous ones) are adopted for the second technique, which provides more precise results regarding the consequences. In addition to that no cost data are considered by Safeti, indeed only the potential damages to the people and the environment are evaluated by the software. At last frequencies from API standards are exploited during the third methodology, while a semi-quantitative approach is used for assessing the consequences. Furthermore, many cost items are specified for the method based on Synergi Plant.

4.1 CRPN method sensitivity analysis

The first proposed methodology is very sensitive to variation of the adopted costs. For instance, instead of considering the total cost of failure, the cost of the component plus the cost of maintenance could be adopted. Transforming the costs into dimensionless values through the estimated pump cost of 1,000€, the ranking showed by Table 16 is obtained. The levels of occurrence and severity are given for each component by Table 3 and Table 4 respectively.

Table 16

Ranking obtained via the CRPN methodology after changing the cost data

Ranking	Component	O	S	C	CRPN
1	THT tank	4	9	3	108
2	Boiler	5	5	3	75
3	Pressure Regulator	2	9	4	72
4	Filter	4	9	2	72
5	RCS	5	6	2	60
6	THT pipelines	2	9	3	54
7	Water pipe	8	2	2	32
8	Meter	3	3	2	18
9	Pilot	1	8	2	16
10	Calculator	5	3	1	15
11	Pump	5	3	1	15
12	PTG	6	2	1	12

The THT tank is still regarded as the most critical device with a CRPN equal to 108, however the THT pipelines dropped from the second place to the sixth. The boiler climbed one position, ending up in third place. The greatest jump is registered for the pressure regulator, which passed from being the seventh most critical components to being the third most critical one.

The results are also affected by changes of the adopted severity and occurrence categories. As an example, Table 17 and Table 18 are used to assign to each component a class of occurrence and severity respectively. Accordingly, the ranking illustrated by Table 19 is found.

Table 17

New occurrence criteria ranking

Occurrence	Occurrence probability	Component
1	<1 in 30,000	Pilot
2	1 in 10,000	Pressure regulator, THT pipe, meter, Filter, THT tank
3	1 in 3000	RCS, calculator, boiler, pump, water pipe
4	1 in 2000	
5	1 in 1000	PTG

Table 18

New severity criteria ranking

Severity	Severity of effect	Component
1	No effect	
2	Minor effect	Water pipe, PTG, pump, meter, calculator
3	Moderate effect	Boiler, RCS
4	Major effect	Pilot
5	Catastrophic effect	THT tank, THT pipelines, Pressure regulator, Filter

Table 19

Ranking obtained via the CRPN method after changing the occurrence and severity criteria

Ranking	Component	Occurrence	Severity	Cost	C-RPN
1	Pressure Regulator	2	5	4	40
2	THT tank	2	5	3	30
3	THT pipelines	2	5	3	30
4	Boiler	3	3	3	27
5	Filter	2	5	2	20
6	RCS	3	3	2	18

7	Pump	3	5	1	15
8	Water pipe	3	2	2	12
9	PTG	5	2	1	10
10	Pilot	1	4	2	8
11	Meter	2	2	2	8
12	Calculator	3	2	1	6

The pressure regulator emerged as the most critical equipment, followed by the THT tank and the THT pipeline. With respect to the first ranking, the filter has acquired a relevant spot, while the RCS is deprioritised.

4.2 Safeti-QRA sensitivity analysis

The consequence analysis performed by Safeti is really accurate, however the obtained ranking is deeply influenced by the adopted standard frequencies. Changing the input frequencies causes indeed a variation of the calculated risk integral percentages on which the ranking is based. To demonstrate the last statement a FT is developed for the small leakage of each component. The FT of the small leakage for a pressure regulator is showed by Fig. 12 and Fig 13, while the considered events are listed in Table 20.

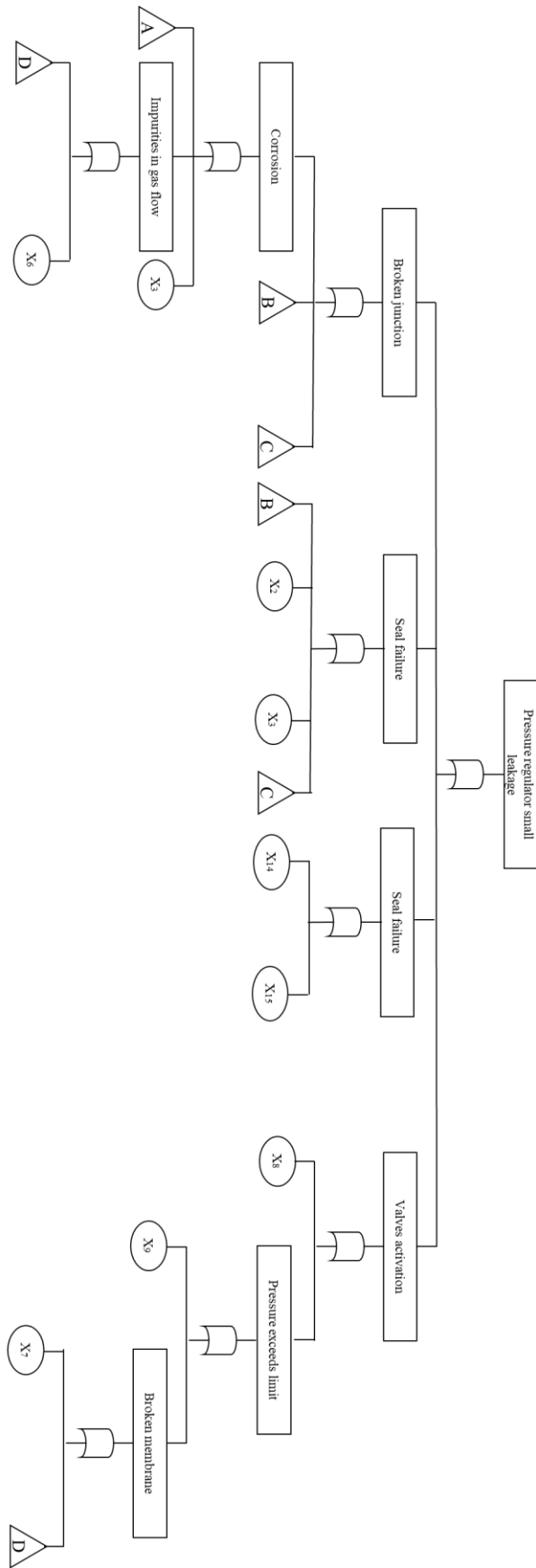

Fig. 12. Adopted FT for the small leakage of the pressure regulator

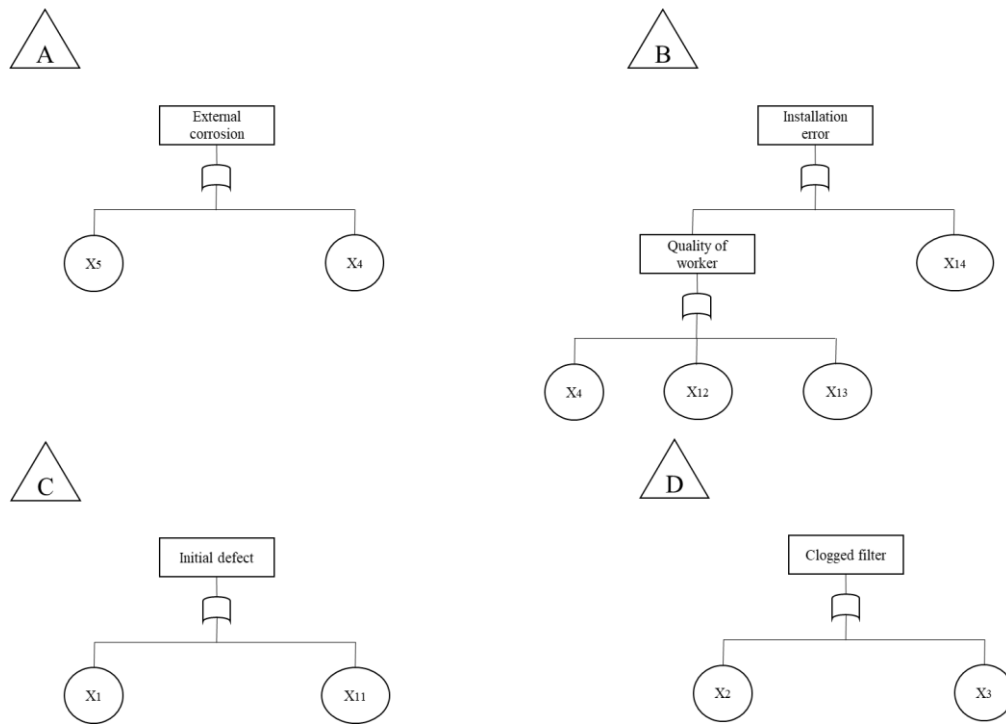

Fig. 13. Macro-events of the FT showed in Fig. 12

Table 20

Considered events for the FT of the pressure regulator small leakage

#	Event
X1	Material defect
X2	Aging
X3	Lacking or defective maintenance
X4	Intentional error during operation
X5	Failure of coating
X6	Extremely bad quality of inlet gas
X7	Wearing
X8	Bad interpretation of signal (mistake)
X9	Higher pressure of the upstream flow
X10	Improper equipment
X11	Construction defect
X12	Inadequate training
X13	Inadequate experience
X14	Blockage of pipes
X15	Poor assembling

Adopting the FTs, the probabilities found in literature [58, 59] illustrated by Table 21 and considering the results of the HBM for the seal and junction joint annual probability of failure, the small leakage

frequencies listed in Table 22 are calculated. Using the aforementioned frequencies for the QRA produces a different ranking (Table 23) compared to the previous one.

Table 21

Annual probabilities of the FT's basic events

Event	Probability (annual)
Intentional error (X4)	0.0001
Improper equipment (X10)	0.003
Inadequate training (X12)	0.0004
Inadequate experience (X13)	0.0001
Blockage of pipes (X14)	0.028
Valves activation	0.003

Table 22

New calculated frequencies via FT analysis for the small leakage of each considered component

Scenario	Frequency [event/year]
THT tank small leak	0.079
Pressure Regulator small leak	0.082
Filter small leak	0.071
THT pipeline small leak	0.064

Table 23

Ranking obtained via Safeti after changing the input frequencies

Ranking	Component	Risk integral percentage
1	Pressure Regulator	39.70
2	Filter	33.92
3	THT tank	20.14
4	THT pipeline	5.77
5	Water pipe	0
5	Pump	0
5	Boiler	0

The calculation depicted that the most critical component is the pressure regulator, with a risk integral percentage equal to 39.70. On the other side the filter has fallen from the first place to the second one, with an estimated 40 points reduction of the risk metric. Despite this the pressure reduction unit is still evaluated as the most compelling group due to its global risk integral percentage of 67.62. At last the third and fourth highest risk values are associated to the THT tank and the THT pipeline respectively.

4.3 Synergi Plant-RBI sensitivity analysis

During the presentation of the method, one risk target and one future evaluation date are adopted to produce the criticality ranking. Nevertheless, different strategies could be used to pinpoint the most critical components. For instance, considering three future evaluation dates, the trend of the FRTC WO. I. could be studied to determine the devices whose maintenance is a priority. Table 24 and Fig. 14 illustrate the results of the analysis.

Table 24

Variation of the FRTC WO. I. for different future evaluation dates

Component	07/11/2021	07/11/2026	07/11/2031
THT tank	512	17,065	295,490
THT pipeline	536	26,345	44,274
Boiler	50	4,568	7,780
Water pipe	50	4,568	7,780
Pump	50	4,568	7,780
Filter	434	39,339	66,991

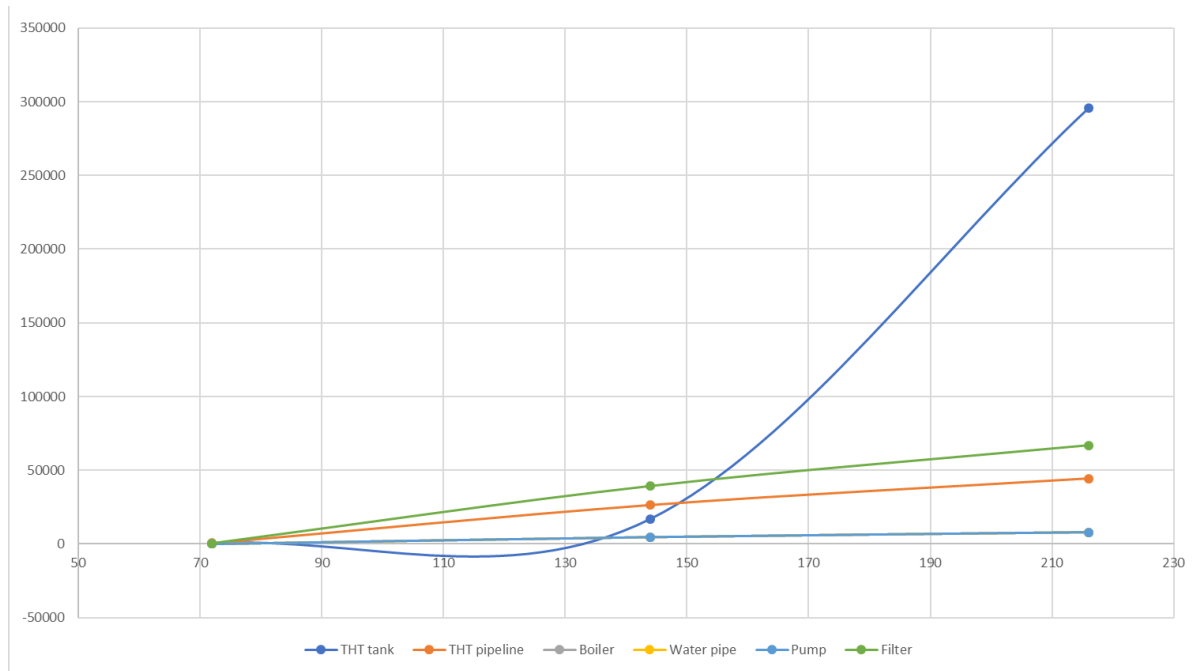

Fig. 14. Trend of the FRTC for each component (Y axis). The X axis is expressed in months

Based on the FRTC WO.I. trend the THT tank is regarded as the most critical component, indeed its risk experiences the greatest increase. Moving from the 7th November, 2026 to 7th November, 2031, its FRTC WO.I. raises from 17,065\$/AvegYear to almost 300,000\$/AvegYear. As a result, the THT tank must be monitored and inspected continuously to avoid big losses and immoderate risk. The remaining components are characterized by an increasing trend too, but their FRTC WO.I. variations are smaller. The FRTC WO. I. of the filter and the THT pipeline are similar on the 7th November, 2021, but on the 7th November, 2031 the FRTC WO.I. calculated for the filter is about 20,000\$/AvegYear higher than the value associated to the THT pipeline. At last the pre-Heating group components are the less critical ones, indeed they have the lowest FRTC WO.I. with a maximum value of about 8,000\$/AvegYear on the 7th November 2031.

Varying the risk threshold may also affect the ranking. Considering five levels of risk target, the obtained results are showed by Table 25 and Fig. 16.

Table 25

Variation of the inspection date expressed in months for different risk threshold values

Component	Risk Target [\$/AvegYear]				
	10,000	20,000	30,000	40,000	50,000
THT tank	123	132	140	144	148
THT pipeline	97	114	144	180	203
Boiler	217	405	577	1,188	1,188
Water pipe	217	405	577	1,188	1,188
Pump	217	405	577	1,188	1,188

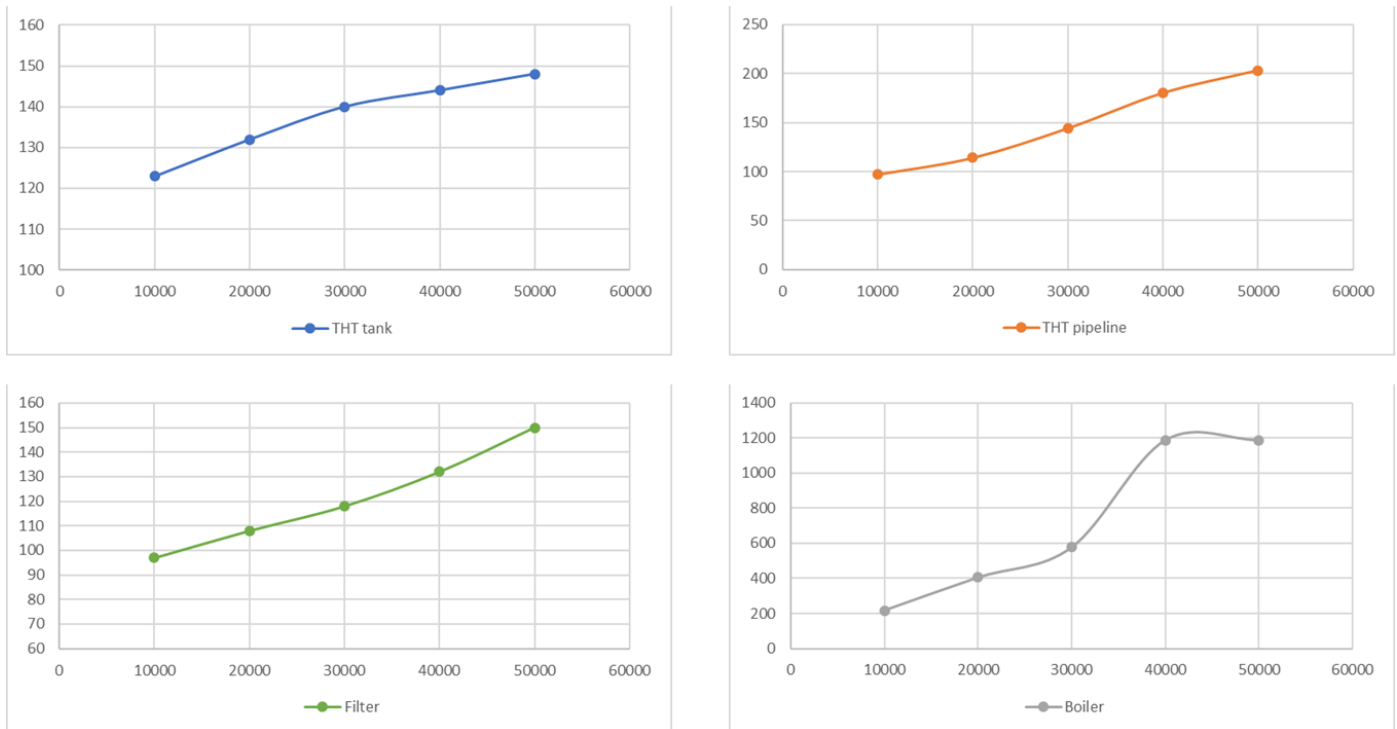

Fig. 15. Trend of the inspection date (months) for different risk threshold values (X-axis).

The pump, the boiler and the water pipe are characterized by the longest inspection interval for each category of the risk target. If the company accepts high level of risk (40,000\$/AvegYear or 50,000\$/AvegYear) the inspection of the water components is planned for January 2115, otherwise if the enterprise is highly risk adverse the inspection task is performed earlier: on the 16th October, 2050 if the threshold is set at 20,000\$/AvegYear or on the 11th February 2064 with a considered risk target of 30,000\$/AvegYear. The filter is the first component to be inspected for a risk target from 10,000\$/AvegYear to 40,000\$/AvegYear, however adopting a threshold value of 50,000\$/AvegYear gives priority to the THT tank with an inspection planned approximately two months earlier than the filter. Depending on the adopted risk target, the inspection plan is significantly different, indeed using the first value of the metric, the THT tank would be inspected 2 years later compared to the filter and the THT tank. By contrast, the THT tank inspection precedes the THT pipe inspection for a risk target of 30,000\$/AvegYear and the inspection of the filter when 50,000\$/AvegYear is adopted as maximum tolerable risk.

5. Conclusions

This work presents a comparative study of three different RBM techniques. These approaches are able to generate a criticality ranking, highlighting the most critical devices towards which

maintenance efforts should be directed. NGRMS was chosen as case of study to illustrate the three frameworks, while underlining their advantages and limitations. In the first methodology HBM was adopted to estimate the likelihood of occurrence, while a FMECA was used to evaluate the consequences arising from potential failures. After introducing the total cost of failure the CRPN is calculated for each component. For the second methodology a software named Safeti is adopted to conduct a QRA. Through the calculation of the software the devices are ranked based on their respective risk integral percentage. At last the third method consists in a RBI, exploiting a software named Synergi Plant. The C-RPN method is characterized by a weak semi-quantitative consequence analysis. Besides, the accurate approach used to calculate the failure probabilities is degraded with the discretization of the occurrence. By contrast, the QRA via Safeti is accurate in performing consequence analysis, but it is very sensitive to variation of the input frequencies and finally the RBI plan obtained through Synergi Plant is influenced by the uncertainties of costs and company policies. The last method is therefore suggested to be applied when costs data and enterprise policies are well defined and precise. The Safeti analysis is the best way to perform RBM when accurate frequencies are available and at last the C-RPN method can be adopted for screening analysis because of its sensitivity to user choices. Further development could exploit the HBM as long with precursor data to calculate precise probabilities of the reference scenarios, which could then be used to perform the QRA via Safeti.

6. References

1. Ma, L., L. Cheng, and M. Li, *Quantitative risk analysis of urban natural gas pipeline networks using geographical information systems*. Journal of Loss Prevention in the Process Industries, 2013. **26**(6): p. 1183-1192.
2. Jo, Y.-D. and D.A. Crowl, *Individual risk analysis of high-pressure natural gas pipelines*. Journal of Loss Prevention in the Process Industries, 2008. **21**(6): p. 589-595.
3. Lu, L., et al., *A comprehensive risk evaluation method for natural gas pipelines by combining a risk matrix with a bow-tie model*. Journal of Natural Gas Science and Engineering, 2015. **25**: p. 124-133.
4. Peng, X.-y., et al., *Overall reliability analysis on oil/gas pipeline under typical third-party actions based on fragility theory*. Journal of Natural Gas Science and Engineering, 2016. **34**: p. 993-1003.
5. Wang, Y., et al., *Development of a risk-based maintenance strategy using FMEA for a continuous catalytic reforming plant*. Journal of Loss Prevention in the Process Industries, 2012. **25**(6): p. 958-965.

6. Alsyouf, I., *The role of maintenance in improving companies' productivity and profitability*. International Journal of production economics, 2007. **105**(1): p. 70-78.
7. Bashiri, M., H. Badri, and T.H. Hejazi, *Selecting optimum maintenance strategy by fuzzy interactive linear assignment method*. Applied Mathematical Modelling, 2011. **35**(1): p. 152-164.
8. Zou, G., et al., *Probabilistic investigations into the value of information: A comparison of condition-based and time-based maintenance strategies*. Ocean Engineering, 2019. **188**: p. 106181.
9. Fauriat, W. and E. Zio, *Optimization of an aperiodic sequential inspection and condition-based maintenance policy driven by value of information*. Reliability Engineering & System Safety, 2020. **204**: p. 107133.
10. Duan, C., Z. Li, and F. Liu, *Condition-based maintenance for ship pumps subject to competing risks under stochastic maintenance quality*. Ocean Engineering, 2020. **218**: p. 108180.
11. Kang, J., Z. Wang, and C.G. Soares, *Condition-based maintenance for offshore wind turbines based on support vector machine*. Energies, 2020. **13**(14): p. 3518.
12. Liang, Z., et al., *Condition-based maintenance for long-life assets with exposure to operational and environmental risks*. International Journal of Production Economics, 2020. **221**: p. 107482.
13. Mahmoodzadeh, Z., et al., *Condition-Based Maintenance with Reinforcement Learning for Dry Gas Pipeline Subject to Internal Corrosion*. Sensors, 2020. **20**(19): p. 5708.
14. Ganesh, S., et al., *Design of condition-based maintenance framework for process operations management in pharmaceutical continuous manufacturing*. International Journal of Pharmaceutics, 2020. **587**: p. 119621.
15. Cullum, J., et al., *Risk-Based Maintenance Scheduling with application to naval vessels and ships*. Ocean Engineering, 2018. **148**: p. 476-485.
16. BahooToroody, A., et al., *Multi-level optimization of maintenance plan for natural gas system exposed to deterioration process*. Journal of hazardous materials, 2019. **362**: p. 412-423.
17. Abaei, M.M., et al., *A robust risk assessment methodology for safety analysis of marine structures under storm conditions*. Ocean Engineering, 2018. **156**: p. 167-178.
18. Arunraj, N. and J. Maiti, *Risk-based maintenance—Techniques and applications*. Journal of hazardous materials, 2007. **142**(3): p. 653-661.

19. Khan, F.I. and M. Haddara, *Risk-based maintenance (RBM): A new approach for process plant inspection and maintenance*. Process Safety Progress, 2004. **23**(4): p. 252-265.
20. Brown, S.J. and I. Le May, *Risk-based hazardous release protection and prevention by inspection and maintenance*. J. Pressure Vessel Technol., 2000. **122**(3): p. 362-367.
21. Brennan, F., *Risk based maintenance for offshore wind structures*. Procedia CIRP, 2013. **11**: p. 296-300.
22. Sørensen, J.D., *Framework for risk-based planning of operation and maintenance for offshore wind turbines*. Wind Energy: An International Journal for Progress and Applications in Wind Power Conversion Technology, 2009. **12**(5): p. 493-506.
23. Ambühl, S. and J.D. Sørensen, *On Different Maintenance Strategies for Casted Components of Offshore Wind Turbines*. 2017.
24. Yeter, B., Y. Garbatov, and C.G. Soares, *Risk-based maintenance planning of offshore wind turbine farms*. Reliability Engineering & System Safety, 2020: p. 107062.
25. Krishnasamy, L., F. Khan, and M. Haddara, *Development of a risk-based maintenance (RBM) strategy for a power-generating plant*. Journal of Loss Prevention in the process industries, 2005. **18**(2): p. 69-81.
26. Fujiyama, K., et al., *Risk-based inspection and maintenance systems for steam turbines*. International Journal of Pressure Vessels and Piping, 2004. **81**(10-11): p. 825-835.
27. Jaderi, F., Z.Z. Ibrahim, and M.R. Zahiri, *Criticality analysis of petrochemical assets using risk based maintenance and the fuzzy inference system*. Process Safety and Environmental Protection, 2019. **121**: p. 312-325.
28. Arunraj, N. and J. Maiti, *Risk-based maintenance policy selection using AHP and goal programming*. Safety science, 2010. **48**(2): p. 238-247.
29. Leoni, L., et al., *Developing a risk-based maintenance model for a Natural Gas Regulating and Metering Station using Bayesian Network*. Journal of Loss Prevention in the Process Industries, 2019. **57**: p. 17-24.
30. Pui, G., et al., *Risk-based maintenance of offshore managed pressure drilling (MPD) operation*. Journal of Petroleum Science and Engineering, 2017. **159**: p. 513-521.
31. Khan, F.I. and M.R. Haddara, *Risk-based maintenance of ethylene oxide production facilities*. Journal of hazardous materials, 2004. **108**(3): p. 147-159.
32. Khan, F.I. and M.M. Haddara, *Risk-based maintenance (RBM): a quantitative approach for maintenance/inspection scheduling and planning*. Journal of loss prevention in the process industries, 2003. **16**(6): p. 561-573.

33. Trucco, P., et al., *A Bayesian Belief Network modelling of organisational factors in risk analysis: A case study in maritime transportation*. Reliability Engineering & System Safety, 2008. **93**(6): p. 845-856.
34. Paltrinieri, N. and F. Khan, *Dynamic risk analysis in the chemical and petroleum industry: Evolution and interaction with parallel disciplines in the perspective of industrial application*. 2016: Butterworth-Heinemann.
35. Martins, M.R., A.M. Schleder, and E.L. Drogue, *A methodology for risk analysis based on hybrid bayesian networks: application to the regasification system of liquefied natural gas onboard a floating storage and regasification unit*. Risk analysis, 2014. **34**(12): p. 2098-2120.
36. Spiegelhalter, D., et al., *OpenBUGS user manual, version 3.0. 2*. MRC Biostatistics Unit, Cambridge, 2007.
37. Yang, M., F.I. Khan, and L. Lye, *Precursor-based hierarchical Bayesian approach for rare event frequency estimation: a case of oil spill accidents*. Process safety and environmental protection, 2013. **91**(5): p. 333-342.
38. Arzaghi, E., et al., *A hierarchical Bayesian approach to modelling fate and transport of oil released from subsea pipelines*. Process Safety and Environmental Protection, 2018. **118**: p. 307-315.
39. BahooTorood, A., et al., *Bayesian Regression Based Condition Monitoring Approach for Effective Reliability Prediction of Random Processes in Autonomous Energy Supply Operation*. Reliability Engineering & System Safety, 2020: p. 106966.
40. Mishra, M., et al., *Bayesian hierarchical model-based prognostics for lithium-ion batteries*. Reliability Engineering & System Safety, 2018. **172**: p. 25-35.
41. BahooTorood, A., et al., *On reliability challenges of repairable systems using hierarchical bayesian inference and maximum likelihood estimation*. Process Safety and Environmental Protection, 2020. **135**: p. 157-165.
42. Abaei, M.M., et al., *Dynamic reliability assessment of ship grounding using Bayesian Inference*. Ocean Engineering, 2018. **159**: p. 47-55.
43. Kumar, G. and J. Maiti, *Modeling risk based maintenance using fuzzy analytic network process*. Expert Systems with Applications, 2012. **39**(11): p. 9946-9954.
44. Kelly, D.L. and C.L. Smith, *Bayesian inference in probabilistic risk assessment—the current state of the art*. Reliability Engineering & System Safety, 2009. **94**(2): p. 628-643.
45. El-Gheriani, M., et al., *Major accident modelling using spare data*. Process Safety and Environmental Protection, 2017. **106**: p. 52-59.

46. Siu, N.O. and D.L. Kelly, *Bayesian parameter estimation in probabilistic risk assessment*. Reliability Engineering & System Safety, 1998. **62**(1-2): p. 89-116.
47. Jafari, M.J., E. Zarei, and N. Badri, *The quantitative risk assessment of a hydrogen generation unit*. international journal of hydrogen energy, 2012. **37**(24): p. 19241-19249.
48. Dziubiński, M., M. Frątczak, and A. Markowski, *Aspects of risk analysis associated with major failures of fuel pipelines*. Journal of Loss Prevention in the Process Industries, 2006. **19**(5): p. 399-408.
49. Iovinea, A., et al., *Risk Analysis of a Supercritical Fluid Extraction Plant using a Safety Software*. CHEMICAL ENGINEERING, 2020. **79**.
50. Shaba, K. and N. Cavanagh, *A software model for the assessment of the consequences of explosions in congested and confined spaces on personnel, buildings and process equipment*. Chemical Engineering Transactions, 2014. **36**: p. 535-540.
51. Ma, G., Y. Huang, and J. Li, *VCE Overpressure Prediction Using Empirical Methods*, in *Risk Analysis of Vapour Cloud Explosions for Oil and Gas Facilities*. 2019, Springer. p. 23-44.
52. Huang, Y., G. Ma, and J. Li, *Grid-based risk mapping for gas explosion accidents by using Bayesian network method*. Journal of Loss Prevention in the Process Industries, 2017. **48**: p. 223-232.
53. McKenna, B., et al. *Dispersion Model Prediction of the Jack Rabbit II Chlorine Experiments Using Drift and Phast*. in *Symposium Series*. 2016.
54. Leoni, L., et al., *On Hierarchical Bayesian based Predictive Maintenance of Autonomous Natural Gas Regulating Operations*. Process Safety and Environmental Protection, 2020.
55. Cox, A.W., F.P. Lees, and M. Ang, *Classification of hazardous locations*. 1990: IChemE.
56. Lees, F., *Lees' Loss prevention in the process industries: Hazard identification, assessment and control*. 2012: Butterworth-Heinemann.
57. Bahadori, A., *Natural gas processing: technology and engineering design*. 2014: Gulf Professional Publishing.
58. Zarei, E., et al., *Dynamic safety assessment of natural gas stations using Bayesian network*. Journal of hazardous materials, 2017. **321**: p. 830-840.
59. Philpot, R., *The Purple Book*. 2011: Biteback publishing.