



UNIVERSITÀ
DEGLI STUDI
FIRENZE

FLORE

Repository istituzionale dell'Università degli Studi di Firenze

Energy and wear optimisation of train longitudinal dynamics and of traction and braking systems

Questa è la Versione finale referata (Post print/Accepted manuscript) della seguente pubblicazione:

Original Citation:

Energy and wear optimisation of train longitudinal dynamics and of traction and braking systems / R. Conti; E. Galardi; E. Meli; D. Nocciolini; L. Pugi; A. Rindi. - In: VEHICLE SYSTEM DYNAMICS. - ISSN 0042-3114. - ELETTRONICO. - (2015), pp. 1-22. [10.1080/00423114.2014.990466]

Availability:

The webpage <https://hdl.handle.net/2158/981198> of the repository was last updated on 2021-03-29T17:49:20Z

Published version:

DOI: 10.1080/00423114.2014.990466

Terms of use:

Open Access

La pubblicazione è resa disponibile sotto le norme e i termini della licenza di deposito, secondo quanto stabilito dalla Policy per l'accesso aperto dell'Università degli Studi di Firenze (<https://www.sba.unifi.it/upload/policy-oa-2016-1.pdf>)

Publisher copyright claim:

Conformità alle politiche dell'editore / Compliance to publisher's policies

Questa versione della pubblicazione è conforme a quanto richiesto dalle politiche dell'editore in materia di copyright.

This version of the publication conforms to the publisher's copyright policies.

La data sopra indicata si riferisce all'ultimo aggiornamento della scheda del Repository FloRe - The above-mentioned date refers to the last update of the record in the Institutional Repository FloRe

(Article begins on next page)

Research Paper

Energy and Wear Optimization of Train Longitudinal Dynamics and of Traction and Braking Systems

R. Conti, E. Galardi, E. Meli, D. Nocciolini, L. Pugi, A. Rindi^{a*}

^a*Via Santa Marta 3, 50139 Firenze, Italy;*

(v3.5 released June 2008)

Traction and braking systems deeply affect longitudinal train dynamics, especially when an extensive blending phase among different pneumatic, electric and magnetic devices is required. The energy and wear optimization of longitudinal vehicle dynamics has a crucial economic impact and involves several engineering problems such as wear of braking friction components, energy efficiency, thermal load on components, level of safety in degraded or adhesion conditions (often constrained by the current regulation in force on signaling or other safety related subsystem).

In this work, an innovative integrated procedure is proposed by the authors to optimize longitudinal train dynamics and traction and braking maneuvers both in terms of energy and wear. The new approach has been applied to existing test cases and validated with experimental data.

In particular simulation results are referred to the simulation tests performed on a high speed train (AnsaldoBreda Emu V250) and on a Tram (Ansaldo Breda Sirio Tram) .

The proposed approach is based on a modular simulation platform in which the sub-models corresponding to different subsystems can be easily customized, depending on the considered application, on the availability of technical data and on the homologation process of the component. In particular, some data concerning components and their homologation process are the results of experimental activities which derives from cooperation performed with relevant industrial partners such as Trenitalia and Italcertifer.

Keywords: railway longitudinal dynamics, traction system, braking system, blending, energy optimization, energy storage

1. Introduction

The aim of this work is the description of a complete tool developed in Matlab Simulink environment for the simulation and for the optimization of the railway traction systems. In particular, the attention is focused on the energy efficiency, on the thermal loads of traction motors and subsystems and on the wear optimization of brake discs and pads. The tool is briefly called U-TOT which is the acronym of University of Florence (UNIFI, Italy)-Traction Optimizer Tool.

The development of efficient numerical models for the simulation and for the optimization of railway vehicle systems is still a research object and has an industrial interest, as stated by recent contribution available in literature which are typically focused on different aspects of the problem.

Traction and braking systems deeply affect longitudinal train dynamics, especially when an extensive blending phase among different pneumatic, electric and magnetic devices is required.

In particular the simulation of power vehicle traction systems, including motors

*Corresponding author. Email: luca.pugi@unifi.it

and power electronics is the object of recent works [1], [2] and [3]. The attention is focused especially on the following aspects:

- modularity: a modular structure is usually preferred in order to make easier the customization of the model respect to different vehicles and to traction systems;
- numerical efficiency and real time implementation: models are usually simplified and optimized for the real time implementation. This requirement is highly important mainly for two reasons: first, real time optimization is mandatory for the development of HIL applications or for model based control and diagnostic systems. The second one is that the dynamical behaviour of electric system is faster than mechanical ones. As a consequence, in order to perform complex simulations of the whole system, the numerical resources required by the models of traction subsystems have to be optimized as much as possible;
- Implementation on high level simulation tools such as Simulink.

For the optimization of traction systems in terms of efficiency, maintenance and reliability an important role is performed by the simulation of the braking plant. Indeed the dynamical behavior of the vehicle and its energetic efficiency, are heavily influenced by the way in which kinetic energy of the train is recovered or dissipated during the braking phase. Recent contributions concerning these aspects have been proposed [4], [5] and [6].

More generally, since the characteristics of the vehicle subsystems is assigned, the optimization of the mission profile in terms of reference speed and performed braking and tracking maneuvers has been recently studied in several works [7] and [8]. Considering the recent improvements in the technology of energy storage systems in terms of performances, costs and reliability, more recent works are focused on the application of this kind of technology. In [9], [10], [12] and [13], main benefits and drawbacks of different technological solutions are explored. In particular three different kind of solutions are considered:

- *stationary storage systems*: energy storage system is placed in parallel to Electrical Substations which feed the contact line;
- *on board storage systems*: accumulators are placed on vehicles;
- *mixed/hybrid systems*: both stationary and on board energy storage systems are implemented.

Further distinctions should be operated in terms of proposed energy storage devices distinguishing among batteries [14], ultra-capacitors [15] and hybrid systems [16].

Typically, the choice between different technologies is decided through an optimization of the characteristics required for the energy storage devices.

In particular, considering the manufacturing advance of lithium based batteries, most of the recent works are focused on this kind of accumulators, currently neglecting the developments of nano-tubes ultra-capacitors [17] which are still considered a promising technology but not a standard industrial product.

As stated in [18], the optimal solution is strictly dependent from the considered application, in which a kinematic study of typical mission profiles of commuters and high speed trains is used to investigate feasibility and benefits associated to the combined use of regenerative braking and vehicle hybridization (on board energy storage devices).

In particular, energy recovery in the braking phase and the use of energy storage systems are very attractive for urban transport systems, metros and light railways since typical mission profiles involve low traveling speed and frequent accelerations and decelerations. As a consequence, accumulators with a relative low storage ca-

capacity should be frequently used to smooth power absorption peak associated to traction-acceleration phases and recovered energy produced by regenerative braking.

For this reason, systematic studies, such as the one proposed by [19], clearly indicate that the application of energy storage systems to urban transport system should lead to significant energy savings with lower costs respect to the construction of reversible substations. In addition, high traffic densities associated to urban transport system often assure a fast recover of the investment especially for fixed installations.

Also in [20] simulates and analyzes similar solutions in which line voltage is sustained during transients using double layer capacitors.

On the other hand, the application of on board energy storage technologies seems to be more convenient mainly in two cases:

- *discontinuous availability of electric power*: in some cases the distribution of electric power through the overhead line should be discontinuous or absent; in this case, on board energy storage systems should be quite useful to assure reliability of the electric power and autonomy of the vehicle.
- *hybridization of locomotives*: recent studies pointed their attention on the hybridization of locomotives for large freight wagons [21], as a possible option to reduce fuel consumption and to provide a better overall fuel economy.

However, most of the cited studies focused their attention on energy efficiency neglecting other complementary aspects for the optimization of traction systems which are the wear, mainly of the braking components, and the thermal behavior of both braking and traction equipments (representing an important constraint for both design and reliability of the whole system).

Another important aspect to be considered, is the possibility of dynamically redefine the mission profile in terms of traveling speed and acceleration, during the simulation and optimization process.

As confirmed by the state of art analysis, between the various research papers currently available in literature, the level of complexity and the general layout of the models implemented for the mutual optimization of traction systems respect to mission profiles are highly sensitive to the aims of the proposed simulation scenario, ranging from more general system and infrastructure optimizations to the verifications of single detailed subsystems.

For this reason, the authors propose a modular approach: the whole simulation model is designed as a highly customizable library of interchangeable submodels to meet the requirements of different applications.

Finally in order to perform this kind of simulations there is often the need of collecting large amount of data concerning the behavior of different components, an activity which usually is quite time consuming and involves a quite big interdisciplinary know-how. Consequently a considerable effort is performed to optimize the way in which some components are modelled and represented (to exploit the most possible data and technical information). The experimental data are usually available as result of the homologation process of railway components for the interoperability and safety assessments.

The work is organized as follows:

- in the chapter 2, the general system architecture and the available models are represented;
- in the chapter 3, the simulations of the Ansaldo Breda EMU V250 Traction and Braking Systems are explained. In this part it's modelled the behaviour of an

existing High Speed Train in order to preliminary validate some fundamental subsystems describing the longitudinal dynamics of the train and some complementary modules such as the virtual driver system;

- in the chapter 4, the combined optimization of energy recovery and the regenerative braking system for a tramway system are presented. A second test case in which the same tool is used to simulate a light tramways and to briefly introduce the additional tools and methodologies that have been introduced for the simulation and the optimization of energy storage systems.

2. General System Architecture and Available models

In figure 1 the current layout of UTOT (UNIFI Traction Optimization Tool) is shown: each simulated subsystem corresponds to a Matlab-Simulink Sub-Model which can be added or removed from the model. Each simulation submodel is implemented as an Atomic Subsystem (see Matlab-Simulink tech.doc. [22]) so it's possible to solve each subsystem with different integration frequencies (adopting a multi-task solver). Also each subsystem is able to load independently it's main input parameter from separated excel or text input files. As a consequence, since specifications concerning data exchanged between each subsystem are defined it's possible to define different customized models of each subsystem, corresponding to different applications or simply to different level of implementation detail. Also, if a particular set of result it's not required, as example calculation of wear of brake pads and discs, the corresponding simulation sub-model can be removed and substituted by a dummy one which don't performed any further calculation saving computational resources and time. Also a multi-task implementation is the most suitable solution also for real-time implementation over a multi-processor system such as a DSPACE one for which authors have a specific previous experience.

In table ROBERTO AGGIUNGILA it's visible a brief list of the submodels with the corresponding input-output specifications.

The following additional tools complete the model:

- Mission Designer: a tool for the design of mission profiles including, line design, altimetry profile, intermediate stations, speed limitations introduced by the signalling system, and other mission targets or constraints;
- Virtual Driver: a tool able to recreate a near to realistic sequence of manoeuvres according the simulate state of the line, and of the simulated running condition of the train. The model should be used to simulate a virtual driver following different operating strategy which should be constrained by speed limitations and interventions curve of on board ATP, ATC (Automatic Train Protection and Auto-matic Train Control) systems. The system could be forced to a customizable logic of maneuvering which can simulate also unmanned on board systems such as ATO (Automatic Train Operation).
- Mission-Vehicle Optimizer: it is an automatic iterative procedure for the optimization of mission or vehicle parameters with respect to customizable target functions such as energetic efficiency, thermal behaviour of critical components, different driving strategies corresponding for instance to different blending of braking (electric and/or pneumatic) and/or to constraints arising from signalling system. Also a weighted target function considering a mix of different aspect to be optimized can be defined. Since an optimization procedure performed using an iterative approach can be computationally expensive, parallel computing and efficient code have been specifically designed for the application. The used algorithms are derived directly from the routines available in Matlab Optimization

Toolbox for constrained problems [23], [24]. As further option the optimizer could be also used to perform Montecarlo simulations of scenarios in which some parameters are randomly perturbed in order to assess the sensitivity or robustness of the system.

Parts of the developed code could be used for the design of model based controllers and prognostic tools, due to the modular structure of the code and to the possibility of compiling its modules for different kinds of C or C++ targets. For instance compiled sub-models of the proposed tool could be integrated in distributed prognostic tools such as the one proposed by Huanhuan [25] in which the protected system can be managed with respect to a virtual performance calculated by a simplified model running in real time.

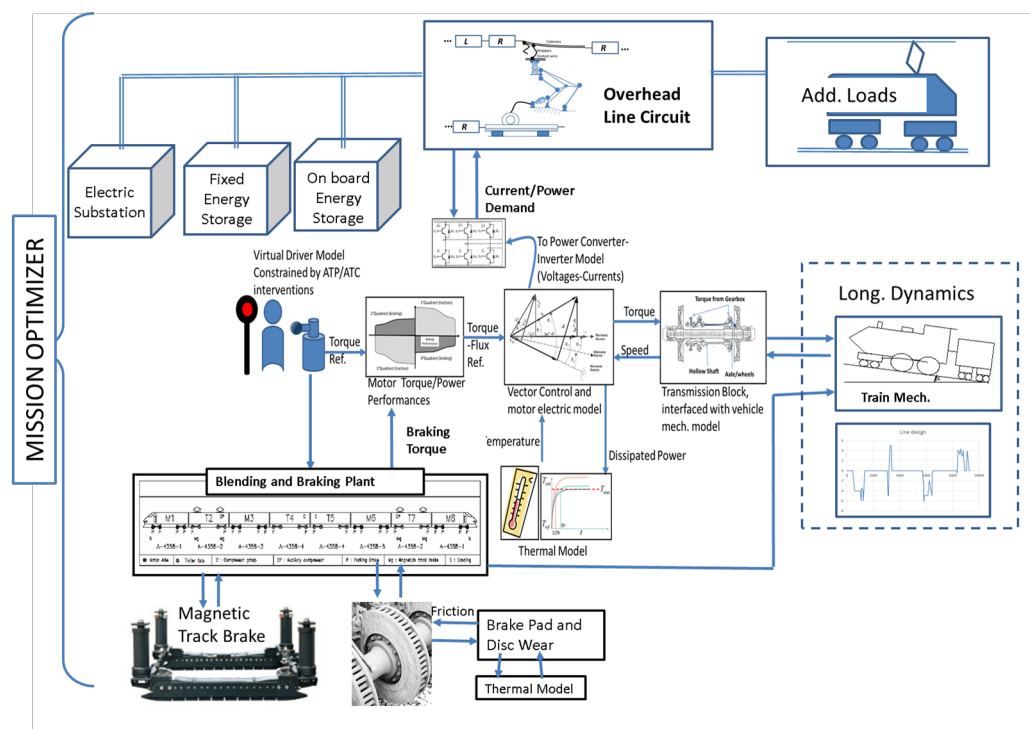

Figure 1. UNIFI Traction Optimization Tool, General Structure and Main Submodels.

Roberto mi crei una tabella dei modelli con colonne input ed output nome modello, principali funzionalit implementate

3. Simulation of the Ansaldo Breda EMU V250 Traction and Braking Systems

In order to make more clear use and functionality of the proposed model two different benchmark test case are proposed.

The first one is referred to the simulation of an high speed train the Ansaldo Breda EMU V250. Despite to the unlucky commercial history of the Fyra project [27] [28] which was mainly related to reliability troubles with snowy weather, EMU V250 represent a good benchmark for UTOT mainly for two reasons:

- Layout of the distributed traction and braking system is quite similar to the ones adopted by new high speed systems , such as, for example the new Bombardier

Zefiro V300 (operating in Italy as ETR1000) and the Zefiro V380 (operating on Chinese High Speed Lines).

- lots of experimental data were available from the prolonged experimental activities to which the train was subjected in order to be fully compliant with TSI interoperability standards. Experimental Data were quite useful to perform a preliminary validation of the model.

Considering the features of the simulated train and aim of the simulation, the modeling of some subsystems was deliberately simplified. In particular all the part corresponding to the simulation of the overhead line and its interaction with the vehicle was deliberately simplified since the line is approximated as an ideal voltage source. Also the model of brake disc and pads is simplified neglecting the wear and disc temperature calculation.

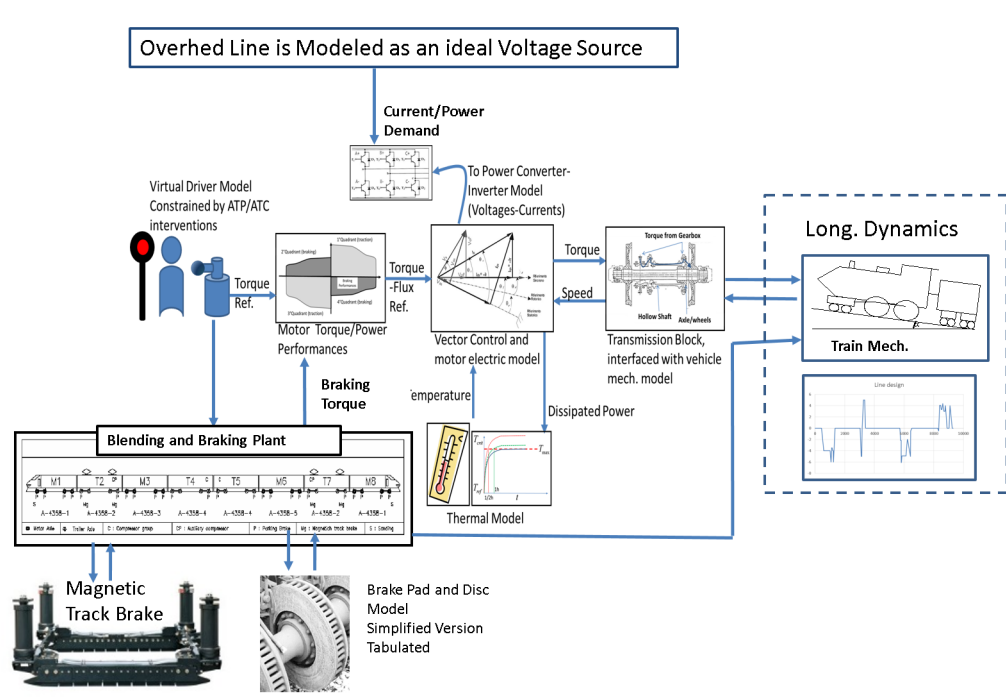

Figure 2. Simplified Configuration Adopted for the Simulation of AnsaldoBreda EMU V250

3.1. Mechanical Model

The mechanical behaviour of the vehicle is simulated according a quite efficient mono-dimensional model of the train which has been developed in previous research activities and described by equation (1):

$$F_t + F_p + F_c + F_a + F_i = 0, \quad (1)$$

where the following symbols have been adopted:

- $F_t = \sum_i^n F_{ti}$ is the sum of longitudinal traction efforts on motorized wheels - axles of the train;
- $F_p = -mg \sin \alpha \approx m_g g i$ Gravitational contribution due to slope;
- $F_c = -m g i_c$ Lumped contribution to resistances due to curves and line design;

- $F_i = -m_i \ddot{x}$ Inertial term;
- $F_a = -m_g F_{am} = -m_g (av^2 + bv + c)$.

In particular in order to consider degraded adhesion condition, longitudinal efforts applied to the wheels are saturated to a value that depends on the available adhesion simulated on the line.

For the pneumatic braking system a simplified model is adopted: a static gain G_b considering the scaling factor between the driver command and corresponding braking performance is introduced. Delays and more generally the dynamical behavior of the pneumatic braking system is simulated using a non-linear first order filter (2), whose time constant τ is variable in order to reproduce different dynamical behavior corresponding to different operating condition (service or emergency braking, release, WSP interventions etc.), which have been developed in a previous study relative to a complete and accurate model of pneumatic brake plant [29],[6],[3].

$$F_b = \frac{G_b}{\tau s + 1} \quad (2)$$

Since a trend of modern metro and railway system is the maximization of electric braking respect to the pneumatic one, also the blending of the two kind of braking system is modeled considering a mutual dependency of pneumatic and electric effort, which in the more general condition can be modeled as a function of speed, load of the vehicles, kind of braking maneuver (service, emergency) and finally plant failures and degraded conditions.

3.2. Modular Model of On Board Traction System

In order to build up a parametric model of the traction system the reference models described in figures 3 and 4 for current collection system are assumed. The electric model aims at evaluating efficiency, thermal behavior, and the main mechanical outputs (torque, accelerations), so all the proposed models of the electric and electro-mechanical components are implemented in terms of mean values, neglecting high frequency transients associated for example to switching of power electronic devices. Losses due to harmonics are introduced only in terms of tabulated values as a function of frequency, extracted from experimental data or extrapolated from dedicated models of the considered power electronic systems.

The modular approach is based on the concept to describe several components of the traction system with polynomial approximations directly provided by AnsaldoBreda. These formulations are obtained through experimental tests and model the electrical components evaluating the power losses and the power transmitted. The electrical models aim to reproduce the main mechanical outputs (torque, accelerations) and the thermal behavior. The electrical behavior is only simulated in the steady state (through the polynomial approximations), neglecting high frequency transients. Losses due to harmonics are introduced only in terms of tabulated values as a function of frequency.

In particular the following parametric components are modeled:

- motors;
- drive System: including inverters, filters and rectifiers.

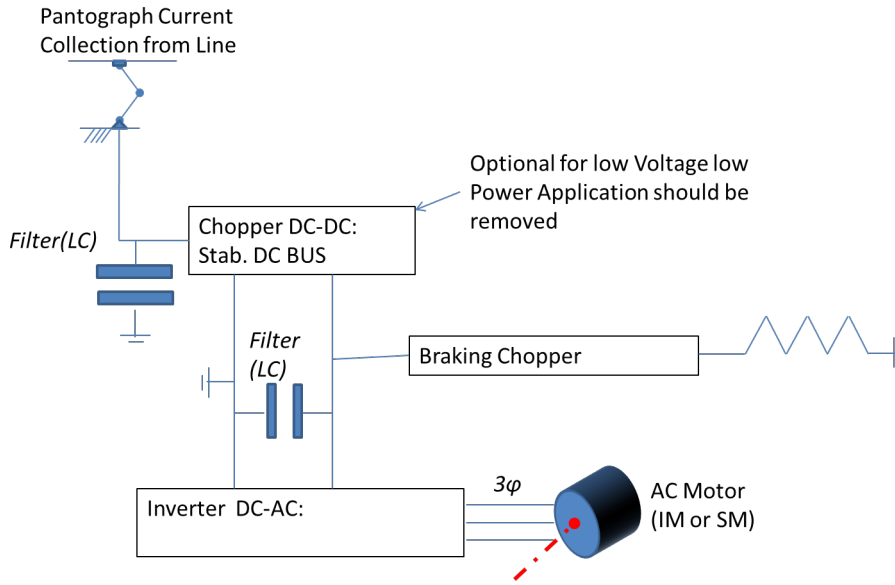

Figure 3. Simplified scheme adopted for electric traction system operating on DC lines

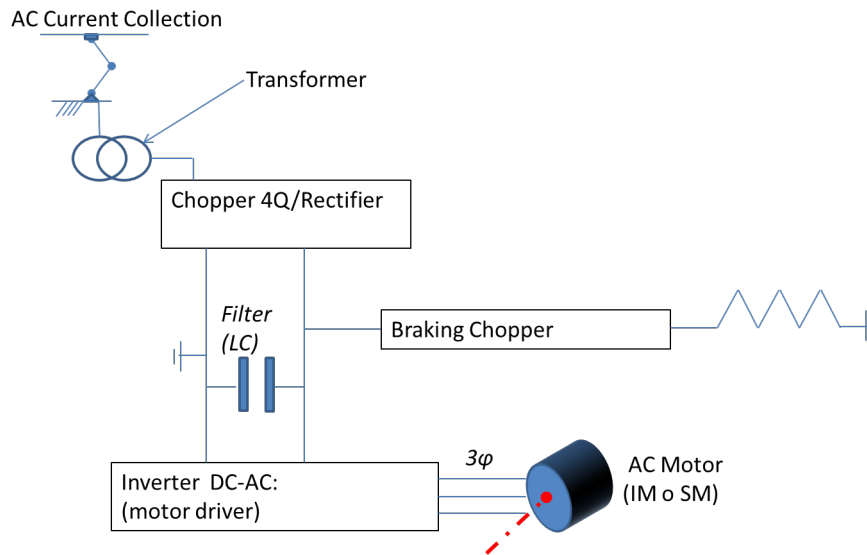

Figure 4. Simplified scheme adopted for electric traction systems operating on AC lines

3.2.1. Motors

From an electrical point of view, squirrel induction machine motors are modeled according the approach usually used for simulation and design of vector control systems [30]. Introducing slight modifications (including mutual induced fluxes between windings of the two stars), also double star squirrel cage motors should be modelled, since they are sometimes used in locomotives as the Italian E464 [31]. The electrical response of the stator and the rotor winding circuits (referred to the rotor frame) of the asynchronous motor are described by (3).

$$\begin{bmatrix} v_{qs} \\ v_{ds} \\ v_{qr} \\ v_{dr} \end{bmatrix} = \begin{bmatrix} R_s + \frac{d}{dt}L_s & 0 & \frac{d}{dt}L_m & 0 \\ 0 & R_s + \frac{d}{dt}L_s & 0 & \frac{d}{dt}L_m \\ \frac{d}{dt}L_m & -L_m\dot{\theta} & R_r + \frac{d}{dt}L_r & -L_m\dot{\theta} \\ L_m\dot{\theta} & \frac{d}{dt}L_r & L_m\dot{\theta} & R_r + \frac{d}{dt}L_r \end{bmatrix} \cdot \begin{bmatrix} i_{qs} \\ i_{ds} \\ i_{qr} \\ i_{dr} \end{bmatrix}, \quad (3)$$

where v_{qs} , v_{ds} are the stator winding voltages on the fictitious stator, v_{qr} , v_{dr} are the rotor winding voltages, L_s , L_r are respectively the equivalent stator and the rotor inductances, R_r , R_s are the equivalent rotor and stator resistances, i_{qs} , i_{ds} , i_{qr} , i_{dr} are the stator and the rotor currents referred to the $d-q$ frame, L_m is the magnetizing inductance of the stator and $\dot{\theta}$ is the time derivative of the rotor angle θ .

The whole architecture of the electrical motor model is described in figure 5.

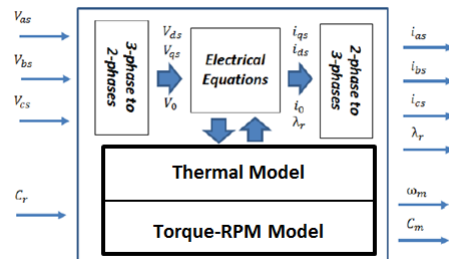

Figure 5. Electrical Motor Model, interactions between mechanical, electrical and thermal submodels

As said before, the mechanical speed of the motor is used to calculate the torque. Starting from the torque applied to the wheel-sets and, considering pure rolling condition and equivalent transmission ratio, the longitudinal traction efforts are provided to the dynamical model of the vehicle.

Motor operating conditions in terms of applied voltages and currents are calculated considering a simplified scheme of vector controller: in particular it is considered the F.O.C. (Field Oriented Control) scheme in which direct and quadrature components of stator currents respect to a synchronous reference are controlled in order to control both torque and magnetization of the motor as described in [30]. In this work an indirect F.O.C. controller is assumed for asynchronous machines. Torque and flux references (in case of flux weakening) are calculated considering driver maneuver and assigned performances of the vehicle both for traction and electric braking. The dissipated power calculated through the electrical model of the machine (including magnetization and harmonic losses) is used to calculate component efficiency; in addition also the thermal power dissipated in the motor is evaluated (according to the simplified thermal model described by equation (4)). The temperature value is then used to modify the corresponding impedance of motor circuits.

$$(T_{motor} - T_{ambient}) = \frac{W_d/B_{cool}}{\tau_{therm}s + 1}, \quad (4)$$

where the following symbols have been adopted:

- $\tau_{therm} = \frac{C_{therm}}{B_{cool}}$ is the time constant associated to the thermal transient of the component;
- T_{motor} , $T_{ambient}$ are the temperatures of motor and ambient;
- W_d is the dissipated power;
- B_{cool} , C_{therm} are the thermal exchange coefficient and capacity.

3.2.2. Inverter, filters and chopper-rectifiers

Motors are fed by inverters. Efficiency and consequently the power dissipated by the inverter are tabulated as a function of frequency, currents, and corresponding

switching/operating mode. The electrical models of the inverter, filter and chopper are based on the polynomial approximations supplied by the train maker. A simplified thermal model similar to the one described in (4) is used to calculate a reference temperature of the components.

Also filters, which are often introduced in the drive system to improve performances in terms of current harmonics, are modeled: losses due the impedance of inductive and capacitive filters (C and LC filters) are modeled considering also the dissipative effects introduced by bleeder resistances of capacitors. Also in this case a reference temperature of the component can be optionally calculated using the first order filter described in (2).

Finally voltage of vehicle DC bus should be fed and stabilized using one, two or even more multi-phase choppers working as 4Q choppers and/or rectifiers. Chopper sub-model is quite simple, since they have to allow an easy customization of the model, in order to make possible the simulation of different traction schemes, including for instance more chopper groups in parallel or series (multiphase or multilevel systems).

In this way despite the simplicity of the adopted model, it is possible to simulate a wide range of traditional and conventional traction schemes, for example those described in [15], [16] or even innovative or uncommon examples as the one described in [17].

On vehicles operating on AC lines, a transformer is usually installed, as shown in the simplified scheme of figure (??). From a thermal point of view this may be a quite critical component, since wrong or excessive optimizations aimed at reducing weight and dimensions may lead to an under-sized design of the system, which has to be typically liquid cooled. For this reason the calculation of the power dissipated on this component is relatively more detailed with respect to other components, and it takes into account not only the resistive losses on primary, secondary and auxiliary windings but also of the pumps power dissipated in the cooling circuit. More generally losses inside static and power converters are usually modeled considering polynomial relationship respect to current modulus I (rms value) and frequency ω (almost first harmonic) as example as the one described in (5).

$$W_d = a_0 + a_I I + a_{I2} I^2 + a_{\omega I} I \omega, \quad (5)$$

where the following symbols have been adopted:

- W_d is the power loss;
- a_0 , a_I , a_{I2} , $a_{\omega I}$ are the symbols adopted to identify the coefficient of the polynomial relationship;
- I and ω are the symbols to generically describe the current rms value and its frequency.

For traction inverters, as example, current is also proportional to motor torque and to the vehicle traction effort while the frequency is proportional to vehicle speed as a consequence the relation used in this work should be quite similar to the one proposed in [10].

3.2.3. Mission Profile and Automatic Driver

In most of the tools proposed in literature kinematics of the train is not constrained during the simulation but its controlled by a regulator called virtual-driver. Virtual driver operate as an ATO/ATC (acronyms of Automatic Train Operation/Control) which regulate traction and braking maneuvers in order to re-

spect speed and position constraints imposed by line design, signaling and mission timetable including position and durations of stops at stations.

Since the proposed model has to be used to reciprocally optimize traction systems, blending of the braking plant and mission speed profiles, the implemented ATO has to be quite robust respect to the variability of important variables during the optimization process which should negatively affect his performances both in terms of stability and precision. It should be also noticed that a chattering of the ATO control should produce an unrealistic behavior of the system in terms of efficiency, performances and loads to which are subjected the simulated systems.

For this reason the maneuvering of the train is controlled by a virtual ATO or driver system which tries to emulate the stability and the smooth control of an expert human driver. As visible in the scheme of figure 6, the regulator is composed by two part:

- model based controller: speed limitations imposed by the signaling systems is treated as a vector of discrete constant values \bar{V}_{lim} which are defined respect to a discrete vector of position over line \bar{x}_{lim} to which is associated a change of the value of the max allowed speed. The toothed speed profile associated to vectors \bar{V}_{lim} and \bar{x}_{lim} is filtered in order to generate a continuous speed reference $V_{ref}(x)$. Filtering is managed in the following way:
 - maximum positive acceleration of the train a_{max} is imposed; calculation of a_{max} take count of the maximum performances of the traction system including also the foreseen contribution of tabulated motion resistances such as line slope (gi);
 - also the deceleration of the train during the braking phase is constrained to follow a deceleration profile d_{max} . d_{max} is calculated according nominal braking performances of the train;
 - a more conservative mission profiles can be easily obtained by shaping the saturated acceleration and deceleration profiles a_{max} and d_{max} .

Once a continuous reference speed profile V_{ref} is generated the corresponding maneuvers in terms of traction and braking demands are calculated considering a simplified model of the train in which most of the non linear phenomena associated to the simulation of traction and braking subsystems are approximated considering nominal linearized conditions. Calculated traction and braking maneuvers are applied to the complete model of the train; an example of the calculation of the speed reference $V_{ref}(x)$ from V_{lim} are shown in figure 7.

- speed feedback controller: traction and braking maneuvers calculated by the model based controller have to be corrected since the full model of the train simulates many non linear phenomena that are not considered by the model based controller. For this reason the speed of the simulated train is also controlled by a speed regulator which slightly adjust the simulated traction and braking maneuvers in order to follow the continuous reference speed $V_{ref}(x)$. Speed feedback controller is a simple PI (Proportional Integral regulator) one. In order to avoid excessive chattering the controller gains should be gain scheduled respect to the speed error.

3.3. Preliminary Validation Results: AB EMU V250 running on Amsterdam Bruxelles line

Main mechanical features of the simulated train AB EMU V250 are shown in table 1.

Since some experimental data taken from runs along the line from Amsterdam and

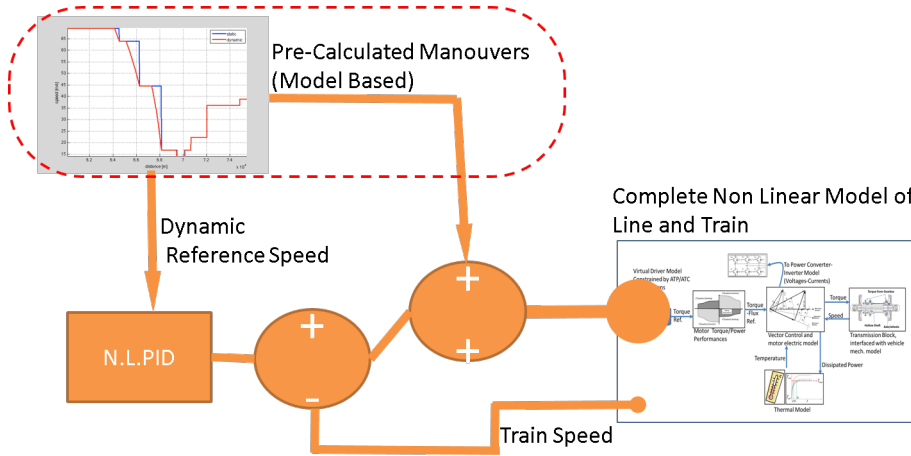

Figure 6. Virtual Driver/ATO, Simplified Scheme.

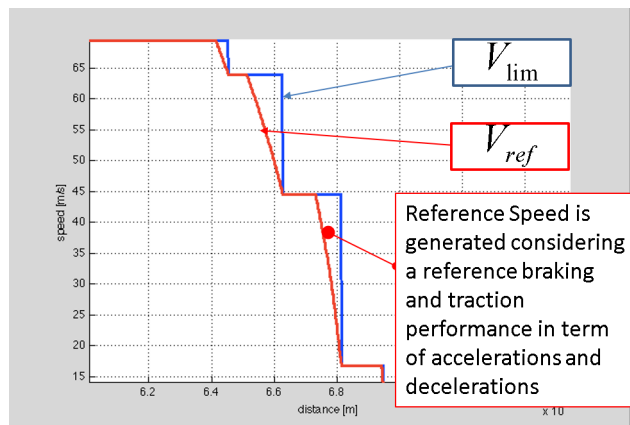

Figure 7. example of calculation of V_{ref} from V_{lim} discrete values.

Bruxelles were available authors performed some preliminary validation activities. In particular in figure 8 are reproduced some results concerning the comparison between the simulated speed of the train during a 200 km run and the corresponding data. As clearly visible in the figure there is a very good fit of the model in terms of speed profiles, so it should be easily argued that the virtual driver model perform quite accurately its work.

Table 1. tabella dati EMUV250 ROberto piazzali te for FSRQs and BL Lacs.

Class ^a	γ_1	γ_2^b	$\langle \gamma \rangle$	G	f	θ_c
BL Lacs	5	36	7	-4.0	1.0×10^{-2}	10°
FSRQs	5	40	11	-2.3	0.5×10^{-2}	14°

^aThis is not as accurate, owing to numerical error.

^bAn example table footnote to show the text turning over when a long footnote is inserted.

Some other results concerning the models used for power electronics and motors are shown in figure 9: in particular the figure shows the power absorbed for each motor, during the simulated mission respect to the corresponding validation data. Also in this case there is a very good agreement which implies also a good modelling of motors and power electronics. More generally, some results concerning relative errors in terms of speed, electric power and pneumatic efforts of the brake which are generally quite low.

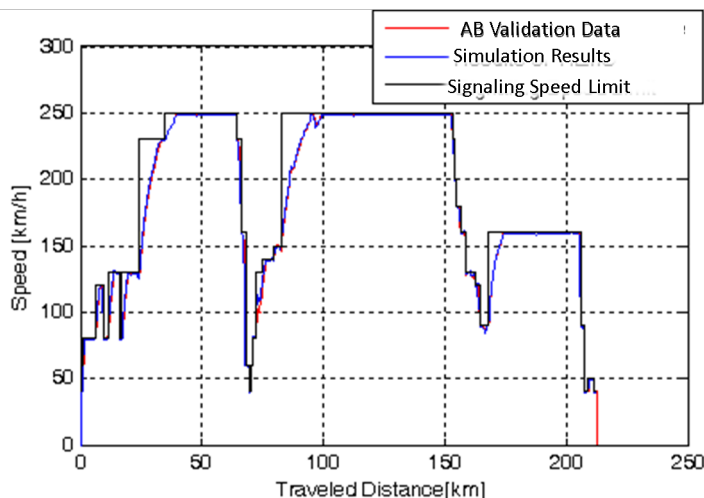

Figure 8. comparison between simulated speed profile and reference data.

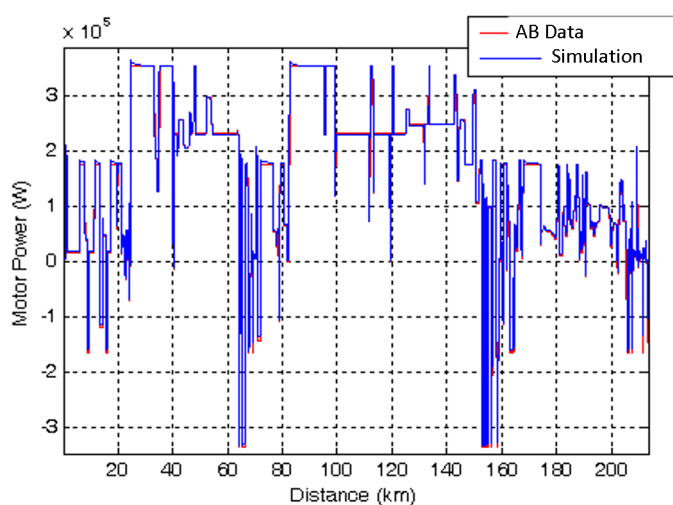

Figure 9. Electric Power absorbed by each traction motor during the simulation (including losses introduced by inverter and traction system).

Variable	Corresponding mean error%
Speed	Less than 0.5%
Collected Power	Less than 0.5%
Power to motors	Less than 0.4%
Electric Traction and braking effort	about 1%
Pneumatic Braking Effort	about 1%

Figure 10. Tabella risultati dinamica longitudinale.

In particular in order to improve the fitting of results in terms of braking distances authors have to improve the modeling of mainly two aspects [6]:

- the blending of electric and pneumatic braking: as visible in figure 11, electric braking torque is calculated as a tabulated function of the traveling speed and the pneumatic effort is automatically adjusted in order to obtain the desired braking performance;
- the friction factor of brake pad has to be tabulated as a function of train speed and loading conditions as visible in figure 12.

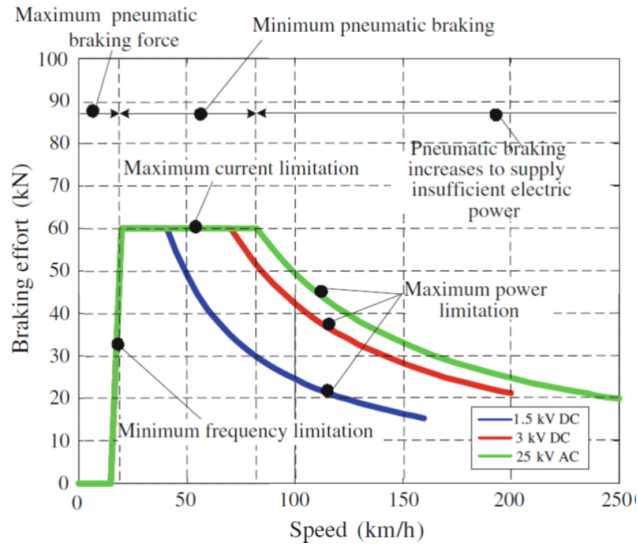

Figure 11. Blending, traction performances and blending of the pneumatic braking.

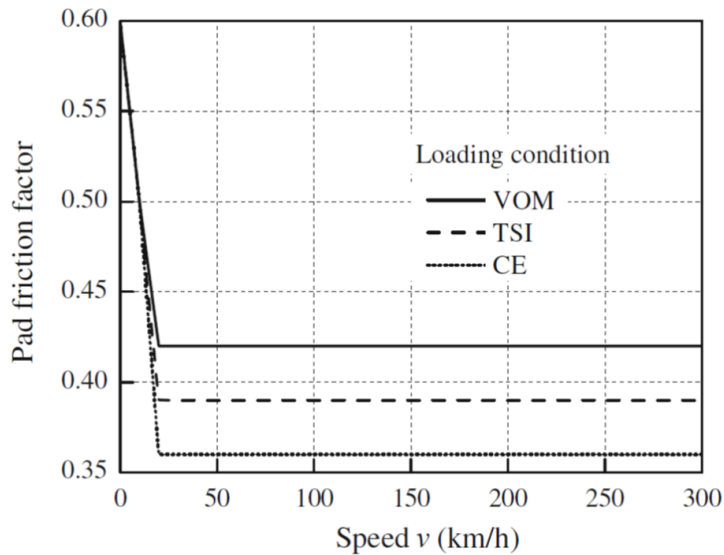

Figure 12. Tabulated Friction Factor of Pads as a function of Speed and Train Loading Condition as specified by TSI regulation in force

The approach proposed for the simulation of the pads variable friction factor and more generally the braking performances of the train was successfully evaluated by comparing the relative error in terms of braking distances between simulation results and a population of about 60 braking performed by the train with different starting speed, loading and operating conditions.

In figure 13 some results are shown: the graph show the statistical distribution of relative errors in terms of braking distances between simulation results and experimental data. The maximum recorded error was about 5.5% and for more than the half of the test populations errors were far beyond 2%, which should be considered a very good results considering the uncertainties to which are subjected experimental tests.

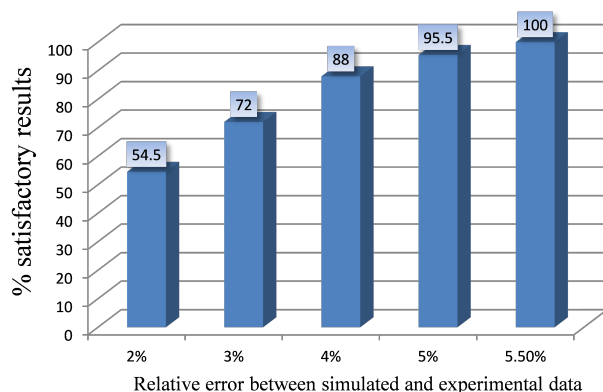

Figure 13. Cumulative Statistical distribution of relative errors in terms of braking distances between simulation results and experimental data.

4. Application of an Energy Storage System to a Tramway: the Sirio Benchmark

As briefly described in the previous sections, a preliminary validation of the main modules used for the simulation of the train with its subsystem has been preliminary performed considering as benchmark the AnsaldoBreda EMU V250. In order to further verify the possibility of using the model for the simulation, a second group of test was performed considering a Tramway (Sirio) also produced by AnsaldoBreda.

Sirio Tramway whose main data are visible in table was chosen as benchmark since there were available some validation data both from previous research activities with AnsaldoBreda, concerning the tramway of Besancon (France), and from the literature, in particular from [10],[32],[33] whose works were mainly referred to the simulation of the Sirio Tramway of Bergamo (Italy).

Main Features of the Sirio Tram are described in table ?? and in figure 14.

The corresponding scheme of the traction system of the tramway correspond to the one described in figure 3 .

<i>Main Tram Feature:</i>	
<i>Mass(Tare – VOM)</i>	42[t]
<i>Mass(AdditionalLoadMass)</i>	17[t]
<i>MaxSpeed</i>	70[km/h]
<i>MaxLong.Effort</i>	75[kN]
<i>wheelset</i>	$B_0 - 2 - B_0$

Table 2. Main Features of the Simulated Sirio Tram.

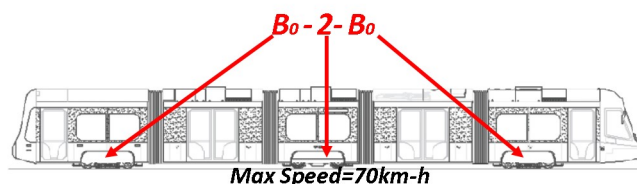

Figure 14. Wheelset of the Simulated Tram Sirio.

In order to verify model performances in this work it is considered a reference speed profile visible in figure 15 with a length of about 8000m.

For the overhead line is supposed an equivalent copper section of wires of about 100mm^2 whose data were available from literature [34].

In this preliminary work is considered a simplified case in which only one tram is traveling along the line.

4.1. Test Case Line

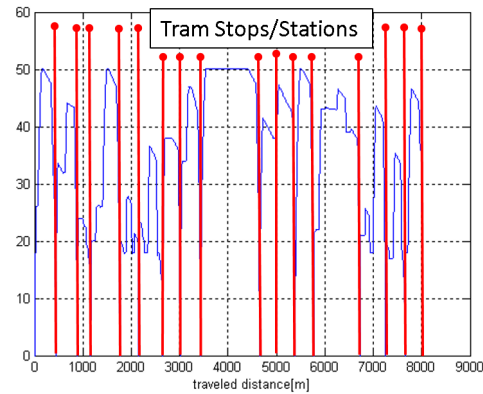

Figure 15. Besancon Tramway, simulated speed profile.

Three different configurations considering the applications of different energy storage technologies are considered:

- nominal configuration: the line section is fed by two power stations. The stations are supposed to be composed by a transformer and a rectifier, so are modeled as a voltage source with a diode and an equivalent impedance in series. The modeled power stations cannot support any regenerative braking of the tram, as a consequence, in this configuration the simulated tram can perform only dissipative and or pneumatic braking;
- configuration with stationary energy storage: in this case some energy storage devices (lithium accumulators) are placed in parallel to power stations. The application of lithium accumulators over the line and their sizing was previously evaluated also in [10] which clearly discuss that an higher convenience is reached when energy storage systems are placed along the line with an optimal spacing of no more than $2 - 4\text{km}$. In the proposed scenario (8km between the two energy storage systems) authors suppose a lower line impedance whose additional costs should be compensated by the higher simplicity of the proposed layout;
- hybrid configuration: in this third configuration an on board energy storage system is added to the tram: the system is composed by a pack of super-capacitors corresponding to an equivalent capacity of 8.57 farad whose weight ($200\text{-}300\text{kg}$) is affordable respect to the dimension of the vehicle. Aim of the on board super-capacitors is only to smooth peak of current and consequently of voltage associated to regenerative braking. Some data concerning Super-Capacitors and Batteries are visible in tables 3 and 4.

In order to reduce as much as possible the wear of pads and discs, in all the three simulation scenarios is supposed to apply mainly electric braking (pneumatic braking activated only for speeds lower than 3km/h , so it's used like a parking brake). This hypothesis is not realistic but feasible mainly for the following reasons:

- performances in terms of maximum traction and braking efforts visible in figure 19 are sufficient;

<i>Main Features of Super-Capacitors:</i>	
<i>Capacity of a Single Cell</i>	3000[F]
<i>Number of Cells in Series</i>	350
<i>Nom. Voltage</i>	2.7[V]
<i>Max Voltage</i>	2.85[V]
<i>Min Voltage</i>	1.4[V]

Table 3. Main Features of On Board Energy Storage System (Super-Capacitors).

<i>Main Features of Stationary Accumulators:</i>	
<i>Nom. Cell Voltage</i>	3.7[V]
<i>Min. Cell Voltage</i>	3[V]
<i>Max. Cell Voltage</i>	4.2[V]
<i>Nom. Current</i>	100[A]
<i>Continuous Discharge Current</i>	800[A]
<i>Nom. Discharge Current</i>	1000[A]
<i>Peak Discharge Current</i>	1500[A]
<i>Energy Density</i>	145[Wh/kg]
<i>Number of cells in series</i>	205

Table 4. Main Features of Stationary Accumulators.

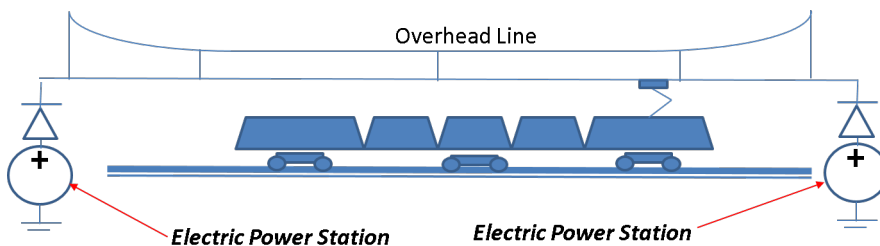

Figure 16. Scenario A: no energy storage installed on the overhead line.

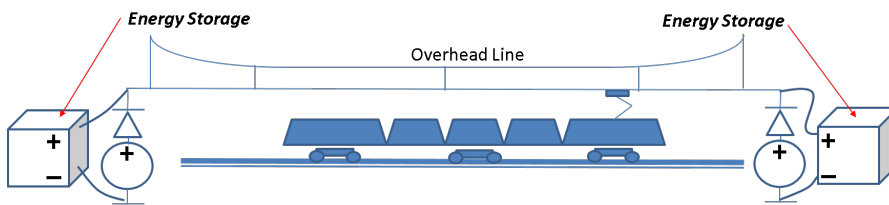

Figure 17. Scenario B: Stationary Accumulators along the line.

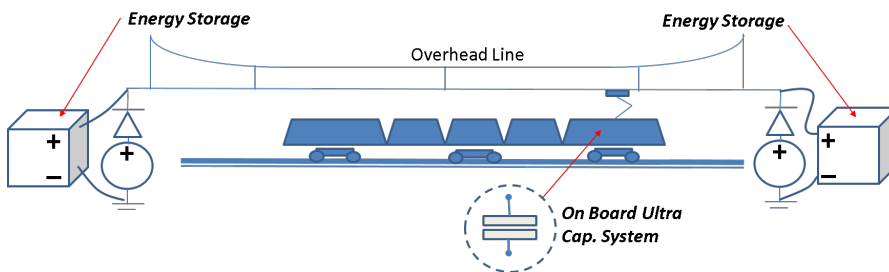

Figure 18. Scenario C: Hybrid system, on board super capacitors pack and Stationary Accumulators along the line.

- the vehicle wheelset ($B_0 - 2 - B_0$) assure that about the 70% of the vehicle weight is carried by motorized bogies;
- the required speed profiles involve maximum accelerations and decelerations of about $1 - 1.5ms^{-2}$ which correspond to wheel-rail adhesion coefficient of about 0.2 which is quite high but feasible considering the good performances of current traction and anti-skid systems;
- finally the simulation of the maximum regenerative braking should be considered more cautious in terms of electrical loads and potential voltage fluctuations to which is subjected the line.

However a blending strategy of the brake plant of the tram is simulated: pneumatic and electric braking are regulated to satisfy mainly two conditions: braking loads are distributed between bogies in order to be proportional to corresponding static normal loads (constant ratio between longitudinal and normal forces on wheel rail interface); on motorized bogies the applied electric braking effort is maximized respect to the total brake demand. Same simulations are repeated also considering the mixed application of both pneumatic and electric braking.

As a consequence the total number of evaluated test cases is equal to 6 (A,B,C Scenarios with maximum regenerative braking or blending).

Since during a run the state of charge of accumulators changes influencing simulation results, simulations are repeated several times, at each simulation run initialization values are modified according the result of the last one. In this way it's possible to verify the robustness of the obtained results respect to some variable parameters such as the initial state of charge of accumulators and to initialize the simulation in a more consistent way respect to its physical behavior.

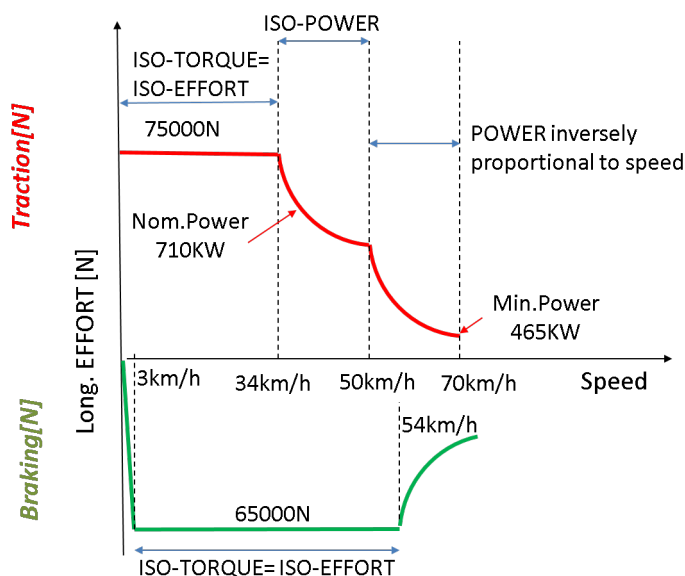

Figure 19. Traction and Braking Performances of the simulated tram (AnsaldoBreda Specifications [35] for a wheel diameter of 660mm and a nominal line voltage of 750V).

4.2. Approximated Calculation of Brake Pad Wear

Most of the works available in literature focused their attention to the increase of energy efficiency due to the application of regenerative braking. However it should be noticed that optimization in terms of both electric braking and of vehicle

speed profile, involve a considerable reduction of pads wear and consequently of the associated pollution as recorded also in [36]. As a consequence it should be interesting to calculate the wear rate of brake pads associated to a simulated mission profile. In the proposed tool, different models should be used for the calculation of brake pads, however after some years of research in this field, authors preferred to use the most simple in which is assumed a direct proportionality between the volume of removed material V_{wear} and the dissipated energy W_{wear} (6):

$$V_{wear} = k_{wear}W_{wear}, \quad (6)$$

where k_{wear} represent the proportionality factor which for commercial organic brake pads used in the railway sector has typical value of $0.2 - 0.3 \text{ cm}^3/MJ$.

At the end this simplified approach was preferred mainly for two reasons:

- the same approach is followed by tests on brake pads for their homologation on dynamometric test rig, as stated for example by fiche UIC 541-3. As a consequence this kind of information can be easily found or required to the maker of the pad;
- despite to the simplicity of the method extrapolation performed with this kind of approach are relatively accurate; as example, in figure 20 there is an indirect confirmation of the accuracy of the wear prediction of a test rig respect to the measurements on vehicles: the value of k_{wear} of two kind of pads (the first is an UIC approved pad, the second one was not approved) is compared with the corresponding wear measured in terms of pad thickness reduction respect to the traveled distance measured on coaches subjected to a constant monitoring; unfortunately the longitudinal dynamics of the experimental coach was not recorded during the monitoring, however it should be noticed that the wear of the second pad type is about three times higher respect to the approved one in both cases. As a consequence this is an indication that at least a good proportionality between results of test rigs and experiments on vehicles should be easily demonstrated.

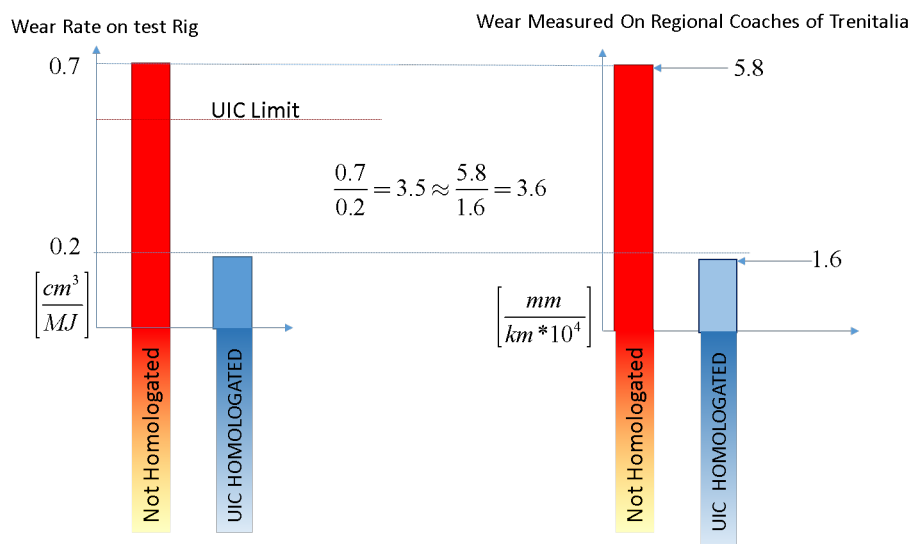

Figure 20. Comparison between specific wear rate measured on test rig for two different kind of pad and the corresponding mean wear measured over a monitored regional coach of Trenitalia (results of inspection activities).

4.3. Preliminary Simulation Results

In table 5 are compared mean energy consumptions corresponding to different simulation scenario. In order to have an idea of the improvement in terms of energy efficiency of the system it's also defined an efficiency index η_{id} defined as the ratio between an ideal value E_{id} and the consumed electrical energy E (7).

$$\eta_{id} = \frac{E_{id}}{E}. \quad (7)$$

In particular the ideal reference value E_{id} is calculated as the integral of the mechanical power W_{mec} transmitted by traction and braking systems to the train.

$$E_{id} = \int W_{mec} dt = \int T \dot{x} dt, \quad (8)$$

where T represents the total longitudinal effort transmitted by wheels to rails and \dot{x} the speed. As a consequence E_{id} represents the ideal amount of energy need to win the motion resistances of the train neglecting the main losses of the system:

- electrical efficiency of traction motors and power converters;
- losses of braking equipments (full regenerative braking on every axle of the train without losses);
- mechanical efficiency of gearboxes and transmission systems;
- electrical losses of the overhead line and electrical power stations;
- conversion and discharge losses of energy storage systems.

Looking at results of table 5, it's clearly noticeable that the introduction of energy storage systems along the line causes a sensible increase in terms of efficiency of the system since it allows the application of the regenerative braking. This solution is highly preferable respect to on board storage systems for the following reasons:

- no or reduced troubles concerning mass and encumbrances respect to an on board system; bigger and cheaper accumulators should be chosen. Avoiding an increase of the vehicle mass and a reduction of the useful payload;
- easier maintenance respect to an on board system including protection from environmental-weather conditions to which is subjected the system;
- the energy storage system should be customized respect to typical traffic and mission profile and design of the line. As example if the line has a known location to which is associated an higher power demand. This is particularly true for example for railway stations, or line intervals with high slopes-gradients.

On the other hand, stationary storage systems implies high peak of power and currents collected from the line as visible in figure 21 and in figure 22. For this reason in the third simulation scenario (C) an on board super-capacitor is added: the energy storage corresponding to the super-capacitors is quite low so weight and encumbrances are affordable for an existing vehicle. Also most of the energy is still stored by the stationary system. However the increase in terms of efficiency is appreciable since there is a reduction of current peaks and more generally of losses along the line. The effect of super-capacitors is higher during the regenerative braking phase and near to negligible during traction. This non linear behavior can be easily explained considering that in this simplified application super-capacitors are directly connected to the line; as a consequence stored energy depends from the

squared value of the line voltage. During regenerative braking line voltage is higher respect to the traction phase, typically 20% or even 30% higher.

Also as visible in figures 23 and 24, the application of super-capacitors on the vehicle clearly reduces line voltage fluctuations measured at the pantograph, thanks to the smoothing effects introduced by capacitors. This is particular important since relative fluctuations of line voltages over the 20% are generally not admissible both from a technical and normative point of view.

Looking at simulations in which regenerative braking is lower (blending with pneumatic braking is considered) voltages fluctuations associated to regenerative braking are lower but still appreciable.

A more flexible and efficient management of energy storage systems should be achieved by using a power converter (a chopper) to smartly couple the storage (battery accumulator or supercapacitor) to the load of the line. This is a solution that has been successfully investigated in previous works such as in [10].

Scenario A	Scenario B	Scenario C	Scenario A	Scenario B	Scenario C
Max Reg. Braking	Max Reg. Braking	Max Reg. Braking	Blending	Blending	Blending
100[MJ]	65.5[MJ]	58.8[MJ]	100[MJ]	76.5[MJ]	73.3[MJ]
$\eta_{id} = 17.7\%$	$\eta_{id} = 27\%$	$\eta_{id} = 30\%$	$\eta_{id} = 17.7\%$	$\eta_{id} = 23.2\%$	$\eta_{id} = 24\%$

Table 5. Energy Consumptions E [MJ].

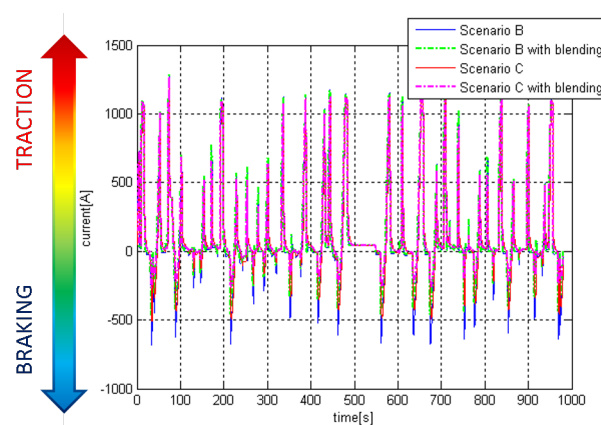

Figure 21. Behavior of Collected Current.

Finally in table 6 some result concerning the wear of pads in different scenarios (A, B with blending and B with a complete regenerative braking) are shown: in particular, it is considered the volume of consumed brake pad and consequently of powder produced in a single run and in a day of service (30 runs a day).

Considering the small dimension of generated particle the impact on the surrounding urban environment is not negligible.

It's interesting to notice that the volume of a single brake pad corresponds to about $300 - 350 \text{ cm}^3$ of material. As a consequence the pad wear corresponding to the simulation scenario A is quite important also in terms of maintenance costs. More generally the use of electric braking and the optimization of the speed profile of a tram have to consider also this aspect of the problem and not only the energetic efficiency.

In particular electric and regenerative braking should be maximized by reducing the deceleration of the tram in order to further minimize the quote of pneumatic

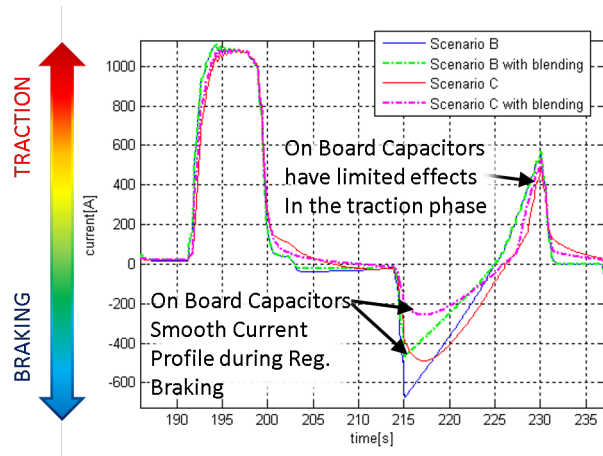

Figure 22. Collected Current, enlarged detail.

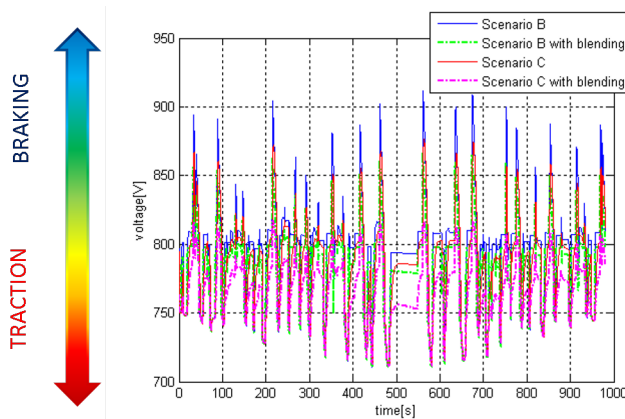

Figure 23. Voltages of the Line (measured at pantograph).

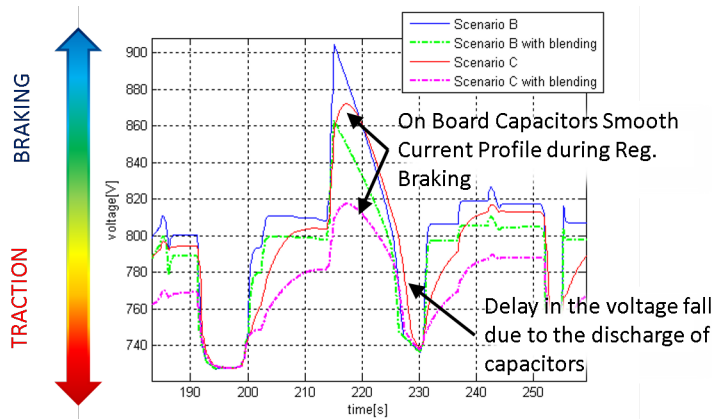

Figure 24. Voltages of the line (measured at pantograph), enlarged detail.

braking and to reduce the peak current and voltages to which is subjected the overhead line. This kind of optimization has to be carefully evaluated since a reduction of the braking deceleration should produce a significant degradation in terms of traveling time and consequently on timetables. This effect should be partially compensated by slightly increasing acceleration in the traction phase and maximum traveling speed, but also this kind of solution has to be carefully evaluated since it implies an increase in terms of required power during the acceleration of the train

and kinetic energy that have to be recovered or dissipated in the braking phase.

Scenario A	Scenario B with blending	Scenario B max reg.braking
18[cm^3]	6[cm^3]	0(<i>nowear</i>)
540[cm^3]	180[cm^3]	0(<i>nowear</i>)
daily wear	daily wear	
(30runs/day)	(30runs/day)	

Table 6. Wear of pads estimated for a single run and for a day ($K_{wear} = 0.3[cm^3/MJ]$).

5. Conclusion and Future Development

In this work has been presented a tool able to simulate and to optimize different aspects of traction and braking plant.

Respect to previous works in literature the tool is designed to integrate different modules able to simulate various physical phenomena (electric, mechanical, thermal, etc) which should define the optimization of both braking and traction system by considering complementary aspects of the problem. In particular the proposed tool has been used and preliminary validated on two benchmark case studies for which authors have data both from previous research activities and literature.

In particular in the second benchmark it's proposed the analysis of different energy storage systems applied to a known commercial tram, the AnsaldoBreda Sirio.

Results of the preliminary analisys performed considering a part of the Besancon tramway line indicates that an hybrid storage system composed by stationary accumulators along the line and a small on board super-capacitor should offer some interesting advantage in terms of system feasibility and performances.

it's foreseen in a short time a more accurate investigation including the introduction of a more sophisticated management of energy storage systems through power converters and the simulation of more complex scenario with multiple convoys traveling on the same line.

References

- [1] Baccari S., Cammeo G., Dufour C., Iannelli L. , Mungiguerra V., Porzio M., Reale G. and Vasca F., 2012, *Real-Time Hardware-in-the-Loop in Railway: Simulations for Testing Control Software of Electromechanical Train Components, Railway Safety, Reliability, and Security*, Technologies and Systems Engineering pp.221-248, IGI-GLOBAL, DOI: 10.4018/978-1-4666-1643-1.ch010.
- [2] Stephan A. 2008, *OpenPowerNetsimulation of railway power supply systems*, WIT Trans. Built Environ., vol. 103, pp.449 -459.
- [3] Malvezzi, M., Pugi, L., Conti, R., Toni, P., Tesi, S., Meli, E., Rindi, A. *A tool for prediction and optimization of railway traction systems with respect to an expected mission profile*.
- [4] Piechowiak T., *Pneumatic train brake simulation method*, Vehicle System Dynamics International Journal of Vehicle Mechanics and Mobility vol.47, No. 12,pp. 14731492.
- [5] Cantone L. 2011, *TrainDy: the new Union Internationale des Chemins de Fer software for freight train interoperability*, Proc. IMechE, Part F: J. Rail and Rapid Transit, 2011, 225 (F1), 57-70. DOI 10.1243/09544097JRRT347.
- [6] Pugi, L., Malvezzi, M., Papini, S., Vettori, G., *Design and preliminary validation of a tool for the simulation of train braking performance*, (2013) Journal of Modern Transportation, 21 (4), pp. 247-257.
- [7] Mirabadi A., Najafi M., *Proceedings of the Institution of Mechanical Engineers*, Part F: Journal of Rail and Rapid Transit, May 2011; vol. 225, 3: pp. 267-276.
- [8] De Martinis V., Gallo M. , *Models and Methods to Optimise Train Speed Profiles with and without Energy Recovery Systems: A Suburban Test Case*, *Procedia*, Social and Behavioral Sciences, Volume 87, 10 October 2013, Pages 222-233, ISSN 1877-0428, <http://dx.doi.org/10.1016/j.sbspro.2013.10.606>.
- [9] Barrero R. , Tackoen X , van Mierlo J. , *Stationary or onboard energy storage systems for energy consumption reduction in a metro network* *Proceedings of the Institution of Mechanical Engineers*, Part F: Journal of Rail and Rapid Transit, May 1, 2010; vol. 224, 3: pp. 207-225.

- [10] Ceraolo M., Lutzemberger G., *Stationary and on-board storage systems to enhance energy and cost efficiency of tramways*, Journal of Power Sources, Volume 264, 15 October 2014, Pages 128-139, ISSN 0378-7753, <http://dx.doi.org/10.1016/j.jpowsour.2014.04.070>.
- [11] Ehsani M., Gao Y., Emadi A., *Modern Electric, Hybrid Electric, and Fuel Cell Vehicles: Fundamentals, Theory, and Design*, Second Edition 2009 CRC PRESS.
- [12] Gonzalez-Gil A., Palacin R., Batty P., *Sustainable urban rail systems: Strategies and technologies for optimal management of regenerative braking energy*, Energy Conversion and Management, Volume 75, November 2013, Pages 374-388, ISSN 0196-8904, <http://dx.doi.org/10.1016/j.enconman.2013.06.039>.
- [13] Gonzalez-Gil A., Palacin R., Batty P., Powell J.P., *A systems approach to reduce urban rail energy consumption*, Energy Conversion and Management, Volume 80, April 2014, Pages 509-524, ISSN 0196-8904, <http://dx.doi.org/10.1016/j.enconman.2014.01.060>.
- [14] Barrero, R.; Van Mierlo, J.; Tackoen, X., *Energy savings in public transport*, Vehicular Technology Magazine, IEEE , vol.3, no.3, pp.26,36, Sept. 2008, doi: 10.1109/MVT.2008.927485.
- [15] Steiner, M.; Klohr, M.; Pagiela, S., *Energy storage system with ultracaps on board of railway vehicles*, Power Electronics and Applications, 2007 European Conference on , vol., no., pp.1,10, 2-5 Sept. 2007, doi: 10.1109/EPE.2007.4417400.
- [16] M. Thiounn-Guermeur, *Evaluation of the hybrid locomotive PLATHEEA Platform for Energy Efficiency and Environmentally Friendly Hybrid Trains*, Proceeding of WCRR 2011 (World Congress of Railway Research) Lille France.
- [17] Niu, Chunming and Sichel, Enid K. and Hoch, Robert and Moy, David and Tennent, Howard, *High power electrochemical capacitors based on carbon nanotube electrodes*, Applied Physics Letters, 70, 1480-1482 (1997), DOI:<http://dx.doi.org/10.1063/1.118568>
- [18] S Hillmansen and C Roberts, *Energy storage devices in hybrid railway vehicles: A kinematic analysis Proceedings of the Institution of Mechanical Engineers, Part F: Journal of Rail and Rapid Transit*, January 1, 2007; vol. 221, 1: pp. 135-143.
- [19] Ivaro J. Lpez-Lpez, Ramn R. Pecharromn, Antonio Fernndez-Cardador, A. Paloma Cucala, *Assessment of energy-saving techniques in direct-current-electrified mass transit systems*, Transportation Research Part C: Emerging Technologies, Volume 38, January 2014, Pages 85-100, ISSN 0968-090X, <http://dx.doi.org/10.1016/j.trc.2013.10.011>.
- [20] Iannuzzi D, Pagano E, Tricoli P. *The Use of Energy Storage Systems for Supporting the Voltage Needs of Urban and Suburban Railway Contact Lines Energies*. 2013; 6(4):1802-1820.
- [21] Sun Y., Cole C., Spiriyagin M., Godber T., Hames S, Rasul M., *Longitudinal heavy haul train simulations and energy analysis for typical Australian track routes*, Proceedings of the Institution of Mechanical Engineers, Part F: Journal of Rail and Rapid Transit 2014 228, DOI: 10.1177/0954409713476225.
- [22] *Mathworks*, Technical documentation of the Matlab Simulink program available at the site <http://www.mathworks.com/help/hdlcoder/ref/atomicssystem.html>
- [23] Byrd, R.H., J. C. Gilbert J.C., and Nocedal J., 2000, *A Trust Region Method Based on Interior Point Techniques for Nonlinear Programming*, Mathematical Programming, Vol 89, No. 1, pp. 149185.
- [24] Coleman, T.F. and Y. Li, 1996 *An Interior, Trust Region Approach for Nonlinear Minimization Subject to Bounds*, SIAM Journal on Optimization, Vol. 6, pp. 418445.
- [25] Huanhuan L., 2012, *Research of prognostics and health management for EMU*, IEEE Conference on Prognostics and System Health Management (PHM-2012 Beijing).
- [26] Pugi, L., Malvezzi, M., Tarasconi, A., Palazzolo, A., Cocci, G., Violani, M., *HIL simulation of WSP systems on MI-6 test rig*, (2006) Vehicle System Dynamics, 44 (SUPPL. 1), pp. 843-852.
- [27] *Brief history of the EMU V250 Train and of the Fyra project* freely available on web http://en.wikipedia.org/wiki/V250_train
- [28] Briginshaw D., *Fyra problems could be more political than technical* International Railway Journal (23 February 2013) freely available at the site <http://www.railjournal.com/index.php/blogs/david-briginshaw/fyra-problems-could-be-more-political-than-technical.html>
- [29] Pugi L., Malvezzi M., Allotta B., Banchi L., and Presciani P., 2004, *A parametric library for the simulation of a Union Internationale des Chemins de Fer (UIC) pneumatic braking system*, Proc. Inst. Mech. Eng. F, J. Rail Rapid Transit. 218 (2004), pp. 117132.
- [30] Krishan R., 2001, *Electric Motor Drives, Modelling Analysis and Control*, Prentice Hall, Upper Saddle River, NJ 07458 ISBN 013-091014-7.
- [31] Mantero, S., Monti, A.; Spreafico, C., 2000, *DC-bus voltage control for double star asynchronous fed drive under fault conditions*, IEEE 31st Annual Conference on Power Electronics Specialists.
- [32] S. Barsali, P. Bolognesi, M. Ceraolo, M. Funaioli and G. Lutzemberger, *Cyber-Physical Modelling of Railroad Vehicle Systems using Modelica Simulation Language*, Civil-Comp Press, 2014 Proceedings of the Second International Conference on Railway Technology: Research, Development and Maintenance, J. Pombo, (Editor), Civil-Comp Press, Stirlingshire, Scotland.
- [33] M. Ceraolo, M. Funaioli, G. Lutzemberger, M. Pasquali, D. Poli and L. Sani, *Electrical Storage for the Enhancement of Energy and Cost Efficiency of Urban Railroad Systems*, Proceedings of the Second International Conference on Railway Technology: Research, Development and Maintenance, J. Pombo, (Editor), Civil-Comp Press, Stirlingshire, Scotland.
- [34] Alberto Minoia didactical material freely available on web http://www-3.unipv.it/electric/cad/slide_T E/TE_Lezione4.pdf
- [35] AnsaldoBreda, *Technical Description of the Sirio Platform Vehicle*.
- [36] S Abbasi, L Olander, C Larsson, U Olofsson, A Jansson, and U Sellgren, *A field test study of airborne wear particles from a running regional train*, Proceedings of the Institution of Mechanical Engineers, Part F: Journal of Rail and Rapid Transit January 2012226 : 95 – 109, first published on August 23, 2011 doi : 10.1177/0954409711408774.